



ADDENDUM 3

August 4, 2021

ITB TDD 58-21

DFWB CONVENTION CENTER HVAC UPGRADES & RESTROOM RENOVATIONS

This addendum is to provide the answers to questions submitted by the vendors.

Questions and Responses:

Bid Question #1 - Missing panel schedule for new Panel MB.

Bid Question #1 Response – Refer to Addendum #2 and download updated plan set. See sheet E400 for Panel MB

Bid Question #2 - In the spec's section 011000- Summary page 1, para. 1.3 note 4 says to replace conduit/wire at cooling tower. I see nothing in the electrical drawings saying to replace conduit/wire. If we are to replace these items we need to know sizes and quantities for both. This work needs to be on the drawing or at least a written scope in an addendum.

Bid Question #2 Response – Revise 011000- Summary page 1, para. 1.3 note 4 to read, remove and replace cooling tower VFD's. See sheet E201 revision below:

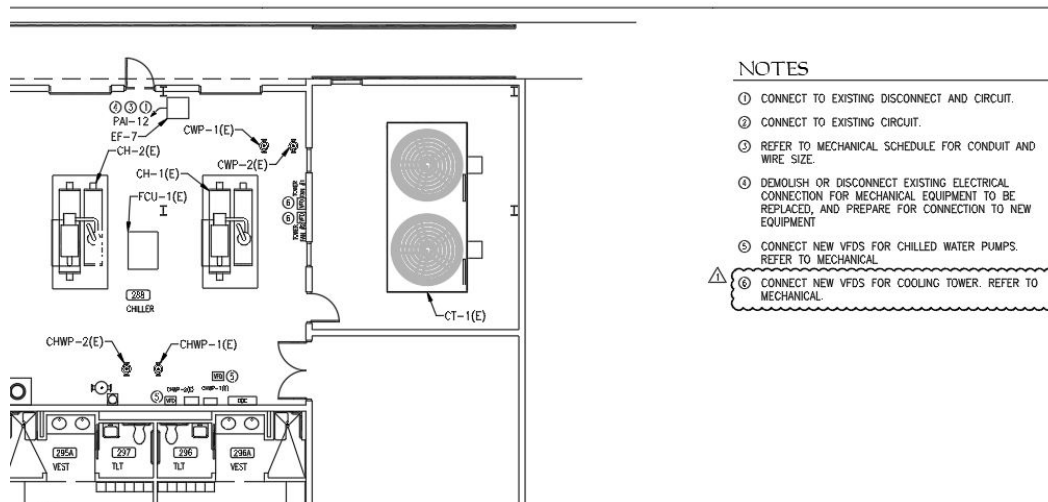

NOTES

- ① CONNECT TO EXISTING DISCONNECT AND CIRCUIT.
- ② CONNECT TO EXISTING CIRCUIT.
- ③ REFER TO MECHANICAL SCHEDULE FOR CONDUIT AND WIRE SIZE.
- ④ DEMOLISH OR DISCONNECT EXISTING ELECTRICAL CONNECTION FOR MECHANICAL EQUIPMENT TO BE REPLACED, AND PREPARE FOR CONNECTION TO NEW EQUIPMENT
- ⑤ CONNECT NEW VFDs FOR CHILLED WATER PUMPS. REFER TO MECHANICAL.
- ⑥ CONNECT NEW VFDs FOR COOLING TOWER. REFER TO MECHANICAL.

Bid Question #3 - The door schedule notes to attempt to salvage and refinish the existing doors and frames. Could an allowance for doors and frames be used to cover the cost for a new door in the event that the door/frame is unable to be salvaged? If the allowance is not used, said allowance will be issued back to the owner.

Bid Question #3 Response – Include a \$500 allowance per door to refinish existing doors and frames or replace.

Bid Question #4 – Could you provide a detail for the exterior hose bibb?

Bid Question #4 Response – Specification Section 221113, para 2.8, specifies a Wall Hydrant – Zurn Z1350 or equal by Acorn or Woodford. The plumbing fixture schedule on Sheet P001 references the Acorn 8160. The Zurn, Acorn, or equal Woodford is acceptable. See example below:

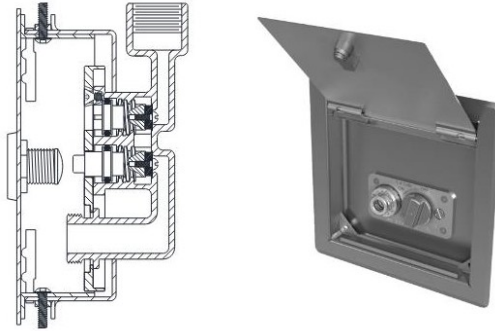

NOTE: The ITB Opening Date & Time remains unchanged.