



INVITATION TO BID (ITB) & RESPONDENT'S ACKNOWLEDGEMENT

ITB TITLE:

Destin-Fort Walton Beach Convention
Center Exterior Accessibility Project

ITB NUMBER:

ITB TDD 71-20

ISSUE DATE:

August 10, 2020

MANDATORY PRE-BID MEETING

August 19, 2020 1:00 P.M. cst

LAST DAY FOR QUESTIONS:

August 26, 2020 3:00 P.M. cst

ITB OPENING DATE & TIME:

September 09, 2020 3:15 P.M. cst

NOTE: BIDS RECEIVED AFTER THE BID OPENING DATE & TIME WILL NOT BE CONSIDERED.

Okaloosa County, Florida solicits your company to submit a bid on the above referenced goods or services. All terms, specifications and conditions set forth in this ITB are incorporated into your response. A bid will not be accepted unless all conditions have been met. All bids must have an authorized signature in the space provided below. All envelopes containing sealed bids must reference the "ITB Title", "ITB Number" and the "ITB Opening Date & Time". Okaloosa County is not responsible for lost or late delivery of bids by the U.S. Postal Service or other delivery services used by the respondent. Neither faxed nor electronically submitted bids will be accepted. Bids may not be withdrawn for a period of sixty (60) days after the bid opening unless otherwise specified.

RESPONDENT ACKNOWLEDGEMENT FORM BELOW MUST BE COMPLETED, SIGNED, AND RETURNED AS PART OF YOUR BID. BIDS WILL NOT BE ACCEPTED WITHOUT THIS FORM, SIGNED BY AN AUTHORIZED AGENT OF THE RESPONDENT.

COMPANY NAME _____

MAILING ADDRESS _____

CITY, STATE, ZIP _____

FEDERAL EMPLOYER'S IDENTIFICATION NUMBER (FEIN): _____

TELEPHONE NUMBER: _____ EXT: _____ FAX: _____

EMAIL: _____

I CERTIFY THAT THIS BID IS MADE WITHOUT PRIOR UNDERSTANDING, AGREEMENT, OR CONNECTION WITH ANY OTHER RESPONDENT SUBMITTING A BID FOR THE SAME MATERIALS, SUPPLIES, EQUIPMENT OR SERVICES, AND IS IN ALL RESPECTS FAIR AND WITHOUT COLLUSION OR FRAUD. I AGREE TO ABIDE BY ALL TERMS AND CONDITIONS OF THIS BID AND CERTIFY THAT I AM AUTHORIZED TO SIGN THIS BID FOR THE RESPONDENT.

AUTHORIZED SIGNATURE: _____ TYPED OR PRINTED NAME _____

TITLE: _____ DATE _____

NOTICE TO RESPONDENTS
ITB TDD 71-20

Notice is hereby given that the Board of County Commissioners of Okaloosa County, FL, will accept sealed bids until **3:15 pm CST September 9, 2020**, for the **Destin-Fort Walton Beach Convention Center Exterior Accessibility Project**.

Interested respondents shall provide one (1) original and two (2) copies (total of 3) of their Invitation to Bid (ITB) response with the respondent's areas of expertise identified. Submissions shall be portrait orientation, unbound, and 8 ½" x 11" where practical.

All originals must have original signatures in blue ink. Bid documents may be downloaded at the following sites:

<http://www.myokaloosa.com/purchasing/home>

<https://www.bidnetdirect.com/florida>

https://www.demandstar.com/supplier/bids/agency_inc/bid_list.asp?f=search&mi=2442519

A **mandatory Pre-Bid Conference** will be held at the Convention Center at 1250 Miracle Strip Pkwy SE, Fort Walton Beach, FL at **1:00 pm CST time on August 19, 2020**. Meet at the Main Entrance on the east side of the building and follow CDC guidelines, to include wearing a mask. We also request only two (2) persons from each entity attend.

At **3:15 pm CST September 9, 2020**, all bids will be opened and read aloud. All bids must be in sealed envelopes reflecting on the outside thereof the Respondent's name and "**Convention Center Exterior Accessibility**". The County will consider all bids properly submitted at its scheduled bid opening at **Okaloosa County Purchasing** at 5479A Old Bethel Rd., Crestview, FL. If delivering on the bid opening day, delivery must be in person at 5479A Old Bethel Rd., Crestview, FL.

The County reserves the right to award the bid to the lowest responsive respondent and to waive any irregularity or technicality in bids received. Okaloosa County shall be the sole judge of the bid and the resulting Agreement that is in its best interest and its decision shall be final.

Any Respondent failing to mark outside of the envelope as set forth herein may not be entitled to have their bid considered.

All bids should be addressed as follows:

Convention Center Exterior Accessibility ITB TDD 71-20

Okaloosa County Purchasing Department

5479A Old Bethel Rd.

Crestview FL 32536



Jeffrey Hyde
Purchasing Manager

08/05/2020

Date

OKALOOSA COUNTY
BOARD OF COUNTY COMMISSIONERS
ROBERT A. "TREY" GOODWIN, III, CHAIRMAN

GENERAL SERVICES INSURANCE REQUIREMENTS

REVISED: 01/2/2019

BONDING REQUIREMENTS

1. **Bid Bond:** A bid bond, in the form prescribed, Cashier's or Certified check, is required in an amount not less than five percent (5%) of the total contract amount. The Bid Bond must be attached to the bid.
2. **Performance and Payment Bond:** The successful Respondent shall furnish to the County, without extra compensation, and shall maintain in effect throughout the life of the Contract, and for the duration of the period described in the bond, acceptable Performance and Payment bonds in sums at least equal to the full amount of the Contract, conditioned to indemnify and save harmless the County from and against any loss, damage, or expense ensuing from failure on the part of the Contractor to faithfully and properly perform the Contract or to promptly pay all its subcontractors, suppliers, material, men or laborers for work completed on the Project. The required forms for the performance and payment bonds are included herein.

If within ten (10) calendar days after the acceptance of the bid, the successful Respondent shall refuse or neglect to execute the contract and to furnish the required performance and payment bonds properly signed by the Respondent and the surety or sureties satisfactorily to the County, the Respondent shall be deemed to be in default and the County will retain the bid surety as liquidated damages, but not as a penalty. The County reserves the option to accept the bid of any of the other Respondents within ten (10) calendar days from default, in which case such acceptance shall have the same effect on such Respondent as though they were the original, successful Respondent.

CONTRACTORS INSURANCE

1. The Contractor shall not commence any work in connection with this Agreement until he has obtained all required insurance and the certificate of insurance has been approved by the Okaloosa County Risk Manager or designee.
2. All insurance policies shall be with insurers authorized to do business in the State of Florida. Insuring company is required to have a minimum rating of A, Class X in the Best Key Rating Guide published by A.M. Best & Co. Inc.
3. All insurance shall include the interest of all entities named and their respective officials, employees & volunteers of each and all other interests as may be reasonably required by Okaloosa County. The coverage afforded the Additional Insured under this policy shall be primary insurance. If the Additional Insured have other insurance that is applicable to the loss, such other insurance shall be on an excess or contingent basis. The amount of the company's liability under this policy shall not be reduced by the existence of such other insurance.
4. Where applicable the County shall be shown as an Additional Insured with a waiver of Subrogation on the Certificate of Insurance.
5. The County shall retain the right to reject all insurance policies that do not meet the requirement of this Agreement. Further, the County reserves the right to change these insurance requirements with 60-day prior written notice to the Contractor.

6. The County reserves the right at any time to require the Contractor to provide copies (redacted if necessary) of any insurance policies to document the insurance coverage specified in this Agreement.
7. Any subsidiaries used shall also be required to obtain and maintain the same insurance requirements as are being required herein of the Contractor.
8. Any exclusions or provisions in the insurance maintained by the Contractor that excludes coverage for work contemplated in this agreement shall be deemed unacceptable and shall be considered breach of contract.

WORKERS' COMPENSATION INSURANCE

1. The Contractor shall secure and maintain during the life of this Agreement Workers' Compensation insurance for all of his employees employed for the project or any site connected with the work, including supervision, administration or management, of this project and in case any work is sublet, with the approval of the County, the Contractor shall require the Subcontractor similarly to provide Workers' Compensation insurance for all employees employed at the site of the project, and such evidence of insurance shall be furnished to the County not less than ten (10) days prior to the commencement of any and all sub-contractual Agreements which have been approved by the County.
2. Contractor must be in compliance with all applicable State and Federal workers' compensation laws, including the U.S. Longshore Harbor Workers' Act or Jones Act, if applicable.
3. No class of employee, including the Contractor himself, shall be excluded from the Workers' Compensation insurance coverage. The Workers' Compensation insurance shall also include Employer's Liability coverage.

BUSINESS AUTOMOBILE LIABILITY

Coverage must be afforded for all Owned, Hired, Scheduled, and Non-Owned vehicles for Bodily Injury and Property Damage in an amount not less than \$1,000,000 combined single limit each accident. If the contractor does not own vehicles, the contractor shall maintain coverage for Hired & Non-Owned Auto Liability, which may be satisfied by way of endorsement to the Commercial General Liability policy or separate Business Auto Policy. Contractor must maintain this insurance coverage throughout the life of this Agreement.

COMMERCIAL GENERAL LIABILITY INSURANCE

1. The Contractor shall carry Commercial General Liability insurance against all claims for Bodily Injury, Property Damage and Personal and Advertising Injury caused by the Contractor.
2. Commercial General Liability coverage shall include the following:
 - 1.) Premises & Operations Liability
 - 2.) Bodily Injury and Property Damage Liability
 - 3.) Independent Contractors Liability
 - 4.) Contractual Liability

5.) Products and Completed Operations Liability

3. Contractor shall agree to keep in continuous force Commercial General Liability coverage for the length of the contract.

INSURANCE LIMITS OF LIABILITY

The insurance required shall be written for not less than the following, or greater if required by law and shall include Employer's liability with limits as prescribed in this contract:

	<u>LIMIT</u>
1. Workers' Compensation	
1.) State	Statutory
2.) Employer's Liability	\$500,000 each accident
2. Business Automobile	\$1,000,000 each accident (A combined single limit)
3. Commercial General Liability	\$1,000,000 each occurrence for Bodily Injury & Property Damage \$1,000,000 each occurrence products and completed operations
4. Personal and Advertising Injury	\$1,000,000 each occurrence

NOTICE OF CLAIMS OR LITIGATION

The Contractor agrees to report any incident or claim that results from performance of this Agreement. The County representative shall receive written notice in the form of a detailed written report describing the incident or claim within ten (10) days of the Contractor's knowledge. In the event such incident or claim involves injury and/or property damage to a third party, verbal notification shall be given the same day the Contractor becomes aware of the incident or claim followed by a written detailed report within ten (10) days of verbal notification.

INDEMNIFICATION & HOLD HARMLESS

Contractor shall indemnify and hold harmless the County, its officers and employees from liabilities, damages, losses, and costs including but not limited to reasonable attorney fees, to the extent caused by the negligence, recklessness, or wrongful conduct of the Contractor and other persons employed or utilized by the Contractor in the performance of this contract.

CERTIFICATE OF INSURANCE

1. Certificates of insurance indicating the job site and evidencing all required coverage must be submitted not less than 10 days prior to the commencement of any of the work. The certificate holder(s) shall be as follows: Okaloosa County, 5479A Old Bethel Road, Crestview, Florida, 32536.
2. The contractor shall provide a Certificate of Insurance to the County with a thirty (30) day prior written notice of cancellation; ten (10 days' prior written notice if cancellation is for nonpayment of premium).
3. In the event that the insurer is unable to accommodate the cancellation notice requirement, it shall be

the responsibility of the contractor to provide the proper notice. Such notification shall be in writing by registered mail, return receipt requested, and addressed to the Okaloosa County Purchasing Department at 5479-A Old Bethel Road, Crestview, FL 32536.

4. In the event the contract term goes beyond the expiration date of the insurance policy, the contractor shall provide the County with an updated Certificate of insurance no later than ten (10) days prior to the expiration of the insurance currently in effect. The County reserves the right to suspend the contract until this requirement is met.
5. The certificate shall indicate if coverage is provided under a claims-made or occurrence form. If any coverage is provided on a claims-made form, the certificate will show a retroactive date, which should be the same date of the initial contract or prior.
6. All certificates shall be subject to Okaloosa County's approval of adequacy of protection.
7. All deductibles or SIRs, whether approved by Okaloosa County or not, shall be the Contractor's full responsibility.
8. In no way will the entities listed as Additional Insured be responsible for, pay for, be damaged by, or limited to coverage required by this schedule due to the existence of a deductible or SIR.

GENERAL TERMS

Any type of insurance or increase of limits of liability not described above which, the Contractor required for its own protection or on account of statute shall be its own responsibility and at its own expense.

Any exclusions or provisions in the insurance maintained by the contractor that excludes coverage for work contemplated in this contract shall be deemed unacceptable and shall be considered breach of contract.

The carrying of the insurance described shall in no way be interpreted as relieving the Contractor of any responsibility under this contract.

Should the Contractor engage a subcontractor or sub-subcontractor, the same conditions will apply under this Agreement to each subcontractor and sub-subcontractor.

The Contractor hereby waives all rights of subrogation against Okaloosa County and its employees under all the foregoing policies of insurance.

EXCESS/UMBRELLA INSURANCE

The Contractor shall have the right to meet the liability insurance requirements with the purchase of an EXCESS/UMBRELLA insurance policy. In all instances, the combination of primary and EXCESS/UMBRELLA liability coverage must equal or exceed the minimum liability insurance limits stated in this Agreement.

GENERAL BID CONDITIONS

1. **PRE-BID ACTIVITY** – **Except** as provided in this section, respondents are prohibited from contacting or lobbying the County, County Administrator, Commissioners, County staff, and Review Committee members, or any other person authorized on behalf of the County related or involved with the solicitation. All inquiries on the scope of work, specifications, additional requirements, attachments, terms and general conditions or instructions, or any issue must be directed in writing, by US mail or email to:

Okaloosa County Purchasing Department
5479A Old Bethel Road
Crestview, FL 32536
Email: aetheridge@myokaloosa.com
(850) 689-5960

All questions or inquiries must be received no later than the last day for questions (reference ITB & Respondent’s Acknowledgement form). Any addenda or other modification to the bid documents will be issued by the County five (5) days prior to the date and time of bid closing, as written addenda, and will be posted to and the Okaloosa County website at <http://www.co.okaloosa.fl.us/purchasing/current-solicitations> and the Bidnet website at <https://www.bidnetdirect.com/florida>.

Such written addenda or modification shall be part of the bid documents and shall be binding upon each respondent. Each respondent is required to acknowledge receipt of any and all addenda in writing and submit with their bid. No respondent may rely upon any verbal modification or interpretation.

2. **PREPARATION OF BID** – The bid form is included with the bid documents. Additional copies may be obtained from the County. The respondent shall submit bids in accordance with the public notice.

All blanks in the bid documents shall be completed by printing in ink or by typewriter in both words and numbers with the amounts extended, totaled and the bid signed. A bid price shall be indicated for each section, bid item, alternative, adjustment unit price item, and unit price item listed therein, or the words “No Bid”, “No Change”, or “Not Applicable” entered. No changes shall be made to the phraseology of the form or in the items mentioned therein. In case of any discrepancy between the written amount and the numerical figures, the written amount shall govern. Any bid which contains any omissions, erasures, alterations, additions, irregularities of any kind, or items not called for which shall in any manner fail to conform to the conditions of public notice inviting bids may be rejected.

A bid submitted by a partnership shall be executed in the partnership name and signed by a partner (whose title must appear under the signature). The official address of the partnership shall be shown below the signature.

A bid submitted by a limited liability company shall be executed in the name of the firm by a member and accompanied by evidence of authority to sign. The state of formation of the firm and the official address of the firm must be shown below the signature.

A bid submitted by an individual shall show the respondent’s name and official address.

A bid submitted by a joint venture shall be executed by each joint venture in the manner indicated on the bid form. The official address of the joint venture must be shown below the signature.

It is preferred that all signatures be in blue ink with the names type or printed below the signature. Okaloosa County does not accept electronic signatures.

The bid shall contain an acknowledgement of receipt of all Addenda, the numbers of which shall be filled in on the form. The address and telephone # for communications regarding the bid shall be shown.

If the respondent is an out-of-state corporation, the bid shall contain evidence of respondent's authority and qualification to do business as an out-of-state corporation in the State of Florida. A state contractor license # for the State of Florida shall also be included on the bid form. Respondent shall be licensed in accordance with the requirements of Chapter 489, Florida Statutes.

3. **INTEGRITY OF BID DOCUMENTS – Respondents** shall use the original Bid documents provided by the Purchasing Department and enter information only in the spaces where a response is requested. Respondents may use an attachment as an addendum to the Bid documents if sufficient space is not available. Any modifications or alterations to the original bid documents by the respondent, whether intentional or otherwise, will constitute grounds for rejection of a bid. Any such modification or alteration that a respondent wish to propose must be clearly stated in the respondent's response in the form of an addendum to the original bid documents.
4. **SUBMITTAL OF BID** – A bid shall be submitted no later than the date and time prescribed and at the place indicated in the advertisement or invitation to bid and shall be enclosed in an opaque sealed envelope plainly marked with the project title (and, if applicable, the designated portion of the project for which the bid is submitted), the name and address of the respondent, and shall be accompanied by the bid security and other required documents. It is the respondent's responsibility to assure that its bid is delivered at the proper time and place. Offers by telegram, facsimile, or telephone will **NOT** be accepted.

Note: Crestview is not a next day delivery site for overnight carriers.

5. **MODIFICATION & WITHDRAWAL OF BID** – A bid may be modified or withdrawn by an appropriate document duly executed in the manner that a bid must be executed and delivered to the place where bids are to be submitted prior to the date and time for the opening of bids.

If within 24 hours after bids are opened any respondent files a duly signed written notice with the County and promptly thereafter demonstrates to the reasonable satisfaction of the County that there was a material substantial mistake in the preparation of its bid, that respondent may withdraw its bid, and the bid security may be returned. Thereafter, if the work is rebid, that respondent will be disqualified from 1) further bidding on the work, and 2) doing any work on the contract, either as a subcontractor or in any other capacity.

6. **BIDS TO REMAIN SUBJECT TO ACCEPTANCE** – All bids will remain subject to acceptance or rejection for sixty (60) calendar days after the day of the bid opening, but the County may, in its sole discretion, release any bid and return the bid security prior to the end of this period.
7. **IDENTICAL TIE BIDS** – In cases of identical procurement responses, the award shall be determined either by lot or on the basis of factors deemed to serve the best interest of the County. In the case of the latter, there must be adequate documentation to support such a decision.

8. **CONDITIONAL & INCOMPLETE BIDS** – Okaloosa County specifically reserves the right to reject any conditional bid and bids which make it impossible to determine the true amount of the bid.
9. **PRICING** – The bid price shall include all equipment, labor, materials, freight, taxes etc. Okaloosa County reserves the right to select that bid most responsive to our needs.
10. **ADDITION/DELETION OF ITEM** – The County reserves the right to add or delete any item from this bid or resulting contract when deemed to be in the County’s best interest.
11. **SPECIFICATION EXCEPTIONS** – Specifications are based on the most current literature available. Respondent shall clearly list any change in the manufacturer’s specifications which conflict with the bid specifications. Respondent must also explain any deviation from the bid specification in writing, as a foot note on the applicable bid page and enclose a copy of the manufacturer’s specifications data detailing the changed item(s) with their bid. Failure of the respondent to comply with these provisions will result in respondents being held responsible for all costs required to bring the equipment in compliance with bid specifications.
12. **APPLICABLE LAWS & REGULATIONS** – All applicable Federal and State laws, County and municipal ordinances, orders, rules and regulations of all authorities having jurisdiction over the project shall apply to the bid throughout, and they will be deemed to be included in the contract the same as though they were written in full therein.
13. **DISQUALIFICATION OF RESPONDENTS** – Any of the following reasons may be considered as sufficient for the disqualification of a respondent and the rejection of its bid:
 - a. Submission of more than one proposal for the same work from an individual, firm or corporation under the same or different name.
 - b. Evidence that the respondent has a financial interest in the firm of another respondent for the same work.
 - c. Evidence of collusion among respondents. Participants in such collusion will receive no recognition as respondents for any future work of the County until such participant has been reinstated as a qualified respondent.
 - d. Uncompleted work which in the judgment of the County might hinder or prevent the prompt completion of additional work if awarded.
 - e. Failure to pay or satisfactorily settle all bills due for labor and material on former contracts in force at the time of advertisement of proposals.
 - f. Default under previous contract.
 - g. Listing of the respondent by any Local, State or Federal Government on its barred/suspended vendor list.

14. AWARD OF BID

- A. **Okaloosa County Review** - Okaloosa County designated Staff will review all bids and will participate in the Recommendation to Award.

- B. The County will award the bid to the responsive and responsible vendor(s) with the lowest responsive bid(s), and the County reserves the right to award the bid to the respondent submitting a responsive bid with a resulting negotiated agreement which is most advantageous and in the best interest of the County, and to reject any and all bids or to waive any irregularity or technicality in bids received. Okaloosa County shall be the sole judge of the bid and the resulting negotiated agreement that is in its best interest and its decision shall be final.
- C. Okaloosa County reserves the right to waive any informalities or reject any and all bids, in whole or part, to utilize any applicable state contracts in lieu of or in addition to this bid and to accept the bid that in its judgment will best serve the interest of the County.
- D. Okaloosa County specifically reserves the right to reject any conditional bids and will normally reject those which made it impossible to determine the true amount of the bid. Each item must be bid separately and no attempt is to be made to tie any item or items to any other item or items.

15. PAYMENTS – The respondent shall be paid upon submission of invoices and approval of acceptance by Okaloosa County Board of County Commissioners, Finance Office, 302 N. Wilson St., #203, Crestview FL 32536, for the prices stipulated herein for articles delivered and accepted. Invoices must show Contract #.

16. DISCRIMINATION – An entity or affiliate who has been placed on the discriminatory vendor list may not submit a bid on a contract to provide goods or services to a public entity, may not submit a bid on a contract with a public entity for the construction or repair of a public building or public work, may not submit bids on leases of real property to a public entity, may not award or perform work as a contractor, supplier, subcontractor, or consultant under contract with any public entity, and may not transact business with any public entity.

17. PUBLIC ENTITY CRIME INFORMATION – Pursuant to Florida Statute 287.133, a respondent may not be awarded or perform work as a contractor, supplier, subcontractor, or consultant under a contract with any public entity; and may not transact business with any public entity in excess of the threshold amount provided in s. [287.017](#) for CATEGORY TWO for a period of 36 months following the date of being placed on the convicted vendor list.

18. CONFLICT OF INTEREST – The award hereunder is subject to the provisions of Chapter 112, Florida Statutes. All respondents must disclose with their bids the name of any officer, director, or agent who is also a public officer or an employee of the Okaloosa Board of County Commissioners, or any of its agencies. Furthermore, all respondents must disclose the name of any County officer or employee who owns, directly or indirectly, an interest of five percent (5%) or more in the firm or any of its branches.

Note: For respondent's convenience, this certification form is enclosed and is made a part of the bid package.

19. REORGANIZATION OR BANKRUPTCY PROCEEDINGS – Bids will not be considered from respondents who are currently involved in official financial reorganization or bankruptcy proceedings.

20. INVESTIGATION OF RESPONDENT – The County may make such investigations, as it deems necessary to determine the stability of the respondent to perform the work and that there is no conflict of

interest as it relates to the project. The respondent shall furnish to the Owner any additional information and financial data for this purpose as the County may request.

- 21. CONE OF SILENCE CLAUSE** – The Okaloosa County Board of County Commissioners has established a solicitation silence policy (**Cone of Silence Clause**) that prohibits oral and written communication regarding all formal solicitations for goods and services (formal bids, Request for Proposals, Requests for Qualifications) issued by the Board through the County Purchasing Department. The period commences from the date of advertisement until award of contract.

All communications shall be directed to the Purchasing Department – see attached form.

Note: For respondent’s convenience, this certification form is enclosed and is made a part of the bid package.

- 22. REVIEW OF PROCUREMENT DOCUMENTS** – Per Florida Statute 119.071 (2) 2 sealed bids, proposals, or replies received by the County pursuant to a competitive solicitation are exempt from public disclosure until such time as the County provides notice of an intended decision or until 30 days after opening the bids, proposals, or final replies, whichever is earlier.

- 23. COMPLIANCE WITH FLORIDA STATUTE 119.0701** – The Respondent shall comply with all the provisions of section 119.0701, Florida Statutes relating to the public records which requires, among other things, that the Respondent: (a) Keep and maintain public records; (b) Provide the public with access to public records on the same terms and conditions that the public agency would provide the records; (c) ensure that public records that are exempt or confidential and exempt from public records disclosure requirements are not disclosed except as authorized by law; and (d) Meet all requirements for retaining public records and transfer, at no cost, to the public agency all public records in possession of the respondent upon termination of the contract.

- 24. PROTECTION OF RESIDENT WORKERS** – The Okaloosa County Board of County Commissioners actively supports the Immigration and Nationality Act (INA) which includes provisions addressing employment eligibility, employment verifications, and nondiscrimination. Under the INA, employers may hire only persons who may legally work in the United States (i.e., citizens and nationals of the U.S.) and aliens authorized to work in the U.S. The employer must verify the identity and employment eligibility of anyone to be hired, which includes completing the Employment Eligibility Verifications. The respondent shall establish appropriate procedures and controls so no services or products under the Contract Documents will be performed or manufactured by any worker who is not legally eligible to perform such services or employment. Okaloosa County reserves the right to request documentation showing compliance with the requirements.

Respondents doing construction business with Okaloosa County are required to use the Federal Government Department of Homeland Security’s website and use the E-Verify Employment Eligibility Verifications System to confirm eligibility of all employees to work in the United States.

- 25. SUSPENSION OR TERMINATION FOR CONVENIENCE** – The County may, at any time, without cause, order Respondent in writing to suspend, delay or interrupt the work in whole or in part for such period of time as the County may determine, or to terminate all or a portion of the Contract for the County’s convenience. Upon such termination, the Contract Price earned to the date of termination shall be paid to Respondent, but Respondent waives any claim for damages, including loss of profits arising out of or related to the early termination. Those Contract provisions which by their nature survive final acceptance shall remain in full force and effect. If the County orders a suspension,

the Contract price and Contract time may be adjusted for increases in the cost and time caused by suspension, delay or interruption. No adjustment shall be made to the extent that performance is, was or would have been so suspended, delayed or interrupted by reason for which Respondent is responsible; or that an equitable adjustment is made or denied under another provision of this Contract.

- 26. FAILURE OF PERFORMANCE/DELIVERY** – In case of default by the respondent, the County after due notice (oral or written) may procure the necessary supplies or services from other sources and hold the respondent responsible for difference in cost incurred. Continuous instances of default shall result in cancellation of the award and removal of the respondent from the bid list for duration of one (1) year, at the option of the County.
- 27. AUDIT** – If requested, respondent shall permit the County or an authorized, independent audit agency to inspect all data and records of respondent relating to its performance and its subcontracts under this bid from the date of the award through three (3) years after the expiration of contract.
- 28. EQUAL EMPLOYMENT OPPORTUNITY; NON DISCRIMINATION** – Respondent will not discriminate against any employee or an applicant for employment because of race, color, religion, gender, sexual orientation, national origin, age, familial status or handicap.
- 29. NON-COLLUSION** – Respondent certifies that it has entered into no agreement to commit a fraudulent, deceitful, unlawful or wrongful act, or any act which may result in an unfair advantage over other respondents. See Florida Statute 838.22.
- 30. UNAUTHORIZED ALIENS/PATRIOT'S ACT** – The knowing employment by respondent or its subcontractors of any alien not authorized to work by the immigration laws is prohibited and shall be a default of the contract. In the event that the respondent is notified or becomes aware of such default, the respondent shall take steps as are necessary to terminate said employment with 24 hours of notification or actual knowledge that an alien is being employed. Respondent's failure to take such steps as are necessary to terminate the employment of any said alien within 24 hours of notification or actual knowledge that an alien is being employed shall be grounds for immediate termination of the contract. Respondent shall take all commercially reasonable precautions to ensure that it and its subcontractors do not employ persons who are not authorized to work by the immigration laws.
- 31. CERTIFICATE OF GOOD STANDING FOR STATE OF FLORIDA** – Florida Statute 607.1501 requires that all vendors who wish to do business in the State of Florida be licensed to do business through the Department of State of Florida and be in good standing with the State of Florida. As such, to do business with Okaloosa County a vendor must provide a Certificate of Good Standing with their bid/proposal package to the County. For more information on doing business in the State of Florida, please refer to the Florida Department of State. The website to register is <https://dos.myflorida.com/sunbiz>.

32. The following documents shall be submitted with the bid packet. Failure to provide required forms may result in contractor disqualification.

- A. Drug-Free Workplace Certification Form
- B. Conflict of Interest
- C. Federal E-Verify
- D. Cone of Silence Form
- E. Recycled Content Form
- F. Indemnification and Hold Harmless
- G. Prohibition to Lobbying
- H. Company Data
- I. System of Awards Management
- J. Addendum Acknowledgement
- K. Bid Sheet
- L. Anti-Collusion Statement
- M. Governmental Debarment & Suspension
- N. Vendors on Scrutinized Companies List
- O. Certificate of Good Standing for State of Florida-see number 31
- P. Bid Set
- Q. Construction Drawings

DRUG-FREE WORKPLACE CERTIFICATION

THE BELOW SIGNED RESPONDENT CERTIFIES that it has implemented a drug-free workplace program. In order to have a drug-free workplace program, a business shall:

1. Publish a statement notifying employees that the unlawful manufacture, distribution, dispensing, possession, or use of a controlled substance is prohibited in the workplace and specifying the actions that will be taken against employees for violations of such prohibition.
2. Inform employees about the dangers of drug abuse in the workplace, the business's policy of maintaining a drug-free workplace, any available drug counseling, rehabilitation and employee assistance programs, and the penalties that may be imposed upon employees for drug abuse violations.
3. Give each employee engaged in providing the commodities or contractual services that are under quote a copy of the statement specified in subsection 1.
4. In the statement specified in subsection 1, notify the employees that, as a condition of working on the commodities or contractual services that are under quote, the employee will abide by the terms of the statement and will notify the employer of any conviction of, or plea of guilty or nolo contendere to, any violation of Chapter 893, Florida Statutes, or of any controlled substance law of the United States or any state, for a violation occurring in the workplace no later than five (5) days after such conviction.
5. Impose a sanction on, or require the satisfactory participation in, drug abuse assistance or rehabilitation program if such is available in employee's community, by any employee who is convicted.
6. Make a good faith effort to continue to maintain a drug-free workplace through implementation of this section.

As the person authorized to sign this statement, I certify that this firm complies fully with the above requirements.

DATE: _____

SIGNATURE: _____

COMPANY: _____

NAME: _____
(Typed or Printed)

ADDRESS: _____

TITLE: _____

E-MAIL: _____

PHONE NO.: _____

CONFLICT OF INTEREST DISCLOSURE FORM

For purposes of determining any possible conflict of interest, all respondents, must disclose if any Okaloosa Board of County Commissioner, employee(s), elected officials(s), or if any of its agencies is also an owner, corporate officer, agency, employee, etc., of their business.

Indicate either “yes” (a county employee, elected official, or agency is also associated with your business), or “no”. If yes, give person(s) name(s) and position(s) with your business.

YES _____

NO _____

NAME(S)

POSITION(S)

FIRM NAME: _____

BY (PRINTED): _____

BY (SIGNATURE): _____

TITLE: _____

ADDRESS: _____

PHONE NO. _____

E-MAIL _____

DATE _____

FEDERAL E-VERIFY COMPLIANCE CERTIFICATION

In accordance with Okaloosa County Policy and Executive Order Number 11-116 from the office of the Governor of the State of Florida, Respondent hereby certifies that the U.S. Department of Homeland Security's E-Verify system will be used to verify the employment eligibility of all new employees hired by the respondent during the contract term, and shall expressly require any subcontractors performing work or providing services pursuant to the contact to likewise utilize the U.S. Department of Homeland Securities E-Verify system to verify the employment eligibility of all new employees hired by the subcontractor during the contract term; and shall provide documentation such verification to the COUNTY upon request.

As the person authorized to sign this statement, I certify that this company complies/will comply fully with the above requirements.

DATE: _____

SIGNATURE: _____

COMPANY: _____

NAME: _____

ADDRESS: _____

TITLE: _____

E-MAIL: _____

PHONE NO.: _____

CONE OF SILENCE CLAUSE

The Board of County Commissioners have established a solicitation silence policy (**Cone of Silence Clause**) that prohibits oral and written communication regarding all formal solicitations for goods and services (formal bids, Request for Proposals, Requests for Qualifications, Invitation to Quote, Invitation to Negotiate) issued by the Board through the County Purchasing Department.

The period commences upon receipt of the procurement proposal, by the County, and terminates upon Board approval to award a contract or reject all bids/responses.

When the solicitation silence period is in effect, no oral or written communication is allowed regarding the solicitation between prospective respondents and members of the Board of County Commissioners, the County Administrator, county employees or members of the Board Approved Review Committee. All questions or requests for information regarding the solicitation **MUST** be directed to the designated Purchasing Representative listed in the solicitation.

Any information thought to affect the committee or staff recommendation submitted after bids are due, should be directed to the Purchasing Director or an appointed representative. It shall be the Purchasing Director decision whether to consider this information in the decision process.

Any violation of this policy shall be grounds to disqualify the respondent from consideration during the selection process.

All respondents must agree to comply with this policy by signing the following statement and including it with their submittal.

I _____ representing _____
Signature **Company Name**

On this _____ day of _____ 20__ hereby agree to abide by the County's "**Cone of Silence Clause**" and understand violation of this policy shall result in disqualification of my proposal/submittal.

RECYCLED CONTENT FORM

RECYCLED CONTENT INFORMATION

1. Is the material in the above: Virgin _____ or Recycled _____ (Check the applicable blank). If recycled, what percentage _____%.

Product Description: _____

2. Is your product packaged and/or shipped in material containing recycled content?

Yes _____ No _____

Specify: _____

3. Is your product recyclable after it has reached its intended end use?

Yes _____ No _____

Specify: _____

The above is not applicable if there is only a personal service involved with no product involvement.

Name of Respondent: _____

E-Mail: _____

INDEMNIFICATION AND HOLD HARMLESS

Respondent shall indemnify and hold harmless the County, its officers and employees from liabilities, damages, losses, and costs including but not limited to attorney fees, to the extent caused by the negligence, recklessness, or intentional wrongful conduct of the Respondent and other persons employed or utilized by the Respondent in the performance of this Agreement.

Respondent's Company Name

Authorized Signature – Manual

Physical Address

Authorized Signature – Typed

Mailing Address

Title

Phone Number

FAX Number

Cellular Number

After-Hours Number(s)

Date

Email Address

LOBBYING - 31 U.S.C. 1352, 49 CFR Part 19, 49 CFR Part 20

APPENDIX A, 49 CFR PART 20--CERTIFICATION REGARDING LOBBYING

Certification for Contracts, Grants, Loans, and Cooperative Agreements

(To be submitted with each bid or offer exceeding \$100,000)

The undersigned [Contractor] certifies, to the best of his or her knowledge and belief, that:

1. No Federal appropriated funds have been paid or will be paid, by or on behalf of the undersigned, to any person for influencing or attempting to influence an officer or employee of an agency, a Member of Congress, an officer or employee of Congress, or an employee of a Member of Congress in connection with the awarding of any Federal contract, the making of any Federal grant, the making of any Federal loan, the entering into of any cooperative agreement, and the extension, continuation, renewal, amendment, or modification of any Federal contract, grant, loan, or cooperative agreement.
2. If any funds other than Federal appropriated funds have been paid or will be paid to any person for making lobbying contacts to an officer or employee of any agency, a Member of Congress, an officer or employee of Congress, or an employee of a Member of Congress in connection with this Federal contract, grant, loan, or cooperative agreement, the undersigned shall complete and submit Standard Form--LLL, "Disclosure Form to Report Lobbying," in accordance with its instructions [as amended by "Government wide Guidance for New Restrictions on Lobbying," 61 Fed. Reg. 1413 (1/19/96). Note: Language in paragraph (2) herein has been modified in accordance with Section 10 of the Lobbying Disclosure Act of 1995 (P.L. 104-65, to be codified at 2 U.S.C. 1601, *et seq.*)]
3. The undersigned shall require that the language of this certification be included in the award documents for all subawards at all tiers (including subcontracts, subgrants, and contracts under grants, loans, and cooperative agreements) and that all subrecipients shall certify and disclose accordingly.

This certification is a material representation of fact upon which reliance was placed when this transaction was made or entered into. Submission of this certification is a prerequisite for making or entering into this transaction imposed by 31, U.S.C. § 1352 (as amended by the Lobbying Disclosure Act of 1995). Any person who fails to file the required certification shall be subject to a civil penalty of not less than \$10,000 and not more than \$100,000 for each such failure.

[Note: Pursuant to 31 U.S.C. § 1352(c)(1) -(2)(A), any person who makes a prohibited expenditure or fails to file or amend a required certification or disclosure form shall be subject to a civil penalty of not less than \$10,000 and not more than \$100,000 for each such expenditure or failure.]

The Contractor, _____, certifies or affirms the truthfulness and accuracy of each statement of its certification and disclosure, if any. In addition, the Contractor understands and agrees that the provisions of 31 U.S.C. A 3801, *et seq.*, apply to this certification and disclosure, if any.

_____ Signature of Contractor's Authorized Official

_____ Name and Title of Contractor's Authorized Official

_____ Date

COMPANY DATA

Respondent's Company Name: _____

Physical Address & Phone #: _____

Contact Person (Typed-Printed): _____

Phone #: _____

Cell #: _____

Federal ID or SS #: _____

DUNNS #: _____

Respondent's License #: _____

Fax #: _____

Emergency #'s After Hours,
Weekends & Holidays: _____

Email Address: _____

SYSTEM FOR AWARD MANAGEMENT (OCT 2016)

(a) Definitions. As used in this provision.

“Electronic Funds Transfer (EFT) indicator” means a four-character suffix to the unique entity identifier. The suffix is assigned at the discretion of the commercial, nonprofit, or Government entity to establish additional System for Award Management records for identifying alternative EFT accounts (see [subpart 32.11](#)) for the same entity.

“Registered in the System for Award Management (SAM) database” means that.

(1) The Offeror has entered all mandatory information, including the unique entity identifier and the EFT indicator, if applicable, the Commercial and Government Entity (CAGE) code, as well as data required by the Federal Funding Accountability and Transparency Act of 2006 (see [subpart 4.14](#)) into the SAM database;

(2) The offeror has completed the Core, Assertions, and Representations and Certifications, and Points of Contact sections of the registration in the SAM database;

(3) The Government has validated all mandatory data fields, to include validation of the Taxpayer Identification Number (TIN) with the Internal Revenue Service (IRS). The offeror will be required to provide consent for TIN validation to the Government as a part of the SAM registration process; and

(4) The Government has marked the record “Active”.

“Unique entity identifier” means a number or other identifier used to identify a specific commercial, nonprofit, or Government entity. See www.sam.gov for the designated entity for establishing unique entity identifiers.

(b)(1) By submission of an offer, the offeror acknowledges the requirement that a prospective awardee shall be registered in the SAM database prior to award, during performance, and through final payment of any contract, basic agreement, basic ordering agreement, or blanket purchasing agreement resulting from this solicitation.

(2) The Offeror shall enter, in the block with its name and address on the cover page of its offer, the annotation “Unique Entity Identifier” followed by the unique entity identifier that identifies the Offeror’s name and address exactly as stated in the offer. The Offeror also shall enter its EFT indicator, if applicable. The unique entity identifier will be used by the Contracting Officer to verify that the Offeror is registered in the SAM database.

(c) If the Offeror does not have a unique entity identifier, it should contact the entity designated at www.sam.gov for establishment of the unique entity identifier directly to obtain one. The Offeror should be prepared to provide the following information:

- (1) Company legal business name.
- (2) Tradestyle, doing business, or other name by which your entity is commonly recognized.
- (3) Company Physical Street Address, City, State, and Zip Code.
- (4) Company Mailing Address, City, State and Zip Code (if separate from physical).
- (5) Company telephone number.
- (6) Date the company was started.
- (7) Number of employees at your location.
- (8) Chief executive officer/key manager.
- (9) Line of business (industry).
- (10) Company Headquarters name and address (reporting relationship within your entity).

(d) If the Offeror does not become registered in the SAM database in the time prescribed by the Contracting Officer, the Contracting Officer will proceed to award to the next otherwise successful registered Offeror.

(e) Processing time, which normally takes 48 hours, should be taken into consideration when registering. Offerors who are not registered should consider applying for registration immediately upon receipt of this solicitation.

(f) Offerors may obtain information on registration at <https://www.acquisition.gov> .

Offerors SAM information:

Entity Name: _____

Entity Address: _____

Duns Number: _____

CAGE Code: _____

ADDENDUM ACKNOWLEDGEMENT

ITB TDD 71-20

Acknowledgment is hereby made of the following addenda (identified by number) received since issuance of solicitation:

<u>ADDENDUM NO.</u>	<u>DATE</u>

NOTE: Prior to submitting the response to this solicitation, it is the responsibility of the respondent to confirm if any addenda have been issued. If such addenda have been issued, acknowledge receipt by noting number(s) and date(s) above.

BID RESPONSE

**ITB TDD 71-20
DESTIN FORT WALTON BEACH CONVENTION CENTER
EXTERIOR ACCESSIBILITY**

SUBMITTED BY _____

BID ITEM:	BID AMOUNT:
Bid Amount – Phase 1	\$ _____
Bid Amount – Phase 2	\$ _____
Bid Amount – Phase 3	\$ _____
Bid Amount – Phase 4	\$ _____
Bid Amount – Phase 5	\$ _____
Bid Amount – Phase 6	\$ _____
TOTAL BASE BID AMOUNT	\$ _____
Bid Amount – Phase 7 (Optional)	\$ _____

The total number of days to substantial completion for the project is anticipated to be two-hundred ten days (210) calendar days with the final completion date at two-hundred forty days (240).

Estimated Notice to Proceed Date will be October 2020.

**In the event that Substantial Completion is not achieved by the Substantial Completion Date, except as a result only from delays for which the County is chargeable under the Contract Documents, Bidder agrees that Owner shall have the right to deduct from any sums due to Bidder hereunder the sum of four hundred dollars (\$400.00) for each day that Substantial Completion is delayed.*

ANTI-COLLUSION STATEMENT: The below signed bidder has not divulged to, discussed or compared his bid with other bidders and has not **colluded with any other bidder or parties to bid whatever. Note: No premiums, rebates, or gratuities permitted either with, prior to, or after any** delivery of materials. Any such violation will result in the cancellation and/or return of material (as applicable) and the removal from bid list(s).

Bidder's Company Name

Authorized Signature – Manual

Address

Authorized Signature – Typed

Address

Title

Phone #

Fax #

Federal ID # or SS #

**SWORN STATEMENT UNDER SECTION 287.133 (3) (a),
FLORIDA STATUTES, ON PUBLIC ENTITY CRIMES**

THIS FORM MUST BE SIGNED IN THE PRESENCE OF A NOTARY PUBLIC OR OTHER OFFICIAL AUTHORIZED TO ADMINISTER OATHS.

1. This sworn statement is submitted for _____
2. This sworn statement is submitted by _____
whose business address is: _____ and
(if applicable) its Federal Employer Identification Number (FEIN) is _____.
(If entity has no FEIN, include the Social Security Number of the individual signing this sworn statement _____).
3. My name is _____ and my relationship to the entity named above is _____.
4. I understand that a “public entity crime” as defined in Section 287.133(1)(g), Florida Statutes, means a violation of any state or federal law by a person with respect to and directly related to the transaction of business with any public entity or with an agency or political subdivision of any other state or of the United States, including, but not limited to, any bid or contract for goods or services to be provided to any public entity or an agency or political subdivision of any other state or of the United States and involving antitrust, fraud, theft, bribery, collusion, racketeering, conspiracy, or material misrepresentation.
5. I understand that “convicted” or “conviction” as defined in Section 287.133 (1) (b), Florida Statutes, means a finding of guilt or a conviction of a public entity crime, with or without adjudication of guilt, in any federal or state trial court of record, relating to charges brought by indictment or information after July 1, 1989, as a result of a jury verdict, non-jury trial, or entry of a plea of guilty or nolo contendere.
6. I understand that an “affiliate” as defined in Section 287.133(1) (a), Florida Statutes, means: (1) A predecessor or successor of a person convicted of a public entity crime; or (2) An entity under the control of any natural person who is active in the management of the entity and who has been convicted of a public entity crime. The term “affiliate” includes those officers, directors, executives, partners, shareholders, employees, members, and agents who are active in the management of an affiliate. The ownership by one person of shares constituting a controlling interest in another person, or a pooling of equipment or income among persons when not for fair market value under an arm’s length agreement, shall be a prima facie case that one person controls another person. A person who knowingly enters into a joint venture with a person who has been convicted of a public entity crime in Florida during the preceding 36 months shall be considered an affiliate.
7. I understand that a “person” as defined in Section 287.133(1) (e), Florida Statutes, means any natural person or entity organized under the laws of any state or of the United States with the legal power to enter into a binding contract and which bids or applies to bid on contracts for the provision of goods or services let by a public entity, or which otherwise transacts or applies to transact business with a

public entity. The term "person" includes those officers, directors, executives, partners, shareholders, employees, members, and agents who are active in management of an entity.

8. Based on information and belief, that statement which I have marked below is true in relation to the entity submitting this sworn statement. [Please indicate which statement applies.]

_____ Neither the entity submitting this sworn statement, nor one or more of the officers, directors, executives, partners, shareholders, employees, members, or agents who are active in the management of the entity, nor any affiliate of the entity, has been charged with and convicted of public entity crime subsequent to July 1, 1989.

_____ There has been a proceeding concerning the conviction before a hearing officer of the State of Florida, Division of Administrative Hearings. The final order entered by the hearing officer did not place the person or affiliate on the convicted vendor list. [Please attach a copy of the Final Order.]

_____ The person or affiliate was placed on the convicted vendor list. There has been a subsequent proceeding before a hearing officer of the State of Florida, Division of Administrative Hearings. The final order entered by the hearing officer determined that it was in the public interest to remove the person or affiliate from the convicted vendor list. [Please attach a copy of the Final Order.]

_____ The person or affiliate has not been placed on the convicted vendor list. [Please describe any action taken by or pending with the Department of General Services.]

Date: _____ Signature: _____

STATE OF: _____

COUNTY OF: _____

PERSONALLY APPEARED BEFORE ME, the undersigned authority, who after first being sworn by me, affixed his/her signature in the space provided above on this _____ day of _____, in the year _____.

My commission expires: _____

Notary Public

Print, Type, or Stamp of Notary Public

Personally known to me, or Produced Identification:

Type of ID

Government Debarment & Suspension

Instructions

1. By signing and submitting this form, the prospective lower tier participant is providing the certification set out in accordance with these instructions.
2. The certification in this clause is a material representation of fact upon which reliance was placed when this transaction was entered into. If it is later determined that the prospective lower tier participant knowingly rendered an erroneous certification, in addition to other remedies available to the Federal Government, the department or agency with which this transaction originated may pursue available remedies, including suspension or debarment.
3. The prospective lower tier participant shall provide immediate written notice to the person(s) to which this proposal is submitted if at any time the prospective lower tier participant learns that its certification was erroneous when submitted or has become erroneous by reason of changed circumstances.
4. The terms "covered transaction," "debarred," "suspended," "ineligible," "lower tier covered transaction," "participant," "person," "primary covered transaction," "principal," "proposal," and "voluntarily excluded," as used in this clause, have the meanings set out in the Definitions and Coverage sections of the rules implementing Executive Orders 12549, at Subpart C of OMB 2 C.F.R. Part 180 and 3000.332. You may contact the department or agency to which this proposal is being submitted for assistance in obtaining a copy of those regulations.
5. The prospective lower tier participant agrees by submitting this form that, should the proposed covered transaction be entered into, it shall not knowingly enter into any lower tier covered transaction with a person who is debarred, suspended, declared ineligible, or voluntarily excluded from participation in this covered transaction, unless authorized by the department or agency with which this transaction originated.
6. The prospective lower tier participant further agrees by submitting this form that it will include this clause titled "Certification Regarding Debarment, Suspension, Ineligibility and Voluntary Exclusion - Lower Tier Covered Transactions," without modification, in all lower tier covered transactions and in all solicitations for lower tier covered transactions.
7. A participant in a covered transaction may rely upon a certification of a prospective participant in a lower tier covered transaction that is not debarred, suspended, ineligible, or voluntarily excluded from the covered transaction, unless it knows that the certification is erroneous. A participant may decide the method and frequency by which it determines the eligibility of its principals. Each participant may, but is not required to, check the System for Award Management (SAM) database.
8. Nothing contained in the foregoing shall be construed to require establishment of a system of records in order to render in good faith the certification required by this clause. The knowledge and information of a participant is not required to exceed that which is normally possessed by a prudent person in the ordinary course of business dealings.
9. Except for transactions authorized under paragraph (5) of these instructions, if a participant in a covered transaction knowingly enters into a lower tier covered transaction with a person who is suspended, debarred, ineligible, or voluntarily excluded from participation in this transaction, in addition to other remedies available to the Federal Government, the department or agency with which this transaction originated may pursue available remedies, including suspension and/or debarment.

**Certification Regarding Debarment, Suspension,
Ineligibility and Voluntary Exclusion
Lower Tier Covered Transactions**

The following statement is made in accordance with the Privacy Act of 1974 (5 U.S.C. § 552(a), as amended). This certification is required by the regulations implementing Executive Orders 12549, Debarment and Suspension, and OMB 2 C.F.R. Part 180, Participants' responsibilities. The regulations were amended and published on August 31, 2005, in 70 Fed. Reg. 51865-51880.

[READ INSTRUCTIONS ON PREVIOUS PAGE BEFORE COMPLETING CERTIFICATION]

1. The prospective lower tier participant certifies, by submission of this proposal, that neither it nor its principals is presently debarred, suspended, proposed for debarment, declared ineligible, or voluntarily excluded from participation in this transaction by any Federal or State department or agency;

2. Where the prospective lower tier participant is unable to certify to any of the statements in this certification, such prospective participant shall attach an explanation to this proposal

Printed Name and Title of Authorized Representative _____

Signature

Date

VENDORS ON SCRUTINIZED COMPANIES LISTS

By executing this Certificate _____, the bid proposer, certifies that it is not: (1) listed on the Scrutinized Companies that Boycott Israel List, created pursuant to section 215.4725, Florida Statutes, (2) engaged in a boycott of Israel, (3) listed on the Scrutinized Companies with Activities in Sudan List or the Scrutinized Companies with Activities in the Iran Petroleum Energy Sector List, created pursuant to section 215.473, Florida Statutes, or (4) engaged in business operations in Cuba or Syria. Pursuant to section 287.135(5), Florida Statutes, the County may disqualify the bid proper immediately or immediately terminate any agreement entered into for cause if the bid proposer is found to have submitted a false certification as to the above or if the Contractor is placed on the Scrutinized Companies that Boycott Israel List, is engaged in a boycott of Israel, has been placed on the Scrutinized Companies with Activities in Sudan List or the Scrutinized Companies with Activities in the Iran Petroleum Energy Sector List, or has been engaged in business operations in Cuba or Syria, during the term of the Agreement. If the County determines that the bid proposer has submitted a false certification, the County will provide written notice to the bid proposer. Unless the bid proposer demonstrates in writing, within 90 calendar days of receipt of the notice, that the County's determination of false certification was made in error, the County shall bring a civil action against the bid proposer. If the County's determination is upheld, a civil penalty shall apply, and the bid proposer will be ineligible to bid on any Agreement with a Florida agency or local governmental entity for three years after the date of County's determination of false certification by bid proposer.

As the person authorized to sign this statement, I certify that this firm complies fully with the above requirements.

DATE: _____

SIGNATURE: _____

COMPANY: _____

NAME: _____

(Typed or Printed)

ADDRESS: _____

TITLE: _____

E-MAIL: _____

PHONE NO: _____

Exhibit “B”

Standard Contract Clauses

Title VI Clauses for Compliance with Nondiscrimination Requirements

Compliance with Nondiscrimination Requirements

During the performance of this contract, the contractor, for itself, its assignees, and successors in interest (hereinafter referred to as the “contractor”) agrees as follows:

1. **Compliance with Regulations:** The contractor (hereinafter includes consultants) will comply with the Title VI List of Pertinent Nondiscrimination Acts And Authorities, as they may be amended from time to time, which are herein incorporated by reference and made a part of this contract.
2. **Non-discrimination:** The contractor, with regard to the work performed by it during the contract, will not discriminate on the grounds of race, color, or national origin in the selection and retention of subcontractors, including procurements of materials and leases of equipment. The contractor will not participate directly or indirectly in the discrimination prohibited by the Nondiscrimination Acts and Authorities, including employment practices when the contract covers any activity, project, or program set forth in Appendix B of 49 CFR part 21.
3. **Solicitations for Subcontracts, Including Procurements of Materials and Equipment:** In all solicitations, either by competitive bidding, or negotiation made by the contractor for work to be performed under a subcontract, including procurements of materials, or leases of equipment, each potential subcontractor or supplier will be notified by the contractor of the contractor’s obligations under this contract and the Nondiscrimination Acts And Authorities on the grounds of race, color, or national origin.
4. **Information and Reports:** The contractor will provide all information and reports required by the Acts, the Regulations, and directives issued pursuant thereto and will permit access to its books, records, accounts, other sources of information, and its facilities as may be determined by the sponsor or the Federal Aviation Administration to be pertinent to ascertain compliance with such Nondiscrimination Acts And Authorities and instructions. Where any information required of a contractor is in the exclusive possession of another who fails or refuses to furnish the information, the contractor will so certify to the sponsor or the Federal Aviation Administration, as appropriate, and will set forth what efforts it has made to obtain the information.
5. **Sanctions for Noncompliance:** In the event of a contractor’s noncompliance with the Non-discrimination provisions of this contract, the sponsor will impose such contract sanctions as it or the Federal Aviation Administration may determine to be appropriate, including, but not limited to:
 - a. Withholding payments to the contractor under the contract until the contractor complies; and/or
 - b. Cancelling, terminating, or suspending a contract, in whole or in part.
6. **Incorporation of Provisions:** The contractor will include the provisions of paragraphs one through six in every subcontract, including procurements of materials and leases of equipment, unless exempt

by the Acts, the Regulations and directives issued pursuant thereto. The contractor will take action with respect to any subcontract or procurement as the sponsor or the Federal Aviation Administration may direct as a means of enforcing such provisions including sanctions for noncompliance. Provided, that if the contractor becomes involved in, or is threatened with litigation by a subcontractor, or supplier because of such direction, the contractor may request the sponsor to enter into any litigation to protect the interests of the sponsor. In addition, the contractor may request the United States to enter into the litigation to protect the interests of the United States.

Title VI List of Pertinent Nondiscrimination Acts and Authorities

Title VI List of Pertinent Nondiscrimination Acts and Authorities

During the performance of this contract, the contractor, for itself, its assignees, and successors in interest (hereinafter referred to as the “contractor”) agrees to comply with the following non-discrimination statutes and authorities; including but not limited to:

- Title VI of the Civil Rights Act of 1964 (42 U.S.C. § 2000d *et seq.*, 78 stat. 252), (prohibits discrimination on the basis of race, color, national origin);
- 49 CFR part 21 (Non-discrimination In Federally-Assisted Programs of The Department of Transportation—Effectuation of Title VI of The Civil Rights Act of 1964);
- The Uniform Relocation Assistance and Real Property Acquisition Policies Act of 1970, (42 U.S.C. § 4601), (prohibits unfair treatment of persons displaced or whose property has been acquired because of Federal or Federal-aid programs and projects);
- Section 504 of the Rehabilitation Act of 1973, (29 U.S.C. § 794 *et seq.*), as amended, (prohibits discrimination on the basis of disability); and 49 CFR part 27;
- The Age Discrimination Act of 1975, as amended, (42 U.S.C. § 6101 *et seq.*), (prohibits discrimination on the basis of age);
- Airport and Airway Improvement Act of 1982, (49 USC § 471, Section 47123), as amended, (prohibits discrimination based on race, creed, color, national origin, or sex);
- The Civil Rights Restoration Act of 1987, (PL 100-209), (Broadened the scope, coverage and applicability of Title VI of the Civil Rights Act of 1964, The Age Discrimination Act of 1975 and Section 504 of the Rehabilitation Act of 1973, by expanding the definition of the terms “programs or activities” to include all of the programs or activities of the Federal-aid recipients, sub-recipients and contractors, whether such programs or activities are Federally funded or not);
- Titles II and III of the Americans with Disabilities Act of 1990, which prohibit discrimination on the basis of disability in the operation of public entities, public and private transportation systems, places of public accommodation, and certain testing entities (42 U.S.C. §§ 12131 – 12189) as implemented by Department of Transportation regulations at 49 CFR parts 37 and 38;
- The Federal Aviation Administration’s Non-discrimination statute (49 U.S.C. § 47123) (prohibits discrimination on the basis of race, color, national origin, and sex);
- Executive Order 12898, Federal Actions to Address Environmental Justice in Minority Populations and Low-Income Populations, which ensures non-discrimination against minority populations by

discouraging programs, policies, and activities with disproportionately high and adverse human health or environmental effects on minority and low-income populations;

- Executive Order 13166, Improving Access to Services for Persons with Limited English Proficiency, and resulting agency guidance, national origin discrimination includes discrimination because of limited English proficiency (LEP). To ensure compliance with Title VI, you must take reasonable steps to ensure that LEP persons have meaningful access to your programs (70 Fed. Reg. at 74087 to 74100);
- Title IX of the Education Amendments of 1972, as amended, which prohibits you from discriminating because of sex in education programs or activities (20 U.S.C. 1681 et seq).

FEDERAL FAIR LABOR STANDARDS ACT (FEDERAL MINIMUM WAGE)

All contracts and subcontracts that result from this solicitation incorporate by reference the provisions of 29 CFR part 201, the Federal Fair Labor Standards Act (FLSA), with the same force and effect as if given in full text. The FLSA sets minimum wage, overtime pay, recordkeeping, and child labor standards for full and part time workers.

The [*contractor* | *consultant*] has full responsibility to monitor compliance to the referenced statute or regulation. The [*contractor* | *consultant*] must address any claims or disputes that arise from this requirement directly with the U.S. Department of Labor – Wage and Hour Division

OCCUPATIONAL SAFETY AND HEALTH ACT OF 1970

All contracts and subcontracts that result from this solicitation incorporate by reference the requirements of 29 CFR Part 1910 with the same force and effect as if given in full text. Contractor must provide a work environment that is free from recognized hazards that may cause death or serious physical harm to the employee. The Contractor retains full responsibility to monitor its compliance and their subcontractor's compliance with the applicable requirements of the Occupational Safety and Health Act of 1970 (20 CFR Part 1910). Contractor must address any claims or disputes that pertain to a referenced requirement directly with the U.S. Department of Labor – Occupational Safety and Health Administration.

E-VERIFY

Enrollment and verification requirements.

- (1) If the Contractor is not enrolled as a Federal Contractor in E-Verify at time of contract award, the Contractor shall-
 - a. Enroll. Enroll as a Federal Contractor in the E-Verify Program within thirty (30) calendar days of contract award;
 - b. Verify all new employees. Within ninety (90) calendar days of enrollment in the E-Verify program, begin to use E-Verify to initiate verification of employment eligibility of all new hires of the Contractor, who are working in the United States, whether or not assigned to the contract, within three (3) business days after the date of hire (but see paragraph (b)(3) of this section); and,

- c. Verify employees assigned to the contract. For each employee assigned to the contract, initiate verification within ninety (90) calendar days after date of enrollment or within thirty (30) calendar days of the employee's assignment to the contract, whichever date is later (but see paragraph (b)(4) of this section.)
- (2) If the Contractor is enrolled as a Federal Contractor in E-Verify at time of contract award, the Contractor shall use E-Verify to initiate verification of employment eligibility of
 - a. All new employees.
 - i. Enrolled ninety (90) calendar days or more. The Contractor shall initiate verification of all new hires of the Contractor, who are working in the United States, whether or not assigned to the contract, within three (3) business days after the date of hire (but see paragraph (b)(3) of this section); or
 - b. Enrolled less than ninety (90) calendar days. Within ninety (90) calendar days after enrollment as a Federal Contractor in E-Verify, the Contractor shall initiate verification of all new hires of the contractor, who are working in the United States, whether or not assigned to the contract, within three (3) business days after the date of hire (but see paragraph (b)(3) of this section); or
 - ii. Employees assigned to the contract. For each employee assigned to the contract, the Contractor shall initiate verification within ninety (90) calendar days after date of contract award or within thirty (30) days after assignment to the contract, whichever date is later (but see paragraph (b)(4) of this section.)
- (3) If the Contractor is an institution of higher education (as defined at 20 U.S.C. 1001(a)); a State of local government or the government of a Federally recognized Indian tribe, or a surety performing under a takeover agreement entered into with a Federal agency pursuant to a performance bond, the Contractor may choose to verify only employees assigned to the contract, whether existing employees or new hires. The Contractor shall follow the applicable verification requirements of (b)(1) or (b)(2), respectively, except that any requirement for verification of new employees applies only to new employees assigned to the contract.
- (4) Option to verify employment eligibility of all employees. The Contractor may elect to verify all existing employees hired after November 6, 1986 (after November 27, 2009, in the Commonwealth of the Northern Mariana Islands), rather than just those employees assigned to the contract. The Contractor shall initiate verification for each existing employee working in the United States who was hired after November 6, 1986 (after November 27, 2009, in the Commonwealth of the Northern Mariana Islands), within one hundred eighty (180) calendar days of-
 - i. Enrollment in the E-Verify program; or
 - ii. Notification to E-Verify Operations of the Contractor's decision to exercise this option, using the contract information provided in the E-Verify program Memorandum of Understanding (MOU)

(5) The Contractor shall comply, for the period of performance of this contract, with the requirements of the E-Verify program MOU.

i. The Department of Homeland Security (DHS) or the Social Security Administration (SSA) may terminate the Contractor's MOU and deny access to the E-Verify system in accordance with the terms of the MOU. In such case, the Contractor, will be referred to a suspension or debarment official.

ii. During the period between termination of the MOU and a decision by the suspension or debarment official whether to suspend or debar, the contractor is excused from its obligations under paragraph (b) of this clause. If the suspension or debarment official determines not to suspend or debar the Contractor, then the Contractor must reenroll in E-Verify.

iii. Web site. Information on registration for and use of the E-Verify program can be obtained via the Internet at the Department of Homeland Security Web site: <http://www.dhs.gov/E-Verify>.

Individuals previously verified. The Contractor is not required by this clause to perform additional employment verification using E-Verify for any employee-

- (a) Whose employment eligibility was previously verified by the Contractor through the E-Verify program;
- (b) Who has been granted and holds an active U.S. Government security clearance for access to confidential, secret, or top secret information in accordance with the National Industrial Security Program Operating Manual; or
- (c) Who has undergone a completed background investigation and been issued credentials pursuant to Homeland Security Presidential Directive (HSPD)-12. Policy for a Common Identification Standard for Federal Employees and Contractors.

Subcontracts. The Contractor shall include the requirements of this clause, including this paragraph € (appropriately modified for identification of the parties in each subcontract that-

- (1) Is for-(i) Commercial and noncommercial services (except for commercial services that are part of the purchase of a COTS item (or an item that would be a COTS item, but for minor modifications), performed by the COTS provider, and are normally provided for that COTS item); or
 - (ii) Construction;
- (2) Has a value of more than \$3,500; and
- (3) Includes work performed in the United States.

BID SET

**DESTIN FORT WALTON BEACH
CONVENTION CENTER**

**EXTERIOR ACCESSIBILITY
FORT WALTON BEACH, FLORIDA**

PROJECT MANUAL

JUNE 2020



Project Consultant



**Okaloosa County TDC – Destin Fort Walton Beach Convention Center
Exterior Accessibility**

TABLE OF CONTENTS

DIVISION 01 – GENERAL REQUIREMENTS

- 01 00 00 Summary
- 01 25 00 Substitution Procedures
- 01 26 00 Contract Modification Procedures
- 01 31 00 Project Management and Coordination
- 01 40 00 Quality Requirements
- 01 50 00 Temporary Facilities and Controls
- 01 60 00 Product Requirements
- 01 73 00 Execution

DIVISION 02 – EXISTING CONDITIONS

- 02 41 19 Selective Demolition

DIVISION 05 – METALS

- 05 52 13 Pipe and Tube Railings

DIVISION 07 – THERMAL AND MOISTURE PROTECTION

- 07 21 00 Thermal Insulation
- 07 90 00 Joint Sealants

DIVISION 08 – OPENINGS

- 08 11 13 Hollow Metal Doors and Frames
- 08 31 13 Access Doors and Frames
- 08 42 13 Aluminum – Framed Entrances
- 08 42 29 Sliding Automatic Entrances
- 08 71 00 Door Hardware

DIVISION 09 – FINISHES

- 09 22 16 Non-Structural Metal Framing
- 09 24 00 Cement Plastering
- 09 29 00 Gypsum Board
- 09 68 13 Tile Carpeting
- 09 91 13 Exterior Painting
- 09 91 23 Interior Painting

DIVISION 13 – SPECIAL CONSTRUCTION

- 13 11 54 Fountain Tile

**Okaloosa County TDC – Destin Fort Walton Beach Convention Center
Exterior Accessibility**

DIVISION 32 – EXTERIOR IMPROVEMENTS

31 14 00 Unit Paving

**Okaloosa County TDC – Destin Fort Walton Beach Convention Center
Exterior Accessibility**

SECTION 011000 - SUMMARY

PART 1 - GENERAL

1.1 SUMMARY

A. Section Includes:

1. Project information.
2. Work covered by Contract Documents.
3. Phased construction.
4. Access to site.
5. Coordination with occupants.
6. Work restrictions.

B. Related Requirements:

1. Section 015000 "Temporary Facilities and Controls" for limitations and procedures governing temporary use of Owner's facilities.

1.2 PROJECT INFORMATION

A. Project Identification: Destin Fort Walton Beach Convention Center – Exterior Accessibility

1. Project Location: Destin Fort Walton Beach Convention Center – 1250 Miracle Strip Parkway SE, Fort Walton Beach, Florida 32548.

B. Owner: Okaloosa County.

1. Owner's Representative: Jeffrey A. Hyde, Purchasing Manager, Okaloosa County Purchasing.

C. Architect: DAG Architects Inc. Destin, Florida.

1.3 WORK COVERED BY CONTRACT DOCUMENTS

A. The Work of Project is defined by the Contract Documents and consists of the following:

1. Phase 1
 - a. North Stair sidewalk replacement
 - b. Add ADA curb cuts on north and south sides of garage access drive
 - c. Demolish existing planter island at south end of center island
 - d. Demolish existing concrete patio at the northeast grass area and replace with new enlarged concrete patio
 - e. Extend south end of center island
 - f. Add curb ramps at south and north ends of center island
 - g. Relocate ADA parking spaces, rework parking lot planters and sidewalks
 - h. Replace lighted bollards with plastic coated bollards at traffic locations
 - i. Remove and replace existing site lighting with solar powered lights.
 - j. Asphalt pavement, pavers, sidewalks, curbing, and drainage inlets as required

**Okaloosa County TDC – Destin Fort Walton Beach Convention Center
Exterior Accessibility**

2. Phase 2
 - a. Demolish existing center island stairs
 - b. Add new stairs, retaining walls and railings
 - c. Coordination requirements for renovated fountain water and power.
3. Phase 3
 - a. Demolish existing main entry stairs
 - b. Add new stairs and railings
 - c. Retaining walls for patio on north and south sides of new main entry stairs
4. Phase 4
 - a. Demolish portion of existing screen wall at intermediate landing at ADA ramp at north side of main entrance
 - b. Add new parking garage cast-in-place concrete stair, landings, railings and lights.
5. Phase 5
 - a. Demolish existing main entry doorway system and ticket booth walls and doors.
 - b. Add new main entry vestibule with new sliding doors, storefront doors and access control
 - c. Remodel ticket booth and office to coordinate with new vestibule.
6. Phase 6
 - a. Remove existing landscaping and irrigation from east and south sides of building and center island.
 - b. Add new landscaping and irrigation for the east, north and south sides of building and center island
 - c. Relocate existing palm trees to east side of parking lot
7. Phase 7
 - a. Demolish and remove fountain tiling, finishes, equipment, lighting, piping, fixtures and selected concrete and rebar.
 - b. Add new fountain concrete, tiling, finishes, equipment, lighting, piping and fixtures.

B. Type of Contract:

1. Project will be constructed under a single prime contract.

1.4 PHASED CONSTRUCTION

- A. The Work shall be conducted in 7 phases, with each phase substantially complete as indicated.
- B. Before commencing Work of each phase, submit an updated copy of Contractor's construction schedule showing the sequence, commencement and completion dates for all phases of the Work.

1.5 ACCESS TO SITE

- A. General: Contractor shall have limited use of Project site for construction operations as indicated on Drawings by the Contract limits and as indicated by requirements of this Section.
- B. Use of Site: Limit use of Project site to Work in areas indicated. Do not disturb portions of Project site beyond areas in which the Work is indicated.

**Okaloosa County TDC – Destin Fort Walton Beach Convention Center
Exterior Accessibility**

1. Driveways, Walkways, and Entrances: Keep driveways, parking garage, loading areas, and entrances serving premises clear and available to Owner, Owner's employees, and emergency vehicles at all times. Do not use these areas for parking or for storage of materials.
 - C. Condition of Existing Building: Maintain portions of existing building affected by construction operations in a weathertight condition throughout construction period. Repair damage caused by construction operations.
- 1.6 COORDINATION WITH OCCUPANTS
- A. Full Owner Occupancy: Owner will occupy site and existing buildings during entire construction period. Cooperate with Owner during construction operations to minimize conflicts and facilitate Owner usage. Perform the Work so as not to interfere with Owner's day-to-day operations. Maintain existing exits unless otherwise indicated.
- 1.7 WORK RESTRICTIONS
- A. Work Restrictions, General: Comply with restrictions on construction operations.
 1. Comply with limitations on use of public streets and with other requirements of authorities having jurisdiction.
 - B. Existing Utility Interruptions: Do not interrupt utilities serving facilities occupied by Owner or others unless permitted under the following conditions and then only after providing temporary utility services according to requirements indicated:
 1. Notify Owner not less than two days in advance of proposed utility interruptions.
 2. Obtain Owner's written permission before proceeding with utility interruptions.
 - C. Restricted Substances: Use of tobacco products and other controlled substances within the existing building is not permitted.
- 1.8 SPECIFICATION AND DRAWING CONVENTIONS
- A. Specification Content: The Specifications use certain conventions for the style of language and the intended meaning of certain terms, words, and phrases when used in particular situations. These conventions are as follows:
 1. Imperative mood and streamlined language are generally used in the Specifications. The words "shall," "shall be," or "shall comply with," depending on the context, are implied where a colon (:) is used within a sentence or phrase.
 2. Specification requirements are to be performed by Contractor unless specifically stated otherwise.
 - B. Division 01 General Requirements: Requirements of Sections in Division 01 apply to the Work of all Sections in the Specifications.

**Okaloosa County TDC – Destin Fort Walton Beach Convention Center
Exterior Accessibility**

PART 2 - PRODUCTS (Not Used)

PART 3 - EXECUTION (Not Used)

END OF SECTION 011000

**Okaloosa County TDC – Destin Fort Walton Beach Convention Center
Exterior Accessibility**

SECTION 012500 - SUBSTITUTION PROCEDURES

PART 1 - GENERAL

1.1 SUMMARY

- A. Section includes administrative and procedural requirements for substitutions.
- B. Related Requirements:
 - 1. Section 016000 "Product Requirements" for requirements for submitting comparable product submittals for products by listed manufacturers.

1.2 DEFINITIONS

- A. Substitutions: Changes in products, materials, equipment, and methods of construction from those required by the Contract Documents and proposed by Contractor.
 - 1. Substitutions for Cause: Changes proposed by Contractor that are required due to changed Project conditions, such as unavailability of product, regulatory changes, or unavailability of required warranty terms.
 - 2. Substitutions for Convenience: Changes proposed by Contractor or Owner that are not required in order to meet other Project requirements but may offer advantage to Contractor or Owner.

1.3 ACTION SUBMITTALS

- A. Substitution Requests: Submit three copies of each request for consideration. Identify product or fabrication or installation method to be replaced. Include Specification Section number and title and Drawing numbers and titles.
 - 1. Documentation: Show compliance with requirements for substitutions and the following, as applicable:
 - a. Statement indicating why specified product or fabrication or installation method cannot be provided, if applicable.
 - b. Coordination of information, including a list of changes or revisions needed to other parts of the Work and to construction performed by Owner and separate contractors that will be necessary to accommodate proposed substitution.
 - c. Detailed comparison of significant qualities of proposed substitutions with those of the Work specified. Include annotated copy of applicable Specification Section. Significant qualities may include attributes, such as performance, weight, size, durability, visual effect, sustainable design characteristics, warranties, and specific

**Okaloosa County TDC – Destin Fort Walton Beach Convention Center
Exterior Accessibility**

- features and requirements indicated. Indicate deviations, if any, from the Work specified.
- d. Product Data, including drawings and descriptions of products and fabrication and installation procedures.
 - e. Samples, where applicable or requested.
 - f. Certificates and qualification data, where applicable or requested.
 - g. List of similar installations for completed projects, with project names and addresses as well as names and addresses of architects and owners.
 - h. Material test reports from a qualified testing agency, indicating and interpreting test results for compliance with requirements indicated.
 - i. Research reports evidencing compliance with building code in effect for Project.
 - j. Detailed comparison of Contractor's construction schedule using proposed substitutions with products specified for the Work, including effect on the overall Contract Time. If specified product or method of construction cannot be provided within the Contract Time, include letter from manufacturer, on manufacturer's letterhead, stating date of receipt of purchase order, lack of availability, or delays in delivery.
 - k. Cost information, including a proposal of change, if any, in the Contract Sum.
 - l. Contractor's certification that proposed substitution complies with requirements in the Contract Documents, except as indicated in substitution request, is compatible with related materials and is appropriate for applications indicated.
 - m. Contractor's waiver of rights to additional payment or time that may subsequently become necessary because of failure of proposed substitution to produce indicated results.
2. Architect's Action: If necessary, Architect will request additional information or documentation for evaluation within seven days of receipt of a request for substitution. Architect will notify Contractor of acceptance or rejection of proposed substitution within 15 days of receipt of request, or seven days of receipt of additional information or documentation, whichever is later.
 - a. Forms of Acceptance: Change Order, Construction Change Directive, or Architect's Supplemental Instructions for minor changes in the Work.
 - b. Use product specified if Architect does not issue a decision on use of a proposed substitution within time allocated.
- 1.4 QUALITY ASSURANCE
- A. Compatibility of Substitutions: Investigate and document compatibility of proposed substitution with related products and materials. Engage a qualified testing agency to perform compatibility tests recommended by manufacturers.
- 1.5 PROCEDURES
- A. Coordination: Revise or adjust affected work as necessary to integrate work of the approved substitutions.

**Okaloosa County TDC – Destin Fort Walton Beach Convention Center
Exterior Accessibility**

1.6 SUBSTITUTIONS

- A. Substitutions for Cause: Submit requests for substitution immediately on discovery of need for change, but not later than 15 days prior to time required for preparation and review of related submittals.
1. Conditions: Architect will consider Contractor's request for substitution when the following conditions are satisfied. If the following conditions are not satisfied, Architect will return requests without action, except to record noncompliance with these requirements:
- a. Requested substitution is consistent with the Contract Documents and will produce indicated results.
 - b. Substitution request is fully documented and properly submitted.
 - c. Requested substitution will not adversely affect Contractor's construction schedule.
 - d. Requested substitution has received necessary approvals of authorities having jurisdiction.
 - e. Requested substitution is compatible with other portions of the Work.
 - f. Requested substitution has been coordinated with other portions of the Work.
 - g. Requested substitution provides specified warranty.
 - h. If requested substitution involves more than one contractor, requested substitution has been coordinated with other portions of the Work, is uniform and consistent, is compatible with other products, and is acceptable to all contractors involved.
- B. Substitutions for Convenience: Not allowed unless otherwise indicated.
- C. Substitutions for Convenience: Architect will consider requests for substitution if received within 60 days after the Notice to Proceed. Requests received after that time may be considered or rejected at discretion of Architect.
1. Conditions: Architect will consider Contractor's request for substitution when the following conditions are satisfied. If the following conditions are not satisfied, Architect will return requests without action, except to record noncompliance with these requirements:
- a. Requested substitution offers Owner a substantial advantage in cost, time, energy conservation, or other considerations, after deducting additional responsibilities Owner must assume. Owner's additional responsibilities may include compensation to Architect for redesign and evaluation services, increased cost of other construction by Owner, and similar considerations.
 - b. Requested substitution does not require extensive revisions to the Contract Documents.
 - c. Requested substitution is consistent with the Contract Documents and will produce indicated results.
 - d. Substitution request is fully documented and properly submitted.
 - e. Requested substitution will not adversely affect Contractor's construction schedule.
 - f. Requested substitution has received necessary approvals of authorities having jurisdiction.
 - g. Requested substitution is compatible with other portions of the Work.

**Okaloosa County TDC – Destin Fort Walton Beach Convention Center
Exterior Accessibility**

- h. Requested substitution has been coordinated with other portions of the Work.
- i. Requested substitution provides specified warranty.
- j. If requested substitution involves more than one contractor, requested substitution has been coordinated with other portions of the Work, is uniform and consistent, is compatible with other products, and is acceptable to all contractors involved.

PART 2 - PRODUCTS (Not Used)

PART 3 - EXECUTION (Not Used)

END OF SECTION 012500

**Okaloosa County TDC – Destin Fort Walton Beach Convention Center
Exterior Accessibility**

SECTION 012600 - CONTRACT MODIFICATION PROCEDURES

PART 1 - GENERAL

1.1 SUMMARY

- A. Section includes administrative and procedural requirements for handling and processing Contract modifications.

1.2 MINOR CHANGES IN THE WORK

- A. Architect will issue supplemental instructions authorizing minor changes in the Work, not involving adjustment to the Contract Sum or the Contract Time, on AIA Document G710.

1.3 PROPOSAL REQUESTS

- A. Owner-Initiated Proposal Requests: Architect will issue a detailed description of proposed changes in the Work that may require adjustment to the Contract Sum or the Contract Time. If necessary, the description will include supplemental or revised Drawings and Specifications.
 - 1. Work Change Proposal Requests issued by Architect are not instructions either to stop work in progress or to execute the proposed change.
 - 2. Within time specified in Proposal Request or 20 days, when not otherwise specified, after receipt of Proposal Request, submit a quotation estimating cost adjustments to the Contract Sum and the Contract Time necessary to execute the change.
 - a. Include a list of quantities of products required or eliminated and unit costs, with total amount of purchases and credits to be made. If requested, furnish survey data to substantiate quantities.
 - b. Indicate applicable taxes, delivery charges, equipment rental, and amounts of trade discounts.
 - c. Include costs of labor and supervision directly attributable to the change.
 - d. Include an updated Contractor's construction schedule that indicates the effect of the change, including, but not limited to, changes in activity duration, start and finish times, and activity relationship. Use available total float before requesting an extension of the Contract Time.
- B. Contractor-Initiated Proposals: If latent or changed conditions require modifications to the Contract, Contractor may initiate a claim by submitting a request for a change to Architect.
 - 1. Include a statement outlining reasons for the change and the effect of the change on the Work. Provide a complete description of the proposed change. Indicate the effect of the proposed change on the Contract Sum and the Contract Time.

**Okaloosa County TDC – Destin Fort Walton Beach Convention Center
Exterior Accessibility**

2. Include a list of quantities of products required or eliminated and unit costs, with total amount of purchases and credits to be made. If requested, furnish survey data to substantiate quantities.
3. Indicate applicable taxes, delivery charges, equipment rental, and amounts of trade discounts.
4. Include costs of labor and supervision directly attributable to the change.
5. Include an updated Contractor's construction schedule that indicates the effect of the change, including, but not limited to, changes in activity duration, start and finish times, and activity relationship. Use available total float before requesting an extension of the Contract Time.
6. Comply with requirements in Section 012500 "Substitution Procedures" if the proposed change requires substitution of one product or system for product or system specified.

1.4 CHANGE ORDER PROCEDURES

- A. On Owner's approval of a Work Change Proposal Request, Architect will issue a Change Order for signatures of Owner and Contractor on AIA Document G701.

1.5 CONSTRUCTION CHANGE DIRECTIVE

- A. Construction Change Directive: Architect may issue a Construction Change Directive on AIA Document G714. Construction Change Directive instructs Contractor to proceed with a change in the Work, for subsequent inclusion in a Change Order.
 1. Construction Change Directive contains a complete description of change in the Work. It also designates method to be followed to determine change in the Contract Sum or the Contract Time.
- B. Documentation: Maintain detailed records on a time and material basis of work required by the Construction Change Directive.
 1. After completion of change, submit an itemized account and supporting data necessary to substantiate cost and time adjustments to the Contract.

1.6 WORK CHANGE DIRECTIVE

- A. Work Change Directive: Architect may issue a Work Change Directive. Work Change Directive instructs Contractor to proceed with a change in the Work, for subsequent inclusion in a Change Order.
 1. Work Change Directive contains a complete description of change in the Work. It also designates method to be followed to determine change in the Contract Sum or the Contract Time.
- B. Documentation: Maintain detailed records on a time and material basis of work required by the Work Change Directive.

**Okaloosa County TDC – Destin Fort Walton Beach Convention Center
Exterior Accessibility**

1. After completion of change, submit an itemized account and supporting data necessary to substantiate cost and time adjustments to the Contract.

PART 2 - PRODUCTS (Not Used)

PART 3 - EXECUTION (Not Used)

END OF SECTION 012600

**Okaloosa County TDC – Destin Fort Walton Beach Convention Center
Exterior Accessibility**

Page left blank

**Okaloosa County TDC – Destin Fort Walton Beach Convention Center
Exterior Accessibility**

SECTION 013100 - PROJECT MANAGEMENT AND COORDINATION

PART 1 - GENERAL

1.1 RELATED DOCUMENTS

- A. Drawings and general provisions of the Contract, including General and Supplementary Conditions and other Division 01 Specification Sections, apply to this Section.

1.2 SUMMARY

- A. Section includes administrative provisions for coordinating construction operations on Project including, but not limited to, the following:
 - 1. General coordination procedures.
 - 2. Coordination drawings.
 - 3. RFIs.
 - 4. Digital project management procedures.
 - 5. Project meetings.
- B. Related Requirements:
 - 1. Section 017300 "Execution" for procedures for coordinating general installation and field-engineering services, including establishment of benchmarks and control points.

1.3 DEFINITIONS

- A. RFI: Request for Information. Request from Owner, Architect, or Contractor seeking information required by or clarifications of the Contract Documents.

1.4 INFORMATIONAL SUBMITTALS

- A. Subcontract List: Prepare a written summary identifying individuals or firms proposed for each portion of the Work, including those who are to furnish products or equipment fabricated to a special design. Include the following information in tabular form:
 - 1. Name, address, telephone number, and email address of entity performing subcontract or supplying products.
 - 2. Number and title of related Specification Section(s) covered by subcontract.
 - 3. Drawing number and detail references, as appropriate, covered by subcontract.

**Okaloosa County TDC – Destin Fort Walton Beach Convention Center
Exterior Accessibility**

1.5 GENERAL COORDINATION PROCEDURES

- A. Coordination: Coordinate construction operations included in different Sections of the Specifications to ensure efficient and orderly installation of each part of the Work. Coordinate construction operations included in different Sections that depend on each other for proper installation, connection, and operation.
1. Schedule construction operations in sequence required to obtain the best results where installation of one part of the Work depends on installation of other components, before or after its own installation.
 2. Coordinate installation of different components to ensure maximum performance and accessibility for required maintenance, service, and repair.
 3. Make adequate provisions to accommodate items scheduled for later installation.
- B. Administrative Procedures: Coordinate scheduling and timing of required administrative procedures with other construction activities to avoid conflicts and to ensure orderly progress of the Work. Such administrative activities include, but are not limited to, the following:
1. Preparation of Contractor's construction schedule.
 2. Preparation of the schedule of values.
 3. Installation and removal of temporary facilities and controls.
 4. Delivery and processing of submittals.
 5. Progress meetings.
 6. Preinstallation conferences.
 7. Project closeout activities.
 8. Startup and adjustment of systems.

1.6 COORDINATION DRAWINGS

- A. Coordination Drawings, General: Prepare coordination drawings according to requirements in individual Sections, and additionally where installation is not completely indicated on Shop Drawings, where limited space availability necessitates coordination, or if coordination is required to facilitate integration of products and materials fabricated or installed by more than one entity.
1. Content: Project-specific information, drawn accurately to a scale large enough to indicate and resolve conflicts. Do not base coordination drawings on standard printed data. Include the following information, as applicable:
 - a. Indicate functional and spatial relationships of components of architectural, structural, civil, mechanical, and electrical systems.
 - b. Indicate dimensions shown on Drawings. Specifically note dimensions that appear to be in conflict with submitted equipment and minimum clearance requirements. Provide alternative sketches to Architect indicating proposed resolution of such conflicts. Minor dimension changes and difficult installations will not be considered changes to the Contract.
- B. Coordination Drawing Organization: Organize coordination drawings as follows:

**Okaloosa County TDC – Destin Fort Walton Beach Convention Center
Exterior Accessibility**

1. Floor Plans and Reflected Ceiling Plans: Show architectural and structural elements, and mechanical, plumbing, fire-protection, fire-alarm, and electrical Work. Show locations of visible ceiling-mounted devices relative to acoustical ceiling grid. Supplement plan drawings with section drawings where required to adequately represent the Work.
2. Plenum Space: Indicate subframing for support of ceiling and wall systems, mechanical and electrical equipment, and related Work. Locate components within plenums to accommodate layout of light fixtures and other components indicated on Drawings. Indicate areas of conflict between light fixtures and other components.
3. Mechanical Rooms: Provide coordination drawings for mechanical rooms showing plans and elevations of mechanical, plumbing, fire-protection, fire-alarm, and electrical equipment.
4. Structural Penetrations: Indicate penetrations and openings required for all disciplines.
5. Slab Edge and Embedded Items: Indicate slab edge locations and sizes and locations of embedded items for metal fabrications, sleeves, anchor bolts, bearing plates, angles, door floor closers, slab depressions for floor finishes, curbs and housekeeping pads, and similar items.
6. Review: Architect will review coordination drawings to confirm that in general the Work is being coordinated, but not for the details of the coordination, which are Contractor's responsibility.

1.7 REQUEST FOR INFORMATION (RFI)

- A. General: Immediately on discovery of the need for additional information, clarification, or interpretation of the Contract Documents, Contractor shall prepare and submit an RFI in the form specified.
 1. Architect will return without response those RFIs submitted to Architect by other entities controlled by Contractor.
 2. Coordinate and submit RFIs in a prompt manner so as to avoid delays in Contractor's work or work of subcontractors.
- B. Content of the RFI: Include a detailed, legible description of item needing information or interpretation and the following:
 1. Project name.
 2. Project number.
 3. Date.
 4. Name of Contractor.
 5. Name of Architect.
 6. RFI number, numbered sequentially.
 7. RFI subject.
 8. Specification Section number and title and related paragraphs, as appropriate.
 9. Drawing number and detail references, as appropriate.
 10. Field dimensions and conditions, as appropriate.
 11. Contractor's suggested resolution. If Contractor's suggested resolution impacts the Contract Time or the Contract Sum, Contractor shall state impact in the RFI.
 12. Contractor's signature.

**Okaloosa County TDC – Destin Fort Walton Beach Convention Center
Exterior Accessibility**

13. Attachments: Include sketches, descriptions, measurements, photos, Product Data, Shop Drawings, coordination drawings, and other information necessary to fully describe items needing interpretation.
- C. RFI Forms: AIA Document G716 or software-generated form with substantially the same content as indicated above, acceptable to Architect].
- D. Architect's Action: Architect will review each RFI, determine action required, and respond. Allow seven working days for Architect's response for each RFI. RFIs received by Architect after 1:00 p.m. will be considered as received the following working day.
 1. The following Contractor-generated RFIs will be returned without action:
 - a. Requests for approval of submittals.
 - b. Requests for approval of substitutions.
 - c. Requests for approval of Contractor's means and methods.
 - d. Requests for coordination information already indicated in the Contract Documents.
 - e. Requests for adjustments in the Contract Time or the Contract Sum.
 - f. Requests for interpretation of Architect's actions on submittals.
 - g. Incomplete RFIs or inaccurately prepared RFIs.
 2. Architect's action may include a request for additional information, in which case Architect's time for response will date from time of receipt by Architect of additional information.
 3. Architect's action on RFIs that may result in a change to the Contract Time or the Contract Sum may be eligible for Contractor to submit Change Proposal according to Section 012600 "Contract Modification Procedures."
 - a. If Contractor believes the RFI response warrants change in the Contract Time or the Contract Sum, notify Architect in writing within 10 days of receipt of the RFI response.
- E. RFI Log: Prepare, maintain, and submit a tabular log of RFIs organized by the RFI number. Submit log weekly. Include the following:
 1. Project name.
 2. Name and address of Contractor.
 3. Name and address of Architect.
 4. RFI number including RFIs that were returned without action or withdrawn.
 5. RFI description.
 6. Date the RFI was submitted.
 7. Date Architect's response was received.
- F. On receipt of Architect's action, update the RFI log and immediately distribute the RFI response to affected parties. Review response and notify Architect within seven days if Contractor disagrees with response.

**Okaloosa County TDC – Destin Fort Walton Beach Convention Center
Exterior Accessibility**

1.8 DIGITAL PROJECT MANAGEMENT PROCEDURES

- A. Use of Architect's Digital Data Files: Digital data files of Architect's CAD drawings will be provided by Architect for Contractor's use during construction.
1. Digital data files may be used by Contractor in preparing coordination drawings, Shop Drawings, and Project record Drawings.
 2. Architect makes no representations as to the accuracy or completeness of digital data files as they relate to Contract Drawings.
 3. Contractor shall execute a data licensing agreement in the form of AIA Document C106 Digital Data Licensing Agreement.
 - a. Subcontractors, and other parties granted access by Contractor to Architect's digital data files shall execute a data licensing agreement in the form of AIA Document C106.
- B. PDF Document Preparation: Where PDFs are required to be submitted to Architect, prepare as follows:
1. Assemble complete submittal package into a single indexed file incorporating submittal requirements of a single Specification Section and transmittal form with links enabling navigation to each item.
 2. Name file with submittal number or other unique identifier, including revision identifier.
 3. Certifications: Where digitally submitted certificates and certifications are required, provide a digital signature with digital certificate on where indicated.

1.9 PROJECT MEETINGS

- A. General: Schedule and conduct meetings and conferences at Project site unless otherwise indicated.
- B. Preconstruction Conference: Architect will schedule and conduct a preconstruction conference before starting construction, at a time convenient to Owner and Architect, but no later than 15 days after execution of the Agreement.
1. Attendees: Authorized representatives of Owner, Architect, and their consultants; Contractor and its superintendent; major subcontractors; suppliers; and other concerned parties shall attend the conference. Participants at the conference shall be familiar with Project and authorized to conclude matters relating to the Work.
 2. Agenda: Discuss items of significance that could affect progress, including the following:
 - a. Responsibilities and personnel assignments.
 - b. Tentative construction schedule.
 - c. Phasing.
 - d. Critical work sequencing and long lead items.
 - e. Designation of key personnel and their duties.
 - f. Lines of communications.
 - g. Use of web-based Project software.

**Okaloosa County TDC – Destin Fort Walton Beach Convention Center
Exterior Accessibility**

- h. Procedures for processing field decisions and Change Orders.
 - i. Procedures for RFIs.
 - j. Procedures for testing and inspecting.
 - k. Procedures for processing Applications for Payment.
 - l. Distribution of the Contract Documents.
 - m. Submittal procedures.
 - n. Sustainable design requirements.
 - o. Preparation of Record Documents.
 - p. Use of the premises and existing building.
 - q. Work restrictions.
 - r. Working hours.
 - s. Owner's occupancy requirements.
 - t. Responsibility for temporary facilities and controls.
 - u. Procedures for moisture and mold control.
 - v. Procedures for disruptions and shutdowns.
 - w. Construction waste management and recycling.
 - x. Parking availability.
 - y. Office, work, and storage areas.
 - z. Equipment deliveries and priorities.
 - aa. First aid.
 - bb. Security.
 - cc. Progress cleaning.
3. Minutes: Entity responsible for conducting meeting will record and distribute meeting minutes.
- C. Preinstallation Conferences: Conduct a preinstallation conference at Project site before each construction activity when required by other sections and when required for coordination with other construction.
- 1. Attendees: Installer and representatives of manufacturers and fabricators involved in or affected by the installation and its coordination or integration with other materials and installations that have preceded or will follow, shall attend the meeting. Advise Architect, and Owner of scheduled meeting dates.
 - 2. Agenda: Review progress of other construction activities and preparations for the particular activity under consideration, including requirements for the following:
 - a. Contract Documents.
 - b. Options.
 - c. Related RFIs.
 - d. Related Change Orders.
 - e. Purchases.
 - f. Deliveries.
 - g. Submittals.
 - h. Sustainable design requirements.
 - i. Review of mockups.
 - j. Possible conflicts.
 - k. Compatibility requirements.
 - l. Time schedules.

**Okaloosa County TDC – Destin Fort Walton Beach Convention Center
Exterior Accessibility**

- m. Weather limitations.
 - n. Manufacturer's written instructions.
 - o. Warranty requirements.
 - p. Compatibility of materials.
 - q. Acceptability of substrates.
 - r. Temporary facilities and controls.
 - s. Space and access limitations.
 - t. Regulations of authorities having jurisdiction.
 - u. Testing and inspecting requirements.
 - v. Installation procedures.
 - w. Coordination with other work.
 - x. Required performance results.
 - y. Protection of adjacent work.
 - z. Protection of construction and personnel.
- 3. Record significant conference discussions, agreements, and disagreements, including required corrective measures and actions.
 - 4. Reporting: Distribute minutes of the meeting to each party present and to other parties requiring information.
 - 5. Do not proceed with installation if the conference cannot be successfully concluded. Initiate whatever actions are necessary to resolve impediments to performance of the Work and reconvene the conference at earliest feasible date.
- D. Progress Meetings: Conduct progress meetings at weekly intervals.
- 1. Coordinate dates of meetings with preparation of payment requests.
 - 2. Attendees: In addition to representatives of Owner and Architect, each contractor, subcontractor, supplier, and other entity concerned with current progress or involved in planning, coordination, or performance of future activities shall be represented at these meetings. All participants at the meeting shall be familiar with Project and authorized to conclude matters relating to the Work.
 - 3. Agenda: Review and correct or approve minutes of previous progress meeting. Review other items of significance that could affect progress. Include topics for discussion as appropriate to status of Project.
 - a. Contractor's Construction Schedule: Review progress since the last meeting. Determine whether each activity is on time, ahead of schedule, or behind schedule, in relation to Contractor's construction schedule. Determine how construction behind schedule will be expedited; secure commitments from parties involved to do so. Discuss whether schedule revisions are required to ensure that current and subsequent activities will be completed within the Contract Time.
 - 1) Review schedule for next period.
 - b. Review present and future needs of each entity present, including the following:
 - 1) Interface requirements.
 - 2) Sequence of operations.
 - 3) Resolution of BIM component conflicts.

**Okaloosa County TDC – Destin Fort Walton Beach Convention Center
Exterior Accessibility**

- 4) Status of submittals.
 - 5) Status of sustainable design documentation.
 - 6) Deliveries.
 - 7) Off-site fabrication.
 - 8) Access.
 - 9) Site use.
 - 10) Temporary facilities and controls.
 - 11) Progress cleaning.
 - 12) Quality and work standards.
 - 13) Status of correction of deficient items.
 - 14) Field observations.
 - 15) Status of RFIs.
 - 16) Status of Proposal Requests.
 - 17) Pending changes.
 - 18) Status of Change Orders.
 - 19) Pending claims and disputes.
 - 20) Documentation of information for payment requests.
4. Minutes: Entity responsible for conducting the meeting will record and distribute the meeting minutes to each party present and to parties requiring information.
- a. Schedule Updating: Revise Contractor's construction schedule after each progress meeting where revisions to the schedule have been made or recognized. Issue revised schedule concurrently with the report of each meeting.

PART 2 - PRODUCTS (Not Used)

PART 3 - EXECUTION (Not Used)

END OF SECTION 013100

**Okaloosa County TDC – Destin Fort Walton Beach Convention Center
Exterior Accessibility**

SECTION 014000 - QUALITY REQUIREMENTS

PART 1 - GENERAL

1.1 SUMMARY

- A. Section includes administrative and procedural requirements for quality assurance and quality control.
- B. Testing and inspection services are required to verify compliance with requirements specified or indicated. These services do not relieve Contractor of responsibility for compliance with the Contract Document requirements.
 - 1. Specified tests, inspections, and related actions do not limit Contractor's other quality-assurance and quality-control procedures that facilitate compliance with the Contract Document requirements.
 - 2. Requirements for Contractor to provide quality-assurance and quality-control services required by Architect, Owner or authorities having jurisdiction are not limited by provisions of this Section.

1.2 DEFINITIONS

- A. Experienced: When used with an entity or individual, "experienced" unless otherwise further described means having successfully completed a minimum of five previous projects similar in nature, size, and extent to this Project; being familiar with special requirements indicated; and having complied with requirements of authorities having jurisdiction.
- B. Field Quality-Control Tests and Inspections: Tests and inspections that are performed on-site for installation of the Work and for completed Work.
- C. Installer/Applicator/Erector: Contractor or another entity engaged by Contractor as an employee, Subcontractor, or Sub-subcontractor, to perform a particular construction operation, including installation, erection, application, assembly, and similar operations.
 - 1. Use of trade-specific terminology in referring to a Work result does not require that certain construction activities specified apply exclusively to specific trade(s).
 - 2. Integrated Exterior Mockups: Mockups of the exterior envelope constructed on-site as indicated in-place portions of permanent construction, consisting of multiple products, assemblies, and subassemblies, with cutaways enabling inspection of concealed portions of the Work.
 - a. Include each system, assembly, component, and part of the exterior wall to be constructed for the Project. Colors of components shall be those selected by the Architect for use in the Project.

**Okaloosa County TDC – Destin Fort Walton Beach Convention Center
Exterior Accessibility**

3. Product Mockups: Mockups that may include multiple products, materials, or systems specified in a single Section.
 4. In-Place Mockups: Mockups constructed on-site in their actual final location as part of permanent construction.
- D. Preconstruction Testing: Tests and inspections performed specifically for Project before products and materials are incorporated into the Work, to verify performance or compliance with specified criteria. Unless otherwise indicated, copies of reports of tests or inspections performed for other than the Project do not meet this definition.
- E. Product Tests: Tests and inspections that are performed by a nationally recognized testing laboratory (NRTL) according to 29 CFR 1910.7, by a testing agency accredited according to NIST's National Voluntary Laboratory Accreditation Program (NVLAP), or by a testing agency qualified to conduct product testing and acceptable to authorities having jurisdiction, to establish product performance and compliance with specified requirements.
- F. Source Quality-Control Tests and Inspections: Tests and inspections that are performed at the source; for example, plant, mill, factory, or shop.
- G. Testing Agency: An entity engaged to perform specific tests, inspections, or both. Testing laboratory shall have the same meaning as testing agency.
- H. Quality-Assurance Services: Activities, actions, and procedures performed before and during execution of the Work to guard against defects and deficiencies and substantiate that proposed construction will comply with requirements.
- I. Quality-Control Services: Tests, inspections, procedures, and related actions during and after execution of the Work to evaluate that actual products incorporated into the Work and completed construction comply with requirements. Contractor's quality-control services do not include contract administration activities performed by Architect.
- 1.3 DELEGATED-DESIGN SERVICES

- A. Performance and Design Criteria: Where professional design services or certifications by a design professional are specifically required of Contractor by the Contract Documents, provide products and systems complying with specific performance and design criteria indicated.
1. If criteria indicated are not sufficient to perform services or certification required, submit a written request for additional information to Architect.
- B. Delegated-Design Services Statement: Submit a statement, signed and sealed by the responsible design professional, for each product and system specifically assigned to Contractor to be designed or certified by a design professional, indicating that the products and systems are in compliance with performance and design criteria indicated. Include list of codes, loads, and other factors used in performing these services.

**Okaloosa County TDC – Destin Fort Walton Beach Convention Center
Exterior Accessibility**

1.4 CONFLICTING REQUIREMENTS

- A. **Conflicting Standards and Other Requirements:** If compliance with two or more standards or requirements is specified and the standards or requirements establish different or conflicting requirements for minimum quantities or quality levels, inform the Architect regarding the conflict and obtain clarification prior to proceeding with the Work. Refer conflicting requirements that are different, but apparently equal, to Architect for clarification before proceeding.
- B. **Minimum Quantity or Quality Levels:** The quantity or quality level shown or specified shall be the minimum provided or performed. The actual installation may comply exactly with the minimum quantity or quality specified, or it may exceed the minimum within reasonable limits. To comply with these requirements, indicated numeric values are minimum or maximum, as appropriate, for the context of requirements. Refer uncertainties to Architect for a decision before proceeding.

1.5 ACTION SUBMITTALS

- A. **Mockup Shop Drawings:** For integrated exterior mockups.
 - 1. Include plans, sections, elevations, and details, indicating materials and size of mockup construction.
 - 2. Indicate manufacturer and model number of individual components.
 - 3. Provide axonometric drawings for conditions difficult to illustrate in two dimensions.

1.6 INFORMATIONAL SUBMITTALS

- A. **Contractor's Statement of Responsibility:** When required by authorities having jurisdiction, submit copy of written statement of responsibility submitted to authorities having jurisdiction before starting work on the following systems:
 - 1. Main wind-force-resisting system or a wind-resisting component listed in the Statement of Special Inspections.
- B. **Testing Agency Qualifications:** For testing agencies specified in "Quality Assurance" Article to demonstrate their capabilities and experience. Include proof of qualifications in the form of a recent report on the inspection of the testing agency by a recognized authority.
- C. **Permits, Licenses, and Certificates:** For Owner's record, submit copies of permits, licenses, certifications, inspection reports, releases, jurisdictional settlements, notices, receipts for fee payments, judgments, correspondence, records, and similar documents established for compliance with standards and regulations bearing on performance of the Work.

1.7 REPORTS AND DOCUMENTS

- A. **Test and Inspection Reports:** Prepare and submit certified written reports specified in other Sections. Include the following:

**Okaloosa County TDC – Destin Fort Walton Beach Convention Center
Exterior Accessibility**

1. Date of issue.
 2. Project title and number.
 3. Name, address, telephone number, and email address of testing agency.
 4. Dates and locations of samples and tests or inspections.
 5. Names of individuals making tests and inspections.
 6. Description of the Work and test and inspection method.
 7. Identification of product and Specification Section.
 8. Complete test or inspection data.
 9. Test and inspection results and an interpretation of test results.
 10. Record of temperature and weather conditions at time of sample taking and testing and inspection.
 11. Comments or professional opinion on whether tested or inspected Work complies with the Contract Document requirements.
 12. Name and signature of laboratory inspector.
 13. Recommendations on retesting and reinspecting.
- B. Manufacturer's Technical Representative's Field Reports: Prepare written information documenting manufacturer's technical representative's tests and inspections specified in other Sections. Include the following:
1. Statement on condition of substrates and their acceptability for installation of product.
 2. Statement that products at Project site comply with requirements.
 3. Summary of installation procedures being followed, whether they comply with requirements and, if not, what corrective action was taken.
 4. Results of operational and other tests and a statement of whether observed performance complies with requirements.
 5. Other required items indicated in individual Specification Sections.
- C. Factory-Authorized Service Representative's Reports: Prepare written information documenting manufacturer's factory-authorized service representative's tests and inspections specified in other Sections. Include the following:
1. Statement that equipment complies with requirements.
 2. Results of operational and other tests and a statement of whether observed performance complies with requirements.
 3. Other required items indicated in individual Specification Sections.
- 1.8 QUALITY ASSURANCE
- A. Qualifications paragraphs in this article establish the minimum qualification levels required; individual Specification Sections specify additional requirements.
- B. Manufacturer Qualifications: A firm experienced in manufacturing products or systems similar to those indicated for this Project and with a record of successful in-service performance, as well as sufficient production capacity to produce required units. As applicable, procure products from manufacturers able to meet qualification requirements, warranty requirements, and technical or factory-authorized service representative requirements.

**Okaloosa County TDC – Destin Fort Walton Beach Convention Center
Exterior Accessibility**

- C. Fabricator Qualifications: A firm experienced in producing products similar to those indicated for this Project and with a record of successful in-service performance, as well as sufficient production capacity to produce required units.
- D. Installer Qualifications: A firm or individual experienced in installing, erecting, applying, or assembling work similar in material, design, and extent to that indicated for this Project, whose work has resulted in construction with a record of successful in-service performance.
- E. Professional Engineer Qualifications: A professional engineer who is legally qualified to practice in jurisdiction where Project is located and who is experienced in providing engineering services of the kind indicated. Engineering services are defined as those performed for installations of the system, assembly, or product that are similar in material, design, and extent to those indicated for this Project.
- F. Specialists: Certain Specification Sections require that specific construction activities shall be performed by entities who are recognized experts in those operations. Specialists shall satisfy qualification requirements indicated and shall be engaged for the activities indicated.
 - 1. Requirements of authorities having jurisdiction shall supersede requirements for specialists.
- G. Testing and Inspecting Agency Qualifications: An NRTL, an NVLAP, or an independent agency with the experience and capability to conduct testing and inspection indicated, as documented according to [ASTM E329] <Insert standard>; and with additional qualifications specified in individual Sections; and, where required by authorities having jurisdiction, that is acceptable to authorities.
- H. Manufacturer's Technical Representative Qualifications: An authorized representative of manufacturer who is trained and approved by manufacturer to observe and inspect installation of manufacturer's products that are similar in material, design, and extent to those indicated for this Project.
- I. Preconstruction Testing: Where testing agency is indicated to perform preconstruction testing for compliance with specified requirements for performance and test methods, comply with the following:
 - 1. Contractor responsibilities include the following:
 - a. Provide test specimens representative of proposed products and construction.
 - b. Submit specimens in a timely manner with sufficient time for testing and analyzing results to prevent delaying the Work.
 - 2. Testing Agency Responsibilities: Submit a certified written report of each test, inspection, and similar quality-assurance service to Architect, with copy to Contractor. Interpret tests and inspections and state in each report whether tested and inspected work complies with or deviates from the Contract Documents.
- J. Integrated Exterior Mockups: Construct integrated exterior mockup according to approved Shop Drawings. Coordinate installation of exterior envelope materials and products for which

**Okaloosa County TDC – Destin Fort Walton Beach Convention Center
Exterior Accessibility**

mockups are required in individual Specification Sections, along with supporting materials. Comply with requirements in "Mockups" Paragraph.

1. Coordinate construction of the mockup to allow observation of air barrier installation, flashings, air barrier integration with fenestration systems, and other portions of the building air/moisture barrier and drainage assemblies, prior to installation of veneer, cladding elements, and other components that will obscure the work.

1.9 QUALITY CONTROL

- A. Owner Responsibilities: Where quality-control services are indicated as Owner's responsibility, Owner will engage a qualified testing agency to perform these services.
 1. Owner will furnish Contractor with names, addresses, and telephone numbers of testing agencies engaged and a description of types of testing and inspection they are engaged to perform.
 2. Costs for retesting and reinspecting construction that replaces or is necessitated by Work that failed to comply with the Contract Documents will be charged to Contractor, and the Contract Sum will be adjusted by Change Order.
- B. Contractor Responsibilities: Tests and inspections not explicitly assigned to Owner are Contractor's responsibility. Perform additional quality-control activities, whether specified or not, to verify and document that the Work complies with requirements.
 1. Engage a qualified testing agency to perform quality-control services.
 - a. Contractor shall not employ same entity engaged by Owner, unless agreed to in writing by Owner.
 2. Notify testing agencies at least 24 hours in advance of time when Work that requires testing or inspection will be performed.
 3. Where quality-control services are indicated as Contractor's responsibility, submit a certified written report, in duplicate, of each quality-control service.
 4. Testing and inspection requested by Contractor and not required by the Contract Documents are Contractor's responsibility.
 5. Submit additional copies of each written report directly to authorities having jurisdiction, when they so direct.
- C. Retesting/Reinspecting: Regardless of whether original tests or inspections were Contractor's responsibility, provide quality-control services, including retesting and reinspecting, for construction that replaced Work that failed to comply with the Contract Documents.
- D. Testing Agency Responsibilities: Cooperate with Architect and Contractor in performance of duties. Provide qualified personnel to perform required tests and inspections.
 1. Notify Architect and Contractor promptly of irregularities or deficiencies observed in the Work during performance of its services.

**Okaloosa County TDC – Destin Fort Walton Beach Convention Center
Exterior Accessibility**

2. Determine the locations from which test samples will be taken and in which in-situ tests are conducted.
 3. Conduct and interpret tests and inspections and state in each report whether tested and inspected Work complies with or deviates from requirements.
 4. Submit a certified written report, in duplicate, of each test, inspection, and similar quality-control service through Contractor.
 5. Do not release, revoke, alter, or increase the Contract Document requirements or approve or accept any portion of the Work.
 6. Do not perform duties of Contractor.
- E. **Manufacturer's Field Services:** Where indicated, engage a factory-authorized service representative to inspect field-assembled components and equipment installation, including service connections. Report results in writing as specified in Section 013300 "Submittal Procedures."
- F. **Manufacturer's Technical Services:** Where indicated, engage a manufacturer's technical representative to observe and inspect the Work. Manufacturer's technical representative's services include participation in preinstallation conferences, examination of substrates and conditions, verification of materials, observation of Installer activities, inspection of completed portions of the Work, and submittal of written reports.
- G. **Contractor's Associated Requirements and Services:** Cooperate with agencies and representatives performing required tests, inspections, and similar quality-control services, and provide reasonable auxiliary services as requested. Notify agency sufficiently in advance of operations to permit assignment of personnel. Provide the following:
1. Access to the Work.
 2. Incidental labor and facilities necessary to facilitate tests and inspections.
 3. Adequate quantities of representative samples of materials that require testing and inspection. Assist agency in obtaining samples.
 4. Facilities for storage and field curing of test samples.
 5. Preliminary design mix proposed for use for material mixes that require control by testing agency.
 6. Security and protection for samples and for testing and inspection equipment at Project site.
- H. **Coordination:** Coordinate sequence of activities to accommodate required quality-assurance and quality-control services with a minimum of delay and to avoid necessity of removing and replacing construction to accommodate testing and inspection.
1. Schedule times for tests, inspections, obtaining samples, and similar activities.

**Okaloosa County TDC – Destin Fort Walton Beach Convention Center
Exterior Accessibility**

PART 2 - PRODUCTS (Not Used)

PART 3 - EXECUTION

3.1 TEST AND INSPECTION LOG

A. Test and Inspection Log: Prepare a record of tests and inspections. Include the following:

1. Date test or inspection was conducted.
2. Description of the Work tested or inspected.
3. Date test or inspection results were transmitted to Architect.
4. Identification of testing agency or special inspector conducting test or inspection.

B. Maintain log at Project site. Post changes and revisions as they occur. Provide access to test and inspection log for Architect's and authorities' having jurisdiction reference during normal working hours.

1. Submit log at Project closeout as part of Project Record Documents.

3.2 REPAIR AND PROTECTION

A. General: On completion of testing, inspection, sample taking, and similar services, repair damaged construction and restore substrates and finishes.

1. Provide materials and comply with installation requirements specified in other Specification Sections or matching existing substrates and finishes. Restore patched areas and extend restoration into adjoining areas with durable seams that are as invisible as possible. Comply with the Contract Document requirements for cutting and patching in Section 017300 "Execution."

B. Protect construction exposed by or for quality-control service activities.

C. Repair and protection are Contractor's responsibility, regardless of the assignment of responsibility for quality-control services.

END OF SECTION 014000

**Okaloosa County TDC – Destin Fort Walton Beach Convention Center
Exterior Accessibility**

SECTION 015000 - TEMPORARY FACILITIES AND CONTROLS

PART 1 - GENERAL

1.1 SUMMARY

- A. Section includes requirements for temporary utilities, support facilities, and security and protection facilities.
- B. Related Requirements:
 - 1. Section 011000 "Summary" for work restrictions and limitations on utility interruptions.

1.2 USE CHARGES

- A. General: Installation and removal of and use charges for temporary facilities shall be included in the Contract Sum unless otherwise indicated. Allow other entities engaged in the Project to use temporary services and facilities without cost, including, but not limited to, Owner's construction forces, Architect, occupants of Project, testing agencies, and authorities having jurisdiction.
- B. Water and Sewer Service from Existing System: Water from Owner's existing water system is available for use without metering and without payment of use charges. Provide connections and extensions of services as required for construction operations.
- C. Electric Power Service from Existing System: Electric power from Owner's existing system is available for use without metering and without payment of use charges. Provide connections and extensions of services as required for construction operations.

1.3 INFORMATIONAL SUBMITTALS

- A. Site Utilization Plan: Show temporary facilities, temporary utility lines and connections, staging areas, construction site entrances, vehicle circulation, and parking areas for construction personnel.
- B. Project Identification and Temporary Signs: Show fabrication and installation details, including plans, elevations, details, layouts, typestyles, graphic elements, and message content.
- C. Fire-Safety Program: Show compliance with requirements of NFPA 241 and authorities having jurisdiction. Indicate Contractor personnel responsible for management of fire-prevention program.
- D. Moisture-and Mold-Protection Plan: Describe procedures and controls for protecting materials and construction from water absorption and damage and mold.

**Okaloosa County TDC – Destin Fort Walton Beach Convention Center
Exterior Accessibility**

- E. Dust- and HVAC-Control Plan: Submit coordination drawing and narrative that indicates the dust- and HVAC-control measures proposed for use, proposed locations, and proposed time frame for their operation. Include the following:
1. Locations of dust-control partitions at each phase of work.
 2. HVAC system isolation schematic drawing.
 3. Location of proposed air-filtration system discharge.
 4. Waste-handling procedures.
 5. Other dust-control measures.

1.4 QUALITY ASSURANCE

- A. Electric Service: Comply with NECA, NEMA, and UL standards and regulations for temporary electric service. Install service to comply with NFPA 70.
- B. Tests and Inspections: Arrange for authorities having jurisdiction to test and inspect each temporary utility before use. Obtain required certifications and permits.
- C. Accessible Temporary Egress: Comply with applicable provisions in the United States Access Board's ADA-ABA Accessibility Guidelines and ICC/ANSI A117.1.

1.5 PROJECT CONDITIONS

- A. Temporary Use of Permanent Facilities: Engage Installer of each permanent service to assume responsibility for operation, maintenance, and protection of each permanent service during its use as a construction facility before Owner's acceptance, regardless of previously assigned responsibilities.

PART 2 - PRODUCTS

2.1 TEMPORARY FACILITIES

- A. Field Offices, General: Prefabricated or mobile units with serviceable finishes, temperature controls, and foundations adequate for normal loading.
- B. Common-Use Field Office: Of sufficient size to accommodate needs of Owner, Architect, and construction personnel office activities and to accommodate Project meetings specified in other Division 01 Sections. Keep office clean and orderly. Furnish and equip offices as follows:
1. Furniture required for Project-site documents including file cabinets, plan tables, plan racks, and bookcases.
 2. Drinking water and private toilet.
 3. Heating and cooling equipment necessary to maintain a uniform indoor temperature of **68 to 72 deg F (20 to 22 deg C)**.

**Okaloosa County TDC – Destin Fort Walton Beach Convention Center
Exterior Accessibility**

4. Lighting fixtures capable of maintaining average illumination of 20 fc (215 lx) at desk height.

2.2 EQUIPMENT

- A. Fire Extinguishers: Portable, UL rated; with class and extinguishing agent as required by locations and classes of fire exposures.
- B. HVAC Equipment: Unless Owner authorizes use of permanent HVAC system, provide vented, self-contained, liquid-propane-gas or fuel-oil heaters with individual space thermostatic control.
 1. Use of gasoline-burning space heaters, open-flame heaters, or salamander-type heating units is prohibited.
 2. Heating Units: Listed and labeled for type of fuel being consumed, by a qualified testing agency acceptable to authorities having jurisdiction, and marked for intended location and application.
 3. Permanent HVAC System: If Owner authorizes use of permanent HVAC system for temporary use during construction, provide filter with MERV of 8 at each return-air grille in system and remove at end of construction and clean HVAC system as required in Section 017700 "Closeout Procedures."]
- C. Air-Filtration Units: Primary and secondary HEPA-filter-equipped portable units with four-stage filtration. Provide single switch for emergency shutoff. Configure to run continuously.

PART 3 - EXECUTION

3.1 TEMPORARY FACILITIES, GENERAL

- A. Conservation: Coordinate construction and use of temporary facilities with consideration given to conservation of energy, water, and materials. Coordinate use of temporary utilities to minimize waste.
 1. Salvage materials and equipment involved in performance of, but not actually incorporated into, the Work. See other Sections for disposition of salvaged materials that are designated as Owner's property.

3.2 INSTALLATION, GENERAL

- A. Locate facilities where they will serve Project adequately and result in minimum interference with performance of the Work. Relocate and modify facilities as required by progress of the Work.
- B. Provide each facility ready for use when needed to avoid delay. Do not remove until facilities are no longer needed or are replaced by authorized use of completed permanent facilities.

**Okaloosa County TDC – Destin Fort Walton Beach Convention Center
Exterior Accessibility**

3.3 TEMPORARY UTILITY INSTALLATION

- A. General: Install temporary service or connect to existing service.
 - 1. Arrange with utility company, Owner, and existing users for time when service can be interrupted, if necessary, to make connections for temporary services.
- B. Sewers and Drainage: Provide temporary utilities to remove effluent lawfully.
 - 1. Connect temporary sewers to private system indicated as directed by authorities having jurisdiction.
- C. Water Service: Install water service and distribution piping in sizes and pressures adequate for construction.
- D. Sanitary Facilities: Provide temporary toilets, wash facilities, and drinking water for use of construction personnel. Comply with requirements of authorities having jurisdiction for type, number, location, operation, and maintenance of fixtures and facilities.
- E. Temporary Heating and Cooling: Provide temporary heating and cooling required by construction activities for curing or drying of completed installations or for protecting installed construction from adverse effects of low temperatures or high humidity. Select equipment that will not have a harmful effect on completed installations or elements being installed.
 - 1. Provide temporary dehumidification systems when required to reduce ambient and substrate moisture levels to level required to allow installation or application of finishes and their proper curing or drying.
- F. Isolation of Work Areas in Occupied Facilities: Prevent dust, fumes, and odors from entering occupied areas.
- G. Electric Power Service: Provide electric power service and distribution system of sufficient size, capacity, and power characteristics required for construction operations.
 - 1. Install electric power service overhead unless otherwise indicated.
- H. Lighting: Provide temporary lighting with local switching that provides adequate illumination for construction operations, observations, inspections, and traffic conditions.
 - 1. Install and operate temporary lighting that fulfills security and protection requirements without operating entire system.

3.4 SUPPORT FACILITIES INSTALLATION

- A. General: Comply with the following:

**Okaloosa County TDC – Destin Fort Walton Beach Convention Center
Exterior Accessibility**

1. Provide construction for temporary offices, shops, and sheds located within construction area or within **30 feet (9 m)** of building lines that is noncombustible according to ASTM E136. Comply with NFPA 241.
 2. Maintain support facilities until Architect schedules Substantial Completion inspection. Remove before Substantial Completion. Personnel remaining after Substantial Completion will be permitted to use permanent facilities, under conditions acceptable to Owner.
- B. Traffic Controls: Comply with requirements of authorities having jurisdiction.
1. Protect existing site improvements to remain including curbs, pavement, and utilities.
 2. Maintain access for fire-fighting equipment and access to fire hydrants.
- C. Parking: Use designated areas of Owner's existing parking areas for construction personnel.
- D. Project Signs: Provide Project signs as indicated. Unauthorized signs are not permitted.
1. Identification Signs: Provide Project identification signs as indicated on Drawings.
 2. Temporary Signs: Provide other signs as indicated and as required to inform public and individuals seeking entrance to Project.
 - a. Provide temporary, directional signs for construction personnel and visitors.
 3. Maintain and touch up signs so they are legible at all times.
- E. Waste Disposal Facilities: Provide waste-collection containers in sizes adequate to handle waste from construction operations. Comply with requirements of authorities having jurisdiction. Comply with progress cleaning requirements in Section 017300 "Execution."
- F. Lifts and Hoists: Provide facilities necessary for hoisting materials and personnel.
1. Truck cranes and similar devices used for hoisting materials are considered "tools and equipment" and not temporary facilities.
- G. Existing Stair Usage: Use of Owner's existing stairs will be permitted, provided stairs are cleaned and maintained in a condition acceptable to Owner. At Substantial Completion, restore stairs to condition existing before initial use.
1. Provide protective coverings, barriers, devices, signs, or other procedures to protect stairs and to maintain means of egress. If stairs become damaged, restore damaged areas so no evidence remains of correction work.
- 3.5 SECURITY AND PROTECTION FACILITIES INSTALLATION
- A. Protection of Existing Facilities: Protect existing vegetation, equipment, structures, utilities, and other improvements at Project site and on adjacent properties, except those indicated to be removed or altered. Repair damage to existing facilities.

**Okaloosa County TDC – Destin Fort Walton Beach Convention Center
Exterior Accessibility**

1. Where access to adjacent properties is required in order to affect protection of existing facilities, obtain written permission from adjacent property owner to access property for that purpose.
- B. Environmental Protection: Provide protection, operate temporary facilities, and conduct construction as required to comply with environmental regulations and that minimize possible air, waterway, and subsoil contamination or pollution or other undesirable effects.
- C. Pest Control: Engage pest-control service to recommend practices to minimize attraction and harboring of rodents, roaches, and other pests and to perform extermination and control procedures at regular intervals so Project will be free of pests and their residues at Substantial Completion. Perform control operations lawfully, using materials approved by authorities having jurisdiction.
- D. Site Enclosure Fence: Before construction operations begin, furnish and install site enclosure fence in a manner that will prevent people from easily entering site except by entrance gates.
 1. Extent of Fence: As required to enclose entire Project site or portion determined sufficient to accommodate construction operations.
 2. Maintain security by limiting number of keys and restricting distribution to authorized personnel. Furnish one set of keys to Owner.
- E. Security Enclosure and Lockup: Install temporary enclosure around partially completed areas of construction. Provide lockable entrances to prevent unauthorized entrance, vandalism, theft, and similar violations of security. Lock entrances at end of each workday.
- F. Barricades, Warning Signs, and Lights: Comply with requirements of authorities having jurisdiction for erecting structurally adequate barricades, including warning signs and lighting.
- G. Temporary Egress: Maintain temporary egress from existing occupied facilities as indicated and as required by authorities having jurisdiction.
- H. Temporary Enclosures: Provide temporary enclosures for protection of construction, in progress and completed, from exposure, foul weather, other construction operations, and similar activities. Provide temporary weathertight enclosure for building exterior.
 1. Where heating or cooling is needed and permanent enclosure is incomplete, insulate temporary enclosures.
- I. Temporary Partitions: Provide floor-to-ceiling dustproof partitions to limit dust and dirt migration and to separate areas occupied by Owner from fumes and noise.
 1. Construct dustproof partitions with gypsum wallboard with joints taped on occupied side, and fire-retardant-treated plywood on construction operations side.
 2. Where fire-resistance-rated temporary partitions are indicated or are required by authorities having jurisdiction, construct partitions according to the rated assemblies.
 3. Provide walk-off mats at each entrance through temporary partition.

**Okaloosa County TDC – Destin Fort Walton Beach Convention Center
Exterior Accessibility**

- J. Temporary Fire Protection: Install and maintain temporary fire-protection facilities of types needed to protect against reasonably predictable and controllable fire losses. Comply with NFPA 241; manage fire-prevention program.
1. Prohibit smoking in construction areas. Comply with additional limits on smoking specified in other Sections.
 2. Supervise welding operations, combustion-type temporary heating units, and similar sources of fire ignition according to requirements of authorities having jurisdiction.
 3. Develop and supervise an overall fire-prevention and -protection program for personnel at Project site. Review needs with local fire department and establish procedures to be followed. Instruct personnel in methods and procedures. Post warnings and information.
 4. Provide temporary standpipes and hoses for fire protection. Hang hoses with a warning sign stating that hoses are for fire-protection purposes only and are not to be removed. Match hose size with outlet size and equip with suitable nozzles.

3.6 MOISTURE AND MOLD CONTROL

- A. Contractor's Moisture-Protection Plan: Describe delivery, handling, storage, installation, and protection provisions for materials subject to water absorption or water damage.
1. Indicate procedures for discarding water-damaged materials, protocols for mitigating water intrusion into completed Work, and replacing water-damaged Work.
 2. Indicate sequencing of work that requires water, such as sprayed fire-resistive materials, plastering, and terrazzo grinding, and describe plans for dealing with water from these operations. Show procedures for verifying that wet construction has dried sufficiently to permit installation of finish materials.
 3. Indicate methods to be used to avoid trapping water in finished work.
- B. Exposed Construction Period: Before installation of weather barriers, when materials are subject to wetting and exposure and to airborne mold spores, protect as follows:
1. Protect porous materials from water damage.
 2. Protect stored and installed material from flowing or standing water.
 3. Keep porous and organic materials from coming into prolonged contact with concrete.
 4. Remove standing water from decks.
 5. Keep deck openings covered or dammed.
- C. Partially Enclosed Construction Period: After installation of weather barriers but before full enclosure and conditioning of building, when installed materials are still subject to infiltration of moisture and ambient mold spores, protect as follows:
1. Do not load or install drywall or other porous materials or components, or items with high organic content, into partially enclosed building.
 2. Keep interior spaces reasonably clean and protected from water damage.
 3. Periodically collect and remove waste containing cellulose or other organic matter.
 4. Discard or replace water-damaged material.
 5. Do not install material that is wet.
 6. Discard and replace stored or installed material that begins to grow mold.

**Okaloosa County TDC – Destin Fort Walton Beach Convention Center
Exterior Accessibility**

7. Perform work in a sequence that allows wet materials adequate time to dry before enclosing the material in gypsum board or other interior finishes.
- D. Controlled Construction Period: After completing and sealing of the building enclosure but prior to the full operation of permanent HVAC systems, maintain as follows:
1. Control moisture and humidity inside building by maintaining effective dry-in conditions.
 2. Use temporary or permanent HVAC system to control humidity within ranges specified for installed and stored materials.
 3. Comply with manufacturer's written instructions for temperature, relative humidity, and exposure to water limits.

3.7 OPERATION, TERMINATION, AND REMOVAL

- A. Supervision: Enforce strict discipline in use of temporary facilities. To minimize waste and abuse, limit availability of temporary facilities to essential and intended uses.
- B. Maintenance: Maintain facilities in good operating condition until removal.
1. Maintain operation of temporary enclosures, heating, cooling, humidity control, ventilation, and similar facilities on a 24-hour basis where required to achieve indicated results and to avoid possibility of damage.
- C. Temporary Facility Changeover: Do not change over from using temporary security and protection facilities to permanent facilities until Substantial Completion.
- D. Termination and Removal: Remove each temporary facility when need for its service has ended, when it has been replaced by authorized use of a permanent facility, or no later than Substantial Completion. Complete or, if necessary, restore permanent construction that may have been delayed because of interference with temporary facility. Repair damaged Work, clean exposed surfaces, and replace construction that cannot be satisfactorily repaired.
1. Materials and facilities that constitute temporary facilities are property of Contractor. Owner reserves right to take possession of Project identification signs.
 2. At Substantial Completion, repair, renovate, and clean permanent facilities used during construction period. Comply with final cleaning requirements specified in Section 017700 "Closeout Procedures."

END OF SECTION 015000

**Okaloosa County TDC – Destin Fort Walton Beach Convention Center
Exterior Accessibility**

SECTION 016000 - PRODUCT REQUIREMENTS

1.1 ACTION SUBMITTALS

- A. Comparable Product Requests: Architect will notify Contractor of approval or rejection within 15 days of receipt of request, or seven days of receipt of additional information.

1.2 PRODUCT DELIVERY, STORAGE, AND HANDLING

- A. Use means and methods that will prevent damage, deterioration, and loss, including theft.
- B. Store products to allow for inspection and measurement or counting of units.
- C. Provide for storage of materials and equipment by Owner.

1.3 PRODUCT WARRANTIES

- A. Manufacturer's disclaimers and limitations on product warranties do not relieve Contractor of obligations under requirements of the Contract Documents.
- B. Special Warranties: Prepare a written document that contains appropriate terms and identification, ready for execution.

1.4 PRODUCT SELECTION PROCEDURES

- A. Product Selection Procedures:
 - 1. Product: Product named that complies with requirements.
 - 2. Manufacturer/Source: Product by manufacturer or from source named that complies with requirements.
 - 3. Products: One of the products listed that complies with requirements. Comparable products will be considered unless otherwise indicated.
 - 4. Manufacturers: Product by one of the manufacturers listed that complies with requirements. Comparable products will be considered unless otherwise indicated.
 - 5. Basis-of-Design Product: Either the specified product or a comparable product by one of the other named manufacturers.
 - 6. Visual Matching Specification: Product that matches Architect's sample. Architect's decision will be final.
 - 7. Visual Selection Specification: Product (and manufacturer) that complies with other specified requirements. Architect will select color, gloss, pattern, density, or texture from manufacturer's product line that includes both standard and premium items.

**Okaloosa County TDC – Destin Fort Walton Beach Convention Center
Exterior Accessibility**

1.5 COMPARABLE PRODUCTS

A. Conditions for Consideration:

1. Product does not require revisions to the Contract Documents, is consistent with the Contract Documents and will produce the indicated results, and is compatible with other portions of the Work.
2. Comparison of proposed product with those named in the Specifications.
3. Product provides specified warranty.
4. Similar installations, if requested.
5. Samples, if requested.

END OF SECTION 016000

**Okaloosa County TDC – Destin Fort Walton Beach Convention Center
Exterior Accessibility**

SECTION 017300 - EXECUTION

PART 1 - GENERAL

1.1 SUMMARY

- A. Section includes general administrative and procedural requirements governing execution of the Work including, but not limited to, the following:
 - 1. Construction layout.
 - 2. Field engineering and surveying.
 - 3. Installation of the Work.
 - 4. Cutting and patching.
 - 5. Progress cleaning.
 - 6. Starting and adjusting.
 - 7. Protection of installed construction.

- B. Related Requirements:
 - 1. Section 011000 "Summary" for limits on use of Project site.

1.2 INFORMATIONAL SUBMITTALS

- A. Landfill Receipts: Submit copy of receipts issued by a landfill facility, licensed to accept hazardous materials, for hazardous waste disposal.

1.3 QUALITY ASSURANCE

- A. Cutting and Patching: Comply with requirements for and limitations on cutting and patching of construction elements.
 - 1. Structural Elements: When cutting and patching structural elements, notify Architect of locations and details of cutting and await directions from Architect before proceeding. Shore, brace, and support structural elements during cutting and patching. Do not cut and patch structural elements in a manner that could change their load-carrying capacity or increase deflection.
 - 2. Operational Elements: Do not cut and patch operating elements and related components in a manner that results in reducing their capacity to perform as intended or that results in increased maintenance or decreased operational life or safety.
 - 3. Other Construction Elements: Do not cut and patch other construction elements or components in a manner that could change their load-carrying capacity, that results in reducing their capacity to perform as intended, or that results in increased maintenance or decreased operational life or safety.

**Okaloosa County TDC – Destin Fort Walton Beach Convention Center
Exterior Accessibility**

4. Visual Elements: Do not cut and patch construction in a manner that results in visual evidence of cutting and patching. Do not cut and patch exposed construction in a manner that would, in Architect's opinion, reduce the building's aesthetic qualities. Remove and replace construction that has been cut and patched in a visually unsatisfactory manner.
- B. Manufacturer's Installation Instructions: Obtain and maintain on-site manufacturer's written recommendations and instructions for installation of products and equipment.

PART 2 - PRODUCTS

2.1 MATERIALS

- A. In-Place Materials: Use materials for patching identical to in-place materials. For exposed surfaces, use materials that visually match in-place adjacent surfaces to the fullest extent possible.
1. If identical materials are unavailable or cannot be used, use materials that, when installed, will provide a match acceptable to Architect for the visual and functional performance of in-place materials.

PART 3 - EXECUTION

3.1 EXAMINATION

- A. Existing Conditions: The existence and location of utilities and construction indicated as existing are not guaranteed. Before beginning work, investigate and verify the existence and location of utilities, mechanical and electrical systems, and other construction affecting the Work.
1. Before construction, verify the location and points of connection of sanitary sewer, storm sewer, and water-service piping; underground electrical services; and other utilities.
 2. Furnish location data for work related to Project that must be performed by public utilities serving Project site.
- B. Examination and Acceptance of Conditions: Before proceeding with each component of the Work, examine substrates, areas, and conditions, with Installer or Applicator present where indicated, for compliance with requirements for installation tolerances and other conditions affecting performance. Record observations.
1. Examine roughing-in for mechanical and electrical systems to verify actual locations of connections before equipment and fixture installation.
 2. Examine walls, floors, and roofs for suitable conditions where products and systems are to be installed.
 3. Verify compatibility with and suitability of substrates, including compatibility with existing finishes or primers.

**Okaloosa County TDC – Destin Fort Walton Beach Convention Center
Exterior Accessibility**

- C. Proceed with installation only after unsatisfactory conditions have been corrected. Proceeding with the Work indicates acceptance of surfaces and conditions.

3.2 PREPARATION

- A. Existing Utility Information: Furnish information to Owner that is necessary to adjust, move, or relocate existing utility structures, utility poles, lines, services, or other utility appurtenances located in or affected by construction. Coordinate with authorities having jurisdiction.
- B. Field Measurements: Take field measurements as required to fit the Work properly. Recheck measurements before installing each product. Where portions of the Work are indicated to fit to other construction, verify dimensions of other construction by field measurements before fabrication. Coordinate fabrication schedule with construction progress to avoid delaying the Work.
- C. Space Requirements: Verify space requirements and dimensions of items shown diagrammatically on Drawings.
- D. Review of Contract Documents and Field Conditions: Immediately on discovery of the need for clarification of the Contract Documents caused by differing field conditions outside the control of Contractor, submit a request for information to Architect.

3.3 CONSTRUCTION LAYOUT

- A. Verification: Before proceeding to lay out the Work, verify layout information shown on Drawings. If discrepancies are discovered, notify Architect promptly.
- B. General: Lay out the Work using accepted surveying practices.
 - 1. Establish benchmarks and control points to set lines and levels of construction and elsewhere as needed to locate each element of Project.
 - 2. Establish limits on use of Project site.
 - 3. Establish dimensions within tolerances indicated. Do not scale Drawings to obtain required dimensions.
 - 4. Inform installers of lines and levels to which they must comply.
 - 5. Check the location, level and plumb, of every major element as the Work progresses.
 - 6. Notify Architect when deviations from required lines and levels exceed allowable tolerances.

3.4 INSTALLATION

- A. General: Locate the Work and components of the Work accurately, in correct alignment and elevation, as indicated.
 - 1. Make vertical work plumb and make horizontal work level.

**Okaloosa County TDC – Destin Fort Walton Beach Convention Center
Exterior Accessibility**

2. Where space is limited, install components to maximize space available for maintenance and ease of removal for replacement.
 3. Conceal pipes, ducts, and wiring in finished areas unless otherwise indicated.
- B. Comply with manufacturer's written instructions and recommendations for installing products in applications indicated.
- C. Install products at the time and under conditions that will ensure the best possible results. Maintain conditions required for product performance until Substantial Completion.
- D. Conduct construction operations so no part of the Work is subjected to damaging operations or loading in excess of that expected during normal conditions of occupancy.
- E. Sequence the Work and allow adequate clearances to accommodate movement of construction items on site and placement in permanent locations.
- F. Tools and Equipment: Where possible, select tools or equipment that minimize production of excessive noise levels.
- G. Templates: Obtain and distribute to the parties involved templates for work specified to be factory prepared and field installed. Check Shop Drawings of other portions of the Work to confirm that adequate provisions are made for locating and installing products to comply with indicated requirements.
- H. Attachment: Provide blocking and attachment plates and anchors and fasteners of adequate size and number to securely anchor each component in place, accurately located and aligned with other portions of the Work. Where size and type of attachments are not indicated, verify size and type required for load conditions.
1. Mounting Heights: Where mounting heights are not indicated, mount components at heights directed by Architect.
 2. Allow for building movement, including thermal expansion and contraction.
 3. Coordinate installation of anchorages. Furnish setting drawings, templates, and directions for installing anchorages, including sleeves, concrete inserts, anchor bolts, and items with integral anchors, that are to be embedded in concrete or masonry. Deliver such items to Project site in time for installation.
- I. Joints: Make joints of uniform width. Where joint locations in exposed work are not indicated, arrange joints for the best visual effect. Fit exposed connections together to form hairline joints.
- J. Remove and replace damaged, defective, or non-conforming Work.

3.5 CUTTING AND PATCHING

- A. Cutting and Patching, General: Employ skilled workers to perform cutting and patching. Proceed with cutting and patching at the earliest feasible time, and complete without delay.

**Okaloosa County TDC – Destin Fort Walton Beach Convention Center
Exterior Accessibility**

1. Cut in-place construction to provide for installation of other components or performance of other construction, and subsequently patch as required to restore surfaces to their original condition.
- B. Existing Warranties: Remove, replace, patch, and repair materials and surfaces cut or damaged during installation or cutting and patching operations, by methods and with materials so as not to void existing warranties.
- C. Temporary Support: Provide temporary support of work to be cut.
- D. Protection: Protect in-place construction during cutting and patching to prevent damage. Provide protection from adverse weather conditions for portions of Project that might be exposed during cutting and patching operations.
- E. Adjacent Occupied Areas: Where interference with use of adjoining areas or interruption of free passage to adjoining areas is unavoidable, coordinate cutting and patching according to requirements in Section 011000 "Summary."
- F. Existing Utility Services and Mechanical/Electrical Systems: Where existing services/systems are required to be removed, relocated, or abandoned, bypass such services/systems before cutting to minimize or prevent interruption to occupied areas.
- G. Cutting: Cut in-place construction by sawing, drilling, breaking, chipping, grinding, and similar operations, including excavation, using methods least likely to damage elements retained or adjoining construction. If possible, review proposed procedures with original Installer; comply with original Installer's written recommendations.
 1. In general, use hand or small power tools designed for sawing and grinding, not hammering and chopping. Cut holes and slots neatly to minimum size required, and with minimum disturbance of adjacent surfaces. Temporarily cover openings when not in use.
 2. Finished Surfaces: Cut or drill from the exposed or finished side into concealed surfaces.
 3. Concrete and Masonry: Cut using a cutting machine, such as an abrasive saw or a diamond-core drill.
 4. Excavating and Backfilling: Comply with requirements in applicable Sections where required by cutting and patching operations.
 5. Mechanical and Electrical Services: Cut off pipe or conduit in walls or partitions to be removed. Cap, valve, or plug and seal remaining portion of pipe or conduit to prevent entrance of moisture or other foreign matter after cutting.
 6. Proceed with patching after construction operations requiring cutting are complete.
- H. Patching: Patch construction by filling, repairing, refinishing, closing up, and similar operations following performance of other work. Patch with durable seams that are as invisible as practicable. Provide materials and comply with installation requirements specified in other Sections, where applicable.
 1. Inspection: Where feasible, test and inspect patched areas after completion to demonstrate physical integrity of installation.

**Okaloosa County TDC – Destin Fort Walton Beach Convention Center
Exterior Accessibility**

2. Exposed Finishes: Restore exposed finishes of patched areas and extend finish restoration into retained adjoining construction in a manner that will minimize evidence of patching and refinishing.
 3. Floors and Walls: Where walls or partitions that are removed extend one finished area into another, patch and repair floor and wall surfaces in the new space. Provide an even surface of uniform finish, color, texture, and appearance. Remove in-place floor and wall coverings and replace with new materials, if necessary, to achieve uniform color and appearance.
 4. Ceilings: Patch, repair, or rehang in-place ceilings as necessary to provide an even-plane surface of uniform appearance.
 5. Exterior Building Enclosure: Patch components in a manner that restores enclosure to a weathertight condition and ensures thermal and moisture integrity of building enclosure.
- I. Cleaning: Clean areas and spaces where cutting and patching are performed. Remove paint, mortar, oils, putty, and similar materials from adjacent finished surfaces.

3.6 PROGRESS CLEANING

- A. General: Clean Project site and work areas daily, including common areas. Enforce requirements strictly. Dispose of materials lawfully.
1. Comply with requirements in NFPA 241 for removal of combustible waste materials and debris.
 2. Do not hold waste materials more than seven days during normal weather or three days if the temperature is expected to rise above 80 deg F (27 deg C).
 3. Containerize hazardous and unsanitary waste materials separately from other waste. Mark containers appropriately and dispose of legally, according to regulations.
 - a. Use containers intended for holding waste materials of type to be stored.
 4. Coordinate progress cleaning for joint-use areas where Contractor and other contractors are working concurrently.
- B. Site: Maintain Project site free of waste materials and debris.
- C. Work Areas: Clean areas where work is in progress to the level of cleanliness necessary for proper execution of the Work.
1. Remove liquid spills promptly.
 2. Where dust would impair proper execution of the Work, broom-clean or vacuum the entire work area, as appropriate.
- D. Installed Work: Keep installed work clean. Clean installed surfaces according to written instructions of manufacturer or fabricator of product installed, using only cleaning materials specifically recommended. If specific cleaning materials are not recommended, use cleaning materials that are not hazardous to health or property and that will not damage exposed surfaces.
- E. Concealed Spaces: Remove debris from concealed spaces before enclosing the space.

**Okaloosa County TDC – Destin Fort Walton Beach Convention Center
Exterior Accessibility**

- F. Exposed Surfaces in Finished Areas: Clean exposed surfaces and protect as necessary to ensure freedom from damage and deterioration at time of Substantial Completion.
- G. Waste Disposal: Do not bury or burn waste materials on-site. Do not wash waste materials down sewers or into waterways.
- H. During handling and installation, clean and protect construction in progress and adjoining materials already in place. Apply protective covering where required to ensure protection from damage or deterioration at Substantial Completion.
- I. Clean and provide maintenance on completed construction as frequently as necessary through the remainder of the construction period. Adjust and lubricate operable components to ensure operability without damaging effects.
- J. Limiting Exposures: Supervise construction operations to ensure that no part of the construction, completed or in progress, is subject to harmful, dangerous, damaging, or otherwise deleterious exposure during the construction period.

3.7 PROTECTION OF INSTALLED CONSTRUCTION

- A. Provide final protection and maintain conditions that ensure installed Work is without damage or deterioration at time of Substantial Completion.
- B. Protection of Existing Items: Provide protection and ensure that existing items to remain undisturbed by construction are maintained in condition that existed at commencement of the Work.
- C. Comply with manufacturer's written instructions for temperature and relative humidity.

END OF SECTION 017300

**Okaloosa County TDC – Destin Fort Walton Beach Convention Center
Exterior Accessibility**

Page left blank

**Okaloosa County TDC – Destin Fort Walton Beach Convention Center
Exterior Accessibility**

SECTION 024119 - SELECTIVE DEMOLITION

PART 1 - GENERAL

1.1 SUMMARY

A. Section Includes:

1. Demolition and removal of selected portions of site, building or structure.
2. Demolition and removal of selected system elements.
3. Salvage of existing items to be reused or recycled.

1.2 MATERIALS OWNERSHIP

- A. Unless otherwise indicated, demolition waste becomes property of Contractor.

1.3 PREINSTALLATION MEETINGS

- A. Predemolition Conference: Conduct conference at Project site.

1.4 INFORMATIONAL SUBMITTALS

- A. Survey: Submit survey of conditions of the building and systems to be replaced.
- B. Proposed Protection Measures: Submit report, including Drawings, that indicates the measures proposed for protecting individuals and property, for environmental protection, for dust control and for noise control. Indicate proposed locations and construction of barriers.
- C. Schedule of selective demolition activities with starting and ending dates for each activity.
- D. Predemolition photographs or video.

1.5 CLOSEOUT SUBMITTALS

- A. Inventory of items that have been removed and salvaged.

1.6 FIELD CONDITIONS

- A. Owner will occupy portions of building immediately adjacent to selective demolition area. Conduct selective demolition so Owner's operations will not be disrupted.

**Okaloosa County TDC – Destin Fort Walton Beach Convention Center
Exterior Accessibility**

- B. Conditions existing at time of inspection for bidding purpose will be maintained by Owner as far as practical.
- C. Notify Architect of discrepancies between existing conditions and Drawings before proceeding with selective demolition.
- D. Hazardous Materials: It is not expected that hazardous materials will be encountered in the Work.
 - 1. If suspected hazardous materials are encountered, do not disturb; immediately notify Architect and Owner. Hazardous materials will be removed by Owner under a separate contract.
- E. Storage or sale of removed items or materials on-site is not permitted.
- F. Utility Service: Maintain existing utilities indicated to remain in service and protect them against damage during selective demolition operations.
 - 1. Maintain fire-protection facilities in service during selective demolition operations.
- G. Arrange selective demolition schedule so as not to interfere with Owner's operations.

1.7 WARRANTY

- A. Existing Warranties: Remove, replace, patch, and repair materials and surfaces cut or damaged during selective demolition, by methods and with materials and using approved contractors so as not to void existing warranties.

PART 2 - PRODUCTS

2.1 PERFORMANCE REQUIREMENTS

- A. Regulatory Requirements: Comply with governing EPA notification regulations before beginning selective demolition. Comply with hauling and disposal regulations of authorities having jurisdiction.
- B. Standards: Comply with ASSE A10.6 and NFPA 241.

PART 3 - EXECUTION

3.1 EXAMINATION

- A. Verify that utilities have been disconnected and capped before starting selective demolition operations.

**Okaloosa County TDC – Destin Fort Walton Beach Convention Center
Exterior Accessibility**

- B. Perform a survey of condition of building to determine whether removing any element might result in structural deficiency or unplanned collapse of any portion of structure or adjacent structures during selective building demolition operations.
- C. Inventory and record the condition of items to be removed and salvaged.

3.2 UTILITY SERVICES AND MECHANICAL/ELECTRICAL SYSTEMS

- A. Existing Services/Systems to Remain: Maintain services/systems indicated to remain and protect them against damage.
- B. Existing Services/Systems to Be Removed, Relocated, or Abandoned: Locate, identify, disconnect, and seal or cap off utility services and mechanical/electrical systems serving areas to be selectively demolished.
 - 1. Owner will arrange to shut off indicated services/systems when requested by Contractor.
 - 2. Arrange to shut off utilities with utility companies.
 - 3. If services/systems are required to be removed, relocated, or abandoned, provide temporary services/systems that bypass area of selective demolition and that maintain continuity of services/systems to other parts of building.
 - 4. Disconnect, demolish, and remove fire-suppression systems, plumbing, and equipment, and components indicated on Drawings to be removed.
 - a. Piping to Be Removed: Remove portion of piping indicated to be removed and cap or plug remaining piping with same or compatible piping material.
 - b. Piping to Be Abandoned in Place: Drain piping and cap or plug piping with same or compatible piping material and leave in place.
 - c. Equipment to Be Removed: Disconnect and cap services and remove equipment.
 - d. Equipment to Be Removed and Reinstalled: Disconnect and cap services and remove, clean, and store equipment; when appropriate, reinstall, reconnect, and make equipment operational.
 - e. Equipment to Be Removed and Salvaged: Disconnect and cap services and remove equipment and deliver to Owner.

3.3 PROTECTION

- A. Temporary Protection: Provide temporary barricades and other protection required to prevent injury to people and damage to adjacent buildings and facilities to remain.
- B. Temporary Shoring: Design, provide, and maintain shoring, bracing, and structural supports as required to preserve stability and prevent movement, settlement, or collapse of construction and finishes to remain, and to prevent unexpected or uncontrolled movement or collapse of construction being demolished.
- C. Remove temporary barricades and protections where hazards no longer exist.

**Okaloosa County TDC – Destin Fort Walton Beach Convention Center
Exterior Accessibility**

3.4 SELECTIVE DEMOLITION

- A. General: Demolish and remove existing construction only to the extent required by new construction and as indicated. Use methods required to complete the Work within limitations of governing regulations and as follows:
1. Neatly cut openings and holes plumb, square, and true to dimensions required. Use cutting methods least likely to damage construction to remain or adjoining construction. Use hand tools or small power tools designed for sawing or grinding, not hammering and chopping. Temporarily cover openings to remain.
 2. Cut or drill from the exposed or finished side into concealed surfaces to avoid marring existing finished surfaces.
 3. Do not use cutting torches until work area is cleared of flammable materials. At concealed spaces, such as duct and pipe interiors, verify condition and contents of hidden space before starting flame-cutting operations. Maintain portable fire-suppression devices during flame-cutting operations.
 4. Maintain fire watch during and for at least 24 hours after flame-cutting operations.
 5. Locate selective demolition equipment and remove debris and materials so as not to impose excessive loads on supporting walls, floors, or framing.
 6. Dispose of demolished items and materials promptly.
- B. Site Access and Temporary Controls: Conduct selective demolition and debris-removal operations to ensure minimum interference with roads, streets, walks, walkways, and other adjacent occupied and used facilities.
- C. Removed and Salvaged Items:
1. Clean salvaged items.
 2. Pack or crate items after cleaning. Identify contents of containers.
 3. Store items in a secure area until delivery to Owner.
 4. Transport items to Owner's storage area designated by Owner.
 5. Protect items from damage during transport and storage.
- D. Removed and Reinstalled Items:
1. Clean and repair items to functional condition adequate for intended reuse.
 2. Pack or crate items after cleaning and repairing. Identify contents of containers.
 3. Protect items from damage during transport and storage.
 4. Reinstall items in locations indicated. Comply with installation requirements for new materials and equipment. Provide connections, supports, and miscellaneous materials necessary to make item functional for use indicated.
- E. Existing Items to Remain: Protect construction indicated to remain against damage and soiling during selective demolition. When permitted by Architect, items may be removed to a suitable, protected storage location during selective demolition and cleaned and reinstalled in their original locations after selective demolition operations are complete.

**Okaloosa County TDC – Destin Fort Walton Beach Convention Center
Exterior Accessibility**

3.5 CLEANING

- A. Remove demolition waste materials from Project site and dispose of them in an EPA-approved construction and demolition waste landfill acceptable to authorities having jurisdiction.
 - 1. Do not allow demolished materials to accumulate on-site.
 - 2. Remove and transport debris in a manner that will prevent spillage on adjacent surfaces and areas.
- B. Burning: Do not burn demolished materials.
- C. Clean adjacent structures and improvements of dust, dirt, and debris caused by selective demolition operations. Return adjacent areas to condition existing before selective demolition operations began.

END OF SECTION 024119

**Okaloosa County TDC – Destin Fort Walton Beach Convention Center
Exterior Accessibility**

Page Left Blank

**Okaloosa County TDC – Destin Fort Walton Beach Convention Center
Exterior Accessibility**

SECTION 055213 - PIPE AND TUBE RAILINGS

PART 1 - GENERAL

1.1 SUMMARY

- A. Section Includes:
 - 1. Aluminum handrails and guard railings.

1.2 ACTION SUBMITTALS

- A. Product Data:
 - 1. Manufacturer's product lines of mechanically connected railings.
 - 2. Handrail brackets.
 - 3. Nonshrink, nonmetallic grout.
 - 4. Anchoring cement.
 - 5. Metal finishes.
- B. Shop Drawings: Include plans, elevations, sections, details, and attachments to other work.
- C. Samples: For each type of exposed finish.
- D. Delegated-Design Submittal: For railings, including analysis data signed and sealed by the qualified professional engineer responsible for their preparation.

1.3 INFORMATIONAL SUBMITTALS

- A. Qualification Data: For delegated-design professional engineer.
- B. Welding certificates.
- C. Product Test Reports: For tests on railings performed by a qualified testing agency, in accordance with ASTM E894 and ASTM E935.

1.4 QUALITY ASSURANCE

- A. Welding Qualifications: Qualify procedures and personnel in accordance with the following:
 - 1. AWS D1.2/D1.2M, "Structural Welding Code - Aluminum."

**Okaloosa County TDC – Destin Fort Walton Beach Convention Center
Exterior Accessibility**

PART 2 - PRODUCTS**2.1 PERFORMANCE REQUIREMENTS**

- A. Delegated Design: Engage a qualified professional engineer, as defined in Section 014000 "Quality Requirements," to design railings, including attachment to building construction.
- B. Structural Performance: Railings, including attachment to building construction, shall withstand the effects of gravity loads and the following loads and stresses within limits and under conditions indicated:
 - 1. Handrails and Top Rails of Guards:
 - a. Uniform load of **50 lbf/ ft. (0.73 kN/m)** applied in any direction.
 - b. Concentrated load of **200 lbf (0.89 kN)** applied in any direction.
 - c. Uniform and concentrated loads need not be assumed to act concurrently.
 - 2. Infill of Guards:
 - a. Concentrated load of **50 lbf (0.22 kN)** applied horizontally on an area of **1 sq. ft. (0.093 sq. m)**.
 - b. Infill load and other loads need not be assumed to act concurrently.

2.2 METALS, GENERAL

- A. Metal Surfaces, General: Provide materials with smooth surfaces, without seam marks, roller marks, rolled trade names, stains, discolorations, or blemishes.
- B. Brackets, Flanges, and Anchors: Cast or formed metal of same type of material and finish as supported rails unless otherwise indicated.
 - 1. Provide type of bracket with flange tapped for concealed anchorage to threaded hanger bolt and that provides **1-1/2-inch (38-mm)** clearance from inside face of handrail to finished wall surface.

2.3 ALUMINUM RAILINGS

- A. Aluminum, General: Provide alloy and temper recommended by aluminum producer and finisher for type of use and finish indicated, and with not less than the strength and durability properties of alloy and temper designated below for each aluminum form required.
- B. Extruded Bars and Tubing: **ASTM B221 (ASTM B221M)**, Alloy 6063-T5/T52.
- C. Drawn Seamless Tubing: **ASTM B210/B210M**, Alloy 6063-T832.
- D. Plate and Sheet: **ASTM B209 (ASTM B209M)**, Alloy 6061-T6.

**Okaloosa County TDC – Destin Fort Walton Beach Convention Center
Exterior Accessibility**

- E. Die and Hand Forgings: **ASTM B247 (ASTM B247M)**, Alloy 6061-T6.
- F. Castings: ASTM B26/B26M, Alloy A356.0-T6.

2.4 FASTENERS

- A. Fastener Materials:
 - 1. Aluminum Railing Components: Type 316 stainless steel fasteners.
- B. Post-Installed Anchors: Fastener systems with working capacity greater than or equal to the design load, according to an evaluation report acceptable to authorities having jurisdiction, based on ICC-ES AC193.
 - 1. Material for Exterior Locations and Where Stainless Steel Is Indicated: Alloy Group **1 (A1)** stainless steel bolts, ASTM F593, and nuts, ASTM F594.

2.5 MISCELLANEOUS MATERIALS

- A. Handrail Brackets: Cast aluminum, center of handrail **2-1/2 inches (63.5 mm)** from face of wall.
- B. Welding Rods and Bare Electrodes: Select in accordance with AWS specifications for metal alloy welded.
 - 1. For aluminum railings, provide type and alloy as recommended by producer of metal to be welded and as required for color match, strength, and compatibility in fabricated items.
- C. Bituminous Paint: Cold-applied asphalt emulsion, complying with ASTM D1187/D1187M.
- D. Nonshrink, Nonmetallic Grout: Factory-packaged, nonstaining, noncorrosive, nongaseous grout, complying with ASTM C1107/C1107M. Provide grout specifically recommended by manufacturer for interior and exterior applications.
- E. Anchoring Cement: Factory-packaged, nonshrink, nonstaining, hydraulic-controlled expansion cement formulation for mixing with water at Project site to create pourable anchoring, patching, and grouting compound.
 - 1. Water-Resistant Product: At exterior locations, provide formulation that is resistant to erosion from water exposure without needing protection by a sealer or waterproof coating and that is recommended by manufacturer for exterior use.

2.6 FABRICATION

- A. Cut, drill, and punch metals cleanly and accurately.
 - 1. Remove burrs and ease edges to a radius of approximately **1/32 inch (1 mm)** unless otherwise indicated.

**Okaloosa County TDC – Destin Fort Walton Beach Convention Center
Exterior Accessibility**

2. Remove sharp or rough areas on exposed surfaces.
- B. Form work true to line and level with accurate angles and surfaces.
 - C. Welded Connections for Aluminum Pipe: Fabricate railings to interconnect members with concealed internal welds that eliminate surface grinding, using manufacturer's standard system of sleeve and socket fittings.
 - D. Nonwelded Connections: Connect members with concealed mechanical fasteners and fittings. Fabricate members and fittings to produce flush, smooth, rigid, hairline joints.
 - E. Bend members in jigs to produce uniform curvature for each configuration required. Maintain cross section of member throughout entire bend without buckling, twisting, cracking, or otherwise deforming exposed surfaces of components.
 - F. Close exposed ends of hollow railing members with prefabricated cap and end fittings of same metal and finish as railings.
 - G. Provide wall returns at ends of wall-mounted handrails unless otherwise indicated. Close ends of returns unless clearance between end of rail and wall is **1/4 inch (6 mm)** or less.
 - H. Brackets, Flanges, Fittings, and Anchors: Provide wall brackets, flanges, miscellaneous fittings, and anchors to interconnect railing members to other work unless otherwise indicated.
 1. At brackets and fittings fastened to plaster or gypsum board partitions, provide crush-resistant fillers or other means to transfer loads through wall finishes to structural supports and prevent bracket or fitting rotation and crushing of substrate.
 - I. Provide inserts and other anchorage devices for connecting railings to concrete or masonry work.
 1. Fabricate anchorage devices capable of withstanding loads imposed by railings.
 2. Coordinate anchorage devices with supporting structure.
 - J. For railing posts set in concrete, provide stainless steel sleeves not less than **6 inches (150 mm)** long with inside dimensions not less than **1/2 inch (13 mm)** greater than outside dimensions of post, with metal plate forming bottom closure.
- 2.7 ALUMINUM FINISHES
- A. Appearance of Finished Work: Variations in appearance of abutting or adjacent pieces are acceptable if they are within one-half of the range of approved Samples. Noticeable variations in the same piece are unacceptable. Variations in appearance of other components are acceptable if they are within the range of approved Samples and are assembled or installed to minimize contrast.
 - B. Mill Finish: AA-M12, nonspecular as fabricated.

**Okaloosa County TDC – Destin Fort Walton Beach Convention Center
Exterior Accessibility**

PART 3 - EXECUTION

3.1 INSTALLATION, GENERAL

- A. Perform cutting, drilling, and fitting required for installing railings.
1. Fit exposed connections together to form tight, hairline joints.
 2. Install railings level, plumb, square, true to line; without distortion, warp, or rack.
 3. Set railings accurately in location, alignment, and elevation; measured from established lines and levels.
 4. Do not weld, cut, or abrade surfaces of railing components that are coated or finished after fabrication and that are intended for field connection by mechanical or other means without further cutting or fitting.
 5. Set posts plumb within a tolerance of **1/16 inch in 3 feet (2 mm in 1 m)**.
 6. Align rails so variations from level for horizontal members and variations from parallel with rake of steps and ramps for sloping members do not exceed **1/4 inch in 12 feet (6 mm in 3.5 m)**.
- B. Control of Corrosion: Prevent galvanic action and other forms of corrosion by insulating metals and other materials from direct contact with incompatible materials.
1. Coat concealed surfaces of aluminum that will be in contact with grout, concrete, masonry, wood, or dissimilar metals, with a heavy coat of bituminous paint.

3.2 ANCHORING POSTS

- A. Use stainless steel pipe sleeves preset and anchored into concrete for installing posts. After posts are inserted into sleeves, fill annular space between post and sleeve with nonshrink, nonmetallic grout or anchoring cement, mixed and placed to comply with anchoring material manufacturer's written instructions.
- B. Form or core-drill holes not less than **5 inches (125 mm)** deep and **3/4 inch (20 mm)** larger than OD of post for installing posts in concrete. Clean holes of loose material, insert posts, and fill annular space between post and concrete with nonshrink, nonmetallic grout or anchoring cement mixed and placed to comply with anchoring material manufacturer's written instructions.
- C. Anchor posts to metal surfaces with flanges, angle type, or floor type, as required by conditions, connected to posts and to metal supporting members as follows:

3.3 ATTACHING RAILINGS

- A. Attach handrails to walls with wall brackets, except where end flanges are used. Provide brackets with **1-1/2-inch (38-mm)** clearance from inside face of handrail and finished wall surface.

**Okaloosa County TDC – Destin Fort Walton Beach Convention Center
Exterior Accessibility**

- B. Secure wall brackets and railing end flanges to building construction as follows:
1. For concrete and solid masonry anchorage, use drilled-in expansion shields and hanger or lag bolts.
 2. For hollow masonry anchorage, use toggle bolts.
 3. For wood stud partitions, use hanger or lag bolts set into studs or wood backing between studs. Coordinate with carpentry work to locate backing members.
 4. For steel-framed partitions, use hanger or lag bolts set wood backing between studs. Coordinate with stud installation to locate backing members.
 5. For steel-framed partitions, fasten brackets directly to steel framing or concealed steel reinforcements, using self-tapping screws of size and type required to support structural loads.
 6. For steel-framed partitions, use toggle bolts installed through flanges of steel framing or through concealed steel reinforcements.

3.4 CLEANING

- A. Clean aluminum by washing thoroughly with clean water and soap and rinsing with clean water.

PART 4 - SCHEDULE

4.1 HANDRAILS AND GUARDRAILS

- A. Handrails, posts, top and bottom guard rails to be 1-5/8" O.D.
- B. Intermediate pickets to be 1" O.D.
- C. Top of guardrails to be 42" AFF
- D. Bottom of guardrails to be 4" AFF
- E. Handrails to be 36" AFF
- F. Intermediate pickets to be spaced at 4" O.C.
- G. Comply with requirements prescribed in Florida Building Code Sections 1012 & 1013.

END OF SECTION 055213

**Okaloosa County TDC – Destin Fort Walton Beach Convention Center
Exterior Accessibility**

SECTION 072100 - THERMAL INSULATION

PART 1 - GENERAL

1.1 SUMMARY

- A. Section Includes:
 - 1. Glass-fiber blanket.

1.2 ACTION SUBMITTALS

- A. Product Data: For each type of product.
- B. Low-emitting product certification.

1.3 INFORMATIONAL SUBMITTALS

- A. Product test reports.
- B. Research reports.

PART 2 - PRODUCTS

2.1 GLASS-FIBER BLANKET

- A. Sustainability Requirements: Provide glass-fiber blanket insulation as follows:
 - 1. Free of Formaldehyde: Insulation manufactured with 100 percent acrylic binders and no formaldehyde.
 - 2. Low Emitting: Insulation tested according to ASTM D 5116 and shown to emit less than 0.05-ppm formaldehyde.
 - 3. Low Emitting: Complies with the testing and product requirements of the California Department of Public Health's (formerly, the California Department of Health Services') "Standard Method for the Testing and Evaluation of Volatile Organic Chemical Emissions from Indoor Sources Using Environmental Chambers."
- B. Glass-Fiber Blanket, Unfaced: ASTM C 665, Type I; with maximum flame-spread and smoke-developed indexes of 25 and 50, respectively, per ASTM E 84; passing ASTM E 136 for combustion characteristics.

2.2 ACCESSORIES

- A. Insulation for Miscellaneous Voids:

**Okaloosa County TDC – Destin Fort Walton Beach Convention Center
Exterior Accessibility**

- B. Insulation Anchors, Spindles, and Standoffs: To prevent sagging and movement as recommended by manufacturer.

PART 3 - EXECUTION

3.1 INSTALLATION, GENERAL

- A. Comply with insulation manufacturer's written instructions applicable to products and applications.
- B. Install insulation that is undamaged, dry, and unsoiled and that has not been left exposed to ice, rain, or snow at any time.
- C. Extend insulation to envelop entire area to be insulated. Fit tightly around obstructions and fill voids with insulation. Remove projections that interfere with placement.
- D. Provide sizes to fit applications and selected from manufacturer's standard thicknesses, widths, and lengths. Apply single layer of insulation units unless multiple layers are otherwise shown or required to make up total thickness or to achieve R-value.
- E. Install sound batting insulation as shown on drawings

3.2 INSTALLATION OF INSULATION IN FRAMED CONSTRUCTION

- A. Blanket Insulation: Install in cavities formed by framing members according to the following requirements:
 - 1. Use insulation widths and lengths that fill the cavities formed by framing members. If more than one length is required to fill the cavities, provide lengths that will produce a snug fit between ends.
 - 2. Place insulation in cavities formed by framing members to produce a friction fit between edges of insulation and adjoining framing members.
 - 3. Maintain 3-inch (76-mm) clearance of insulation around recessed lighting fixtures not rated for or protected from contact with insulation.
 - 4. For metal-framed wall cavities where cavity heights exceed 96 inches (2438 mm), support unfaced blankets mechanically.
- B. Miscellaneous Voids: Install insulation in miscellaneous voids and cavity spaces where required to prevent gaps in insulation using the following materials:
 - 1. Glass-Fiber Insulation: Compact to approximately 40 percent of normal maximum volume equaling a density of approximately 2.5 lb/cu. ft. (40 kg/cu. m).

END OF SECTION 072100

**Okaloosa County TDC – Destin Fort Walton Beach Convention Center
Exterior Accessibility**

SECTION 079200 - JOINT SEALANTS

PART 1 - GENERAL

1.1 SUMMARY

A. Section Includes:

1. Silicone joint sealants.
2. Nonstaining silicone joint sealants.
3. Mildew-resistant joint sealants.

1.2 PREINSTALLATION MEETINGS

- A. Preinstallation Conference: Conduct conference at Project site.

1.3 ACTION SUBMITTALS

- A. Product Data: For each joint-sealant product.
- B. Samples: For each kind and color of joint sealant required.
- C. Joint-Sealant Schedule: Include the following information:
1. Joint-sealant application, joint location, and designation.
 2. Joint-sealant manufacturer and product name.
 3. Joint-sealant formulation.
 4. Joint-sealant color.

1.4 INFORMATIONAL SUBMITTALS

- A. Product test reports.
- B. Preconstruction laboratory test reports.
- C. Preconstruction field-adhesion-test reports.
- D. Field-adhesion-test reports.
- E. Sample warranties.

**Okaloosa County TDC – Destin Fort Walton Beach Convention Center
Exterior Accessibility**

1.5 QUALITY ASSURANCE

- A. Testing Agency Qualifications: Qualified according to ASTM C1021 to conduct the testing indicated.

1.6 PRECONSTRUCTION TESTING

- A. Preconstruction Laboratory Testing: Submit to joint-sealant manufacturers, for testing indicated below, samples of materials that will contact or affect joint sealants.
 - 1. Adhesion Testing: Use ASTM C794 to determine whether priming and other specific joint preparation techniques are required to obtain rapid, optimum adhesion of joint sealants to joint substrates.
 - 2. Compatibility Testing: Use ASTM C1087 to determine sealant compatibility when in contact with glazing and gasket materials.
- B. Preconstruction Field-Adhesion Testing: Before installing sealants, field test their adhesion to Project joint substrates. Test joint sealants according to Method A, Field-Applied Sealant Joint Hand Pull Tab, in Appendix X1.1 in ASTM C1193 or Method A, Tail Procedure, in ASTM C1521.

1.7 WARRANTY

- A. Special Installer's Warranty: Installer agrees to repair or replace joint sealants that do not comply with performance and other requirements specified in this Section within specified warranty period.
 - 1. Warranty Period: Two years from date of Substantial Completion.
- B. Special Manufacturer's Warranty: Manufacturer agrees to furnish joint sealants to repair or replace those joint sealants that do not comply with performance and other requirements specified in this Section within specified warranty period.
 - 1. Warranty Period: Five years from date of Substantial Completion.

PART 2 - PRODUCTS

2.1 JOINT SEALANTS, GENERAL

- A. Colors of Exposed Joint Sealants: As selected by Architect from manufacturer's full range.

**Okaloosa County TDC – Destin Fort Walton Beach Convention Center
Exterior Accessibility**

2.2 SILICONE JOINT SEALANTS

- A. Silicone, S, NS, 100/50, NT: Single-component, nonsag, plus 100 percent and minus 50 percent movement capability, nontraffic-use, neutral-curing silicone joint sealant; ASTM C920, Type S, Grade NS, Class 100/50, Use NT.

2.3 NONSTAINING SILICONE JOINT SEALANTS

- A. Nonstaining Joint Sealants: No staining of substrates when tested according to ASTM C1248.
- B. Silicone, Nonstaining, S, NS, 100/50, NT: Nonstaining, single-component, nonsag, plus 100 percent and minus 50 percent movement capability, nontraffic-use, neutral-curing silicone joint sealant; ASTM C920, Type S, Grade NS, Class 100/50, Use NT.

2.4 MILDEW-RESISTANT JOINT SEALANTS

- A. Mildew-Resistant Joint Sealants: Formulated for prolonged exposure to humidity with fungicide to prevent mold and mildew growth.
- B. Silicone, Mildew Resistant, Acid Curing, S, NS, 25, NT: Mildew-resistant, single-component, nonsag, plus 25 percent and minus 25 percent movement capability, nontraffic-use, acid-curing silicone joint sealant; ASTM C920, Type S, Grade NS, Class 25, Use NT.
- C. Acrylic Latex: Acrylic latex or siliconized acrylic latex, ASTM C834, Type OP, Grade NF.

2.5 MISCELLANEOUS MATERIALS

- A. Primer: Material recommended by joint-sealant manufacturer where required for adhesion of sealant to joint substrates indicated, as determined from preconstruction joint-sealant-substrate tests and field tests.
- B. Cleaners for Nonporous Surfaces: Chemical cleaners acceptable to manufacturers of sealants and sealant backing materials.
- C. Masking Tape: Nonstaining, nonabsorbent material compatible with joint sealants and surfaces adjacent to joints.

PART 3 - EXECUTION

3.1 PREPARATION

- A. Surface Cleaning of Joints: Clean out joints immediately before installing joint sealants to comply with joint-sealant manufacturer's written instructions and the following requirements:
 - 1. Remove laitance and form-release agents from concrete.

**Okaloosa County TDC – Destin Fort Walton Beach Convention Center
Exterior Accessibility**

2. Clean nonporous joint substrate surfaces with chemical cleaners or other means that do not stain, harm substrates, or leave residues capable of interfering with adhesion.
- B. Joint Priming: Prime joint substrates where recommended by joint-sealant manufacturer or as indicated by preconstruction joint-sealant-substrate tests or prior experience.
- C. Masking Tape: Use masking tape where required to prevent contact of sealant or primer with adjoining surfaces.

3.2 INSTALLATION OF JOINT SEALANTS

- A. General: Comply with ASTM C1193 and joint-sealant manufacturer's written installation instructions for products and applications indicated, unless more stringent requirements apply.
- B. Install sealant backings of kind indicated to support sealants during application and at position required to produce cross-sectional shapes and depths of installed sealants relative to joint widths that allow optimum sealant movement capability.
- C. Install bond-breaker tape behind sealants where sealant backings are not used between sealants and backs of joints.
- D. Install sealants using proven techniques that comply with the following and at the same time backings are installed:
 1. Place sealants so they directly contact and fully wet joint substrates.
 2. Completely fill recesses in each joint configuration.
 3. Produce uniform, cross-sectional shapes and depths relative to joint widths that allow optimum sealant movement capability.
- E. Tooling of Nonsag Sealants: Immediately after sealant application and before skinning or curing begins, tool sealants to form smooth, uniform beads of configuration indicated. Use tooling agents that are approved in writing by sealant manufacturer and that do not discolor sealants or adjacent surfaces.
 1. Provide concave joint profile per Figure 8A in ASTM C1193 unless otherwise indicated.

3.3 FIELD QUALITY CONTROL

- A. Field-Adhesion Testing: Field test joint-sealant adhesion to joint substrates as follows:
 1. Extent of Testing: Test completed and cured sealant joints as follows:
 - a. Perform one test for each 50 feet of joint length.
 2. Test Method: Test joint sealants according to Method A, Field-Applied Sealant Joint Hand Pull Tab, in Appendix X1 in ASTM C1193 or Method A, Tail Procedure, in ASTM C1521.

**Okaloosa County TDC – Destin Fort Walton Beach Convention Center
Exterior Accessibility**

- B. Evaluation of Field-Adhesion-Test Results: Sealants not evidencing adhesive failure from testing or noncompliance with other indicated requirements will be considered satisfactory. Remove sealants that fail to adhere to joint substrates during testing or to comply with other requirements. Retest failed applications until test results prove sealants comply with indicated requirements.

3.4 JOINT-SEALANT SCHEDULE

- A. Joint-Sealant Application: Interior joints in vertical surfaces and horizontal nontraffic surfaces].
 - 1. Joint Locations:
 - a. Control and expansion joints on exposed interior surfaces of walls.
 - b. Tile control and expansion joints.
 - c. Vertical joints on exposed surfaces of walls and partitions.
 - d. Other joints as indicated on Drawings.
 - 2. Joint-Sealant Color: As selected by Architect from manufacturer's full range of colors.

- B. Joint-Sealant Application: Mildew-resistant interior joints in vertical surfaces and horizontal nontraffic surfaces.
 - 1. Joint Locations:
 - a. Joints between plumbing fixtures and adjoining walls, floors, and counters.
 - b. Tile control and expansion joints where indicated.
 - c. Other joints as indicated on Drawings.
 - 2. Joint-Sealant Color: As selected by Architect from manufacturer's full range of colors.

END OF SECTION 079200

**Okaloosa County TDC – Destin Fort Walton Beach Convention Center
Exterior Accessibility**

Page Left Blank

**Okaloosa County TDC – Destin Fort Walton Beach Convention Center
Exterior Accessibility**

SECTION 081113 - HOLLOW METAL DOORS AND FRAMES

PART 1 - GENERAL

1.1 RELATED DOCUMENTS

- A. Drawings and general provisions of the Contract, including General and Supplementary Conditions and Division 01 Specification Sections, apply to this Section.

1.2 SUMMARY

- A. Section includes:
 - 1. Interior standard steel doors and frames.

1.3 ACTION SUBMITTALS

- A. Product Data: For each type of product.
- B. Shop Drawings: Include the following:
 - 1. Elevations of each door type.
 - 2. Details of doors, including vertical- and horizontal-edge details and metal thicknesses.
 - 3. Frame details for each frame type, including dimensioned profiles and metal thicknesses.
- C. Product Schedule: For hollow-metal doors and frames, prepared by or under the supervision of supplier, using same reference numbers for details and openings as those on Drawings. Coordinate with final door hardware schedule.

1.4 INFORMATIONAL SUBMITTALS

- A. Product test reports.
- B. Field quality control reports.

1.5 CLOSEOUT SUBMITTALS

- A. Record Documents: For fire-rated doors, list of door numbers and applicable room name and number to which door accesses.

**Okaloosa County TDC – Destin Fort Walton Beach Convention Center
Exterior Accessibility**

PART 2 - PRODUCTS**2.1 PERFORMANCE REQUIREMENTS**

- A. Fire-Rated Door Assemblies: Assemblies complying with NFPA 80 that are listed and labeled by a qualified testing agency acceptable to authorities having jurisdiction for fire-protection ratings and temperature-rise limits indicated on Drawings, based on testing at positive pressure according to NFPA 252 or UL 10C.
1. Smoke- and Draft-Control Door Assemblies: Listed and labeled for smoke and draft control by a qualified testing agency acceptable to authorities having jurisdiction, based on testing according to UL 1784 and installed in compliance with NFPA 105.
 2. Temperature-Rise Limit: Where indicated on Drawings, provide doors that have a maximum transmitted temperature end point of not more than **450 deg F (250 deg C)** above ambient after 30 minutes of standard fire-test exposure.

2.2 INTERIOR STANDARD STEEL DOORS AND FRAMES

- A. Construct hollow-metal doors and frames to comply with standards indicated for materials, fabrication, hardware locations, hardware reinforcement, tolerances, and clearances, and as specified.
- B. Standard-Duty Doors and Frames: ANSI/SDI A250.8, Level 1; ANSI/SDI A250.4, Level C.
1. Doors:
 - a. Type: Dutch Door.
 - b. Thickness: **1-3/4 inches (44.5 mm)**
 - c. Face: Uncoated steel sheet, minimum thickness of **0.032 inch (0.8 mm)**.
 - d. Edge Construction: Model 1, Full Flush.
 - e. Double Shelf, Stainless Steel, 12 inches (similar to Karpen Steel CUDM0003)
 - f. Fire-Rated Core: Manufacturer's standard core for fire-rated and temperature-rise-rated doors.
 2. Frames:
 - a. Materials: Uncoated steel sheet, minimum thickness of **0.042 inch (1.0 mm)**.
 - b. Construction: Face welded.

2.3 FRAME ANCHORS

- A. Jamb Anchors:
1. Type: Anchors of minimum size and type required by applicable door and frame standard, and suitable for performance level indicated.

**Okaloosa County TDC – Destin Fort Walton Beach Convention Center
Exterior Accessibility**

2. Quantity: Minimum of four anchors per jamb, with one additional anchor for frames with no floor anchor. Provide one additional anchor for each **24 inches (610 mm)** of frame height above **7 feet (2.1 m)**.
 3. Postinstalled Expansion Anchor: Minimum **3/8-inch- (9.5-mm-)** diameter bolts with expansion shields or inserts, with manufacturer's standard pipe spacer.
- B. Floor Anchors: Provide floor anchors for each jamb and mullion that extends to floor.
- C. Floor Anchors for Concrete Slabs with Underlayment: Adjustable-type anchors with extension clips, allowing not less than **2-inch (51-mm)** height adjustment. Terminate bottom of frames at top of underlayment.
- D. Material: ASTM A879/A879M, Commercial Steel (CS), **04Z (12G)** coating designation; mill phosphatized.
1. For anchors built into exterior walls, steel sheet complying with ASTM A1008/A1008M or ASTM A1011/A1011M; hot-dip galvanized according to ASTM A153/A153M, Class B.

2.4 MATERIALS

- A. Cold-Rolled Steel Sheet: ASTM A1008/A1008M, Commercial Steel (CS), Type B; suitable for exposed applications.
- B. Hot-Rolled Steel Sheet: ASTM A1011/A1011M, Commercial Steel (CS), Type B; free of scale, pitting, or surface defects; pickled and oiled.
- C. Metallic-Coated Steel Sheet: ASTM A653/A653M, Commercial Steel (CS), Type B.
- D. Inserts, Bolts, and Fasteners: Hot-dip galvanized according to ASTM A153/A153M.
- E. Power-Actuated Fasteners in Concrete: Fastener system of type suitable for application indicated, fabricated from corrosion-resistant materials, with clips or other accessory devices for attaching hollow-metal frames of type indicated.
- F. Mineral-Fiber Insulation: ASTM C665, Type I (blankets without membrane facing); consisting of fibers manufactured from slag or rock wool; with maximum flame-spread and smoke-developed indexes of 25 and 50, respectively; passing ASTM E136 for combustion characteristics.

2.5 FABRICATION

- A. Door Astragals: Provide overlapping astragal on one leaf of dutch door where required by NFPA 80 for fire-performance rating or where indicated. Extend minimum **3/4 inch (19 mm)** beyond edge of door on which astragal is mounted or as required to comply with published listing of qualified testing agency.

**Okaloosa County TDC – Destin Fort Walton Beach Convention Center
Exterior Accessibility**

- B. Hollow-Metal Frames: Fabricate in one piece except where handling and shipping limitations require multiple sections. Where frames are fabricated in sections, provide alignment plates or angles at each joint, fabricated of metal of same or greater thickness as frames.
 - 1. Provide countersunk, flat- or oval-head exposed screws and bolts for exposed fasteners unless otherwise indicated.
- C. Hardware Preparation: Factory prepare hollow-metal doors and frames to receive templated mortised hardware, and electrical wiring; include cutouts, reinforcement, mortising, drilling, and tapping according to ANSI/SDI A250.6, the Door Hardware Schedule, and templates.
 - 1. Reinforce doors and frames to receive nontemplated, mortised, and surface-mounted door hardware.
 - 2. Comply with BHMA A156.115 for preparing hollow-metal doors and frames for hardware.

2.6 STEEL FINISHES

- A. Prime Finish: Clean, pretreat, and apply manufacturer's standard primer.
 - 1. Shop Primer: Manufacturer's standard, fast-curing, lead- and chromate-free primer complying with ANSI/SDI A250.10; recommended by primer manufacturer for substrate; compatible with substrate and field-applied coatings despite prolonged exposure.

PART 3 - EXECUTION

3.1 PREPARATION

- A. Remove welded-in shipping spreaders installed at factory. Restore exposed finish by grinding, filling, and dressing, as required to make repaired area smooth, flush, and invisible on exposed faces. Touch up factory-applied finishes where spreaders are removed.
- B. Drill and tap doors and frames to receive nontemplated, mortised, and surface-mounted door hardware.

3.2 INSTALLATION

- A. Hollow-Metal Frames: Comply with ANSI/SDI A250.11.
 - 1. Set frames accurately in position; plumbed, aligned, and braced securely until permanent anchors are set. After wall construction is complete, remove temporary braces without damage to completed Work.
 - a. Where frames are fabricated in sections, field splice at approved locations by welding face joint continuously; grind, fill, dress, and make splice smooth, flush, and invisible on exposed faces. Touch-up finishes.

**Okaloosa County TDC – Destin Fort Walton Beach Convention Center
Exterior Accessibility**

- b. Install frames with removable stops located on secure side of opening.
 2. Fire-Rated Openings: Install frames according to NFPA 80.
 3. Floor Anchors: Secure with postinstalled expansion anchors.
 - a. Floor anchors may be set with power-actuated fasteners instead of postinstalled expansion anchors if so indicated and approved on Shop Drawings.
 4. Solidly pack mineral-fiber insulation inside frames.
 5. Masonry Walls: Coordinate installation of frames to allow for solidly filling space between frames and masonry with grout or mortar.
 6. In-Place Concrete or Masonry Construction: Secure frames in place with postinstalled expansion anchors. Countersink anchors, and fill and make smooth, flush, and invisible on exposed faces.
 7. Installation Tolerances: Adjust hollow-metal frames to the following tolerances:
 - a. Squareness: Plus or minus **1/16 inch (1.6 mm)**, measured at door rabbet on a line 90 degrees from jamb perpendicular to frame head.
 - b. Alignment: Plus or minus **1/16 inch (1.6 mm)**, measured at jambs on a horizontal line parallel to plane of wall.
 - c. Twist: Plus or minus **1/16 inch (1.6 mm)**, measured at opposite face corners of jambs on parallel lines, and perpendicular to plane of wall.
 - d. Plumbness: Plus or minus **1/16 inch (1.6 mm)**, measured at jambs at floor.
- B. Hollow-Metal Doors: Fit and adjust hollow-metal doors accurately in frames, within clearances specified below.
1. Fire-Rated Doors: Install doors with clearances according to NFPA 80.
- 3.3 REPAIR
- A. Prime-Coat Touchup: Immediately after erection, sand smooth rusted or damaged areas of prime coat and apply touchup of compatible air-drying, rust-inhibitive primer.
 - B. Metallic-Coated Surface Touchup: Clean abraded areas and repair with galvanizing repair paint according to manufacturer's written instructions.
 - C. Touchup Painting: Cleaning and touchup painting of abraded areas of paint are specified in painting Sections.

END OF SECTION 081113

**Okaloosa County TDC – Destin Fort Walton Beach Convention Center
Exterior Accessibility**

Page left blank

**Okaloosa County TDC – Destin Fort Walton Beach Convention Center
Exterior Accessibility**

SECTION 083113 - ACCESS DOORS AND FRAMES

PART 1 - GENERAL

1.1 SUMMARY

A. Section Includes:

1. Access doors and frames for walls and ceilings.

1.2 ACTION SUBMITTALS

- A. Product Data: For each type of product.
- B. Shop Drawings: Include plans, elevations, sections, details, and attachments to other work.
- C. Samples: For each door face material.
- D. Schedule: Types, locations, sizes, latching or locking provisions, and other data pertinent to installation.

PART 2 - PRODUCTS

2.1 PERFORMANCE REQUIREMENTS

- A. Fire-Rated Access Doors and Frames: Units complying with NFPA 80 tested according to the following test method:
 1. NFPA 252 or UL 10B for fire-rated access door assemblies installed vertically.
 2. NFPA 288 for fire-rated access door assemblies installed horizontally.

2.2 ACCESS DOORS AND FRAMES FOR WALLS AND CEILINGS

- A. Manufacturers: Subject to compliance with requirements, available manufacturers offering products that may be incorporated into the Work include, but are not limited to, the following:
- B. Basis-of-Design Product: Subject to compliance with requirements, provide product indicated or comparable product by one of the following:
 1. Acudor Products, Inc.
 2. Activar, Inc.
 3. Larsen's Manufacturing Company.
 4. Milcor Inc.

**Okaloosa County TDC – Destin Fort Walton Beach Convention Center
Exterior Accessibility**

- C. Source Limitations: Obtain each type of access door and frame from single source from single manufacturer.
- D. Flush Access Doors with Exposed Flanges:
1. Basis-of-Design Product: Milcor Inc
 2. Assembly Description: Fabricate door to fit flush to frame. Provide manufacturer's standard-width exposed flange, proportional to door size.
 3. Locations: Wall.
 4. Uncoated Steel Sheet for Door: 16 gage.
 - a. Finish: Factory prime;
 5. Frame Material: Same material, thickness, and finish as door
 6. Hinges: Manufacturer's standard.
 7. Hardware: Latch.
- E. Flush Access Doors with Concealed Flanges:
1. Basis-of-Design Product: Milcor Inc.
 2. Assembly Description: Fabricate door to fit flush to frame. Provide frame with gypsum board beads for concealed flange installation.
 3. Locations: Ceiling.
 4. Uncoated Steel Sheet for Door: 16 gage
 - a. Finish: Factory prime.
 5. Frame Material: Same material and thickness as door.
 6. Hinges: Manufacturer's standard
 7. Hardware: Latch.
 8. Fire-Rated, Flush Access Doors with Exposed Flanges
- F. Flush Access Doors with Fire Rating
1. Basis-of-Design Product: Activar, Inc.
 2. Assembly Description: Fabricate door to fit flush to frame, with a core of mineral-fiber insulation enclosed in sheet metal. Provide self-latching door with automatic closer and interior latch release. Provide manufacturer's standard-width exposed flange, proportional to door size.
 3. Locations: Wall and ceiling.
 4. Fire-Resistance Rating: Not less than 1 hour or as scheduled.
 5. Temperature-Rise Rating: 450 deg F (250 deg C) at the end of 30 minutes'
 6. Uncoated Steel Sheet for Door: 20 gage.
 7. Finish: Factory prime.
 8. Frame Material: Same material, thickness, and finish as door.
 9. Hinges: Manufacturer's standard.
 10. Hardware: Latch.
 11. Latch: Cam

2.3 FINISHES

- A. Comply with NAAMM's "Metal Finishes Manual for Architectural and Metal Products" for recommendations for applying and designating finishes.

**Okaloosa County TDC – Destin Fort Walton Beach Convention Center
Exterior Accessibility**

- B. Protect mechanical finishes on exposed surfaces from damage by applying a strippable, temporary protective covering before shipping.
- C. Appearance of Finished Work: Noticeable variations in same piece are not acceptable. Variations in appearance of adjoining components are acceptable if they are within the range of approved Samples and are assembled or installed to minimize contrast.
- D. Steel and Metallic-Coated-Steel Finishes:
 - 1. Factory Prime: Apply manufacturer's standard, fast-curing, lead- and chromate-free, universal primer immediately after surface preparation and pretreatment.

PART 3 - EXECUTION

3.1 INSTALLATION

- A. Comply with manufacturer's written instructions for installing access doors and frames.
- B. Install doors flush with adjacent finish surfaces or recessed to receive finish material.

3.2 ADJUSTING

- A. Adjust doors and hardware, after installation, for proper operation.
- B. Remove and replace doors and frames that are warped, bowed, or otherwise damaged.

END OF SECTION 083113

**Okaloosa County TDC – Destin Fort Walton Beach Convention Center
Exterior Accessibility**

PAGE LEFT BLANK

**Okaloosa County TDC – Destin Fort Walton Beach Convention Center
Exterior Accessibility**

SECTION 084213 - ALUMINUM-FRAMED ENTRANCES

PART 1 - GENERAL

1.1 SUMMARY

A. Section Includes:

1. Swing entrance doors.

1.2 PREINSTALLATION MEETINGS

- A. Preinstallation Conference: Conduct conference at Project site.

1.3 ACTION SUBMITTALS

- A. Product Data: For each type of product.

- B. Shop Drawings: Include plans, elevations, sections, full-size details, and attachments to other work.

1. Show connection to and continuity with adjacent thermal, weather, air, and vapor barriers.
2. Include point-to-point wiring diagrams.

- C. Samples: For each type of exposed finish required.

- D. Entrance Door Hardware Schedule: Prepared by or under supervision of supplier, detailing fabrication and assembly of entrance door hardware, as well as procedures and diagrams.

1.4 INFORMATIONAL SUBMITTALS

- A. Energy Performance Certificates: NFRC-certified energy performance values from manufacturer.

- B. Product test reports.

- C. Field quality-control reports.

- D. Sample warranties.

**Okaloosa County TDC – Destin Fort Walton Beach Convention Center
Exterior Accessibility**

1.5 CLOSEOUT SUBMITTALS

- A. Maintenance data.

1.6 QUALITY ASSURANCE

- A. Installer Qualifications: An entity that employs installers and supervisors who are trained and approved by manufacturer.
- B. Testing Agency Qualifications: Qualified according to ASTM E699 for testing indicated.

1.7 WARRANTY

- A. Special Warranty: Installer agrees to repair or replace components of aluminum-framed entrances that do not comply with requirements or that fail in materials or workmanship within specified warranty period.
 - 1. Warranty Period: One year from date of Substantial Completion.
- B. Special Finish Warranty: Standard form in which manufacturer agrees to repair finishes or replace aluminum that shows evidence of deterioration of factory-applied finishes within specified warranty period.
 - 1. Warranty Period: One year from date of Substantial Completion.

PART 2 - PRODUCTS

2.1 MANUFACTURER

- A. YKK AP America Inc. 270 Riverside Pkwy, Suite 100, Austell, GA 30168

2.2 PERFORMANCE REQUIREMENTS

- A. Delegated Design: Engage a qualified professional engineer, as defined in Section 014000 "Quality Requirements," to design aluminum-framed entrances and storefronts. Design to incorporate and address the structural load requirements for the Sliding Automatic Doors.
- B. All unit sizes and configurations shall conform to the minimum sizes in accordance with; Florida High Velocity
- C. Hurricane Zone (HVHZ) Protocols, ASTM E 1886, ASTM E 1996, all requirements of TAS 201, TAS 202, and TAS 203. They shall also comply with the following specific performance requirements indicated.
 - 1. Air Infiltration (Single Acting Butt Hinges, Continuous Hinges, or Offset Pivots): Air infiltration shall be tested in accordance with ASTM E 283 at static pressure of 1.57 PSF

**Okaloosa County TDC – Destin Fort Walton Beach Convention Center
Exterior Accessibility**

- (75 Pa). Infiltration shall not exceed 0.50 CFM/FT² for single door or 1.00 CFM/FT² for pair doors.
2. Water Infiltration: No uncontrolled water other than condensation on indoor face of any component tested in accordance with ASTM E 331 at a test pressure differential of 10.5 psf (503 Pa). Water test to be performed immediately after design pressure test. Standard 50H Entrances are intended for 1st floor applications.
 3. Structural: Door corner structural strength shall be tested per YKK AP's dual moment test procedure and certified by an independent testing laboratory to ensure corner integrity and weld compliance. Certified test procedures and results are available upon request.
- D. Structural Uniform Load Test:
1. Doors:
 - a. Positive Pressure: 90 PSF – For Air Only Threshold.
 - b. 70 PSF – For Air and Water Threshold.
 - c. Negative Pressure: 90 PSF
- E. Forced Entry Resistance: Tests performed simultaneously with 300 lb. forces applied to the active door panel within 3" of the locks in the direction that would tend to open the door while 150 lb. forces are applied in both perpendicular directions to the 300 lb. force simultaneously.
- F. Forced Entry Resistance: Tests performed simultaneously with 300 lb. forces applied to the active door panel within 3" of the locks in the direction that would tend to open the door while 150 lb. forces are applied in both perpendicular directions to the 300 lb. force simultaneously.
- G. Acoustical Performance: Acoustical Performance: When tested in accordance with ASTM E 90, AAMA 1801:
1. Sound Transmission Class (STC) shall not be less than: 1" IGU; 32, laminated; 34.
 2. Outdoor-Indoor Transmission Class (OITC) shall not be less than: 1" IGU; 30, 1" laminated; 31.

2.3 ENTRANCE DOOR SYSTEMS

- A. Impact Resistant Entrances (to match existing door systems)
1. YKK AP Model 50H Impact Resistant Entrances.
 - a. 50H Description: 5" (127 mm) Door Stile, 2-3/8" thick.
 2. Corner Construction: Fabricate door corners joined by concealed reinforcement secured with screws and sigma deep penetration welding.
 3. Glazing: Manufacturer's standard glazing stops with EPDM glazing gaskets to prevent water infiltration at the exterior and structural silicone sealant for wet glazing, EPDM silicone compatible gasket for dry glazing with fixed stops at the interior.
 - a. Glazing to match existing door systems
 4. Weather-stripping: Manufacturer's standard elastomer type in replaceable rabbets for stiles and rails.

**Okaloosa County TDC – Destin Fort Walton Beach Convention Center
Exterior Accessibility**

2.4 MATERIALS

- A. Extrusions: ASTM B 221 (ASTM B 221M), 6063-T5 Aluminum Alloy.
- B. Aluminum Sheet:
 - 1. Anodized Finish: ASTM B 209 (ASTM B 209M), 5005-H14 Aluminum Alloy, 0.050" (1.27 mm) minimum thickness.
 - 2. Painted Finish: ASTM B 209 (ASTM B 209M), 3003-H14 Aluminum Alloy, 0.080" (1.95) mm) minimum thickness.

2.5 ACCESSORIES

- A. Manufacturer's Standard Accessories:
 - 1. Fasteners: Zinc plated steel concealed fasteners; Hardened aluminum alloys or AISI 300 series less steel exposed fasteners, countersunk, finish to match aluminum color.
 - 2. Perimeter Sealant: Non-skinning type, AAMA 803.3.
 - 3. Glazing: Setting blocks, edge blocks, and spacers in accordance with ASTM C 864, shore durometer hardness as recommended by manufacturer. Glazing gaskets in accordance with ASTM C 864.
 - 4. Glazing Adhesive: Dow Corning® 995 Structural Silicone Sealant.

2.6 FABRICATION

- A. Shop Assembly: Fabricate and assemble units with joints only at intersection of aluminum members with uniform hairline joints; rigidly secure, and sealed in accordance with manufacturer's recommendations.
 - 1. Hardware: Drill and cut to template for hardware. Reinforce frames and door stiles to receive hardware in accordance with manufacturer's recommendations.
 - 2. Welding: Conceal welds on aluminum members in accordance with AWS recommendations or methods recommended by manufacturer. Members showing welding bloom or discoloration on finish or material distortion will be rejected.

2.7 FINISHES AND COLORS

- A. YKK AP America Anodized Plus® Finish to match existing system

2.8 DOOR HARDWARE

- A. Match existing system and coordinate opening and access control hardware and equipment with existing access control system.

2.9 GLAZING

- A. Match existing system

**Okaloosa County TDC – Destin Fort Walton Beach Convention Center
Exterior Accessibility**

PART 3 - EXECUTION**3.1 INSTALLATION****A. General:**

1. Comply with manufacturer's written instructions.
2. Do not install damaged components.
3. Fit joints to produce hairline joints free of burrs and distortion.
4. Rigidly secure nonmovement joints.
5. Install anchors with separators and isolators to prevent metal corrosion and electrolytic deterioration and to prevent impeding movement of moving joints.
6. Seal perimeter and other joints watertight unless otherwise indicated.

B. Metal Protection:

1. Where aluminum is in contact with dissimilar metals, protect against galvanic action by painting contact surfaces with materials recommended by manufacturer for this purpose or installing nonconductive spacers.
2. Where aluminum is in contact with concrete or masonry, protect against corrosion by painting contact surfaces with bituminous paint.

C. Set continuous sill members and flashing in full sealant bed, as specified in Section 079200 "Joint Sealants," to produce weathertight installation.**D. Install components plumb and true in alignment with established lines and grades.****E. Entrance Doors: Install doors to produce smooth operation and tight fit at contact points.**

1. Install to produce weathertight enclosure and tight fit at weather stripping.
2. Field-Installed Entrance Door Hardware: Install surface-mounted entrance door hardware according to entrance door hardware manufacturers' written instructions using concealed fasteners to greatest extent possible.

3.2 FIELD QUALITY CONTROL**A. Field Quality-Control Testing: Perform the following test on aluminum-framed entrances.**

1. Water-Spray Test: Before installation of interior finishes has begun, areas designated by Architect shall be tested according to AAMA 501.2 and shall not evidence water penetration.
2. Air Infiltration: ASTM E783 at 1.5 times the rate specified for laboratory testing in "Performance Requirements" Article but not more than 0.09 cfm/sq. ft. (0.45 L/s per sq. m) at a static-air-pressure differential of 1.57 lbf/sq. ft. (75 Pa).
3. Water Penetration: ASTM E1105 at a minimum uniform and cyclic static-air-pressure differential of 0.67 times the static-air-pressure differential specified for laboratory

**Okaloosa County TDC – Destin Fort Walton Beach Convention Center
Exterior Accessibility**

testing in "Performance Requirements" Article, but not less than 6.24 lbf/sq. ft. (300 Pa), and shall not evidence water penetration.

- B. Aluminum-framed entrances will be considered defective if they do not pass tests and inspections.
- C. Prepare test and inspection reports.

3.3 ADJUSTING AND CLEANING

- A. Adjusting: Adjust swing doors for operation in accordance with manufacturer's recommendations.
- B. Cleaning: The Contractor shall clean installed products in accordance with manufacturer's instructions prior to owner's acceptance and remove construction debris from project site. Legally dispose of debris.
- C. Protection: The Contractor shall protect the installed product's finish surfaces from damage during construction.

3.4 ALUMINUM DOOR OPENING SCHEDULE

- A. Wind and Impact Resistant New Doors, frames, lites and related hardware:
 - 1. Doors 002A, 002B
- B. Non-Wind Resistant New Doors, frames, lites and related hardware:
 - 1. Doors 003A, 003B

3.5 ALUMINUM STOREFRONT SCHEDULE

- A. Wind and Impact Resistant, frames and lites:
 - 1. SF1, SF2, SF3
- B. Non-Wind Resistant, frames and lites:
 - 1. SF4

END OF SECTION 084213

**Okaloosa County TDC – Destin Fort Walton Beach Convention Center
Exterior Accessibility**

SECTION 084229 - SLIDING AUTOMATIC ENTRANCES

PART 1 - GENERAL

1.1 SUMMARY

- A. Section includes exterior and interior, sliding, power-operated automatic entrances.

1.2 PREINSTALLATION MEETINGS

- A. Preinstallation Conference: Conduct conference at Project site.

1.3 ACTION SUBMITTALS

- A. Product Data: For each type of product.
- B. Shop Drawings: For sliding automatic entrances.
 - 1. Include plans, elevations, sections, hardware mounting heights, and attachment details.
 - 2. Include diagrams for power, signal, and control wiring.
 - 3. Indicate locations of activation and safety devices.
 - 4. Include hardware schedule and indicate hardware types, functions, quantities, and locations.
- C. Samples: For each type of exposed finish required.
- D. Delegated-Design Submittal: For automatic entrances.

1.4 INFORMATIONAL SUBMITTALS

- A. Product certificates.
- B. Product test reports.
- C. Field quality-control reports.
- D. Sample warranties.

1.5 CLOSEOUT SUBMITTALS

- A. Operation and maintenance data.

**Okaloosa County TDC – Destin Fort Walton Beach Convention Center
Exterior Accessibility**

1.6 QUALITY ASSURANCE

- A. Installer Qualifications: Manufacturer's authorized representative who is trained and approved for installation and maintenance of units required for this Project.
- B. Certified Inspector Qualifications: Certified by AAADM.

1.7 WARRANTY

- A. Special Warranty: Manufacturer agrees to repair or replace components of automatic entrances that fail in materials or workmanship within specified warranty period.
 - 1. Warranty Period: Two years from date of Substantial Completion.
- B. Special Finish Warranty: Manufacturer agrees to repair or replace components on which finishes fail in materials or workmanship within specified warranty period.
 - 1. Deterioration includes, but is not limited to, the following:
 - a. Color fading more than 5 Hunter units when tested according to ASTM D2244.
 - b. Chalking in excess of a No. 8 rating when tested according to ASTM D4214.
 - c. Cracking, checking, peeling, or failure of paint to adhere to bare metal.
 - 2. Warranty Period: Five years from date of Substantial Completion.

PART 2 - PRODUCTS

2.1 AUTOMATIC ENTRANCE ASSEMBLIES

- A. Electrical Components, Devices, and Accessories: Listed and labeled as defined in NFPA 70, by a qualified testing agency, and marked for intended location and application.
- B. Power-Operated Door Standard: BHMA A156.10.

2.2 PERFORMANCE REQUIREMENTS

- A. Delegated Design: Engage a qualified professional engineer, as defined in Section 014000 "Quality Requirements," to design automatic entrances.
- B. Structural Performance: Automatic entrances shall withstand the effects of gravity loads and the following loads and stresses within limits and under conditions indicated according to ASCE/SEI 7.
 - 1. Hurricane Zone (HVHZ) Protocols, ASTM E 1886, ASTM E 1996, all requirements of TAS 201, TAS 202, and TAS 203. They shall also comply with the following specific performance requirements indicated.

**Okaloosa County TDC – Destin Fort Walton Beach Convention Center
Exterior Accessibility**

- a. Air Infiltration (Single Acting Butt Hinges, Continuous Hinges, or Offset Pivots): Air infiltration shall be tested in accordance with ASTM E 283 at static pressure of 1.57 PSF (75 Pa). Infiltration shall not exceed 0.50 CFM/FT² for single door or 1.00 CFM/FT² for pair doors.
 - b. Water Infiltration: No uncontrolled water other than condensation on indoor face of any component tested in accordance with ASTM E 331 at a test pressure differential of 10.5 psf (503 Pa). Water test to be performed immediately after design pressure test. Standard 50H Entrances are intended for 1st floor applications.
 - c. Structural: Door corner structural strength shall be tested per dual moment test procedure and certified by an independent testing laboratory to ensure corner integrity and weld compliance. Certified test procedures and results are available upon request.
2. Doors:
- a. Positive Pressure: 90 PSF – For Air Only Threshold.
 - b. 70 PSF – For Air and Water Threshold.
 - c. Negative Pressure: 90 PSF
- C. Forced Entry Resistance: Tests performed simultaneously with 300 lb. forces applied to the active door panel within 3" of the locks in the direction that would tend to open the door while 150 lb. forces are applied in both perpendicular directions to the 300 lb. force simultaneously.
- D. Forced Entry Resistance: Tests performed simultaneously with 300 lb. forces applied to the active door panel within 3" of the locks in the direction that would tend to open the door while 150 lb. forces are applied in both perpendicular directions to the 300 lb. force simultaneously.
- E. Acoustical Performance: Acoustical Performance: When tested in accordance with ASTM E 90, AAMA 1801:
1. Sound Transmission Class (STC) shall not be less than: 1" IGU; 32, laminated; 34.
 2. Outdoor-Indoor Transmission Class (OITC) shall not be less than: 1" IGU; 30, 1" laminated; 31.
- 2.3 SLIDING AUTOMATIC ENTRANCES
- A. General: Provide manufacturer's standard automatic entrances, including doors, framing, headers, carrier assemblies, roller tracks, door operators, controls, and accessories required for a complete installation.
- B. Automatic Entrance:
1. Biparting - Sliding Units:
 - a. DORMA – ESA 300 Automatic Sliding Glass Door – Large Missile Impact Resistant – Full Breakout
 - b. DORMA – ESA 300 Automatic Sliding Glass Door – Non-Impact Resistant – Full Breakout

**Okaloosa County TDC – Destin Fort Walton Beach Convention Center
Exterior Accessibility**

2. Configuration: Biparting-sliding doors with two sliding leaves and sidelites on each side.
 - a. Traffic Pattern: Two way.
 - b. Emergency Breakaway Capability: Sliding leaves and sidelites.
 - c. Mounting: Between jambs.
3. Operator Features:
 - a. Power opening and closing.
 - b. Drive System: Chain or belt.
 - c. Adjustable opening and closing speeds.
 - d. Adjustable hold-open time between zero and 30 seconds.
 - e. Obstruction recycle.
 - f. On-off/hold-open switch to control electric power to operator, key operated.
4. Sliding-Door Carrier Assemblies and Overhead Roller Tracks: Carrier assembly that allows vertical adjustment; consisting of nylon- or delrin-covered, ball-bearing-center steel wheels operating on a continuous roller track, or ball-bearing-center steel wheels operating on a nylon- or delrin-covered, continuous roller track. Support doors from carrier assembly by cantilever and pivot assembly.
 - a. Rollers: Minimum of two ball-bearing roller wheels and two antirise rollers for each active leaf.
5. Sliding-Door Threshold: Threshold members and bottom-guide-track system with stainless-steel, ball-bearing-center roller wheels.
 - a. Configuration: Saddle-type threshold across door opening and surface-mounted guide-track system at sidelites.
6. Controls: Activation and safety devices according to BHMA standards.
 - a. Activation Device: Motion sensor mounted on each side of door header to detect pedestrians in activating zone and to open door.
 - b. Safety Device: Presence sensor mounted to underside of door header and two photoelectric beams mounted in sidelite jambs on one side of the door to detect pedestrians in presence zone and to prevent door from closing.
7. Finish: Finish framing, door(s), and header with finish matching adjacent storefront.

2.4 ENTRANCE COMPONENTS

- A. Framing Members: Extruded aluminum, minimum **0.125 inch (3.2 mm)** thick and reinforced as required to support imposed loads.
 1. Extruded Glazing Stops and Applied Trim: Minimum **0.062-inch (1.6-mm)** wall thickness.

**Okaloosa County TDC – Destin Fort Walton Beach Convention Center
Exterior Accessibility**

- B. Stile and Rail Doors: **1-3/4-inch- (45-mm-)** thick, glazed doors with minimum **0.125-inch- (3.2-mm-)** thick, extruded-aluminum tubular stile and rail members. Mechanically fasten corners with reinforcing brackets that are welded, or incorporate concealed tie-rods that span full length of top and bottom rails.
 - 1. Glazing Stops and Gaskets: Snap-on, extruded-aluminum stops and preformed gaskets.
 - 2. Muntin Bars: Horizontal tubular rail member for each door; match stile design and finish.
- C. Sidelite(s) and Transom: **1-3/4-inch- (45-mm-)** deep sidelite(s) and transom with minimum **0.125-inch- (3.2-mm-)** thick, extruded-aluminum tubular stile and rail members matching door design.
 - 1. Glazing Stops and Gaskets: Same materials and design as for stile and rail door.
 - 2. Muntin Bars: Horizontal tubular rail members for each sidelite; match stile design.
- D. Headers and Jambs: Fabricated from minimum **0.125-inch- (3.2-mm-)** thick extruded aluminum and extending full width of automatic entrance units to conceal door operators, controls, and structural steel members, plates and fasteners. Provide hinged or removable access panels for service and adjustment of door operators and controls. Secure panels to prevent unauthorized access.
 - 1. Mounting: Concealed, with one side of header and jambs flush with framing.
- E. Signage: As required by cited BHMA standard.
 - 1. Application Process: Door manufacturer's standard process.

2.5 MATERIALS

- A. Aluminum: Alloy and temper recommended by manufacturer for type of use and finish indicated.
 - 1. Extrusions: **ASTM B221 (ASTM B221M)**.
 - 2. Sheet: **ASTM B209 (ASTM B209M)**.
- B. Steel Reinforcement: Reinforcement with corrosion-resistant primer complying with SSPC-PS Guide No. 12.00 applied immediately after surface preparation and pretreatment. Use surface preparation methods according to recommendations in SSPC-SP COM and prepare surfaces according to applicable SSPC standard.
- C. Glazing: Door manufacturer requirements to meet Large Missile Impact Resistant at exterior locations and Non-Impact Resistant at interior locations. Glazing to match adjacent storefront tints.
- D. Sealants and Joint Fillers: As specified in Section 079200 "Joint Sealants."
- E. Nonmetallic, Shrinkage-Resistant Grout: Premixed, nonmetallic, noncorrosive, nonstaining grout; complying with ASTM C1107/C1107M; of consistency suitable for application.

**Okaloosa County TDC – Destin Fort Walton Beach Convention Center
Exterior Accessibility**

- F. Bituminous Coating: Cold-applied asphalt emulsion complying with ASTM D1187/D1187M.
- G. Fasteners and Accessories: Corrosion-resistant, nonstaining, nonbleeding fasteners and accessories compatible with adjacent materials.

2.6 DOOR OPERATORS AND CONTROLS

- A. General: Provide operators and controls, which include activation and safety devices, according to BHMA standards, for condition of exposure, and for long-term, maintenance-free operation under normal traffic load for type of occupancy indicated.
- B. Door Operators: Provide door operators of size recommended by manufacturer for door size, weight, and movement.
 - 1. Door Operator Performance: Door operators shall open and close doors and maintain them in fully closed position when subjected to Project's design wind loads.
 - 2. Electromechanical Operators: Concealed, self-contained, overhead units powered by fractional-horsepower, permanent-magnet dc motor; with closing speed controlled mechanically by gear train and dynamically by braking action of electric motor; with solid-state microprocessor controller; complying with UL 325; and with manual operation with power off.
- C. Motion Sensors: Self-contained, K-band-frequency, microwave-scanner units; fully enclosed by their plastic housings; adjustable to provide detection-field sizes and functions required by BHMA A156.10.
 - 1. Provide capability for switching between bi- and unidirectional detection.
 - 2. For one-way traffic, sensor on egress side shall not be active when doors are fully closed.
- D. Presence Sensors: Self-contained, active-infrared scanner units; adjustable to provide detection-field sizes and functions required by BHMA A156.10. Sensors shall remain active at all times.
- E. Photoelectric Beams: Pulsed infrared, sender-receiver assembly for recessed mounting. Beams shall not be active when doors are fully closed.
- F. Push-Plate Switch: Momentary-contact door-control switch with flat push-plate actuator, with contrasting-colored, engraved message.
 - 1. Configuration: Square push plate with 4-by-4-inch (100-by-100-mm) junction box.
 - a. Mounting: Surface mounted on wall.
 - 2. Push-Plate Material: Stainless steel.
 - 3. Message: International symbol of accessibility and "Push to Open."
- G. Electrical Interlocks: Unless units are equipped with self-protecting devices or circuits, provide electrical interlocks to prevent activation of operator when door is locked, latched, or bolted.

**Okaloosa County TDC – Destin Fort Walton Beach Convention Center
Exterior Accessibility**

2.7 HARDWARE

- A. General: Provide units in sizes and types recommended by automatic entrance and hardware manufacturers for entrances and uses indicated. Finish exposed parts to match door finish unless otherwise indicated.
- B. Breakaway Device for Power-Operated Doors: Device that allows door to swing out in direction of egress to full 90 degrees from any operating position. Interrupt powered operation of door operator while in breakaway mode.
- C. Deadlocks: Deadbolt operated by exterior cylinder and interior thumb turn, with minimum **1-inch- (25-mm-)** long throw bolt; BHMA A156.5, Grade 1.
 - 1. Cylinders: BHMA A156.5, Grade 1, six-pin mortise type.
 - a. Keying: Integrate into building master key system.
 - b. Keys: Three for each cylinder.
 - 2. Deadbolts: Laminated-steel hook mortise type, BHMA A156.5, Grade 1.
 - 3. Two-Point Locking for Stile and Rail Sliding Doors: Mechanism in stile of active door leaf that automatically extends second lockbolt into overhead carrier assembly.
 - 4. Lock/Unlock Indicator: Lock position indicators integrated with locking system. Stile is mounted on secure side of door. Visual display of lock position as follows: "OPEN" in black letters when unlocked, and "LOCKED" in red letters when locked.
 - 5. Armored Strike: Reinforced security strike plate.
- D. Automatic Locking: Electrically controlled device mounted in header that automatically locks sliding door in closed position, preventing door panels from sliding manually. Provide fail- safe operation if power fails.
 - 1. Means of Egress: Standard breakaway feature.
- E. Access-Control Locking: Electrically controlled device mounted in header that automatically locks sliding door in closed position, preventing door panels from sliding manually. Provide fail- safe operation if power fails.
- F. Uninterrupted Power Supply: UL 1778, fully integrated unit mounted within header or above ceiling.
- G. Dustproof Strikes for All-Glass Sliding Doors: Recessed, floor type, BHMA A156.16, Grade 1, to receive deadbolt
- H. Weather Stripping: Replaceable components.
 - 1. Sliding Type: AAMA 701/702, made of wool, polypropylene, or nylon woven pile with nylon-fabric or aluminum-strip backing.

**Okaloosa County TDC – Destin Fort Walton Beach Convention Center
Exterior Accessibility**

2.8 FABRICATION

- A. General: Factory fabricate automatic entrance components to designs, sizes, and thicknesses indicated and to comply with indicated standards.
- B. Framing: Provide automatic entrances as prefabricated assemblies. Complete fabrication, assembly, finishing, hardware application, and other work before shipment to Project site.
 - 1. Provide components with concealed fasteners and anchor and connection devices.
 - 2. Fabricate components with accurately fitted joints, with ends coped or mitered to produce hairline joints free of burrs and distortion.
 - 3. Fabricate exterior components to drain water passing joints, condensation occurring within framing members, and moisture migrating within system to exterior.
 - 4. Provide anchorage and alignment brackets for concealed support of assembly from building structure.
 - 5. Allow for thermal expansion of exterior units.
- C. Doors: Factory fabricated and assembled in profiles indicated. Reinforce as required to support imposed loads and for installing hardware.
- D. Door Operators: Factory fabricated and installed in headers, including adjusting and testing.
- E. Glazing: Fabricate framing with minimum glazing edge clearances for thickness and type of glazing indicated, according to GANA's "Glazing Manual."
- F. Hardware: Factory install hardware to greatest extent possible; remove only as required for final finishing operation and for delivery to and installation at Project site. Cut, drill, and tap for factory-installed hardware before applying finishes.
 - 1. Provide sliding-type weather stripping, mortised into door, at perimeter of doors and breakaway sidelites.
- G. Controls:
 - 1. General: Factory install activation and safety devices in doors and headers as required by BHMA A156.10 for type of door and direction of travel.

2.9 ALUMINUM FINISHES

- A. High-Performance Organic Finish: Two-coat fluoropolymer finish complying with AAMA 2605 and containing not less than 70 percent PVDF resin by weight in color coat. Prepare, pretreat, and apply coating to exposed metal surfaces to comply with coating and resin manufacturers' written instructions.
 - 1. Color and Gloss: To match adjacent storefront systems.

**Okaloosa County TDC – Destin Fort Walton Beach Convention Center
Exterior Accessibility**

PART 3 - EXECUTION**3.1 INSTALLATION**

- A. General: Install automatic entrances according to manufacturer's written instructions and cited BHMA A156.10 for direction of pedestrian travel, including signage, controls, wiring, and connection to the building's power supply.
 - 1. Do not install damaged components. Fit frame joints to produce hairline joints free of burrs and distortion. Rigidly secure nonmovement joints. Seal joints watertight.
 - 2. Where aluminum will contact dissimilar metals, protect against galvanic action by painting contact surfaces with primer or by applying sealant or tape recommended by manufacturer for this purpose.
 - 3. Where aluminum will contact concrete or masonry, protect against corrosion by painting contact surfaces with bituminous coating.

- B. Entrances: Install automatic entrances plumb and true in alignment with established lines and grades without warp or rack of framing members and doors. Anchor securely in place.
 - 1. Install surface-mounted hardware using concealed fasteners to greatest extent possible.
 - 2. Set headers, carrier assemblies, tracks, operating brackets, and guides level and true to location with anchorage for permanent support.
 - 3. Install components to drain water passing joints, condensation occurring within framing members, and moisture migrating within system to exterior.
 - 4. Level recesses for recessed thresholds using nonshrink grout.

- C. Door Operators: Connect door operators to electrical power distribution system.

- D. Access-Control Devices: Connect access-control devices to access-control system, as specified in Section 281300 "Access Control Software and Database Management."

- E. Controls: Install and adjust activation and safety devices according to manufacturer's written instructions and cited BHMA standard for direction of pedestrian travel. Connect control wiring according to Section 260519 "Low-Voltage Electrical Power Conductors and Cables."

- F. Sealants: Comply with requirements specified in Section 079200 "Joint Sealants" to provide weathertight installation.
 - 1. Set thresholds, bottom-guide-track system, framing members and flashings in full sealant bed.
 - 2. Seal perimeter of framing members with sealant.

- G. Signage: Apply signage on both sides of each door and breakaway sidelite, as required by cited BHMA standard for direction of pedestrian travel.

- H. Wiring within Automatic Entrance Enclosures: Bundle, lace, and train conductors to terminal points with no excess and without exceeding manufacturer's written limitations on bending radii. Provide and use lacing bars and distribution spools.

**Okaloosa County TDC – Destin Fort Walton Beach Convention Center
Exterior Accessibility**

3.2 FIELD QUALITY CONTROL

- A. Certified Inspector: Engage a Certified Inspector to test and inspect components, assemblies, and installations, including connections.
- B. Perform the following tests and inspections with the assistance of a factory-authorized service representative:
 - 1. Test and inspect each automatic entrance, using AAADM inspection forms, to determine compliance of installed systems with applicable BHMA standards.
- C. Automatic entrances will be considered defective if they do not pass tests and inspections.
- D. Prepare test and inspection reports.

3.3 ADJUSTING

- A. Adjust hardware, moving parts, door operators, and controls to function smoothly, and lubricate as recommended by manufacturer; comply with requirements of applicable BHMA standards.
- B. Readjust door operators and controls after repeated operation of completed installation equivalent to three days' use by normal traffic (100 to 300 cycles).

3.4 DEMONSTRATION

- A. Engage a factory-authorized service representative to train Owner's maintenance personnel to adjust, operate, and maintain automatic entrances.

END OF SECTION 084229

**Okaloosa County TDC – Destin Fort Walton Beach Convention Center
Exterior Accessibility**

SECTION 087100 - DOOR HARDWARE

PART 1 - GENERAL

1.1 SUMMARY:

- A. Section Includes: Finish Hardware for door openings, except as otherwise specified herein.
 - 1. Door hardware for steel (hollow metal) doors.
 - 2. Keyed cylinders as indicated.
- B. Related Sections:
 - 1. Division 08: Hollow Metal Doors and Frames.
- C. References: Comply with applicable requirements of the following standards. Where these standards conflict with other specific requirements, the most restrictive shall govern.
 - 1. Builders Hardware Manufacturing Association (BHMA)
 - 2. NFPA 101 Life Safety Code, 2015
 - 3. NFPA 80 – Standard for Fire Doors and Other Opening Protectives, 2013
 - 4. ANSI-A156.xx- Various Performance Standards for Finish Hardware
 - 5. UL10C – Positive Pressure Fire Test of Door Assemblies
 - 6. ANSI-A117.1 – Accessible and Usable Buildings and Facilities, 2009
 - 7. DHI /ANSI A115.IG – Installation Guide for Doors and Hardware, 1994
 - 8. FBC Building Code, 2017
- D. Intent of Hardware Groups
 - 1. Should items of hardware not definitely specified be required for completion of the Work, furnish such items of type and quality comparable to adjacent hardware and appropriate for service required.
 - 2. Where items of hardware are not definitely or correctly specified, but are required for completion of the Work, a written statement of such omission, error, or other discrepancy is to be submitted to Architect, prior to date specified for receipt of bids for clarification by addendum; or furnish such items in the type and quality established by this specification, and appropriate to the service intended.

1.2 SUBSTITUTIONS:

- A. Comply with Division 01.

1.3 SUBMITTALS:

- A. Comply with Division 01.
- B. Special Submittal Requirements: Combine submittals of this Section with Sections listed below to ensure the "design intent" of the system/assembly is understood and can be reviewed together.
- C. Product Data: Manufacturer's specifications and technical data including the following:
 - 1. Detailed specification of construction and fabrication.
 - 2. Manufacturer's installation instructions.

**Okaloosa County TDC – Destin Fort Walton Beach Convention Center
Exterior Accessibility**

3. Wiring diagrams for each electric product specified. Coordinate voltage with electrical before submitting.
 4. Submit 6 copies of catalog cuts with hardware schedule.
- D. Shop Drawings - Hardware Schedule: Submit 6 complete reproducible copy of detailed hardware schedule in a vertical format.
1. List groups and suffixes in proper sequence.
 2. Completely describe door and list architectural door number.
 3. Manufacturer, product name, and catalog number.
 4. Function, type, and style.
 5. Size and finish of each item.
 6. Mounting heights.
 7. Explanation of abbreviations and symbols used within schedule.
 8. Detailed wiring diagrams, specially developed for each opening, indicating all electric hardware, security equipment and access control equipment, and door and frame rough-ins required for specific opening.
- E. Templates: Submit templates and "reviewed Hardware Schedule" to door and frame supplier and others as applicable to enable proper and accurate sizing and locations of cutouts and reinforcing.
1. Templates, wiring diagrams and "reviewed Hardware Schedule" of electrical terms to electrical for coordination and verification of voltages and locations.
- F. Samples: (If requested by the Architect)
1. 1 sample of Lever and Rose or Escutcheon design.
 2. 3 samples of metal finishes
- G. Contract Closeout Submittals: Comply with Division 1 including specific requirements indicated.
1. Operating and maintenance manuals: Submit 3 sets containing the following.
 - a. Complete information in care, maintenance, and adjustment, and data on repair and replacement parts, and information on preservation of finishes.
 - b. Catalog pages for each product.
 - c. Name, address, and phone number of local representatives for each manufacturer.
 - d. Parts list for each product.
 2. Copy of final hardware schedule, edited to reflect, "As installed".
 3. Copy of final keying schedule
 4. As installed "Wiring Diagrams" for each piece of hardware connected to power, both low voltage and 110 volts.
 5. One set of special tools required for maintenance and adjustment of hardware, including changing of cylinders.

1.4 QUALITY ASSURANCE

- A. Comply with Division 1.

**Okaloosa County TDC – Destin Fort Walton Beach Convention Center
Exterior Accessibility**

1. Statement of qualification for distributor and installers.
2. Statement of compliance with regulatory requirements and single source responsibility.
3. Distributor's Qualifications: Firm with 3 years of experience in the distribution of commercial hardware.
 - a. Distributor to employ full time Architectural Hardware Consultants (AHC) for the purpose of scheduling and coordinating hardware and establishing keying schedule.
 - b. Hardware Schedule shall be prepared and signed by an AHC.
4. Installer's Qualifications: Firm with 3 years of experience in installation of similar hardware to that required for this Project, including specific requirements indicated.
5. Regulatory Label Requirements: Provide testing agency label or stamp on hardware for labeled openings.
 - a. Provide UL listed hardware for labeled and 20-minute openings in conformance with requirements for class of opening scheduled.
 - b. Underwriters Laboratories requirements have precedence over this specification where conflict exists.
6. Single Source Responsibility: Except where specified in hardware schedule, furnish products of only one manufacturer for each type of hardware.

- B. Review Project for extent of finish hardware required to complete the Work. Where there is a conflict between these Specifications and the existing hardware, notify the Architect in writing and furnish hardware in compliance with the Specification unless otherwise directed in writing by the Architect.

1.5 DELIVERY, STORAGE, AND HANDLING

- A. Packing and Shipping: Comply with Division 01.
1. Deliver products in original unopened packaging with legible manufacturer's identification.
 2. Package hardware to prevent damage during transit and storage.
 3. Mark hardware to correspond with "reviewed hardware schedule".
 4. Deliver hardware to door and frame manufacturer upon request.
- B. Storage and Protection: Comply with manufacturer's recommendations.

1.6 PROJECT CONDITIONS:

- A. Coordinate hardware with other work. Furnish hardware items of proper design for use on doors and frames of the thickness, profile, swing, security and similar requirements indicated, as necessary for the proper installation and function, regardless of omissions or conflicts in the information on the Contract Documents.
- B. Review Shop Drawings for doors and entrances to confirm that adequate provisions will be made for the proper installation of hardware.

1.7 WARRANTY:

- A. Refer to Conditions of the Contract

**Okaloosa County TDC – Destin Fort Walton Beach Convention Center
Exterior Accessibility**

B. Manufacturer’s Warranty:

- 1. Closers: Ten years
- 2. Locksets & Cylinders: Three years
- 3. All other Hardware: Two years.

1.8 OWNER’S INSTRUCTION:

- A. Instruct Owner’s personnel in operation and maintenance of hardware units.

1.9 MAINTENANCE:

- A. Extra Service Materials: Deliver to Owner extra materials from same production run as products installed. Package products with protective covering and identify with descriptive labels. Comply with Division 1 Closeout Submittals Section.

- 1. Special Tools: Provide special wrenches and tools applicable to each different or special hardware component.
- 2. Maintenance Tools: Provide maintenance tools and accessories supplied by hardware component manufacturer.
- 3. Delivery, Storage and Protection: Comply with Owner’s requirements for delivery, storage and protection of extra service materials.

- B. Maintenance Service: Submit for Owner’s consideration maintenance service agreement for electronic products installed.

PART 2 - PRODUCTS

2.1 MANUFACTURERS:

- A. The following manufacturers are approved subject to compliance with requirements of the Contract Documents. Approval of manufacturers other than those listed shall be in accordance with Division 1.

<u>Item:</u>	<u>Manufacturer:</u>	<u>Approved:</u>
Hinges	Stanley	Bommer, McKinney
Locksets	Best 45H	Schlage 9000, Sargent 82
Cylinders / Cores	Best 12E	
Door Closers	Stanley D-4551	Dorma 8900, Sargent 351
Protection Plates	Trimco	Burns, Rockwood
Door Stops	Trimco	Burns, Rockwood
Flush Bolts	Trimco	ABH, Burns
Threshold & Gasketing	National Guard	Reese, K.N. Crowder

2.2 MATERIALS:

- A. Hinges: Shall be Five Knuckle Ball bearing hinges
 - 1. Template screw hole locations
 - 2. Bearings are to be fully hardened.

**Okaloosa County TDC – Destin Fort Walton Beach Convention Center
Exterior Accessibility**

3. Bearing shell is to be consistent shape with barrel.
4. Minimum of 2 permanently lubricated non-detachable bearings on standard weight hinge and 4 permanently lubricated bearing on heavy weight hinges.
5. Equip with easily seated, non-rising pins.
6. Non-Removable Pin screws shall be slotted stainless steel screws.
7. Hinges shall be full polished, front, back and barrel.
8. Hinge pin is to be fully plated.
9. Bearing assembly is to be installed after plating.
10. Sufficiently sized to allow 180-degree swing of door
11. Furnish five knuckles with flush ball bearings
12. Provide hinge type as listed in schedule.
13. Provide NRP (non-removeable pin) hinges on lockable reverse bevel doors.
14. Furnish 2 hinges per leaf (top and bottom halves).
15. Coordinate with Door / Frame Manufacturer for specific hinge locations for fire rated Dutch doors
16. Tested and approved by BHMA for all applicable ANSI Standards for type, size, function and finish
17. UL10C listed for fire rated doors.

B. Mortise Type Locks and Latch Sets:

1. Tested and approved by BHMA for ANSI A156.13, Series 1000, Operational Grade 1, Extra-Heavy Duty, Security Grade 2 and be UL10C.
2. Furnish UL or recognized independent laboratory certified mechanical operational testing to 4 million cycles minimum.
3. Provide 9001-Quality Management and 14001-Environmental Management.
4. Fit ANSI A115.1 door preparation
5. Functions and design as indicated in the hardware groups
6. Solid, one-piece, 3/4-inch (19mm) throw, anti-friction latch bolt made of self-lubricating stainless steel
7. Deadbolt functions shall have 1 inch (25mm) throw bolt made of hardened stainless steel
8. Latch bolt and Deadbolt are to extend into the case a minimum of 3/8 inch (9.5mm) when fully extended
9. Auxiliary deadlatch to be made of one-piece stainless steel, permanently lubricated
10. Provide sufficiently sized, curved lip strike to protect door trim
11. Lever handles must be of forged or cast brass, bronze or stainless steel construction and conform to ANSI A117.1. Levers that contain a hollow cavity are not acceptable.
12. Lock shall have self-aligning, thru-bolted trim.
13. Levers to operate a roller bearing spindle hub mechanism
14. Mortise cylinders of lock shall have a concealed internal setscrew for securing the cylinder to the lockset. The internal setscrew will be accessible only by removing the core, with the control key, from the cylinder body.
15. Spindle to be designed to prevent forced entry from attacking of lever
16. Provide lock sets with 7-pin removable and interchangeable core cylinders
17. Each lever to have independent spring mechanism controlling it
18. Core face must be the same finish as the lockset.

C. Cylindrical Type Locks and Latch Sets:

1. Tested and approved by BHMA for ANSI A156.2, Series 4000, Operational Grade 1, Extra-Heavy Duty, and be UL10C listed.
2. Provide 9001-Quality Management and 14001-Environmental Management.
3. Fit modified ANSI A115.2 door preparation.
4. Locksets and cores to be of the same manufacturer to maintain complete lockset warranty

**Okaloosa County TDC – Destin Fort Walton Beach Convention Center
Exterior Accessibility**

5. Locksets to have anti-rotational studs that are thru-bolted
 6. Keyed lever shall not have exposed “keeper” hole
 7. Each lever to have independent spring mechanism controlling it
 8. 2-3/4 inch (70 mm) backset
 9. 9/16 inch (14 mm) throw latch bolt
 10. Provide sufficiently sized curved lip strike to minimally protect door and trim
 11. Outside lever sleeve to be seamless, of one-piece construction made of a hardened steel alloy
 12. Keyed lever to be removable only after core is removed, by authorized control key
 13. Provide locksets with 7-pin removable and interchangeable core cylinders
 14. Hub, side plate, shrouded rose, locking pin to be a one-piece casting with a shrouded locking lug.
 15. Locksets outside locked lever must withstand minimum 1400 inch pounds of torque. In excess of that, a replaceable part will shear. Key from outside and inside lever will still operate lockset.
 16. Core face must be the same finish as the lockset.
 17. Functions and design as indicated in the hardware groups.
- D. Door Closers shall:
1. Tested and approved by BHMA for ANSI 156.4, Grade 1
 2. UL10C certified
 3. Provide 9001-Quality Management and 14001-Environmental Management.
 4. Closer shall have extra-duty arms and knuckles
 5. Conform to ANSI 117.1
 6. Maximum 2 7/16 inch case projection with non-ferrous cover
 7. Separate adjusting valves for closing and latching speed, and backcheck
 8. Provide adapter plates, shim spacers and blade stop spacers as required by frame and door conditions
 9. Full rack and pinion type closer with 1-1/2” minimum bore
 10. Mount closers on non-public side of door, unless otherwise noted in specification
 11. Closers shall be non-handed, non-sized and multi-sized.
- E. Door Stops: Provide a dome floor or wall stop for every opening as listed in the hardware sets.
1. Wall stops and floor stops shall be wrought bronze, brass or stainless steel.
 2. Provide fastener suitable for wall construction.
 3. Coordinate reinforcement of walls where wall stop is specified.
 4. Provide dome stops where wall stops are not practical. Provide spacers or carpet riser for floor conditions encountered
- F. Kickplates: Provide with four beveled edges ANSI J102, 10 inches high by width less 2 inches on single doors and 1 inch on pairs of doors. Furnish oval-head countersunk screws to match finish.
- G. Mop plates: Provide with four beveled edges ANSI J103, 4 inches high by width less 1 inch on single doors and 1 inch on pairs of doors. Furnish oval-head countersunk screws to match finish.
1. Provide cutouts for hardware as listed in the hardware sets.
 2. Provide Warnock Hersey labeled plates for 3 hour metal fire doors where allowed by local authority.
- H. Door Bolts: Flush bolts for wood or metal doors.
1. Provide an Automatic bolts, Certified ANSI/BHMA 156.3 Type 25 for hollow metal label doors.
 2. Provide a set of Automatic bolts, Certified ANSI/BHMA 156.3 Type 27 at wood label doors.
 3. Manual flush bolts, Certified ANSI/BHMA 156.16 at openings where allowed local authority.

**Okaloosa County TDC – Destin Fort Walton Beach Convention Center
Exterior Accessibility**

4. Provide Dust Proof Strike, Certified ANSI/BHMA 156.16 at doors with flush bolts without thresholds.
 - I. Seals: All seals shall be finished to match adjacent frame color. Seals shall be furnished as listed in schedule. Material shall be UL listed for labeled openings.
 - J. Weather stripping: Provide at head and jambs only those units where resilient or flexible seal strip is easily replaceable. Where bar-type weather strip is used with parallel arm mounted closers install weather strip first.
 1. Weather strip shall be resilient seal of (Neoprene, Polyurethane, Vinyl, Pile, Nylon Brush, Silicone)
 2. UL10C Positive Pressure rated seal set when required.
 - K. Door Bottoms/Sweeps: Surface mounted or concealed door bottom where listed in the hardware sets.
 1. Door seal shall be resilient seal of (Neoprene, Polyurethane, Nylon Brush, Silicone)
 2. UL10C Positive Pressure rated seal set when required.
 - L. Thresholds: Thresholds shall be aluminum beveled type with maximum height of ½” for conformance with ADA requirements. Furnish as specified and per details. Provide fasteners and screws suitable for floor conditions.
- 2.3 FINISH:
- A. Designations used in Schedule of Finish Hardware - 3.05, and elsewhere to indicate hardware finishes are those listed in ANSI/BHMA A156.18 including coordination with traditional U.S. finishes shown by certain manufacturers for their products
 - B. Powder coat door closers to match other hardware, unless otherwise noted.
 - C. Aluminum items shall be finished to match predominant adjacent material. Seals to coordinate with frame color.
- 2.4 KEYS AND KEYING:
- A. Provide keyed brass construction cores and keys during the construction period. Construction control and operating keys and core shall not be part of the Owner's permanent keying system or furnished in the same keyway (or key section) as the Owner's permanent keying system. Permanent cores and keys (prepared according to the accepted keying schedule) will be furnished to the Owner.
 - B. Cylinders, removable and interchangeable core system: Expand Owner’s existing CORMAX 7-pin key system.
 - C. Permanent keys and cores: Stamped with the applicable key mark for identification. These visual key control marks or codes will not include the actual key cuts. Permanent keys will also be stamped "Do Not Duplicate."
 - D. Transmit Grand Master Keys, Master Keys and other Security keys to Owner by Registered Mail, return receipt requested.
 - E. Furnish keys in the following quantities. Coordinate with Owner for specific key requirements:
 1. 2 each Change Keys each keyed core
 2. 5 each Construction Master Keys

**Okaloosa County TDC – Destin Fort Walton Beach Convention Center
Exterior Accessibility**

3. 1 each Construction Control Key
 4. 1 each Control Key
- F. The Owner, or the Owner's agent, will install permanent cores and return the construction cores to the Hardware Supplier. Construction cores and keys remain the property of the Hardware Supplier.
- G. Keying Schedule: Arrange for a keying meeting, and programming meeting with Architect Owner and hardware supplier, and other involved parties to ensure locksets and locking hardware, are functionally correct and keying and programming complies with project requirements. Furnish 3 typed copies of keying and programming schedule to Architect.

PART 3 - EXECUTION

3.1 EXAMINATION

- A. Verification of conditions: Examine doors, frames, related items and conditions under which Work is to be performed and identify conditions detrimental to proper and or timely completion.
1. Do not proceed until unsatisfactory conditions have been corrected.

3.2 HARDWARE LOCATIONS:

- A. Mount hardware units at heights indicated in the following publications except as specifically indicated or required to comply with the governing regulations.
1. Recommended Locations for Builder's Hardware for Standard Steel Doors and Frames, by the Door and Hardware Institute (DHI).
 2. Recommended locations for Architectural Hardware for flush wood doors (DHI).
 3. WDMA Industry Standard I.S.-1A-04, Industry Standard for Architectural wood flush doors.

3.3 INSTALLATION:

- A. Install each hardware item per manufacturer's instructions and recommendations. Do not install surface mounted items until finishes have been completed on the substrate. Set units level, plumb and true to line and location. Adjust and reinforce the attachment substrate as necessary for proper installation and operation.
- B. Conform to local governing agency security ordinance.
- C. Install Conforming to ICC/ANSI A117.1 Accessible and Usable Building and Facilities.
1. Adjust door closer sweep periods so that from the open position of 70 degrees, the door will take at least 3 seconds to move to a point 3 inches from the latch, measured to the landing side of the door.
- D. Installed hardware using the manufacturers fasteners provided. Drill and tap all screw holes located in metallic materials. Do not use "Riv-Nuts" or similar products.

**Okaloosa County TDC – Destin Fort Walton Beach Convention Center
Exterior Accessibility**

3.4 FIELD QUALITY CONTROL AND FINAL ADJUSTMENT

- A. Contractor/Installers, Field Services: After installation is complete, contractor shall inspect the completed door openings on site to verify installation of hardware is complete and properly adjusted, in accordance with both the Contract Documents and final shop drawings.
1. Check and adjust closers to ensure proper operation.
 2. Check latch sets, lock sets and exit devices are properly installed and adjusted to ensure proper operation.
 - a. Verify levers are free from binding.
 - b. Ensure latch bolts and automatic flush bolts fully and easily engage strikes and that the hardware is functioning properly.
 3. Report findings, in writing, to architect indicating that all hardware is installed and functioning properly. Include recommendations outlining corrective actions for improperly functioning hardware if required.

3.5 SCHEDULE OF FINISH HARDWARE:

Manufacturer List

<u>Code</u>	<u>Name</u>
BE	Best Access Systems
NA	National Guard
SD	Stanley Door Closers
SH	Stanley Hinges
TR	Trimco

Option List

<u>Code</u>	<u>Description</u>
B4E	Beveled 4 Edges
CSK	COUNTER SINKING OF KICK and MOP PLATES

Finish List

<u>Code</u>	<u>Description</u>
626	Satin Chromium Plated
630	Satin Stainless Steel
689	Aluminum Painted
US32D	Stainless Steel, Dull
SS	Stainless Steel

**Okaloosa County TDC – Destin Fort Walton Beach Convention Center
Exterior Accessibility**

Hardware Sets

SET #1

001 - Ticket Booth

3'0" x 7'0" x 1-3/4" HMD / HMF; Dutch Door w/ Shelf on push and pull side of door – UL 45 Minutes (out-swinging)

4 ea.	Hinge	CB191 4-1/2" X 4-1/2" NRP	US32D	SH	
1 ea.	Mortise Lock (Classroom)	45H-7R14H S1	626	BE	
1 ea.	Mortise Cyl./ SFIC	12E-72 PATD	626	BE	
1 ea.	Automatic Flush Bolt	3810	630	TR	
1 ea.	Door Closer	4551 Std. w/ PA Brkt.	689	SD	
<i>(Note: Mount parallel arm, templated for 180 degree swing)</i>					
1 ea.	Electromagnetic Holder	2100	630	ABH	
1 ea.	Kick Plate	K0050 8" x 2" LDW	630		TR
1 ea.	Gasketing	5075B at Head & Jambs	BLK	NA	
1 ea.	Door Sweep	C627A	ALUM	NA	
1 ea.	Wall Stop	1270CX	SS	TR	
1 ea.	Horizontal Astragal (top half)	<i>Provided by Door Manufacturer</i>			
1 ea.	Power Supply	<i>Provided by Fire Alarm Contractor</i>			
1 ea.	Fire Alarm Tie-In	<i>Wire and installation by Fire Alarm Contractor</i>			

Note: Magnetic Holder releases automatically upon fire alarm signal or loss of power. Coordinate with door manufacturer for all specific hardware location and preparation requirements.

END OF SECTION 087100

**Okaloosa County TDC – Destin Fort Walton Beach Convention Center
Exterior Accessibility**

SECTION 092216 - NON-STRUCTURAL METAL FRAMING

PART 1 - GENERAL

1.1 SUMMARY

A. Section Includes:

1. Non-load-bearing steel framing systems for interior partitions.
2. Suspension systems for interior ceilings and soffits.

1.2 ACTION SUBMITTALS

A. Product Data: For each type of product.

1.3 INFORMATIONAL SUBMITTALS

A. Product Certificates: For each type of code-compliance certification for studs and tracks.

1.4 QUALITY ASSURANCE

- A. Code-Compliance Certification of Studs and Tracks: Provide documentation that framing members are certified according to the product-certification program of the Certified Steel Stud Association, the Steel Framing Industry Association or the Steel Stud Manufacturers Association.

PART 2 - PRODUCTS

2.1 FRAMING SYSTEMS

A. Framing Members, General: Comply with ASTM C754 for conditions indicated.

1. Steel Sheet Components: Comply with ASTM C645 requirements for steel unless otherwise indicated.
2. Protective Coating: ASTM A653/A653M, G40 (Z120), hot-dip galvanized unless otherwise indicated.

B. Studs and Tracks: ASTM C645. Use either conventional steel studs and tracks or embossed, high-strength steel studs and tracks.

1. Minimum Base-Steel Thickness: As required by performance requirements for horizontal deflection.
2. Depth: As indicated on Drawings

**Okaloosa County TDC – Destin Fort Walton Beach Convention Center
Exterior Accessibility**

- C. Slip-Type Head Joints: Where indicated, provide one of the following:
1. Clip System: Clips designed for use in head-of-wall deflection conditions that provide a positive attachment of studs to tracks while allowing minimum vertical movement.
 2. Single Long-Leg Track System: ASTM C645 top track with 2-inch- (51-mm-) deep flanges in thickness not less than indicated for studs, installed with studs friction fit into top track and with continuous bridging located within 12 inches (305 mm) of the top of studs to provide lateral bracing.
 3. Double-Track System: ASTM C645 top outer tracks, inside track with 2-inch- (51-mm-) deep flanges in thickness not less than indicated for studs and fastened to studs, and outer track sized to friction-fit over inner track.
 4. Deflection Track: Steel sheet top track manufactured to prevent cracking of finishes applied to interior partition framing resulting from deflection of structure above; in thickness not less than indicated for studs and in width to accommodate depth of studs.
- D. Flat Strap and Backing Plate: Steel sheet for blocking and bracing in length and width indicated.
1. Minimum Base-Steel Thickness 0.0329 inch (0.836 mm).
- E. Cold-Rolled Channel Bridging: Steel, 0.0538-inch (1.367-mm) minimum base-steel thickness, with minimum 1/2-inch- (13-mm-) wide flanges.
1. Depth: 1-1/2 inches (38 mm).
 2. Clip Angle: Not less than 1-1/2 by 1-1/2 inches (38 by 38 mm), 0.068-inch- (1.72-mm-) thick, galvanized steel.
- F. Hat-Shaped, Rigid Furring Channels: ASTM C645.
1. Minimum Base-Steel Thickness 0.0329 inch (0.836 mm).
 2. Depth: 1-1/2 inches (38 mm).
- G. Z-Shaped Furring: With slotted or nonslotted web, face flange of 1-1/4 inches (32 mm), wall attachment flange of 7/8 inch (22 mm), minimum uncoated-steel thickness of 0.0179 inch (0.455 mm), and depth required to fit insulation thickness indicated.

2.2 SUSPENSION SYSTEMS

- A. Tie Wire: ASTM A641/A641M, Class 1 zinc coating, soft temper, 0.062-inch- (1.59-mm-) diameter wire, or double strand of 0.048-inch- (1.21-mm-) diameter wire.
- B. Hanger Attachments to Concrete:
1. Post-Installed Anchors: Fastener systems with an evaluation report acceptable to authorities having jurisdiction, based on ICC-ES or AC308 as appropriate for the substrate.
 - a. Uses: Securing hangers to structure.
 - b. Material for Interior Locations: Carbon-steel components zinc-plated to comply with ASTM B633 or ASTM F1941 (ASTM F1941M), Class Fe/Zn 5, unless otherwise indicated.

**Okaloosa County TDC – Destin Fort Walton Beach Convention Center
Exterior Accessibility**

- C. Wire Hangers: ASTM A641/A641M, Class 1 zinc coating, soft temper, 0.16 inch (4.12 mm) in diameter.
- D. Flat Hangers: Steel sheet, 1 by 3/16 inch (25 by 5 mm) by length indicated.
- E. Carrying Channels (Main Runners): Cold-rolled, commercial-steel sheet with a base-steel thickness of 0.0538 inch (1.367 mm) and minimum 1/2-inch- (13-mm-) wide flanges.
 - 1. Depth: 2 inches (51 mm).
- F. Furring Channels (Furring Members):
 - 1. Cold-Rolled Channels: 0.0538-inch (1.367-mm) uncoated-steel thickness, with minimum 1/2-inch- (13-mm-) wide flanges, 3/4 inch (19 mm) deep.
 - 2. Steel Studs and Tracks: ASTM C645.
 - a. Minimum Base-Steel Thickness: 0.0329 inch (0.836 mm).
 - b. Depth: 3-5/8 inches (92 mm).
 - 3. Hat-Shaped, Rigid Furring Channels: ASTM C645, 7/8 inch (22 mm) deep.
 - a. Minimum Base-Steel Thickness: 0.0329 inch (0.836 mm).

2.3 AUXILIARY MATERIALS

- A. General: Provide auxiliary materials that comply with referenced installation standards.
 - 1. Fasteners for Steel Framing: Of type, material, size, corrosion resistance, holding power, and other properties required to fasten steel members to substrates.
- B. Isolation Strip at Exterior Walls:
 - 1. Foam Gasket: Adhesive-backed, closed-cell vinyl foam strips that allow fastener penetration without foam displacement, 1/8 inch (3.2 mm) thick, in width to suit steel stud size.

PART 3 - EXECUTION

3.1 INSTALLATION, GENERAL

- A. Installation Standard: ASTM C754.
 - 1. Gypsum Plaster Assemblies: Also comply with requirements in ASTM C841 that apply to framing installation.
 - 2. Portland Cement Plaster Assemblies: Also comply with requirements in ASTM C1063 that apply to framing installation.
 - 3. Gypsum Veneer Plaster Assemblies: Also comply with requirements in ASTM C844 that apply to framing installation.

**Okaloosa County TDC – Destin Fort Walton Beach Convention Center
Exterior Accessibility**

4. Gypsum Board Assemblies: Also comply with requirements in ASTM C840 that apply to framing installation.
- B. Install framing and accessories plumb, square, and true to line, with connections securely fastened.
- C. Install supplementary framing, and blocking to support fixtures, equipment services, heavy trim, grab bars, toilet accessories, furnishings, or similar construction.
- D. Install bracing at terminations in assemblies.
- E. Do not bridge building control and expansion joints with non-load-bearing steel framing members. Frame both sides of joints independently.

3.2 INSTALLING FRAMED ASSEMBLIES

- A. Install framing system components according to spacings indicated, but not greater than spacings required by referenced installation standards for assembly types.
- B. Where studs are installed directly against exterior masonry walls or dissimilar metals at exterior walls, install isolation strip between studs and exterior wall.
- C. Install studs so flanges within framing system point in same direction.
- D. Install tracks at floors and overhead supports. Extend framing full height to structural supports or substrates above suspended ceilings except where partitions are indicated to terminate at suspended ceilings. Continue framing around ducts that penetrate partitions above ceiling.
 1. Slip-Type Head Joints: Where framing extends to overhead structural supports, install to produce joints at tops of framing systems that prevent axial loading of finished assemblies.
 2. Door Openings: Screw vertical studs at jambs to jamb anchor clips on door frames; install track section (for cripple studs) at head and secure to jamb studs.
 - a. Install two studs at each jamb unless otherwise indicated.
 - b. Install cripple studs at head adjacent to each jamb stud, with a minimum 1/2-inch (13-mm) clearance from jamb stud to allow for installation of control joint in finished assembly.
 - c. Extend jamb studs through suspended ceilings and attach to underside of overhead structure.
 3. Other Framed Openings: Frame openings other than door openings the same as required for door openings unless otherwise indicated. Install framing below sills of openings to match framing required above door heads.
 4. Fire-Resistance-Rated Partitions: Install framing to comply with fire-resistance-rated assembly indicated and support closures and to make partitions continuous from floor to underside of solid structure.

**Okaloosa County TDC – Destin Fort Walton Beach Convention Center
Exterior Accessibility**

- a. Firestop Track: Where indicated, install to maintain continuity of fire-resistance-rated assembly indicated.
5. Sound-Rated Partitions: Install framing to comply with sound-rated assembly indicated.
6. Curved Partitions:
 - a. Bend track to uniform curve and locate straight lengths so they are tangent to arcs.
 - b. Begin and end each arc with a stud, and space intermediate studs equally along arcs. On straight lengths of no fewer than two studs at ends of arcs, place studs 6 inches (150 mm) o.c.
- E. Direct Furring:
 1. Screw to wood framing.
 2. Attach to concrete or masonry with stub nails, screws designed for masonry attachment, or powder-driven fasteners spaced 24 inches (610 mm) o.c.
- F. Z-Shaped Furring Members:
 1. Erect insulation, specified in Section 072100 "Thermal Insulation," vertically and hold in place with Z-shaped furring members spaced [24 inches (610 mm)] <Insert dimension> o.c.
 2. Except at exterior corners, securely attach narrow flanges of furring members to wall with concrete stub nails, screws designed for masonry attachment, or powder-driven fasteners spaced 24 inches (610 mm) o.c.
 3. At exterior corners, attach wide flange of furring members to wall with short flange extending beyond corner; on adjacent wall surface, screw-attach short flange of furring channel to web of attached channel. At interior corners, space second member no more than 12 inches (305 mm) from corner and cut insulation to fit.
- G. Installation Tolerance: Install each framing member so fastening surfaces vary not more than 1/8 inch (3 mm) from the plane formed by faces of adjacent framing.

3.3 INSTALLING CEILING SUSPENSION SYSTEMS

- A. Install suspension system components according to spacings indicated, but not greater than spacings required by referenced installation standards for assembly types.
- B. Isolate suspension systems from building structure where they abut or are penetrated by building structure to prevent transfer of loading imposed by structural movement.
- C. Suspend hangers from building structure as follows:
 1. Install hangers plumb and free from contact with insulation or other objects within ceiling plenum that are not part of supporting structural or suspension system.
 - a. Splay hangers only where required to miss obstructions and offset resulting horizontal forces by bracing, countersplaying, or other equally effective means.

**Okaloosa County TDC – Destin Fort Walton Beach Convention Center
Exterior Accessibility**

2. Where width of ducts and other construction within ceiling plenum produces hanger spacings that interfere with locations of hangers required to support standard suspension system members, install supplemental suspension members and hangers in the form of trapezes or equivalent devices.
 - a. Size supplemental suspension members and hangers to support ceiling loads within performance limits established by referenced installation standards.
 3. Wire Hangers: Secure by looping and wire tying, either directly to structures or to inserts, eye screws, or other devices and fasteners that are secure and appropriate for substrate, and in a manner that will not cause hangers to deteriorate or otherwise fail.
 4. Flat Hangers: Secure to structure, including intermediate framing members, by attaching to inserts, eye screws, or other devices and fasteners that are secure and appropriate for structure and hanger, and in a manner that will not cause hangers to deteriorate or otherwise fail.
 5. Do not attach hangers to steel roof deck.
 6. Do not attach hangers to permanent metal forms. Furnish cast-in-place hanger inserts that extend through forms.
 7. Do not attach hangers to rolled-in hanger tabs of composite steel floor deck.
 8. Do not connect or suspend steel framing from ducts, pipes, or conduit.
- D. Installation Tolerances: Install suspension systems that are level to within 1/8 inch in 12 feet (3 mm in 3.6 m) measured lengthwise on each member that will receive finishes and transversely between parallel members that will receive finishes.

END OF SECTION 092216

**Okaloosa County TDC – Destin Fort Walton Beach Convention Center
Exterior Accessibility**

SECTION 092400 - CEMENT PLASTERING

PART 1 - GENERAL

1.1 SUMMARY

A. Section Includes:

1. Exterior vertical plasterwork (stucco).
2. Exterior horizontal and nonvertical plasterwork (stucco).

1.2 ACTION SUBMITTALS

- A. Product Data: For each type of product.
- B. Samples: For each type of factory-prepared finish coat and for each color and texture specified.

PART 2 - PRODUCTS

2.1 PERFORMANCE REQUIREMENTS

- A. Fire-Resistance Ratings: Where indicated, provide cement plaster assemblies identical to those of assemblies tested for fire resistance according to ASTM E119 by a qualified testing agency.

2.2 METAL LATH

- A. Expanded-Metal Lath: ASTM C847, cold-rolled carbon-steel sheet with ASTM A653/A653M, **G60 (Z180)**, hot-dip galvanized-zinc coating.
 1. Diamond-Mesh Lath: **Flat, [2.5 lb/sq. yd. (1.4 kg/sq. m)**
 2. **3/8-Inch (10-mm) Rib Lath: 3.4 lb/sq. yd. (1.8 kg/sq. m)**

2.3 ACCESSORIES

- A. General: Comply with ASTM C1063, and coordinate depth of trim and accessories with thicknesses and number of plaster coats required.
- B. Metal Accessories:
 1. Foundation Weep Scream: Fabricated from hot-dip galvanized-steel sheet, ASTM A653/A653M, **G60 (Z180)** zinc coating.
 2. Cornerite: Fabricated from metal lath with ASTM A653/A653M, **G60 (Z180)**, hot-dip galvanized-zinc coating.

**Okaloosa County TDC – Destin Fort Walton Beach Convention Center
Exterior Accessibility**

3. External- (Outside-) Corner Reinforcement: Fabricated from metal lath with ASTM A653/A653M, **G60 (Z180)**, hot-dip galvanized-zinc coating.
 4. Cornerbeads: Fabricated from zinc or [zinc-coated (galvanized) steel.
 - a. Smallnose cornerbead with expanded flanges; use unless otherwise indicated.
 - b. Smallnose cornerbead with perforated flanges; use on curved corners.
 - c. Smallnose cornerbead with expanded flanges reinforced by perforated stiffening rib; use on columns and for finishing unit masonry corners.
 - d. Bullnose cornerbead, radius **3/4 inch (19 mm)** minimum, with expanded flanges; use at locations indicated on Drawings.
 5. Casing Beads: Fabricated from zinc or zinc-coated (galvanized) steel; square-edged style; with expanded flanges.
 6. Expansion Joints: Fabricated from zinc or zinc-coated (galvanized) steel; folded pair of unperforated screeds in M-shaped configuration; with expanded flanges.
- C. Plastic Accessories: Manufactured from high-impact PVC.
1. Cornerbeads: With perforated flanges.
 - a. Smallnose cornerbead; use unless otherwise indicated.
 - b. Bullnose cornerbead, radius **3/4-inch (19-mm)** minimum; use at locations indicated on Drawings.
 2. Casing Beads: With perforated flanges in depth required to suit plaster bases indicated and flange length required to suit applications indicated.
 - a. Square-edge style; use unless otherwise indicated.
 - b. Bullnose style, radius **3/4-inch (19-mm)** minimum; use at locations indicated on Drawings.
 3. Control Joints: One-piece-type, folded pair of unperforated screeds in M-shaped configuration; with perforated flanges and removable protective tape on plaster face of control joint.
 4. Expansion Joints: Two-piece type, formed to produce slip-joint and square-edged **1/2-inch- (13-mm-)** wide reveal; with perforated concealed flanges.

2.4 MISCELLANEOUS MATERIALS

- A. Water for Mixing and Finishing Plaster: Potable and free of substances capable of affecting plaster set or of damaging plaster, lath, or accessories.
- B. Fiber for Base Coat: Alkaline-resistant glass or polypropylene fibers, **1/2 inch (13 mm)** long, free of contaminants, manufactured for use in cement plaster.
- C. Bonding Compound: ASTM C932.
- D. Fasteners for Attaching Metal Lath to Substrates: ASTM C1063.

**Okaloosa County TDC – Destin Fort Walton Beach Convention Center
Exterior Accessibility**

- E. Wire: ASTM A641/A641M, Class 1 zinc coating, soft temper, not less than **0.0475-inch (1.21-mm)** diameter unless otherwise indicated.

2.5 PLASTER MATERIALS

- A. Portland Cement: ASTM C150/C150M, Type I.
 - 1. Color for Finish Coats: White.
- B. Masonry Cement: ASTM C91, Type N.
 - 1. Color for Finish Coats: White.
- C. Plastic Cement: ASTM C1328.
- D. Colorants for Job-Mixed Finish Coats: Colorfast mineral pigments that produce finish plaster color **to** match existing colors.
- E. Lime: ASTM C206, Type S; or ASTM C207, Type S.
- F. Sand Aggregate: ASTM C897.
 - 1. Color for Job-Mixed Finish Coats: White.
- G. Perlite Aggregate: ASTM C35.
- H. Ready-Mixed Finish-Coat Plaster: Mill-mixed portland cement, aggregates, coloring agents, and proprietary ingredients.
 - 1. Color: As selected by Architect from manufacturer's full range.
- I. Acrylic-Based Finish Coatings: Factory-mixed acrylic-emulsion coating systems formulated with colorfast mineral pigments and fine aggregates; for use over cement plaster base coats. Include manufacturer's recommended primers and sealing topcoats for acrylic-based finishes.
 - 1. Color: As selected by Architect from manufacturer's full range.

2.6 PLASTER MIXES

- A. General: Comply with ASTM C926 for applications indicated.
 - 1. Fiber Content: Add fiber to base-coat mixes after ingredients have mixed at least two minutes. Comply with fiber manufacturer's written instructions for fiber quantities in mixes, but do not exceed **1 lb of fiber/cu. yd. (0.6 kg of fiber/cu. m)** of cementitious materials.
- B. Base-Coat Mixes for Use over Metal Lath: Scratch and brown coats for three-coat plasterwork as follows:
 - 1. Portland Cement Mixes:

**Okaloosa County TDC – Destin Fort Walton Beach Convention Center
Exterior Accessibility**

- a. Scratch Coat: For cementitious material, mix 1 part portland cement and 3/4 to 1-1/2 parts lime. Use 2-1/2 to 4 parts aggregate per part of cementitious material.
 - b. Brown Coat: For cementitious material, mix 1 part portland cement and 3/4 to 1-1/2] parts lime. Use 3 to 5 parts aggregate per part of cementitious material, but not less than volume of aggregate used in scratch coat.
2. Masonry Cement Mixes:
- a. Scratch Coat: Mix 1 part masonry cement and 2-1/2 to 4 parts aggregate.
 - b. Brown Coat: Mix 1 part masonry cement and 3 to 5 parts aggregate, but not less than volume of aggregate used in scratch coat.
3. Portland and Masonry Cement Mixes:
- a. Scratch Coat: For cementitious material, mix 1 part portland cement and 1 part masonry cement. Use 2-1/2 to 4 parts aggregate per part of cementitious material.
 - b. Brown Coat: For cementitious material, mix 1 part portland cement and 1 part masonry cement. Use 3 to 5 parts aggregate per part of cementitious material, but not less than volume of aggregate used in scratch coat.
4. Plastic Cement Mixes:
- a. Scratch Coat: Mix 1 part plastic cement and 2-1/2 to 4 parts aggregate.
 - b. Brown Coat: Mix 1 part plastic cement and 3 to 5 parts aggregate, but not less than volume of aggregate used in scratch coat.
5. Portland and Plastic Cement Mixes:
- a. Scratch Coat: For cementitious material, mix 1 part plastic cement and 1 part portland cement. Use 2-1/2 to 4 parts aggregate per part of cementitious material.
 - b. Brown Coat: For cementitious material, mix 1 part plastic cement and 1 part portland cement. Use 3 to 5 parts aggregate per part of cementitious material, but not less than volume of aggregate used in scratch coat.
- C. Base-Coat Mixes for Use over Unit Masonry and Concrete: Single base (scratch) coat for two-coat plasterwork on low-absorption plaster bases as follows:
1. Portland Cement Mix: For cementitious material, mix 1 part portland cement and 0 to 3/4 part lime. Use 2-1/2 to 4 parts aggregate per part of cementitious material.
 2. Portland and Masonry Cement Mix: For cementitious material, mix 1 part portland cement and 1 part masonry cement. Use 2-1/2 to 4 parts aggregate per part of cementitious material.
 3. Plastic Cement Mix: Use 1 part plastic cement and 2-1/2 to 4 parts aggregate.
- D. Base-Coat Mixes for Use over Unit Masonry and Concrete: Single base (scratch) coat for two-coat plasterwork on high-absorption plaster bases as follows:
1. Portland Cement Mix: For cementitious material, mix 1 part portland cement and 3/4 to 1-1/2 parts lime. Use 2-1/2 to 4 parts aggregate per part of cementitious material.

**Okaloosa County TDC – Destin Fort Walton Beach Convention Center
Exterior Accessibility**

2. Masonry Cement Mix: Use 1 part masonry cement and 2-1/2 to 4 parts aggregate.
 3. Portland and Masonry Cement Mix: For cementitious material, mix 1 part portland cement and 1 part masonry cement. Use 2-1/2 to 4 parts aggregate per part of cementitious material.
 4. Plastic Cement Mix: Use 1 part plastic cement and 2-1/2 to 4 parts aggregate.
- E. Job-Mixed Finish-Coat Mixes:
1. Portland Cement Mix: For cementitious materials, mix 1 part portland cement and 1-1/2 to 2 parts lime. Use 1-1/2 to 3 parts aggregate per part of cementitious material.
 2. Masonry Cement Mix: Use 1 part masonry cement and 1-1/2 to 3 parts aggregate.
 3. Portland and Masonry Cement Mix: For cementitious materials, mix 1 part portland cement and 1 part masonry cement. Use 1-1/2 to 3 parts aggregate per part of cementitious material.
 4. Plastic Cement Mix: Use 1 part plastic cement and 1-1/2 to 3 parts aggregate.
- F. Factory-Prepared Finish-Coat Mixes: For ready-mixed finish-coat plasters, comply with manufacturer's written instructions.

PART 3 - EXECUTION

3.1 INSTALLATION, GENERAL

- A. Prepare smooth, solid substrates for plaster according to ASTM C926.
- B. Fire-Resistance-Rated Assemblies: Install components according to requirements for design designations from listing organization and publication indicated on Drawings.

3.2 INSTALLING METAL LATH

- A. Metal Lath: Install according to ASTM C1063.

3.3 INSTALLING ACCESSORIES

- A. Install according to ASTM C1063 and at locations indicated on Drawings.
- B. Reinforcement for External (Outside) Corners:
 1. Install lath-type, external-corner reinforcement at exterior locations.
 2. Install cornerbead at interior locations.
- C. Control Joints: Locate as indicated on Drawings.

**Okaloosa County TDC – Destin Fort Walton Beach Convention Center
Exterior Accessibility**

3.4 PLASTER APPLICATION

- A. General: Comply with ASTM C926.
- B. Bonding Compound: Apply on unit masonry and concrete substrates for direct application of plaster.
- C. Walls; Base-Coat Mixes for Use over Metal Lath: For scratch and brown coats, for three-coat plasterwork with **3/4-inch (19-mm)** total thickness, as follows:
 - 1. Portland cement mixes.
 - 2. Masonry cement mixes.
 - 3. Portland and masonry cement mixes.
 - 4. Plastic cement mixes.
 - 5. Portland and plastic cement mixes.
- D. Ceilings; Base-Coat Mixes for Use over Metal Lath: For scratch and brown coats, for three-coat plasterwork and having **3/4-inch (19-mm)** total thickness for metal lath on concrete, as follows:
 - 1. Portland cement mixes.
 - 2. Masonry cement mixes.
 - 3. Portland and masonry cement mixes.
 - 4. Plastic cement mixes.
 - 5. Portland and plastic cement mixes.
- E. Walls; Base-Coat Mix: For base (scratch) coat, for two-coat plasterwork and having **3/8-inch (10-mm)** thickness on masonry and **1/4-inch (6-mm)** thickness on concrete, as follows:
 - 1. Portland cement mix.
 - 2. Masonry cement mix.
 - 3. Portland and masonry cement mix.
 - 4. Plastic cement mix.
 - 5. Portland and plastic cement mix.
- F. Ceilings; Base-Coat Mix: For base (scratch) coat, for two-coat plasterwork and having **1/4-inch (6-mm)** thickness on concrete, as follows:
 - 1. Portland cement mix.
 - 2. Masonry cement mix.
 - 3. Portland and masonry cement mix.
 - 4. Plastic cement mix.
 - 5. Portland and plastic cement mix.
- G. Plaster Finish Coats: Apply to provide float finish to match Architect's sample.
- H. Acrylic-Based Finish Coatings: Apply coating system, including primers, finish coats, and sealing topcoats, according to manufacturer's written instructions.

**Okaloosa County TDC – Destin Fort Walton Beach Convention Center
Exterior Accessibility**

- I. Concealed Exterior Plasterwork: Where plaster application is used as a base for adhered finishes, omit finish coat.

- J. Concealed Interior Plasterwork:
 - 1. Where plaster application is concealed behind built-in cabinets, similar furnishings, and equipment, apply finish coat.
 - 2. Where plaster application is concealed above suspended ceilings and in similar locations, omit finish coat.
 - 3. Where plaster application is used as a base for adhesive application of tile and similar finishes, omit finish coat.

3.5 PLASTER REPAIRS

- A. Repair or replace work to eliminate cracks, dents, blisters, buckles, crazing and check cracking, dry outs, efflorescence, sweat outs, and similar defects and where bond to substrate has failed.

END OF SECTION 092400

**Okaloosa County TDC – Destin Fort Walton Beach Convention Center
Exterior Accessibility**

Page Left Blank

**Okaloosa County TDC – Destin Fort Walton Beach Convention Center
Exterior Accessibility**

SECTION 092900 - GYPSUM BOARD

PART 1 - GENERAL

1.1 SUMMARY

A. Section Includes:

1. Interior gypsum board.

1.2 ACTION SUBMITTALS

- A. Product Data: For each type of product.

PART 2 - PRODUCTS

2.1 GYPSUM BOARD, GENERAL

- A. Size: Provide maximum lengths and widths available that will minimize joints in each area and that correspond with support system indicated.

2.2 INTERIOR GYPSUM BOARD

- A. Gypsum Board, Type X: ASTM C1396/C1396M.
 1. Thickness: 5/8 inch (15.9 mm).
 2. Long Edges: Tapered and featured (rounded or beveled) for prefilling.
- B. Mold-Resistant Gypsum Board: ASTM C1396/C1396M. With moisture- and mold-resistant core and paper surfaces.
 1. Core: 5/8 inch (15.9 mm), Type X]
 2. Long Edges: Tapered.
 3. Mold Resistance: ASTM D3273, score of 10 as rated according to ASTM D3274.

2.3 TRIM ACCESSORIES

- A. Interior Trim: ASTM C1047.
 1. Material: Galvanized or aluminum-coated steel sheet, rolled zinc, plastic, or paper-faced galvanized-steel sheet.
 2. Shapes:
 - a. LC-Bead: J-shaped; exposed long flange receives joint compound.
 - b. L-Bead: L-shaped; exposed long flange receives joint compound.

**Okaloosa County TDC – Destin Fort Walton Beach Convention Center
Exterior Accessibility**

- c. U-Bead: J-shaped; exposed short flange does not receive joint compound.
- d. Expansion (control) joint.

2.4 JOINT TREATMENT MATERIALS

- A. General: Comply with ASTM C475/C475M.
- B. Joint Tape:
 - 1. Interior Gypsum Board: Paper.
 - 2. Glass-Mat Gypsum Sheathing Board: 10-by-10 glass mesh.
 - 3. Tile Backing Panels: As recommended by panel manufacturer.
- C. Joint Compound for Interior Gypsum Board: For each coat, use formulation that is compatible with other compounds applied on previous or for successive coats.
 - 1. Prefilling: At open joints and damaged surface areas, use setting-type taping compound.
 - 2. Embedding and First Coat: For embedding tape and first coat on joints, fasteners, and trim flanges, use drying-type, all-purpose compound.
 - a. Use setting-type compound for installing paper-faced metal trim accessories.
 - 3. Fill Coat: For second coat, use drying-type, all-purpose compound.
 - 4. Finish Coat: For third coat, use drying-type, all-purpose compound.
 - 5. Skim Coat: For final coat of Level 5 finish, use drying-type, all-purpose compound.
- D. Joint Compound for Tile Backing Panels:
 - 1. Glass-Mat, Water-Resistant Backing Panel: As recommended by backing panel manufacturer.

2.5 AUXILIARY MATERIALS

- A. General: Provide auxiliary materials that comply with referenced installation standards and manufacturer's written instructions.
- B. Laminating Adhesive: Adhesive or joint compound recommended for directly adhering gypsum panels to continuous substrate.
- C. Steel Drill Screws: ASTM C1002 unless otherwise indicated.
 - 1. Use screws complying with ASTM C954 for fastening panels to steel members from 0.033 to 0.112 inch (0.84 to 2.84 mm) thick.
 - 2. For fastening cementitious backer units, use screws of type and size recommended by panel manufacturer.
- D. Thermal Insulation: As specified in Section 072100 "Thermal Insulation."

**Okaloosa County TDC – Destin Fort Walton Beach Convention Center
Exterior Accessibility**

PART 3 - EXECUTION**3.1 APPLYING AND FINISHING PANELS**

- A. Examine panels before installation. Reject panels that are wet, moisture damaged, and mold damaged.
- B. Comply with ASTM C840.
- C. Isolate perimeter of gypsum board applied to non-load-bearing partitions at structural abutments. Provide 1/4- to 1/2-inch- (6.4- to 12.7-mm-) wide spaces at these locations and trim edges with edge trim where edges of panels are exposed. Seal joints between edges and abutting structural surfaces with acoustical sealant.
- D. For trim with back flanges intended for fasteners, attach to framing with same fasteners used for panels. Otherwise, attach trim according to manufacturer's written instructions.
- E. Prefill open joints and damaged surface areas.
- F. Apply joint tape over gypsum board joints, except for trim products specifically indicated as not intended to receive tape.
- G. Gypsum Board Finish Levels: Finish panels to levels indicated below and according to ASTM C840:
 - 1. Level 1: Ceiling plenum areas, concealed areas.
 - 2. Level 2: Panels that are substrate for tile.
 - 3. Level 5: Exposed walls.
- H. Glass-Mat Faced Panels: Finish according to manufacturer's written instructions.
- I. Cementitious Backer Units: Finish according to manufacturer's written instructions.

3.2 PROTECTION

- A. Protect installed products from damage from weather, condensation, direct sunlight, construction, and other causes during remainder of the construction period.
- B. Remove and replace panels that are wet, moisture damaged, and mold damaged.

END OF SECTION 092900

**Okaloosa County TDC – Destin Fort Walton Beach Convention Center
Exterior Accessibility**

Page Left Blank

**Okaloosa County TDC – Destin Fort Walton Beach Convention Center
Exterior Accessibility**

SECTION 096813 - TILE CARPETING

PART 1 - GENERAL

1.1 SUMMARY

A. Section Includes:

1. Modular carpet tile.

1.2 PREINSTALLATION MEETINGS

- A. Preinstallation Conference: Conduct conference at Project site.

1.3 ACTION SUBMITTALS

- A. Product Data: For each type of product.
- B. Samples: For each exposed product and for each color and texture required.

1.4 INFORMATIONAL SUBMITTALS

- A. Product test reports.
- B. Sample warranty.

1.5 CLOSEOUT SUBMITTALS

- A. Maintenance data.

1.6 QUALITY ASSURANCE

- A. Installer Qualifications: Certified by the International Certified Floorcovering Installers Association at the Commercial II certification level.

1.7 WARRANTY

- A. Special Warranty for Carpet Tiles: Manufacturer agrees to repair or replace components of carpet tile installation that fail in materials or workmanship within specified warranty period.

1. Warranty Period: 10 years from date of Substantial Completion.

**Okaloosa County TDC – Destin Fort Walton Beach Convention Center
Exterior Accessibility**

PART 2 - PRODUCTS**2.1 CARPET TILE**

- A. Tarkett – Assertive Stria 04839
- B. Color: As selected by Architect from manufacturer's full range.
- C. Pattern: Linear
- D. Format Type; Tile
- E. Surface Treatment: Eco-Ensure (Fluorine-Free Soil Protection
- F. Total Thickness: 0.245” (6.27 mm)
- G. Installation Method: Glue-Down
- H. Primary Backing: Synthetic Non-Woven
- I. Secondary Backing: Modular ethos with Omnicoat Technology.
- J. Face Weight: 28 oz/yd
- K. Pile Thickness: 0.110” (2.79 mm)
- L. Size: 24 by 24 inches (610 by 610 mm).
- M. Applied Treatments:
 - 1. Soil-Resistance Treatment: Manufacturer's standard treatment.
 - 2. Antimicrobial Treatment: Manufacturer's standard treatment that protects carpet tiles as follows:
 - a. Antimicrobial Activity: Not less than 2-mm halo of inhibition for gram-positive bacteria, not less than 1-mm halo of inhibition for gram-negative bacteria, and no fungal growth, according to AATCC 174.

2.2 INSTALLATION ACCESSORIES

- A. Trowelable Leveling and Patching Compounds: Latex-modified, hydraulic-cement-based formulation provided or recommended by carpet tile manufacturer.
- B. Adhesives: Water-resistant, mildew-resistant, nonstaining, pressure-sensitive type to suit products and subfloor conditions indicated, that comply with flammability requirements for installed carpet tile, and are recommended by carpet tile manufacturer for releasable installation.

**Okaloosa County TDC – Destin Fort Walton Beach Convention Center
Exterior Accessibility**

PART 3 - EXECUTION

3.1 EXAMINATION

A. Concrete Slabs:

1. **Moisture Testing:** Perform tests so that each test area does not exceed 200 sq. ft. (18.6 sq. m), and perform no fewer than three tests in each installation area and with test areas evenly spaced in installation areas.
 - a. **Anhydrous Calcium Chloride Test:** ASTM F1869. Proceed with installation only after substrates have maximum moisture-vapor-emission rate of 3 lb of water/1000 sq. ft. (1.36 kg of water/92.9 sq. m) in 24 hours.
 - b. **Relative Humidity Test:** Using in situ probes, ASTM F2170. Proceed with installation only after substrates have a maximum 75 percent relative humidity level measurement.
 - c. Perform additional moisture tests recommended in writing by adhesive and carpet tile manufacturers. Proceed with installation only after substrates pass testing.

3.2 PREPARATION

- A. **General:** Comply with the Carpet and Rug Institute's CRI 104 and with carpet tile manufacturer's written installation instructions for preparing substrates indicated to receive carpet tile.
- B. Use trowelable leveling and patching compounds, according to manufacturer's written instructions, to fill cracks, holes, depressions, and protrusions in substrates. Fill or level cracks, holes and depressions 1/8 inch (3 mm) wide or wider, and protrusions more than 1/32 inch (0.8 mm) unless more stringent requirements are required by manufacturer's written instructions.
- C. **Concrete Substrates:** Remove coatings, including curing compounds, and other substances that are incompatible with adhesives and that contain soap, wax, oil, or silicone, without using solvents. Use mechanical methods recommended in writing by adhesive and carpet tile manufacturers.
- D. Broom and vacuum clean substrates to be covered immediately before installing carpet tile.

3.3 INSTALLATION

- A. **General:** Comply with the Carpet and Rug Institute's CRI 104, Section 10, "Carpet Tile," and with carpet tile manufacturer's written installation instructions.
- B. **Installation Method:** As recommended in writing by carpet tile manufacturer.
- C. **Maintain dye-lot integrity.** Do not mix dye lots in same area.

**Okaloosa County TDC – Destin Fort Walton Beach Convention Center
Exterior Accessibility**

- D. Maintain pile-direction patterns recommended in writing by carpet tile manufacturer.
- E. Cut and fit carpet tile to butt tightly to vertical surfaces, permanent fixtures, and built-in furniture including cabinets, pipes, outlets, edgings, thresholds, and nosings. Bind or seal cut edges as recommended by carpet tile manufacturer.
- F. Extend carpet tile into toe spaces, door reveals, closets, open-bottomed obstructions, removable flanges, alcoves, and similar openings.
- G. Install pattern parallel to walls and borders.
- H. Protect carpet tile against damage from construction operations and placement of equipment and fixtures during the remainder of construction period. Use protection methods indicated or recommended in writing by carpet tile manufacturer.

END OF SECTION 096813

**Okaloosa County TDC – Destin Fort Walton Beach Convention Center
Exterior Accessibility**

SECTION 099113 - EXTERIOR PAINTING

PART 1 - GENERAL

1.1 SUMMARY

- A. Section includes surface preparation and the application of paint systems on exterior substrates.

1.2 DEFINITIONS

- A. MPI Gloss Level 1: Not more than five units at 60 degrees and 10 units at 85 degrees, according to ASTM D523.
- B. MPI Gloss Level 3: 10 to 25 units at 60 degrees and 10 to 35 units at 85 degrees, according to ASTM D523.
- C. MPI Gloss Level 4: 20 to 35 units at 60 degrees and not less than 35 units at 85 degrees, according to ASTM D523.
- D. MPI Gloss Level 5: 35 to 70 units at 60 degrees, according to ASTM D523.
- E. MPI Gloss Level 6: 70 to 85 units at 60 degrees, according to ASTM D523.
- F. MPI Gloss Level 7: More than 85 units at 60 degrees, according to ASTM D523.

1.3 ACTION SUBMITTALS

- A. Product Data: For each type of product. Include preparation requirements and application instructions.
 - 1. Include printout of current "MPI Approved Products List" for each product category specified, with the proposed product highlighted.
- B. Samples: For each type of paint system and each color and gloss of topcoat.

1.4 QUALITY ASSURANCE

- A. Mockups: Apply mockups of each paint system indicated and each color and finish selected to verify preliminary selections made under Sample submittals and to demonstrate aesthetic effects and set quality standards for materials and execution.
 - 1. Architect will select one surface to represent surfaces and conditions for application of each paint system.

**Okaloosa County TDC – Destin Fort Walton Beach Convention Center
Exterior Accessibility**

- a. Vertical and Horizontal Surfaces: Provide samples of at least 100 sq. ft. (9 sq. m).
 - b. Other Items: Architect will designate items or areas required.
2. Final approval of color selections will be based on mockups.
 - a. If preliminary color selections are not approved, apply additional mockups of additional colors selected by Architect at no added cost to Owner.

PART 2 - PRODUCTS

2.1 PAINT, GENERAL

- A. MPI Standards: Products shall comply with MPI standards and shall be listed in its "MPI Approved Products Lists."
- B. Material Compatibility:
 1. Materials for use within each paint system shall be compatible with one another and substrates indicated, under conditions of service and application as demonstrated by manufacturer, based on testing and field experience.
 2. For each coat in a paint system, products shall be recommended in writing by topcoat manufacturers for use in paint system and on substrate indicated.
- C. Colors: As selected by Architect from manufacturer's full range.

PART 3 - EXECUTION

3.1 EXAMINATION

- A. Examine substrates and conditions, with Applicator present, for compliance with requirements for maximum moisture content and other conditions affecting performance of the Work.
- B. Maximum Moisture Content of Substrates: When measured with an electronic moisture meter as follows:
 1. Concrete: 12 percent.
 2. Fiber-Cement Board: 12 percent.
 3. Masonry (Clay and CMUs): 12 percent.
 4. Wood: 15 percent.
 5. Portland Cement Plaster: 12 percent.
 6. Gypsum Board: 12 percent.
- C. Verify suitability of substrates, including surface conditions and compatibility with existing finishes and primers.
- D. Proceed with coating application only after unsatisfactory conditions have been corrected.

**Okaloosa County TDC – Destin Fort Walton Beach Convention Center
Exterior Accessibility**

1. Application of coating indicates acceptance of surfaces and conditions.

3.2 PREPARATION

- A. Comply with manufacturer's written instructions and recommendations in "MPI Architectural Painting Specification Manual" applicable to substrates and paint systems indicated.
- B. Remove hardware, covers, plates, and similar items already in place that are removable and are not to be painted. If removal is impractical or impossible because of size or weight of item, provide surface-applied protection before surface preparation and painting.
 1. After completing painting operations, use workers skilled in the trades involved to reinstall items that were removed. Remove surface-applied protection.

3.3 APPLICATION

- A. Apply paints according to manufacturer's written instructions and recommendations in "MPI Manual."
- B. Apply paints to produce surface films without cloudiness, spotting, holidays, laps, brush marks, roller tracking, runs, sags, ropiness, or other surface imperfections. Cut in sharp lines and color breaks.

3.4 CLEANING AND PROTECTION

- A. Protect work of other trades against damage from paint application. Correct damage to work of other trades by cleaning, repairing, replacing, and refinishing, as approved by Architect, and leave in an undamaged condition.
- B. At completion of construction activities of other trades, touch up and restore damaged or defaced painted surfaces.

PART 4 - SCHEDULE

4.1 WALL SCHEDULE

- A. Slab exposed edges, face and tops of walls.
 1. Sherwin Williams Loxon primer and Loxon XP elastomeric coating applied at a rate of 16 dry film mils.
 - a. Colors to match existing and coordinated with Owner.
 - 1) SW 6254 Lazy Gray
 - 2) SW 7664 Steely Gray
 - 3) SW 6487 Cloud Burst
 - 4) SW 6775 Briny

**Okaloosa County TDC – Destin Fort Walton Beach Convention Center
Exterior Accessibility**

END OF SECTION 099113

Page Left Blank

**Okaloosa County TDC – Destin Fort Walton Beach Convention Center
Exterior Accessibility**

SECTION 099123 - INTERIOR PAINTING

PART 1 - GENERAL

1.1 SUMMARY

- A. This Section includes surface preparation and the application of paint systems on the following interior substrates:
1. Concrete masonry units (CMU).
 2. Steel.
 3. Galvanized metal.
 4. Gypsum board.

1.2 SUBMITTALS

- A. Product Data: For each type of product indicated.
- B. Samples: For each finish and for each color and texture required.
1. Submit samples on rigid backing, 8-inches (200 mm) square.
 2. Step coats on samples to show each coat required for system.
 3. Label each coat of each sample.
 4. Label each sample for location and application area.
- C. Product List: Printout of current "MPI Approved Products List" for each product category specified in Part 2, with the proposed product highlighted.

1.3 QUALITY ASSURANCE

- A. Applicator Qualifications: A firm or individual experienced in applying paints and coatings similar in material, design and extent to those indicated for this Project, whose work has resulted in applications with a record of successful in-service performance.
- B. Source Limitations: Obtain block filler and primers for each coating system from the same manufacturer as the finish coats.
- C. MPI Standards:
1. Products: Complying with MPI standards indicated and listed in "MPI Approved Products List."
 2. Preparation and Workmanship: Comply with requirements in "MPI Architectural Painting Specification Manual" for products and paint systems indicated.
- D. Mockups: Apply benchmark samples of each paint system indicated and each color and finish selected to verify preliminary selections made under sample submittals and to demonstrate aesthetic effects and set quality standards for materials and execution.
1. Architect will select one surface to represent surfaces and conditions for application of each paint system specified in Part 3.
 - a. Wall and Ceiling Surfaces: Provide samples of at least 100 sq. ft. (9 sq. m).
 - b. Other Items: Architect will designate items or areas required.
 2. Apply benchmark samples after permanent lighting and other environmental services have been activated.
 3. Final approval of color selections will be based on benchmark samples.
 - a. If preliminary color selections are not approved, apply additional benchmark samples of additional colors selected by Architect at no added cost to Owner.

**Okaloosa County TDC – Destin Fort Walton Beach Convention Center
Exterior Accessibility**

1.4 EXTRA MATERIALS

- A. Furnish extra materials described below that are from same production run (batch mix) as materials applied and that are packaged for storage and identified with labels describing contents.
 - 1. Quantity: Furnish an additional 5 percent, but not less than 1 gal. (3.8 L) of each material and color applied.

PART 2 - PRODUCTS

2.1 PAINT, GENERAL

- A. Material Compatibility:
 - 1. Provide materials for use within each paint system that are compatible with one another and substrates indicated, under conditions of service and application as demonstrated by manufacturer, based on testing and field experience.
 - 2. For each coat in a paint system, provide products recommended in writing by manufacturers of topcoat for use in paint system and on substrate indicated.
- B. Colors: As selected by Architect from manufacturer's full range.

2.2 BLOCK FILLERS

- A. Interior/Exterior Latex Block Filler: MPI #4.
 - 1. Epoxy Block Filler: MPI #116.

2.3 PRIMERS/SEALERS

- A. Interior Latex Primer/Sealer: MPI #50.

2.4 METAL PRIMERS

- A. Quick-Drying Alkyd Metal Primer: MPI #76.
- B. Waterborne Galvanized-Metal Primer: MPI #134.

2.5 LATEX PAINTS

- A. Interior Latex (Flat): MPI #53 (Gloss Level 1).
- B. Interior Latex (Satin): MPI #43 (Gloss Level 4).
- C. Interior Latex (Semigloss): MPI #54 (Gloss Level 5).

2.6 SOLVENT-BASED PAINTS

- A. Quick Dry (semigloss) MPI #81 (Gloss Level 5)

2.7 EPOXY PAINTS

- A. Epoxy cold cured gloss: MPI #77 (gloss level 5).

**Okaloosa County TDC – Destin Fort Walton Beach Convention Center
Exterior Accessibility**

2.8 FLOOR COATINGS

- A. Interior/Exterior Clear Concrete Floor Sealer (Water Based): MPI #99.

PART 3 - EXECUTION

3.1 EXAMINATION

- A. Examine substrates and conditions, with Applicator present, for compliance with requirements for maximum moisture content and other conditions affecting performance of work.
- B. Maximum Moisture Content of Substrates: When measured with an electronic moisture meter as follows:
1. Concrete: 12 percent.
 2. Masonry (Clay and CMU): 12 percent.
 3. Gypsum Board: 12 percent.
- C. Verify suitability of substrates, including surface conditions and compatibility with existing finishes and primers.
- D. Begin coating application only after unsatisfactory conditions have been corrected and surfaces are dry.
1. Beginning coating application constitutes Contractor's acceptance of substrates and conditions.

3.2 PREPARATION AND APPLICATION

- A. Comply with manufacturer's written instructions and recommendations in "MPI Architectural Painting Specification Manual" applicable to substrates indicated.
- B. Remove plates, machined surfaces, and similar items already in place that are not to be painted. If removal is impractical or impossible because of size or weight of item, provide surface-applied protection before surface preparation and painting.
1. After completing painting operations, use workers skilled in the trades involved to reinstall items that were removed. Remove surface-applied protection if any.
 2. Do not paint over labels of independent testing agencies or equipment name, identification, performance rating, or nomenclature plates.
- C. Concrete Substrates: Remove release agents, curing compounds, efflorescence and chalk. Do not paint surfaces if moisture content or alkalinity of surfaces to be painted exceeds that permitted in manufacturer's written instructions.
1. Clean concrete floors to be painted with a 5 percent solution of muriatic acid or other etching cleaner. Flush the floor with clean water to remove acid, neutralize with ammonia, rinse, allow to dry and vacuum before painting.
- D. Concrete Masonry Substrates: Remove efflorescence and chalk. Do not paint surfaces if moisture content or alkalinity of surfaces to be painted exceeds that permitted in manufacturer's written instructions.
- E. Steel Substrates: Remove rust and loose mill scale. Clean using methods recommended in writing by paint manufacturer.
1. Treat bare and sandblasted or pickled clean metal with a metal treatment wash coat before priming.

**Okaloosa County TDC – Destin Fort Walton Beach Convention Center
Exterior Accessibility**

2. Touch up bare areas and shop-applied prime coats that have been damaged. Wire brush, clean with solvents recommended by paint manufacturer, and tough up with same primer as the shop coat.
- F. Galvanized-Metal Substrates: Remove grease and oil residue from galvanized sheet metal fabricated from coil stock by mechanical methods to produce clean, lightly etched surfaces that promise adhesion of subsequently applied paints.
- G. Aluminum Substrates: Remove surface oxidation.
- H. Gypsum Board Substrates: Do not begin paint application until finishing compound is dry and sanded smooth.
- I. Clean substrates of substances that could impair bond of paints, including dirt, oil, grease, and incompatible paints and encapsulants.
1. Remove incompatible primers and reprime substrate with compatible primers as required to produce paint systems indicated.
- J. Apply paints according to manufacturer's written instructions.
1. Use applicators and techniques suited for paint and substrate indicated.
 2. Paint surfaces behind movable equipment and furniture same as similar exposed surfaces. Before final installation, paint surfaces behind permanently fixed equipment or furniture with prime coat only.
 3. Paint front and backsides of access panels, removable or hinged covers, and similar hinged items to match exposed surfaces.
 4. Do not paint over dirt, rust, scale, grease, moisture, scuffed surfaces, or conditions detrimental to formation of durable paint film.
 5. Provide finish coats that are compatible with primers used.
 6. The term "exposed surfaces" includes areas visible when permanent or built-in-fixtures, grilles, convector covers, covers for finned-tube radiation, and similar components are in place. Extend coatings in these areas, as required, to maintain system integrity and provide desired protection.
 7. Paint interior surfaces of ducts with a flat, nonspecular black paint where visible through registers or grilles.
 8. Finish interior of wall and base cabinets and similar field-finished casework to match exterior.
 9. Sand lightly between each succeeding enamel or varnish coat.
- K. Apply paints to produce surface films without cloudiness, spotting, holidays, laps, brush marks, roller tracking, runs, sags, ropiness, or other surface imperfections. Cut in sharp lines and color breaks.
- L. Painting Steel, Mechanical and Electrical Work: Paint items exposed, but not limited to the following:
1. Steel Work:
 - a. Exposed beams, columns, purlins, girts.
 - b. Exposed metal decking
 - c. Handrails, Guardrails, Risers, Stringers not scheduled to be galvanized.
 - d. Exposed miscellaneous fasteners, plates, angles
 - e. Other elements exposed to finished interior areas.
 2. Mechanical Work:
 - a. Uninsulated metal piping.
 - b. Uninsulated plastic piping.
 - c. Pipe hangers and supports.
 - d. Tanks that do not have factory-applied final finishes.

**Okaloosa County TDC – Destin Fort Walton Beach Convention Center
Exterior Accessibility**

- e. Visible portions of internal surfaces of metal ducts, without liner, behind air inlets and outlets.
- f. Duct, equipment, and pipe insulation having cotton or canvas insulation covering or other paintable jacket material.
- g. Mechanical equipment that is indicated to have a factory-primed finish for field painting.
- h. Fire Sprinkler piping and components.
- 3. Electrical Work:
 - a. Switchgear.
 - b. Panelboards.
 - c. Electrical equipment that is indicated to have a factory-primed finish for field painting.
 - d. Exposed conduit and boxes
- M. Protect work of other trades against damage from paint application. Correct damage to work of other trades by cleaning, repairing, replacing, and refinishing, as approved by Architect, and leave in an undamaged condition.
- N. Provide “Wet Paint” signs to protect newly painted finishes. After completing painting operations, remove temporary protective wrappings provided by others to protect their work.
- O. At completion of construction activities of other trades, touch up and restore damaged or defaced painted surfaces.

3.3 INTERIOR PAINTING SCHEDULE

- A. CMU Substrates:
 - 1. Latex System: MPI INT 4.2A.
 - a. Prime Coat: Interior/exterior latex block filler.
 - b. Intermediate Coat: Interior latex matching topcoat.
 - c. Topcoat: Interior latex (satin).
 - 2. Epoxy System: MPI INT 4.2G.
 - a. Prime Coat: Epoxy block filler.
 - b. Intermediate Coat: Epoxy cold cured gloss matching topcoat.
 - c. Topcoat: Epoxy cold cured (gloss).
- B. Steel Substrates:
 - 1. Alkyd Gloss Finish: MPI INT 5.1E.
 - a. Prime Coat: Quick-drying alkyd metal primer.
 - b. Intermediate Coat: Alkyd matching topcoat.
 - c. Topcoat: Alkyd (semigloss).
- C. Galvanized-Metal Substrates:
 - 1. Alkyd System: MPI INT 5.3L.
 - a. Prime Coat: Waterborne galvanized-metal primer.
 - b. Intermediate Coat: Alkyd matching topcoat.
 - c. Topcoat: Alkyd (semigloss).
- D. Gypsum Board Substrates:
 - 1. Latex System: MPI INT 9.2A.
 - a. Prime Coat: Interior latex primer/sealer.
 - b. Intermediate Coat: Interior latex matching topcoat.

**Okaloosa County TDC – Destin Fort Walton Beach Convention Center
Exterior Accessibility**

- c. Topcoat: Interior latex (flat) at ceiling applications and (Satin) at wall applications.
 - 2. Epoxy System: MPI INT 9.2F.
 - a. Prime Coat: Interior latex primer/sealer.
 - b. Intermediate Coat: Epoxy cold cured gloss matching topcoat.
 - c. Topcoat: Epoxy cold cured gloss.
- E. Interior Concrete Substrates:
 - 1. Epoxy System: MPI 98.
 - a. Tile-Clad High Solids epoxy polyamide coating.

END OF SECTION 099123

**Okaloosa County TDC – Destin Fort Walton Beach Convention Center
Exterior Accessibility**

SECTION 131154 – FOUNTAIN TILE

PART 1 - GENERAL

1.1 RELATED DOCUMENTS

- A. Drawings and general provisions of the Contract, including General and Supplementary Conditions and Division 01 Specification Sections, apply to this Section.

1.2 SUMMARY

- A. Section Includes:
 - 1. Fountain Tile.
 - 2. Setting Materials
 - 3. Grout

1.3 ACTION SUBMITTALS

- A. Product Data: For materials, grout and setting beds.
- B. Samples: For each type of tile.

1.4 INFORMATIONAL SUBMITTALS

- A. Material Certificates: Include statements of material properties indicating compliance with requirements, including compliance with standards.

1.5 QUALITY ASSURANCE

- A. Installer Qualifications: Ceramic Tile Education Foundation Certified Installers or installers recognized by the U.S. Department of Labor as Journeyman Tile Layers.
- B. Manufacture of all tile shall be in accordance with ANSI A-137.1-2019.
- C. Install ceramic tile in accordance with the recommendations contained in 2020 Handbook for Ceramic, Glass, and Stone Tile Installation of the Tile Council of America; Inc.

1.6 FIELD CONDITIONS

- A. Cold-Weather Protection: Do not use frozen materials or materials mixed or coated with ice or frost. Do not build on frozen subgrade or setting beds. Remove and replace unit paver work damaged by frost or freezing.

**Okaloosa County TDC – Destin Fort Walton Beach Convention Center
Exterior Accessibility**

- B. Weather Limitations for Mortar.
1. Cold-Weather Requirements: Comply with cold-weather construction requirements contained in TMS 602/ACI 530.1/ASCE 6.
 2. Hot-Weather Requirements: Comply with hot-weather construction requirements contained in TMS 602/ACI 530.1/ASCE 6. Provide artificial shade and windbreaks and use cooled materials as required. Do not apply mortar to substrates with temperatures of 100 deg F (38 deg C) and higher.

1.7 PRODUCT HANDLING

- A. Delivery: Deliver materials to the Project Site in the manufacturer's original unopened containers with all labels intact and legible.
- B. Storage: Store materials under cover in a manner to prevent damage and contamination, and store only the specified materials at the Project Site.
- C. Protection: Use all means necessary to protect swimming pool ceramic tile before, during and after installation and to protect the installed Work of all other trades.
- D. Replacements: In the event of damage, immediately make all repairs and replacements necessary to the approval of the Owner's Representative.

PART 2 - PRODUCTS

2.1 TILE

- A. Basis of Design, NPT Building Materials
1. Face Size and Shape:
 - a. Wall Tile & Basins – 6” X 12” Slate Ash.
 - b. Wall Sunburst Pattern – Consists of 6” X 6” Element, 3” X 3” Harmony, 1” X 1” Lightwaves & 4” X 12” Slate Ash (Cut to match radius)
 - c. Step Tread – 6” X 6” Martinique Royal Blue Bullnose .
 - d. Step Riser – 6”X 6” Martinique Royal Blue
 2. Color: As selected by Architect from manufacturer's full range.

2.2 MORTAR

- A. Sand for Mortar: Comply with requirements of fine aggregate for concrete.
- B. Cement: Type I Portland Cement, conforming to ASTM C150.
- C. Hydrated Lime: Conforming to ASTM C206 or 207, Type S.
- D. Water: From a potable source.

**Okaloosa County TDC – Destin Fort Walton Beach Convention Center
Exterior Accessibility**

2.3 GROUT

- A. All tile grout shall be waterproof grout complying with the recommendations of referenced standards. Grout color shall be grey for dark backgrounds, white for light backgrounds (verify colors with Owner).

2.4 OTHER MATERIALS

- A. All other materials, not specifically described but required for a complete and proper installation of ceramic tile as indicated on the Drawings, shall be new, first quality of their respective kinds, and subject to the approval of the Designated Representative.

PART 3 - EXECUTION

3.1 SURFACE CONDITIONS

- A. Inspection:
 - 1. Prior to Work of this Section, carefully inspect the installed Work of other trades and verify that all such Work is complete to the point where this installation can properly commence.
 - 2. Verify that tile can be installed in accordance with the original design and all referenced standards.
- B. Discrepancies:
 - 1. In the event of discrepancy, immediately notify the Owner's Representative.
 - 2. Do not proceed with installation in areas of discrepancy until all such discrepancies have been fully resolved.
 - 3. Failure to notify the Owner's Representative and give written notice of discrepancies shall constitute acceptance by the Contractor of existing conditions as fit and proper to receive the Work.

3.2 GROUTING.

- A. Follow grout manufacturer's recommendations as to grouting procedures and precautions.
- B. Remove all grout haze, observing grout manufacturer's recommendations as to use of acid and chemical cleaners.

3.3 CLEAN UP

- A. Upon completion of the swimming pool ceramic tile installation, thoroughly clean and polish the exposed surfaces of tile work. Completely clean work area of debris and rubbish occasioned by this Work and dispose of to the approval of the Designated Representative.

**Okaloosa County TDC – Destin Fort Walton Beach Convention Center
Exterior Accessibility**

- B. Provide the Owner with 10% extra stock of tile in the size and colors used.

END OF SECTION 131154

**Okaloosa County TDC – Destin Fort Walton Beach Convention Center
Exterior Accessibility**

SECTION 321400 - UNIT PAVING

PART 1 - GENERAL

1.1 RELATED DOCUMENTS

- A. Drawings and general provisions of the Contract, including General and Supplementary Conditions and Division 01 Specification Sections, apply to this Section.

1.2 SUMMARY

- A. Section Includes:
 - 1. Concrete pavers.
 - 2. Detectable Warning Pavers

1.3 ACTION SUBMITTALS

- A. Product Data: For materials other than water and aggregates.
- B. Samples: For each type of unit paver indicated.

1.4 INFORMATIONAL SUBMITTALS

- A. Material Certificates: For unit pavers. Include statements of material properties indicating compliance with requirements, including compliance with standards. Provide for each type and size of unit.

1.5 QUALITY ASSURANCE

- A. Installer Qualifications: A qualified unit paving installer. Installer's field supervisor shall have Concrete Paver Installer Certification from the Interlocking Concrete Pavement Institute (ICPI) with the following designation:
 - 1. Commercial Paver Technician Designation.

1.6 FIELD CONDITIONS

- A. Cold-Weather Protection: Do not use frozen materials or materials mixed or coated with ice or frost. Do not build on frozen subgrade or setting beds. Remove and replace unit paver work damaged by frost or freezing.
- B. Weather Limitations for Mortar.

**Okaloosa County TDC – Destin Fort Walton Beach Convention Center
Exterior Accessibility**

1. Cold-Weather Requirements: Comply with cold-weather construction requirements contained in TMS 602/ACI 530.1/ASCE 6.
2. Hot-Weather Requirements: Comply with hot-weather construction requirements contained in TMS 602/ACI 530.1/ASCE 6. Provide artificial shade and windbreaks and use cooled materials as required. Do not apply mortar to substrates with temperatures of 100 deg F (38 deg C) and higher.

PART 2 - PRODUCTS

2.1 CONCRETE PAVERS

- A. Artistic Pavers – STEPLOCK Pavers – 120 NE 179th Street, North Miami Beach, FL 33162, 305-653-7511
- B. “A” Type Paver
 1. Thickness:
 - a. Pedestrian and Stairs - 1-5/8 inches (41 mm)
 2. Face Size and Shape:
 - a. Pedestrian - 12 inches (305 mm) by 24 inches (610 mm) Rectangle.
 - b. Stair Treads - 12 inches (305 mm) by 24 inches (610 mm) Single Sided Coping
 - c. Stair Risers – 5-3/8” inches (137 mm) by 24 inches (610 mm) Rectangle
 3. Paver Material: As selected by Architect from manufacturer's full range.
 - a. Shellock
 - b. Granitelock
 4. Color: As selected by Architect from manufacturer's full range.
- C. “B” Type Paver
 1. Thickness:
 - a. Roadways – 2-3/8” (60 mm)]
 2. Face Size and Shape:
 - a. Roadways - 8 inches (204 mm) by 12 inches (610 mm) Rectangle.
 3. Paver Material: As selected by Architect from manufacturer's full range.
 - a. Shellock
 - b. Granitelock
 4. Color: As selected by Architect from manufacturer's full range.

2.2 DETECTABLE WARNING PAVERS

1. Tile Tech Pavers Inc. ADA Detectable Warning Pavers
 - a. Color: Charcoal
 - b. Size: 12” x 12“ x 2” Nominal
 - c. Finish: Shot-blasted & Sealed:

**Okaloosa County TDC – Destin Fort Walton Beach Convention Center
Exterior Accessibility**

2.3 AGGREGATE SETTING-BED MATERIALS

- A. Sand for Leveling Course: Sound, sharp, washed, natural sand or crushed stone complying with gradation requirements in ASTM C33/C33M for fine aggregate.
- B. Sand for Joints: Fine, sharp, washed, natural sand or crushed stone with 100 percent passing No. 16 (1.18-mm) sieve and no more than 10 percent passing No. 200 (0.075-mm) sieve.
- C. Herbicide: Commercial chemical for weed control, registered with the EPA. Provide in granular, liquid, or wettable powder form.

2.4 MORTAR SETTING-BED MATERIALS

- A. Portland Cement: ASTM C150/C150M, Type I or Type II.
- B. Hydrated Lime: ASTM C207, Type S.
- C. Sand: ASTM C144.
- D. Latex Additive: Manufacturer's standard water emulsion, serving as replacement for part or all of gaging water, of type specifically recommended by latex-additive manufacturer for use with field-mixed portland cement and aggregate mortar bed, and not containing a retarder.
- E. Water: Potable.

PART 3 - EXECUTION

3.1 INSTALLATION, GENERAL

- A. Mix pavers from several pallets or cubes, as they are placed, to produce uniform blend of colors and textures.
- B. Cut unit pavers with motor-driven masonry saw equipment to provide clean, sharp, unchipped edges. Cut units to provide pattern indicated and to fit adjoining work neatly. Use full units without cutting where possible. Hammer cutting is not acceptable.
- C. Joint Pattern: As indicated.
- D. Tolerances: Do not exceed 1/16-inch (1.6-mm) unit-to-unit offset from flush (lippage) or 1/8 inch in 24 inches (3 mm in 600 mm) and 1/4 inch in 10 feet (6 mm in 3 m) from level, or indicated slope, for finished surface of paving.
- E. Expansion and Control Joints:
 - 1. Provide for sealant-filled joints at locations and of widths indicated. Provide compressible foam filler as backing for sealant-filled joints unless otherwise indicated; where unfilled joints are indicated, provide temporary filler until paver installation is

**Okaloosa County TDC – Destin Fort Walton Beach Convention Center
Exterior Accessibility**

complete. Install joint filler before setting pavers. Sealant materials and installation are specified in Section 079200 "Joint Sealants."

3.2 SAND SETTING-BED APPLICATIONS

- A. Compact soil subgrade uniformly to at least 95 percent of ASTM D1557 laboratory density.
- B. Place aggregate base, compact by tamping with plate vibrator, and screed to depth indicated.
- C. Place leveling course and screed to a thickness of 1 to 1-1/2 inches (25 to 38 mm), taking care that moisture content remains constant and density is loose and uniform until pavers are set and compacted.
- D. Treat leveling course with herbicide to inhibit growth of grass and weeds.
- E. Set pavers with a minimum joint width of 1/16 inch (1.5 mm) and a maximum of 1/8 inch (3 mm), being careful not to disturb leveling base. Use string lines to keep straight lines. Fill gaps between units that exceed 3/8 inch (10 mm) with pieces cut to fit from full-size unit pavers.
- F. Vibrate pavers into leveling course with a low-amplitude plate vibrator capable of a 3500- to 5000-lbf (16- to 22-kN) compaction force at 80 to 90 Hz. Use vibrator with neoprene mat on face of plate or other means as needed to prevent cracking and chipping of pavers. Perform at least three passes across paving with vibrator.
- G. Spread dry sand and fill joints immediately after vibrating pavers into leveling course. Vibrate pavers and add sand until joints are completely filled, then remove excess sand. Leave a slight surplus of sand on the surface for joint filling.

3.3 MORTAR SETTING-BED APPLICATIONS

- A. Saturate concrete subbase with clean water several hours before placing setting bed. Remove surface water about one hour before placing setting bed.
- B. Apply mortar-bed bond coat over surface of concrete subbase about 15 minutes before placing mortar bed. Do not exceed 1/16-inch (1.6-mm) thickness for bond coat. Limit area of bond coat to avoid its drying out before placing setting bed.
- C. Apply mortar bed over bond coat; spread and screed mortar bed to uniform thickness at subgrade elevations required for accurate setting of pavers to finished grades indicated.
- D. Mix and place only that amount of mortar bed that can be covered with pavers before initial set. Before placing pavers, cut back, bevel edge, and remove and discard setting-bed material that has reached initial set.
- E. Wet pavers before laying if the initial rate of absorption exceeds 30 g/30 sq. in. (30 g/194 sq. cm) per minute when tested according to ASTM C67. Allow units to absorb water so they are damp but not wet at time of laying.

**Okaloosa County TDC – Destin Fort Walton Beach Convention Center
Exterior Accessibility**

- F. Place pavers before initial set of cement occurs. Immediately before placing pavers on mortar bed, apply uniform 1/16-inch- (1.5-mm-) thick bond coat to mortar bed or to back of each paver with a flat trowel.
- G. Tamp or beat pavers with a wooden block or rubber mallet to obtain full contact with setting bed and to bring finished surfaces within indicated tolerances. Set each paver in a single operation before initial set of mortar; do not return to areas already set or disturb pavers for purposes of realigning finished surfaces or adjusting joints.

END OF SECTION 321400

**Okaloosa County TDC – Destin Fort Walton Beach Convention Center
Exterior Accessibility**

Page Left Blank



DAG ARCHITECTS
DAG Architects, AAC000745
1223 Airport Road Destin, Florida 32541
850 837.8152 www.dagarchitects.com

CONSTRUCTION DOCUMENT

DESTIN FORT WALTON BEACH CONVENTION CENTER

EXTERIOR ACCESSIBILITY
TASK ORDER No. 6b - C18-2638-TDD
1250 MIRACLE STRIP PKWY SE
FORT WALTON BEACH, FL 32548

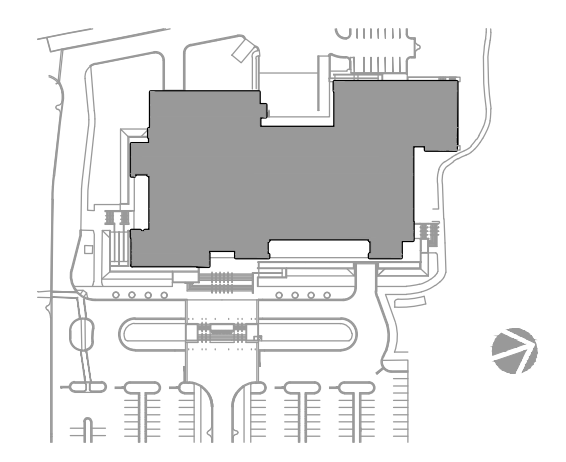

No.	Description	Date

Work Reference Plan

Project number: 17057b
Date: 06-12-2020
PIC: JDB
PM: DJA

G100

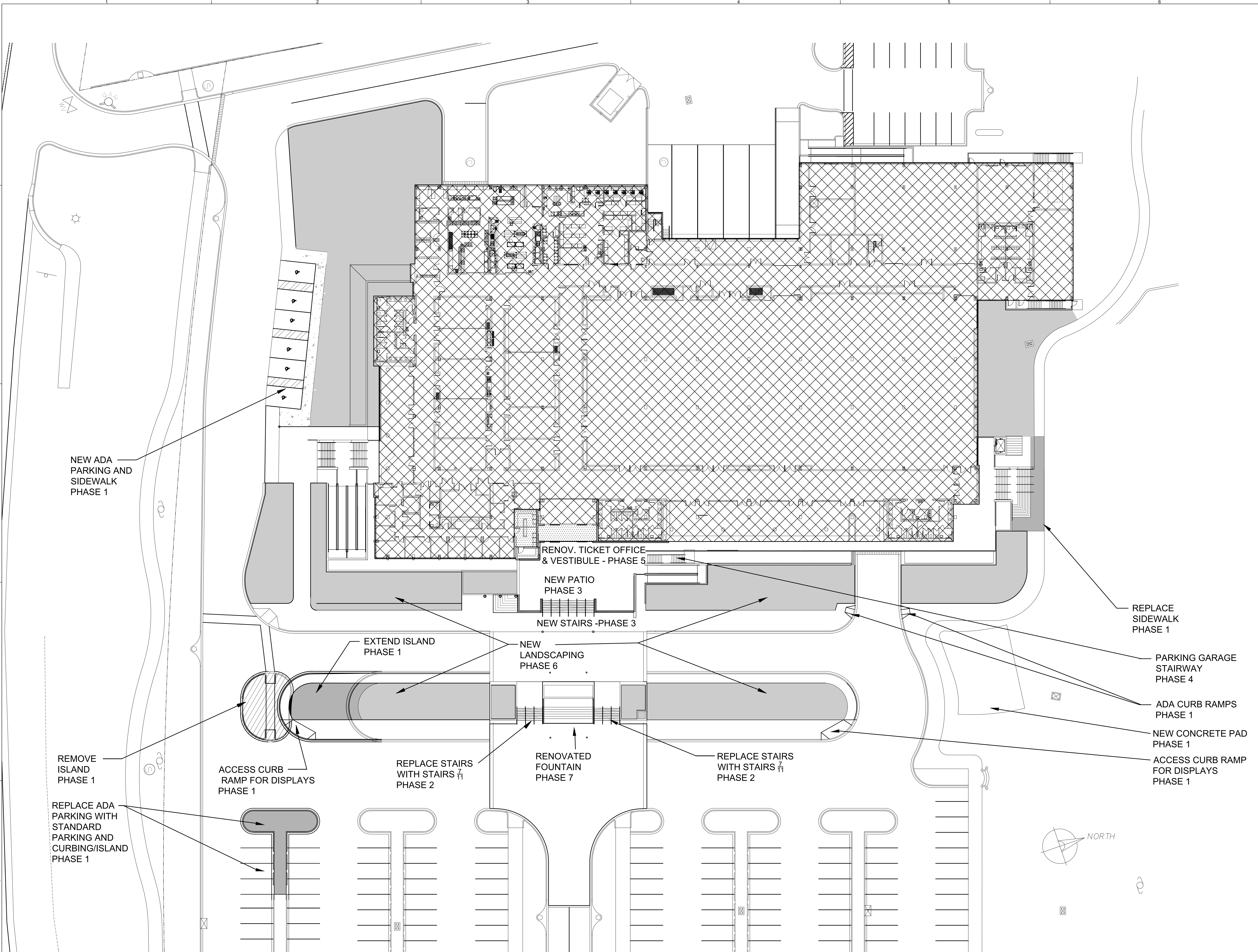

A1 EMERALD COAST CONVENTION CENTER - WORK REFERENCE PLAN

SCALE: 1"=20'-0"

GENERAL NOTES:

- 1. THE EXACT LOCATION AND ELEVATION OF EXISTING STRUCTURES, UTILITIES, AND PIPING SHALL BE PHYSICALLY VERIFIED IN THE FIELD BY THE CONTRACTOR BEFORE CONSTRUCTION BEGINS...
2. THE CONTRACTOR SHALL CHECK PLANS FOR CONFLICTS AND DISCREPANCIES PRIOR TO CONSTRUCTION...
3. THE CONTRACTOR SHALL EXERCISE EXTREME CAUTION IN AREAS OF BURIED UTILITIES AND SHALL PROVIDE AT LEAST 48 HOURS NOTICE TO THE VARIOUS UTILITY COMPANIES...
4. THE CONTRACTOR IS RESPONSIBLE FOR REPAIRING ANY DAMAGE TO EXISTING FACILITIES ABOVE OR BELOW GROUND THAT MAY OCCUR AS A RESULT OF WORK CALLED FOR IN THESE CONTRACT DOCUMENTS...
5. IT SHALL BE THE RESPONSIBILITY OF THE CONTRACTOR TO LEARN, KNOW, AND COMPLY WITH THE REGULATIONS, ORDINANCES, PERMIT AND INSPECTION REQUIREMENTS OF THE VARIOUS GOVERNMENTAL AGENCIES HAVING JURISDICTION OVER THE PROJECT...
6. ALL SPECIFICATIONS AND DOCUMENTS REFERRED TO SHALL BE OF LATEST ISSUE AND SHALL BE CONSIDERED A PART OF THESE DOCUMENTS AS THOUGH INCLUDED...
7. THE CONTRACTOR SHALL COORDINATE WITH THE PROJECT SURVEYOR AND BE RESPONSIBLE FOR THE SETTING OF CONSTRUCTION STAKES TO MARK THE LOCATION, ALIGNMENT, ELEVATION, AND GRADE OF THE WORK...
8. THE CONTRACTOR SHALL OBTAIN AND HAVE ON-SITE ALL PERMITS PRIOR TO CONSTRUCTION...
9. PRIOR TO COMMENCING CONSTRUCTION OR DEMOLITION/LAND CLEARING ACTIVITIES, CONTRACTOR SHALL INSTALL ANY REQUIRED SILT FENCING OR BALED HAY BARRIERS...
10. DEWATERING: SHOULD LOWERING OF GROUNDWATER BE NECESSARY FOR THE INSTALLATION OF CONCRETE STRUCTURES, WATER MAIN ETC., OR TO PREVENT LATERAL MOVEMENT OF MATERIAL UNDER CONCRETE ALREADY PLACED...
11. ALL CONSTRUCTION SHALL BE IN ACCORDANCE WITH FDOT STANDARD SPECIFICATIONS FOR ROAD AND BRIDGE CONSTRUCTION...
12. CONTRACTOR SHALL OBTAIN, IF AVAILABLE, AND REVIEW ALL AVAILABLE GEOTECHNICAL REPORTS PRODUCED FOR THE SITE PRIOR TO COMMENCEMENT OF CONSTRUCTION...
13. CONTRACTOR IS RESPONSIBLE FOR PROVIDING SIGNED AND SEALED RECORD DRAWINGS SHOWING ALL IMPROVEMENTS CONSTRUCTED UNDER THIS CONTRACT...
14. CONTRACTOR IS RESPONSIBLE FOR CONTINUATION OF SERVICE TO OCCUPIED BUILDINGS DURING CONSTRUCTION AND REPAIR OR REPLACEMENT OF ANY EXISTING UTILITIES IMPACTED BY CONSTRUCTION...
15. IF WELLS ARE ENCOUNTERED ON-SITE, THEY SHALL BE ABANDONED BY A FLORIDA CERTIFIED WELL DRILLER USING ABANDONMENT PROCEDURES AND PERMITTING PROCESS OF THE LOCAL WATER MANAGEMENT DISTRICT...
16. IF APPLICABLE, ANY WELLS PROPOSED ON-SITE, I.E. IRRIGATION, GEOTHERMAL, ETC. SHALL BE PERMITTED APPROPRIATELY THROUGH THE LOCAL WATER MANAGEMENT DISTRICT...
17. CONTRACTOR SHALL CALL BEFORE DIGGING TO SUNSHINE STATE ONE CALL OF FLORIDA AT 800-432-4770.

HANDICAP ACCESSIBILITY:

- 1. HANDICAP RAMPS AND CROSSWALKS PER THE LATEST FLORIDA ACCESSIBILITY CODE, A.D.A. AND FDOT STANDARD INDEX #304 ARE REQUIRED AT ALL PEDESTRIAN CROSSING LOCATIONS.

ARCHITECTURAL COORDINATION:

- 1. WHEN APPLICABLE, ARCHITECTURAL PLANS SHALL SUPERSEDE THESE PLANS WITH RESPECT TO ALL BUILDING DIMENSIONS AND BUILDING HARDSCAPE INTERFACE, IN CASE OF CONFLICT AND PRIOR TO CONSTRUCTION, CONTRACTOR IS RESPONSIBLE FOR CONTACTING BOTH THE ENGINEER AND ARCHITECT IMMEDIATELY.

STRUCTURAL COORDINATION:

- 1. WHEN APPLICABLE, CONTRACTOR SHALL REFER TO THE CONSTRUCTION DETAILS AND SPECIFICATIONS OF THE APPLICABLE STRUCTURAL PLANS FOR ALL SITE RETAINING WALLS AND OTHER STRUCTURAL COMPONENTS.

SIGNAGE:

- 1. PROJECT SIGNS SHALL MEET ALL APPLICABLE REQUIREMENTS BASED ON LOCAL SIGN ORDINANCE.
2. CONTRACTOR IS RESPONSIBLE FOR SIGN PERMITTING.

DEMOLITION:

- 1. ALL EXISTING CONCRETE, ASPHALT, TREES, STUMPS, AND OTHER DELETERIOUS MATERIAL AS INDICATED ON THE PLANS SHALL BE REMOVED FROM THE SITE AND DISPOSED OF IN ACCORDANCE WITH THE FLORIDA LAWS.
2. WHERE PAVEMENT IS TO BE REMOVED AND REPLACED, AS INDICATED ON THE PLANS OR DIRECTED IN THE FIELD, ALL EXISTING PARKINGS AND TRAFFIC LOOPS SHALL ALSO BE REPLACED, THERE WILL BE NO DIRECT PAYMENT FOR THIS WORK, COST SHALL BE INCLUDED IN RELATED ITEMS OF WORK.
3. ALL EXISTING PAVEMENT AND DRIVEWAY PAVEMENT TO BE REMOVED SHALL BE SAW CUT.
4. REPAIR ALL EXISTING DRIVEWAYS CROSSED BY WATER MAIN TO MATCH EXISTING CONSTRUCTION.
5. CONTRACTOR SHALL TRIM, TACK AND MATCH EXISTING PAVEMENT AT LOCATIONS WHERE NEW PAVEMENT ABUTS.
6. ANY DISTURBED MAIL BOXES OR SIGNS MUST BE REINSTALLED TO EXISTING OR ACCEPTABLE CONDITION AT THE CONTRACTOR'S EXPENSE.

SEDIMENTATION AND EROSION CONTROL NOTES:

- 1. CONTRACTOR SHALL STAGE AND TIME CONSTRUCTION TO MINIMIZE THE SIZE OF EXPOSED SOIL AREAS AND THE TIME BETWEEN EXPOSING THE SOIL AREA AND FINISHING THE SOIL AREA.
2. AS SOON AS GRADING IS COMPLETE IN AN AREA, THE CONTRACTOR WILL STABILIZE THE SOIL. FOR LONG, NARROW AREAS, THE CONTRACTOR SHALL STABILIZE CONTINUOUSLY DURING GRADING OPERATIONS. ROUGH GRADED AREAS SHOULD BE STABILIZED WITH TEMPORARY EROSION CONTROL. IF FINAL GRADING AND STABILIZATION WILL NOT BE PERFORMED WITHIN FIVE (5) DAYS, FAILURE TO STABILIZE EXPOSED SOIL AREAS IN A TIMELY MANNER AFTER GRADING MAY BE CONSIDERED A VIOLATION OF CHAPTERS 17-3, 17-2, AND/OR 17-25, FLORIDA ADMINISTRATIVE CODE, BY THE FLORIDA DEPARTMENT OF ENVIRONMENTAL PROTECTION (F.D.E.P.) AND SUBJECT TO CORRECTIVE ACTION, PURSUANT TO SECTION 402.12, 403.161 FLORIDA STATUTES.
3. IT SHALL BE THE RESPONSIBILITY OF THE CONTRACTOR PERFORMING A TASK TO PROVIDE EROSION CONTROL UNLESS ANOTHER PARTY HAS BEEN PREVIOUSLY SPECIFIED AS RESPONSIBLE FOR THE EROSION CONTROL ASSOCIATED WITH THAT TASK. IN THE EVENT ANOTHER PARTY IS RESPONSIBLE FOR EROSION CONTROL, THE CONTRACTOR SHALL STILL BE RESPONSIBLE FOR COORDINATION WITH THE PARTY RESPONSIBLE. IN THE EVENT THAT DAMAGE TO THE CONSTRUCTED ITEM RESULTS ARE DUE TO LACK OF EROSION CONTROL, THE CONTRACTOR SHALL REPAIR OR REPLACE THE ITEM AT NO CHARGE TO THE OWNER.
4. TEMPORARY EROSION CONTROL SHALL CONSIST OF TEMPORARY GRASS, TEMPORARY MULCH, TEMPORARY SOD, ARTIFICIAL COVERINGS, BALED HAY OR STRAW, SILT FENCES, AND TURBIDITY BARRIERS AS SHOWN ON THE CONSTRUCTION DRAWINGS AND IN ACCORDANCE WITH APPROPRIATE TECHNICAL SPECIFICATIONS. IF TECHNICAL SPECIFICATIONS ARE NOT PROVIDED, THEN TEMPORARY EROSION CONTROL SHALL BE IN ACCORDANCE WITH SECTION 104 OF THE FLORIDA DEPARTMENT OF TRANSPORTATION (F.D.O.T.) STANDARD SPECIFICATIONS.
5. PERMANENT CONTROL SHALL CONSIST OF SEED, SEED AND MULCH, HYDRO-SEEDING, SOD, AND/OR ARTIFICIAL COVERINGS AS SHOWN ON THE CONSTRUCTION DRAWINGS AND IN ACCORDANCE WITH THE TECHNICAL SPECIFICATION SECTIONS 12 AND 13. IF TECHNICAL SPECIFICATIONS ARE NOT PROVIDED, THEN PERMANENT EROSION CONTROL SHALL BE IN ACCORDANCE WITH SECTIONS 570 AND 575 OF THE F.D.O.T. STANDARD SPECIFICATIONS. SEED PR GRASS TYPE SHALL MATCH EXISTING OR BE AS SPECIFIED BY OWNER UNLESS NOTED OTHERWISE.
6. GRASS BY SEEDING SHALL BE IN ACCORDANCE WITH SECTIONS 104, 570, 981, 982, AND 983 OF F.D.O.T. STANDARD SPECIFICATIONS. THIS SHALL BE USED ONLY IN AREAS SUBJECT TO LIGHT EROSION SUCH AS FLAT AREAS.
7. GRASS BY HYDRO-SEEDING SHALL BE IN ACCORDANCE WITH SECTIONS 104, 570, 981, 982, 983 OF F.D.O.T. STANDARD SPECIFICATIONS. HYDRO-SEEDING MAY BE USED FOR FLAT AREAS AND SIDE SLOPES WHICH DO NOT EXCEED 4:1. DRAINAGE DITCHES OR LARGE SWALES MUST HAVE ADDITIONAL PROTECTION BESIDES HYDRO-SEEDING.
8. GRASS AND MULCH SHALL BE IN ACCORDANCE WITH SECTIONS 104, 570, 981, 982, AND 983 OF F.D.O.T. STANDARD SPECIFICATIONS. GRASS AND MULCH MAY BE USED IN ALL AREAS EXCEPT LARGE SWALES OR DITCHES, MULCH SHALL BE ANCHORED IN ACCORDANCE WITH SECTION 570.
9. SOLID SOD SHALL BE IN ACCORDANCE WITH SECTIONS 104, 575, 981, 982, 983 OF F.D.O.T. STANDARD SPECIFICATIONS. SOD MAY BE USED IN ALL AREAS FOR SIDE SLOPES GREATER THAN OR EQUAL TO 2:1. SOD SHALL BE STAGGERED SO AS TO AVOID A CONTINUOUS SEAM. IN AREAS WITH SLOPES 4:1 OR STEEPER, EACH PIECE OF SOD SHALL BE PEGGED WITH SOD PEGS. IN DIFFICULT SOIL CONDITIONS WITH STEEP SLOPES, IT MAY BE NECESSARY TO COVER SOD WITH ARTIFICIAL COVERINGS SUCH AS JUTE MESH UNTIL SOD BECOMES ESTABLISHED.
10. TEMPORARY EROSION CONTROL BY ARTIFICIAL COVERINGS SHALL CONSIST OF STRAW BLANKETS, COCONUT FIBER BLANKETS, POLYESTER BLANKETS, JUTE MESH, AND DRAINAGE FABRICS. MATERIALS SHALL BE INSTALLED IN ACCORDANCE WITH MANUFACTURER'S RECOMMENDATIONS. SEEDING SHALL BE INCLUDED IF MATERIAL REQUIRES VEGETATION TO FUNCTION PROPERLY.
11. THE CONTRACTOR IS TO PROVIDE EROSION CONTROL/SEDIMENTATION BARRIER (HAY BALES, SILT FENCE, TURBIDITY BARRIER, OR AS SPECIFIED IN THE CONSTRUCTION DRAWINGS) TO PREVENT SILTATION OF ADJACENT PROPERTY, STREETS, STORM SEWERS, WATERWAYS, AND WETLAND OR JURISDICTIONAL AREAS. IF, IN THE OPINION OF THE ENGINEER, AND/OR REGULATORY AUTHORITIES, EXCESSIVE QUANTITIES OF MATERIAL ARE TRANSPORTED OFF-SITE BY EROSION OR STORMWATER RUNOFF, THE CONTRACTOR SHALL IMPROVE CONDITIONS TO THE SATISFACTION OF THE ENGINEER AND/OR AUTHORITIES. IN NO CASE SHALL CONSTRUCTION COMMENCE PRIOR TO INSTALLATION OF EROSION CONTROL/SEDIMENTATION BARRIER.
12. CONTRACTOR SHALL PLACE STRAW, MULCH, OR OTHER SUITABLE MATERIAL ON GROUND IN ADDITION TO COARSE AGGREGATE IN AREAS WHERE CONSTRUCTION RELATED TRAFFIC IS TO ENTER AND EXIT SITE.
13. IF WIND EROSION BECOMES SIGNIFICANT DURING CONSTRUCTION, THE CONTRACTOR SHALL STABILIZE THE AREA USING SPRINKLING IRRIGATION OR OTHER ACCEPTABLE METHODS.
14. ALL DISTURBED AREAS NOT PAVED, SODDED OR OTHERWISE LANDSCAPED SHALL BE SEED, FERTILIZED AND MULCHED PER FDOT SPECIFICATIONS, SECTION 570. SEEDING RATE AND MIX SHALL COMPLY WITH THE SEEDING RATE TABLE OFF DOT STANDARD INDEX 105.
15. CONTRACTOR SHALL SOD ALL SLOPES 4:1 AND STEEPER IMMEDIATELY AFTER CONSTRUCTION UNLESS OTHERWISE DIRECTED BY THE ENGINEER.
16. CONTRACTOR SHALL REFER TO DEMOLITION AND EROSION CONTROL MAP FOR LIMITS OF CLEARING, TREE REMOVAL, AND EROSION CONTROL.
17. ALL EXCAVATED SOILS SHALL BE STOCKPILED IN LOCATION(S) INDICATED ON PLANS IF SHOWN. APPROPRIATE SEDIMENTATION AND EROSION CONTROLS SHALL BE INSTALLED AROUND THE STOCKPILE.

MAINTENANCE:

- 18. THE CONTRACTOR SHALL PROVIDE ROUTINE MAINTENANCE OF PERMANENT AND TEMPORARY EROSION CONTROL FEATURES IN ACCORDANCE WITH TECHNICAL SPECIFICATIONS SECTION 10, 12, AND 13 UNTIL THE PROJECT IS COMPLETED AND ACCEPTED. IF TECHNICAL SPECIFICATIONS ARE NOT PROVIDED, THEN MAINTENANCE SHALL BE IN ACCORDANCE WITH SECTION 104 OF THE FLORIDA DEPARTMENT OF TRANSPORTATION (F.D.O.T.) STANDARD SPECIFICATIONS.
19. SILT FENCES AND TURBIDITY BARRIERS SHALL BE CHECKED DAILY FOR EFFECTIVENESS, BREACHES, AND ROUTINE MAINTENANCE.
20. ALL DISTURBED AREAS TO BE PERMANENTLY GRASSED AND RELETION AREAS TO BE SODDED.

PAVING, GRADING & EARTHWORK NOTES:

- 1. IN EXCAVATING STREETS AND DRIVEWAYS THAT HAVE BEEN SURFACED WITH SAND-CLAY, CLAY GRAVEL, OR OTHER BASE COURSE, SUCH BASE MATERIALS SHALL BE EITHER STOCKPILED AND KEPT SEPARATE FROM THE EARTH EXCAVATED OR THE CONTRACTOR SHALL, AT HIS EXPENSE, PROVIDE NEW BASE OF LIKE KIND AND EQUAL QUALITY.
2. CONTRACTOR MUST SALVAGE EXISTING TOP SOIL WITHIN PROJECT SIRE OR REPLACE AT HIS OWN EXPENSE.
3. ANY DEFICIENT IN THE QUANTITY OF THE MATERIAL FOR BACKFILLING THE TRENCHED, OR FOR FILLING DEPRESSIONS CAUSED BY SETTLEMENT, SHALL BE SUPPLIED BY THE CONTRACTOR AT NO COST TO THE OWNER. THIS ALSO APPLIES TO BASE COURSE UNDER PAVED STREETS.
4. CONTRACTOR SHALL CLEAR AND GRUB ONLY THOSE PORTIONS OF THE SITE NECESSARY FOR CONSTRUCTION. CLEAR AND GRUB SHALL CONSIST OF THE REMOVAL OF ALL DELETERIOUS MATERIAL INCLUDING TREES, ROOTS, TOPSOIL, ETC.
5. ALL AREAS DISTURBED BY CONSTRUCTION ACTIVITIES SHALL BE SEED, MULCHED, SODDED, STABILIZED, OR PLANTED WITH OTHER APPROVED LANDSCAPE MATERIAL, WITHIN FIVE (5) DAYS AFTER CONSTRUCTION.
6. ORGANIC, UNSUITABLE SOILS BENEATH THE PAVED AREAS SHALL BE REMOVED AND REPLACED WITH CLEAN SAND MATERIAL OF WHICH NOT MORE THAN 15% BY DRY WEIGHT IS FINER THAN THE NUMBER 200 MESH SIEVE. FILL MATERIAL SHALL BE FREE OF ORGANICS, RUBBLE, CLAY, OR OTHER DELETERIOUS MATTER.
7. IF NECESSARY, THE PAVEMENT SUBGRADE SHOULD BE STABILIZED TO AN LBR OF 40. MATERIAL FOR STABILIZATION SHALL BE AS CALLED OUT ON PLANS, OR OTHER MATERIAL APPROVED BY THE ENGINEER AND THE GEOTECHNICAL ENGINEER. COMPACTION OF THE SUBGRADE SHALL BE BY A HEAVY VIBRATORY ROLLER (MINIMUM STATIC WEIGHT OF FIVE TONS) WITH A MINIMUM OF 10 PASSES WITH A 20% OVERLAP BETWEEN PASSES. THE VIBRATORY ROLLER SHOULD ALSO BE EQUIPPED WITH A VARIABLE FREQUENCY CONTROL TO OPERATE AT THE RESONANT FREQUENCY OF THE SOILS.
8. ALL WASTE MATERIAL SHALL BE DISPOSED OF OFFSITE IN ACCORDANCE WITH APPLICABLE REGULATIONS.
9. PROPOSED SPOT ELEVATIONS REPRESENT FLOW LINE OF CURB & GUTTER OR FINISHED PAVEMENT OR GROUND SURFACE GRADE UNLESS OTHERWISE NOTED ON DRAWINGS.
10. CONTRACTOR TO PROVIDE 1/2" TO 1" BITUMINOUS EXPANSION JOINT MATERIAL WITH SEALER AT ABUTMENT OF CONCRETE AND OTHER MATERIALS (BUILDINGS, OTHER POURED CONCRETE, ETC.) EXCEPT ASPHALT.
11. CONTRACTOR SHALL TRIM, TACK AND MATCH EXISTING PAVEMENT AT LOCATIONS WHERE NEW PAVEMENT ABUTS.
12. TESTING REQUIREMENTS SHALL BE IN ACCORDANCE WITH THE TESTING SCHEDULE CONTAINED WITHIN THESE PLANS. SELECTION AND CONTRACTING WITH THE TESTING FIRMS SHALL BE THE RESPONSIBILITY OF THE CONTRACTOR. IT SHALL BE THE RESPONSIBILITY OF THE CONTRACTOR TO COORDINATE AND SCHEDULE ALL TESTS.
13. ACCEPTANCE TESTING FOR NEW PAVEMENT, IF APPLICABLE, SHALL CONSIST OF ONE PASS OF A STANDARD 15-FOOT ROLLING STRAIGHT GEDGE OPERATED WHILE THE PAVEMENT IS STILL HOT. ALL DEFICIENCIES IN EXCESS OF 1/8" INCH SHALL BE CORRECTED IN ACCORDANCE WITH F.D.O.T. STANDARD SPECIFICATION 330.
14. AT THE OPTION OF THE OWNER, THE CONTRACTOR SHALL FLOOD ALL NEW PAVEMENT SURFACES WITH WATER AND INSPECT FOR PONDING. ALL PONDING AREAS SHALL BE CORRECTED IN ACCORDANCE WITH F.D.O.T. STANDARD SPECIFICATION 330.

TRAFFIC, SIGNAGE & STRIPING NOTES:

- 1. IT SHALL BE THE CONTRACTOR'S SOLE RESPONSIBILITY TO MAINTAIN ADEQUATE TRAFFIC CONTROL AND TO PROVIDE DETOURS AROUND CONSTRUCTION ACTIVITIES, UNLESS APPROVED BY THE OWNER. IN WRITING, NO STREET SHALL REMAIN CLOSED TO TRAFFIC OVERNIGHT. IN ADDITION, THE CONTRACTOR SHALL COOPERATE WITH LOCAL RESIDENTS IN GAINING ACCESS TO THEIR HOMES AND BUSINESSES DURING WORKING HOURS AND SHALL ASSIST AT ALL TIMES WHEN VEHICLES EXPERIENCE TROUBLE DUE TO CONSTRUCTION ACTIVITIES.
2. THE CONTRACTOR SHALL INSTALL ALL TRAFFIC CONTROL DEVICES REQUIRED FOR THE PROJECT IN ACCORDANCE WITH THE LATEST EDITION OF THE U.S. DEPARTMENT OF TRANSPORTATION FEDERAL HIGHWAY ADMINISTRATION MANUAL ON UNIFORM TRAFFIC CONTROL.
3. ALL PAVEMENT MARKINGS SHALL BE MADE WITH REFLECTORIZED TRAFFIC PAINT IN ACCORDANCE WITH F.D.O.T. STANDARD SPECIFICATIONS 710 AND STANDARD INDEX NO. 117346. SHEETS 1-7. TRAFFIC STRIPING AND MARKINGS SHALL BE THERMOPLASTIC UNLESS OTHERWISE DIRECTED BY THE ENGINEER.

SITE DRAINAGE NOTES:

- 1. ALL OFF-SITE AND ON-SITE WORK INCLUDED CONSISTS OF BUT NOT LIMITED TO THE FOLLOWING:
1.1. EXCAVATION, BEDDING, FILTER MATERIAL AND BACKFILL FOR ALL STORM SEWER, SUBSURFACE DRAINS AND DRAINAGE STRUCTURES. COMPLETE INSTALLATION OF ALL STORM SEWERS, SUBSURFACE DRAINS, CATCH BASINS, JUNCTION BOXES, MANHOLES, ETC., INCLUDING ALL RELATED FITTINGS, JOINTS, COVERS, GRATES, FRAMES, RINGS, ETC.
2. ANY WORK WITHIN STREET OR HIGHWAY RIGHT-OF-WAY SHALL BE DONE IN ACCORDANCE WITH THE REQUIREMENTS OF THE GOVERNMENTAL AGENCIES HAVING JURISDICTION AND SHALL NOT BEGIN UNTIL ALL OF THESE GOVERNING AUTHORITIES HAVE BEEN NOTIFIED. POLYVINYL CHLORIDE (PVC), FOR PIPE UP TO AND INCLUDING TEN INCHES (10") IN DIAMETER, SHALL CONFORM TO ASTM D3034 SDR 35 WITH ELASTOMETRIC GASKET JOINTS CONFORMING TO ASTM D3212.
3. REINFORCED CONCRETE PIPE
3.1. FOR PIPE TWELVE INCHES (12") IN DIAMETER AND UP, SHALL CONFORM TO ASTM C-76, CLASS IV OR AASHTO M-170 WITH BELL AND SPIGOT OR TONGUE AND GROOVE COMPRESSION JOINT CONFORMING TO ASTM C-443.
4. MANHOLES, CATCH BASINS, ETC. SHALL BE SIZE AND TYPE INDICATED ON THE DRAWINGS AND SHALL BE CONSTRUCTED OF THE FOLLOWING:
4.1. REINFORCED PRECAST CONCRETE MANHOLE SECTIONS INCLUDING CONCENTRIC OR ECCENTRIC CONES AND GRADE RINGS SHALL BE 4000 PSI CONCRETE AND CONFORM TO ASTM C-478 OR AASHTO M-199. SECTIONS SHALL BE COMPLETE WITH 3/4" ROUND CAST IN PLACE WROUGHT IRON STEPS.
5. BRICK SHALL BE SOUND, HARD BURNED THROUGHOUT AND OF UNIFORM SIZE AND QUALITY AND SHALL BE IN ACCORDANCE WITH ASTM C-32. GRADE MS OR MM.
6. CONCRETE MASONRY SHALL BE SOLID PRECAST SEGMENTAL CONCRETE MASONRY UNITS CONFORMING TO ASTM C-139.
7. IRON CASTINGS SHALL CONFORM TO ASTM A-48, CLASS 30.
7.1. BEARING SURFACES BETWEEN CAST IRON FRAMES, COVERS AND GRATES SHALL MACHINED, FITTED TOGETHER AND MATCH MARKED TO PREVENT ROCKING.
7.2. SYSTEM IDENTIFYING LETTER 2" HIGH SHALL BE STAMPED OR CAST INTO ALL COVERS SO THAT THEY MAY BE PLAINLY VISIBLE. CASTINGS SHALL BE MANUFACTURED BY EAST JORDAN IRON WORKS, INC., NEEHAH FOUNDRY COMPANY, VULCAN FOUNDRY COMPANY OR EQUAL.
8. MANHOLE STEPS FOR BRICK OR CONCRETE MASONRY STRUCTURES SHALL BE CAST IRON ASPHALT COATED, NEEHAH FOUNDRY COMPANY "R-1980-E" OR EQUAL.
9. CONCRETE AND MASONRY MATERIALS FOR CONSTRUCTION OF STORM DRAINAGE STRUCTURES SHALL CONSIST OF THE FOLLOWING:
9.1. PORTLAND CEMENT SHALL BE STANDARD BRAND OF PORTLAND CEMENT CONFORMING TO ASTM C-150, TYPE I OR II.
9.2. FINE AND COARSE AGGREGATES FOR CONCRETE SHALL BE PER ASTM C-33. AGGREGATES SHALL BE WELL GRADED FROM FINE TO COARSE WITHIN LIMITS SPECIFIED IN ASTM C-33. MAXIMUM SIZE OF COARSE AGGREGATE SHALL BE 3/4". AGGREGATE FOR CEMENT SHALL BE CLEAN, SHARP SAND CONFORMING TO ASTM C-144. GRADE SAND FROM COARSE TO FINE WITH 100% PASSING NO. 8 SIEVE, AND NOT OVER TO 30% PASSING NO. 50 SIEVE.
9.3. HYDRATED LIME SHALL COMPLY WITH ASTM 0-207, TYPE S.
9.4. WATER SHALL BE CLEAN AND FREE FROM DELETERIOUS MATERIALS.
9.5. ALL MATERIAL USED FOR CONCRETE AND THE DESIGN OF ALL CONCRETE MIXES SHALL CONFORM WITH THE RECOMMENDATIONS OF THE AMERICAN CONCRETE INSTITUTE (ACI 211.1-81). ALL CONCRETE, UNLESS NOTED OTHERWISE, SHALL DEVELOP A 28-DAY COMPRESSIVE STRENGTH OF 3000 PSI.
9.6. JOINT SEALANT SHALL BE HOT LAID BITUMINOUS SEALER.
9.7. RIPRAP SHALL BE SOUND, TOUGH DURABLE ROCK OR BROKEN CONCRETE AS APPROVED BY THE GEOTECHNICAL ENGINEER. RIPRAP SHALL BE AT LEAST EIGHT INCH (8") IN ONE DIMENSION AND SHALL HAVE A VOLUME OF NOT LESS THAN 1 1/2 CUBIC FOOT, SMALLER PIECES PERMITTED FOR FILLING VOIDS.
9.8. REINFORCING STEEL FOR CONCRETE SHALL BE INTERMEDIATE GRADE NEW BILLET STEEL CONFORMING TO ASTM A-615, GRADE 40.
9.9. WELDED WIRE MESH SHALL CONFORM TO ASTM DESIGNATION A185 FOR SMOOTH WIRE AND ASTM A497 FOR DEFORMED WIRE.
9.10. FORMS FOR FOUNDATIONS AND OTHER CONCRETE WORK SHALL BE WOOD. FORMS SHALL BE OF SUFFICIENT STRENGTH TO PREVENT DEFORMATION UNDER LOAD AND TIGHT ENOUGH TO PREVENT LEAKAGE. FOUNDATIONS MAY BE POURD AGAINST EARTH WHERE CONDITIONS PERMIT.
9.11. ALL REINFORCEMENT SHALL BE FABRICATED AND PLACED IN ACCORDANCE WITH ACI 318-77. WELDED WIRE MESH SHALL BE LAPPED 6-INCHES AT ALL EDGES.
9.12. THE MIXING, PLACING, CURING AND FINISHING OF CONCRETE SHALL COMPLY WITH ACI 304 AND ACI 318. ALL EXPOSED SURFACES SHALL BE GIVEN A HARD STEEL TROWELED FINISH WITH NO TROWEL MARKS REMAINING. NO CEMENT SHALL BE DUSTED ON THE SURFACE. ALL CONCRETE SHALL BE CURED BY COASTING WITH A CLEAR CURING NO CEMENT CONFORMING TO ASTM C-304, OR BY KEEPING IT WET FOR AT LEAST SIX DAYS AFTER POURING. AFTER THE FORMS ARE STEPPED, ALL EXPOSED CONCRETE SURFACES SHALL BE POINTED AS NEEDED AND RUBBED TO A UNIFORM FINISH.
9.13. CONCRETE, UNLESS OTHERWISE NOTED, SHALL HAVE COMPRESSIVE STRENGTH AFTER 28 DAYS OF 3000 PSI MINIMUM. MIX SHALL BE SO PROPORTIONED TO PROVIDE A MINIMUM OF 517 POUNDS OF CEMENT PER CUBIC YARD.
9.14. CONCRETE FILL BELOW GRADE FOR PIPE CRADLES ETC. MAY BE 2500 PSI AT 28 DAYS.
9.15. CONCRETE, WHERE EXPOSED TO THE WEATHER SHALL BE AIR ENTRAINED. AIR ENTRAINMENT SHALL BE ACCOMPLISHED BY THE USE OF ADDITIVES CONFORMING TO ASTM C-260. AIR CONTENT SHALL BE 6%±5% + 1%±5%. ADDITIVE SHALL BE USED STRICTLY IN ACCORDANCE WITH MANUFACTURERS PRINTED DIRECTIONS.
9.16. READY-MIX CONCRETE SHALL CONFORM TO THE REQUIREMENTS OF ASTM C-94.
9.17. CEMENT MORTAR SHALL BE AS SPECIFIED HEREINAFTER. USE METHODS OF MIXING MORTAR MATERIALS CAN BE CONTROLLED AND ACCURATELY MAINTAINED DURING WORK PROGRESS. MORTAR SHALL NOT BE MIXED IN GREATER QUANTITIES THAN SATISFACTORY WORKABILITY. RETEMPERING OF MORTAR IS NOT PERMITTED.
9.18. MORTAR FOR LAYING BRICK OR CONCRETE MASONRY UNITS SHALL CONFORM TO ASTM C-270, TYPE M, AVERAGE COMPRESSIVE STRENGTH 2500 AT 28 DAYS. MORTAR MIX SHALL BE PROPORTIONED BY VOLUME. MORTAR FOR PRICING SHALL CONSIST OF ONE PART PORTLAND CEMENT AND TWO PARTS SAND.
9.19. MORTAR FOR GROUTING OF RIPRAP SHALL CONSIST OF ONE PART PORTLAND CEMENT AND THREE PARTS SAND.

GENERAL TESTING NOTES:

- 1. TESTING SHALL BE IN ACCORDANCE WITH THE TESTING SCHEDULE CONTAINED WITHIN THESE PLANS. SELECTION AND CONTRACTING WITH THE TESTING FIRMS SHALL BE THE RESPONSIBILITY OF THE CONTRACTOR. IT SHALL BE THE RESPONSIBILITY OF THE CONTRACTOR TO COORDINATE AND SCHEDULE ALL TESTS.
2. COPIES OF THE TEST FOR ASPHALT, BASE, SUBGRADE, FILL, AND BACKFILL UNDER ROADWAYS AND STRUCTURES, AND UTILITY TRENCHES SHALL BE PROVIDED DIRECTLY TO THE ENGINEER FOR APPROVAL. IT SHALL BE THE RESPONSIBILITY OF THE CONTRACTOR TO COORDINATE TESTING AND INSURE THAT ALL APPLICABLE TESTS HAVE BEEN PERFORMED. FAILURE TO OBTAIN TEST RESULTS AT ANY POINT OF CONSTRUCTION WILL REQUIRE THE REMOVAL OF THE IMPROVEMENT AND REPLACEMENT BY CONTRACTOR, AT NO ADDITIONAL COST TO THE OWNER. IT SHOULD BE NOTED THAT THE APPLICABLE LOCAL GOVERNMENT MAY REQUIRE COMPACTION TESTING IN ACCORDANCE WITH THE TESTING SCHEDULE FOR UTILITY TRENCH FILL AND BACKFILL OR ACCORDING TO THE LOCAL GOVERNMENTAL STANDARDS, WHICHEVER IS MORE STRINGENT.

TESTING SCHEDULE:

Table with columns: ITEM, TEST, TEST IDENTIFICATION, TEST REQUIREMENT, TEST FREQUENCY. Rows include UTILITY TRENCH FILL & BACKFILL, FILL & BACKFILL UNDER ROADWAYS AND STRUCTURES, SUBGRADE, BASE (SAND-ASPHALT), ASPHALT, CONCRETE (MISC. SITE WORK), and various density and strength tests.

NOTE: CONCRETE FOR SITE WORK INCLUDES BUT IS NOT LIMITED TO CURB, CURB & GUTTER, SIDEWALKS, ETC., EXCEPT CONCRETE PAVEMENT.

REFERENCE SOURCES:

Table with columns: AASHTO, ANSI, ASTM, FDOT, FDEP and their corresponding organizations like AMERICAN ASSOCIATION OF HIGHWAY TRANSPORTATION OFFICIALS, AMERICAN NATIONAL STANDARDS INSTITUTE, AMERICAN SOCIETY OF TESTING MATERIALS, FLORIDA DEPARTMENT OF TRANSPORTATION, FLORIDA DEPARTMENT OF ENVIRONMENTAL PROTECTION.



DAG ARCHITECTS, AAO000745
1223 Airport Road Destin, Florida 32541
850.837.8152 www.dagarchitects.com

CONSTRUCTION DOCUMENT

DESTIN FORT WALTON BEACH CONVENTION CENTER

EXTERIOR ACCESSIBILITY
TASK ORDER No. 68 - C18-2638-TDD
1250 MIRACLE STRIP PKWY SE
FORT WALTON BEACH, FL 32548

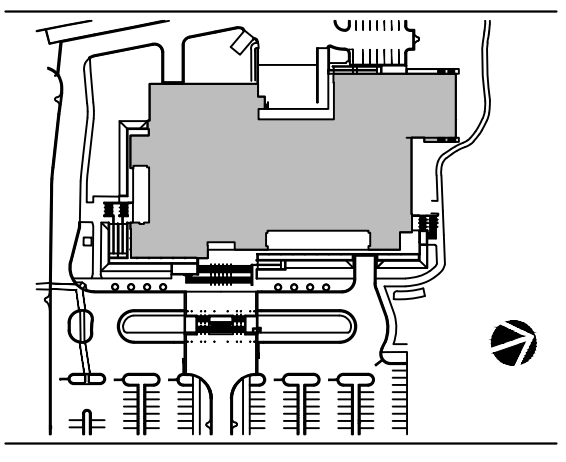

FOR BID ONLY

Table with columns: No., Description, Date. Empty rows for recording test results.

GENERAL NOTES

O'CONNELL & ASSOCIATES CONSULTING ENGINEERS, L.L.C.
1994 Co. Hwy. 283 S., Bldg. #3 Santa Rosa Beach Fl. 32459
(850) 403-6555 www.oconnellengineers.com

Table with columns: Project number, Date, PIC, PM and corresponding values: 170576, 06-12-2020, NOC, JEN.

C100

ALL REPORTS, PLANS, SPECIFICATIONS, COMPUTER FILES, FIELD DATA, NOTES AND OTHER DOCUMENTS AND INSTRUMENTS PREPARED BY THE CONSULTANT SHALL REMAIN THE PROPERTY OF THE CONSULTANT. THE CONSULTANT SHALL RETAIN ALL COMMON LAW, STATUTORY AND OTHER RIGHTS IN ANY SUCH MATERIALS. THE CONSULTANT'S LIABILITY SHALL BE LIMITED TO THE PROFESSIONAL SERVICES PROVIDED BY THE CONSULTANT. THE CONSULTANT SHALL NOT BE HELD RESPONSIBLE FOR THE ACTIONS OF ANY OTHER PROFESSIONAL ENGINEER OR ARCHITECT. AN INDIVIDUAL EMPLOYEE OR AGENT MAY NOT BE HELD INDIVIDUALLY LIABLE FOR NEGLIGENCE.



- EXISTING CONDITIONS NOTES:**
1. THE EXISTING CONDITIONS SHOWN HEREIN REFLECT AS-BUILT CONDITIONS AS SHOWN BY THE SURVEY ENTITLED "EMERALD COAST CONVENTION CENTER" BY GUSTON, COTHERN AND TUCKER, INC., DATED MARCH 31, 2019.
 2. NO UNDERGROUND IMPROVEMENTS WERE LOCATED AND THE LOCATIONS OF UNDERGROUND INFRASTRUCTURE SHOWN HEREIN ARE APPROXIMATE.
 3. CONTRACTOR SHALL FIELD VERIFY ALL UNDERGROUND UTILITIES PRIOR TO CONSTRUCTION.

ONSITE SOILS LEGEND:

MAP UNIT SYMBOL	MAP UNIT NAME	HYDROLOGIC SOIL GROUP
(27)	URBAN LAND	A/D
(18)	NEWHAN COROLLA COMPLEX	A



CONSTRUCTION DOCUMENT

DESTIN FORT WALTON BEACH CONVENTION CENTER
EXTERIOR ACCESSIBILITY
TASK ORDER No. 6b - C18-2638-TDD
1250 MIRACLE STRIP PKWY SE
FORT WALTON BEACH, FL 32548

LEGEND

	EXISTING
PROPERTY LINE (SUBJECT PROPERTY)	---
PROPERTY LINE (OFF SITE)	- - - -
EASEMENT LINE	- · - · -
FLOOD LINE	— · — · —
CCCL LINE	— · — · —
MAJOR CONTOUR LINE	10' — · — · —
MINOR CONTOUR LINE	5' — · — · —
WATER LINE	— W —
FORCE MAIN	— FM —
GAS	— G —
OVERHEAD POWER	— OHP —
FIBER OPTIC	— FO —
CHAIN LINK FENCE	— CLF —
WOODEN FENCE	— WF —
HYDROLOGIC SOIL GROUP LINE	— HSL —
STORM PIPE	— SP —
SIGN	— S —
FIRE HYDRANT	— FH —
VALVE	— V —
WATER METER	— WM —
GAS METER	— GM —
POWER POLE	— PP —
SERVICE POLE	— SP —
LIGHT POLE	— LP —
GUY WIRE	— GW —
ELECTRICAL PEDESTAL	— EP —
CABLE PEDESTAL	— CP —
TELEPHONE PEDESTAL	— TP —
AIR CONDITIONING UNIT	— ACU —
STRUCTURE	— ST —
ASPHALT PAVEMENT	— ASP —
CONCRETE PAVEMENT	— CON —
PAVERS	— PAV —

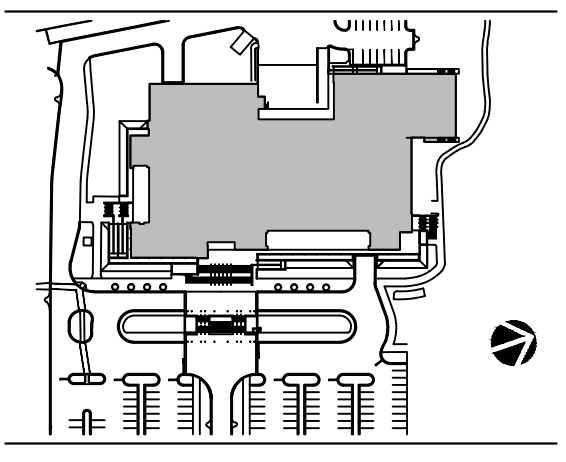

FOR BID ONLY

No.	Description	Date

EXISTING CONDITIONS PLAN

Project number: 17057b
 Date: 06-12-2020
 PIC: NOC
 PM: JEN

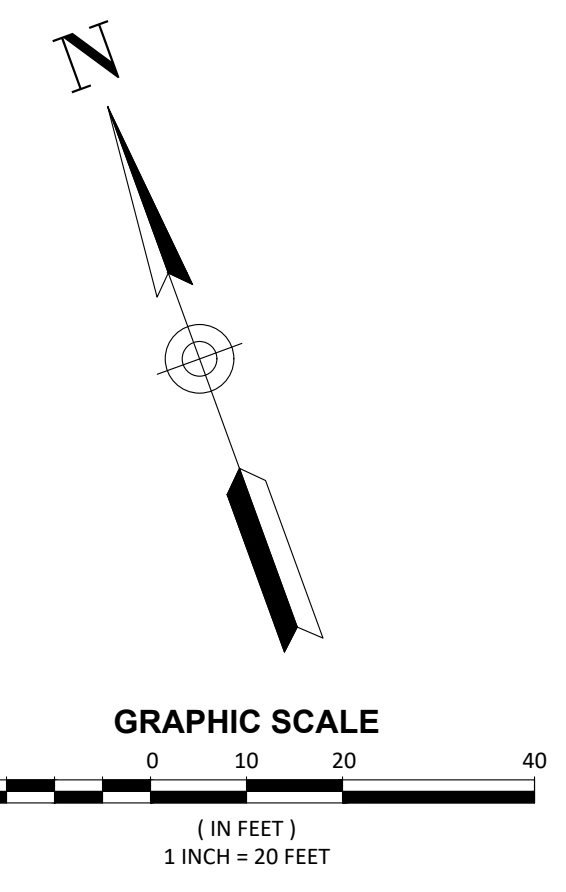

O'CONNELL & ASSOCIATES
 CONSULTING ENGINEERS, L.L.C.
 CERT. OF AUTH. #30549
 1394 Co. Hwy. 283 S. Bldg. #3 Santa Rosa Beach FL 32459
 (850) 433-4555 www.oconnellengineers.com



C201



DAG ARCHITECTS
DAG Architects, AAC000745
1223 Airport Road Destin, Florida 32541
850.837.8152 www.dagarchitects.com

CONSTRUCTION DOCUMENT

DESTIN FORT WALTON BEACH CONVENTION CENTER

EXTERIOR ACCESSIBILITY
TASK ORDER No. 6b - C18-2638-TDD
1250 MIRACLE STRIP PKWY SE
FORT WALTON BEACH, FL 32548

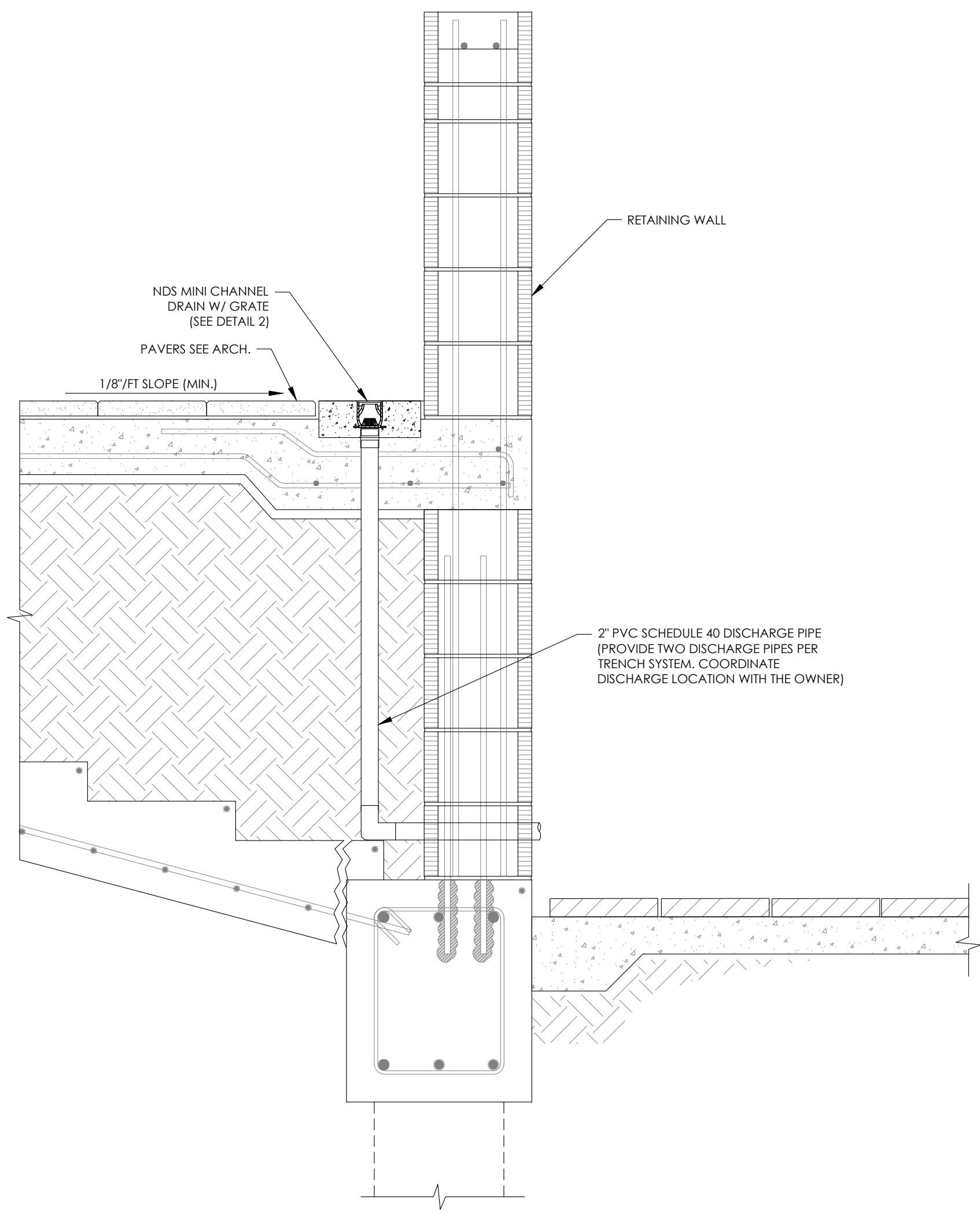

1 NDS MINI CHANNEL RETAINING WALL DETAIL
SCALE: N.T.S.

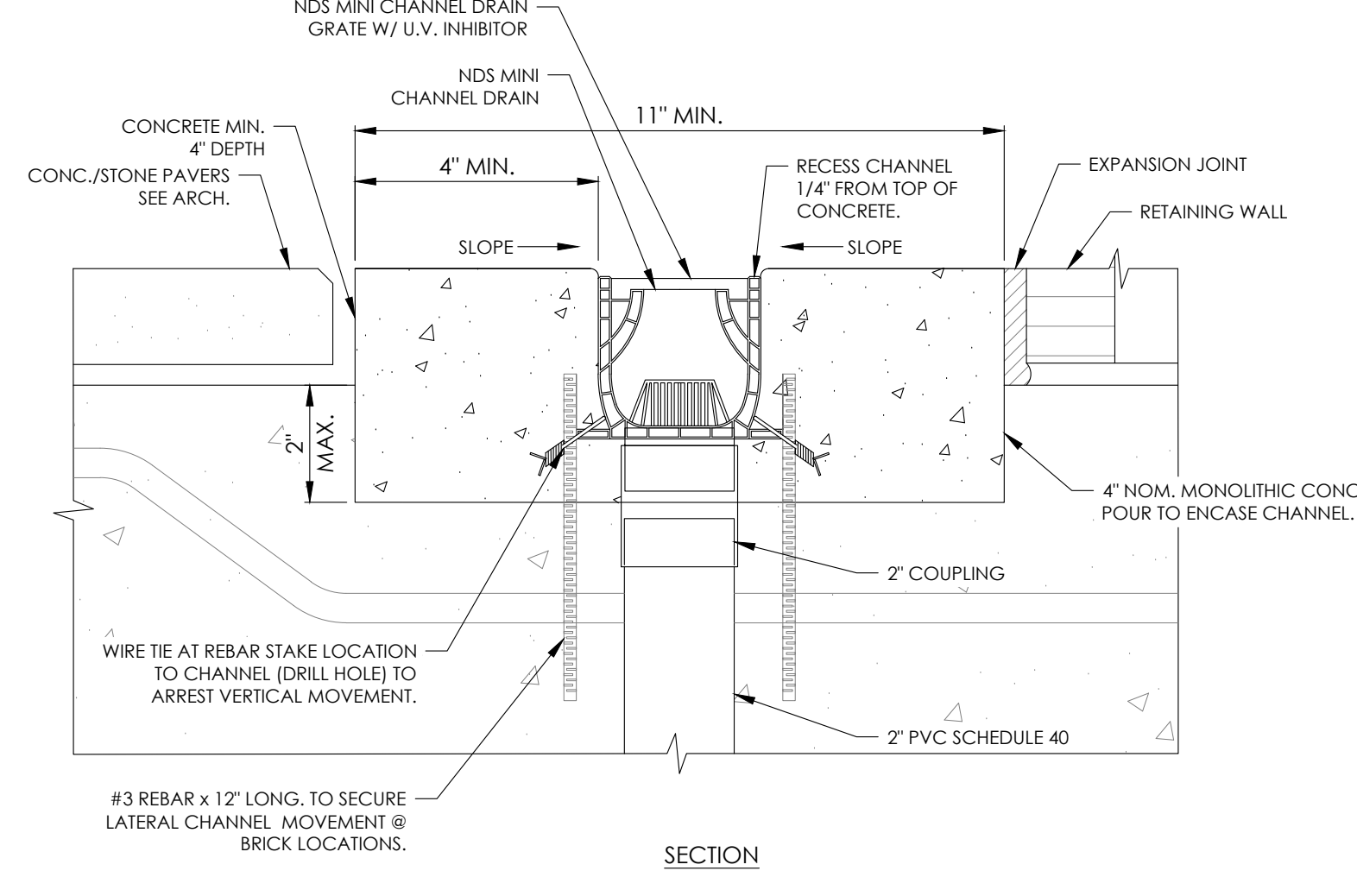

2 NDS MINI CHANNEL TYP. INSTALLATION
SCALE: N.T.S.

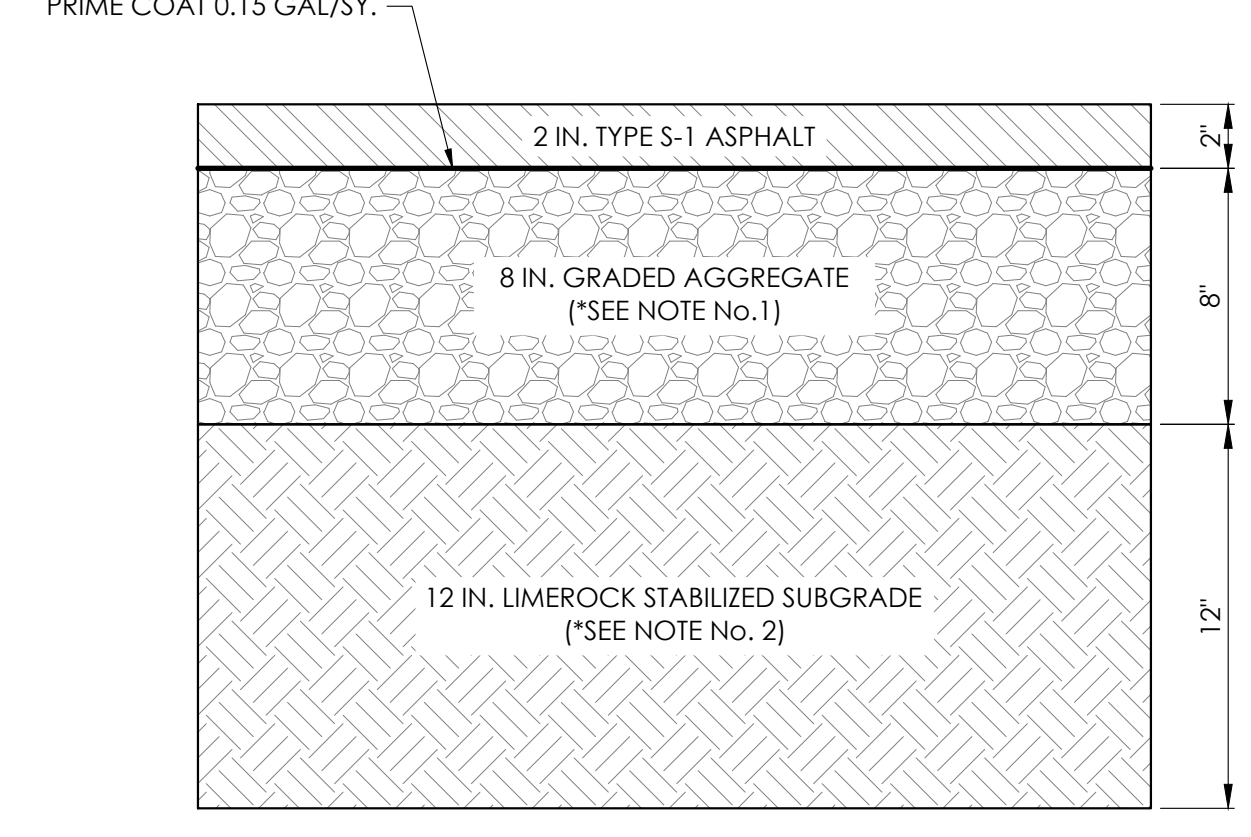

3 PAVEMENT DETAIL
SCALE: N.T.S.

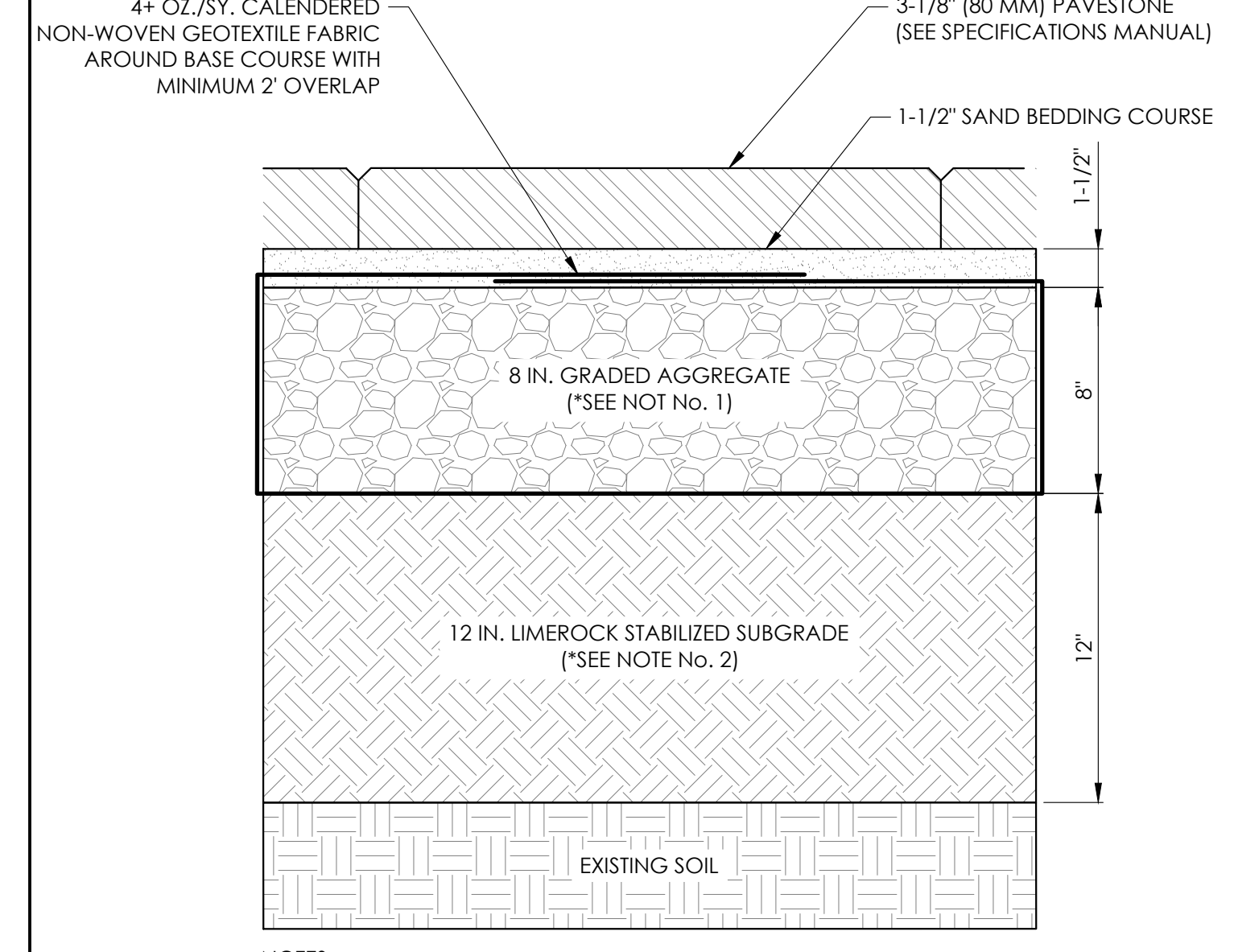

4 CONCRETE PAVERS (FOR VEHICULAR USE AREAS) DETAIL
SCALE: N.T.S.

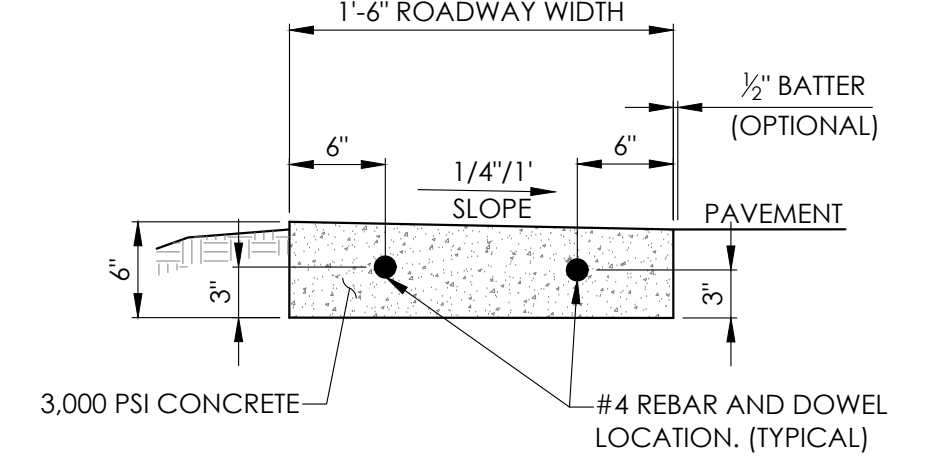

5 18" RIBBON CURB DETAIL
SCALE: N.T.S.

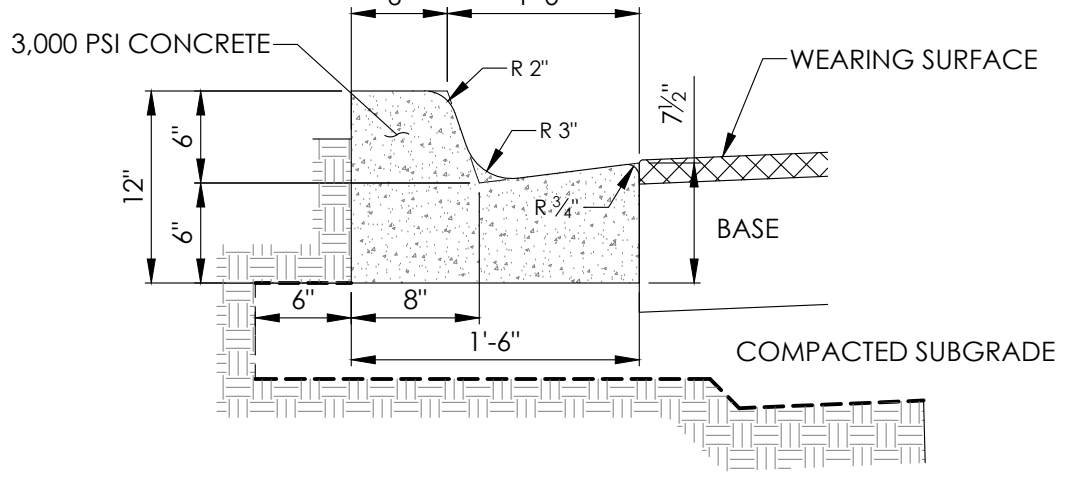

6 CURB AND GUTTER DETAIL
SCALE: N.T.S.

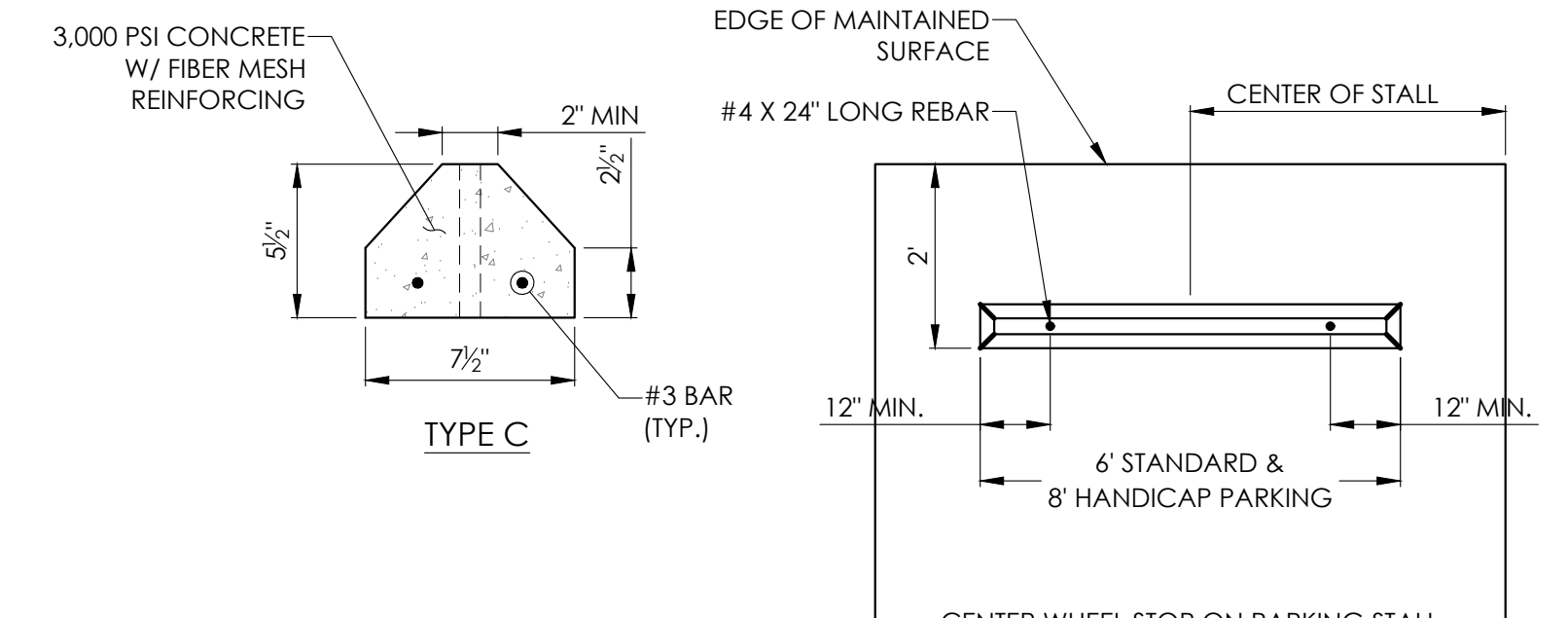

7 REINFORCED CONCRETE WHEEL STOP DETAIL
SCALE: N.T.S.

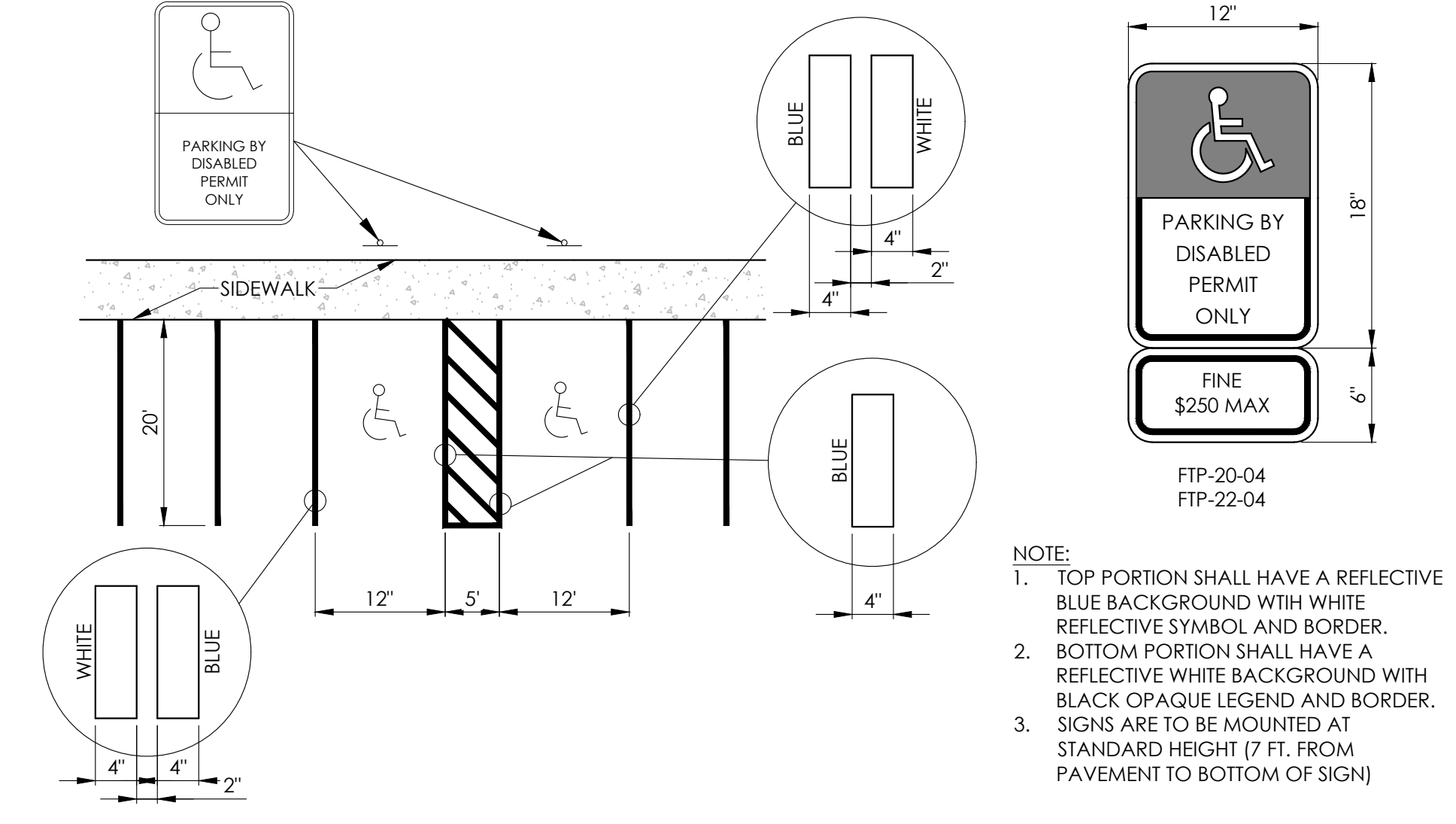

8 HANDICAP PARKING SIGN DETAIL
SCALE: N.T.S.

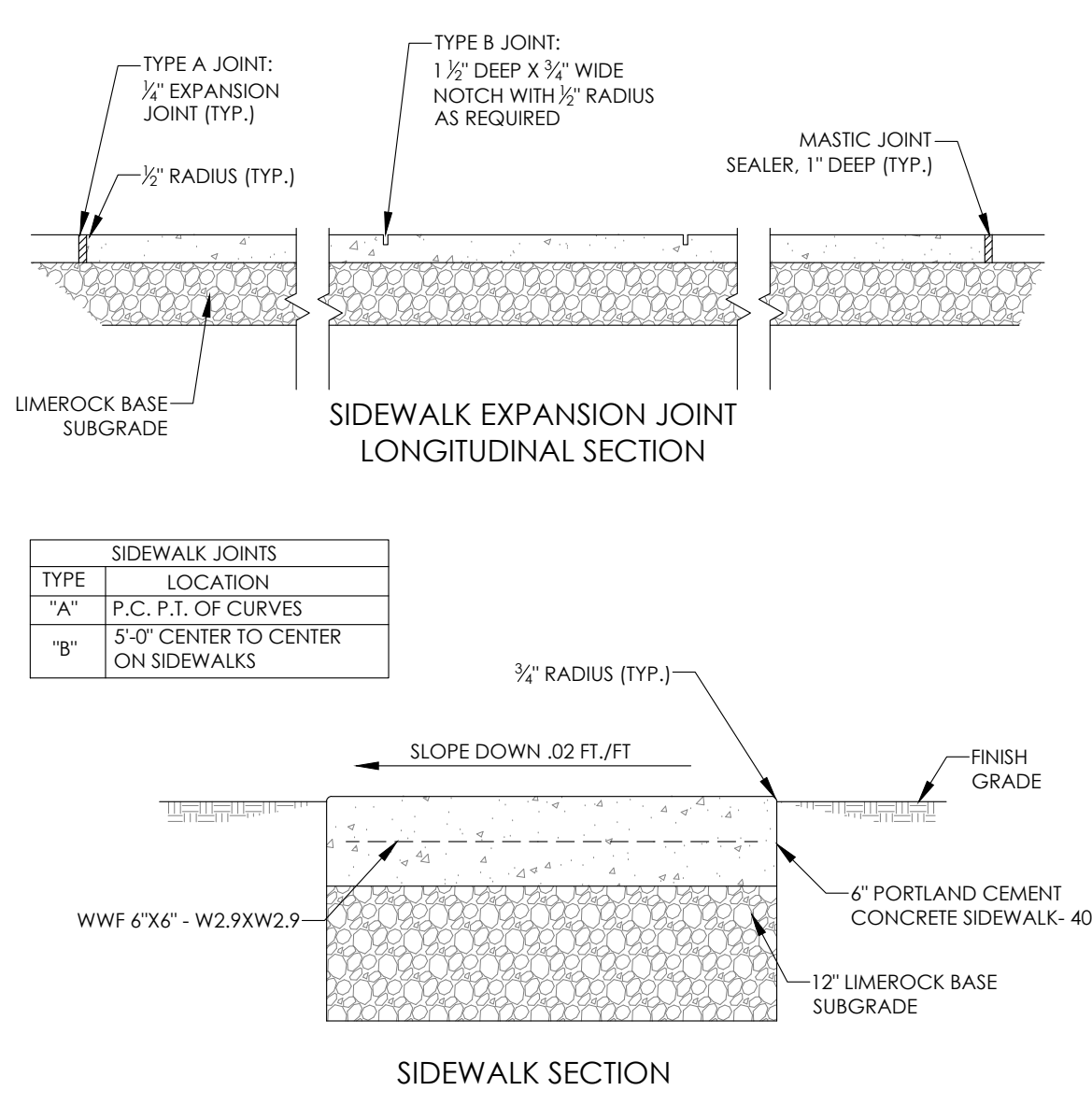

9 CONCRETE SIDEWALK DETAIL
SCALE: N.T.S.

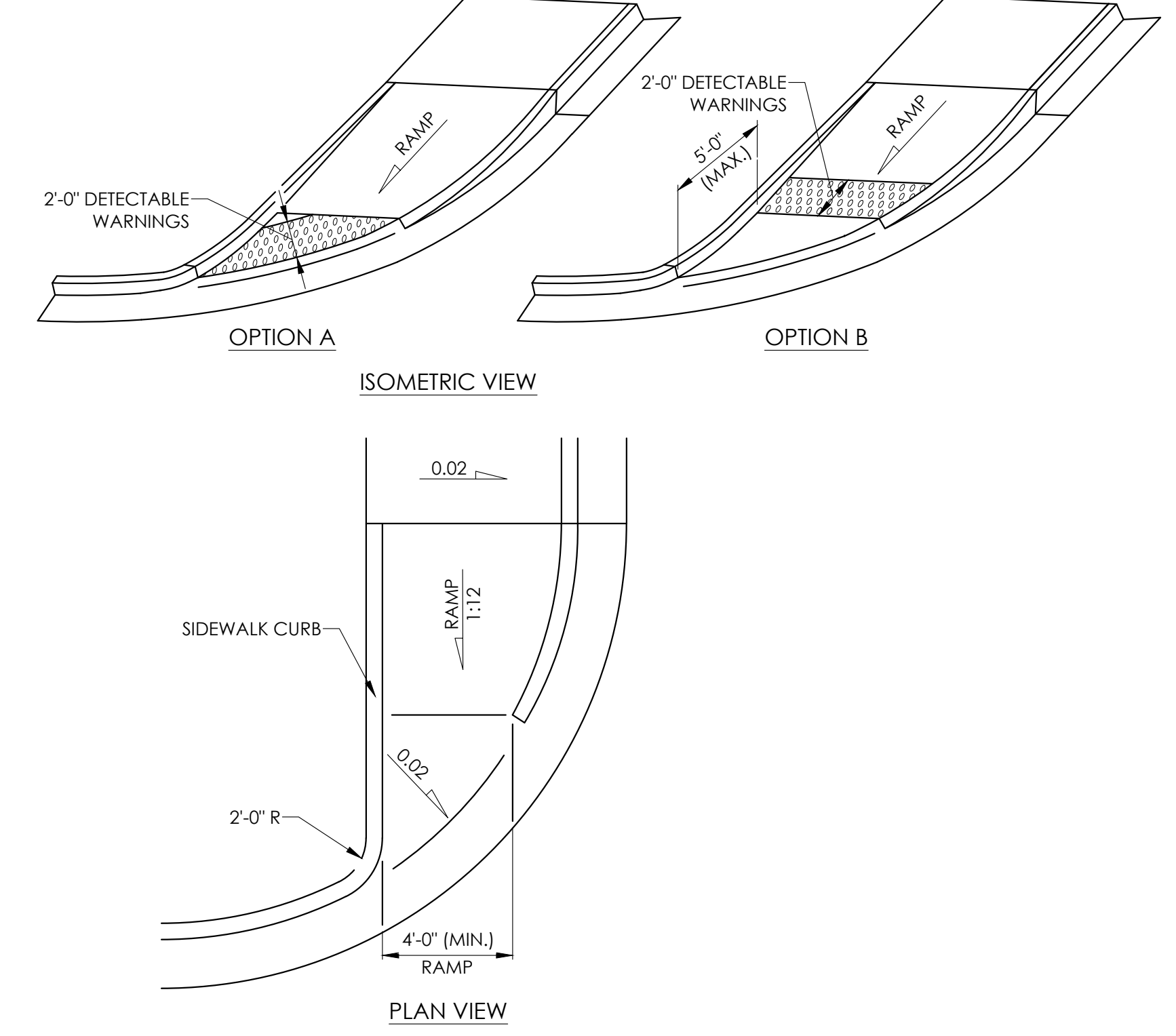

10 CR-G SIDEWALK CURB DETAIL FDOT INDEX 304
SCALE: N.T.S.

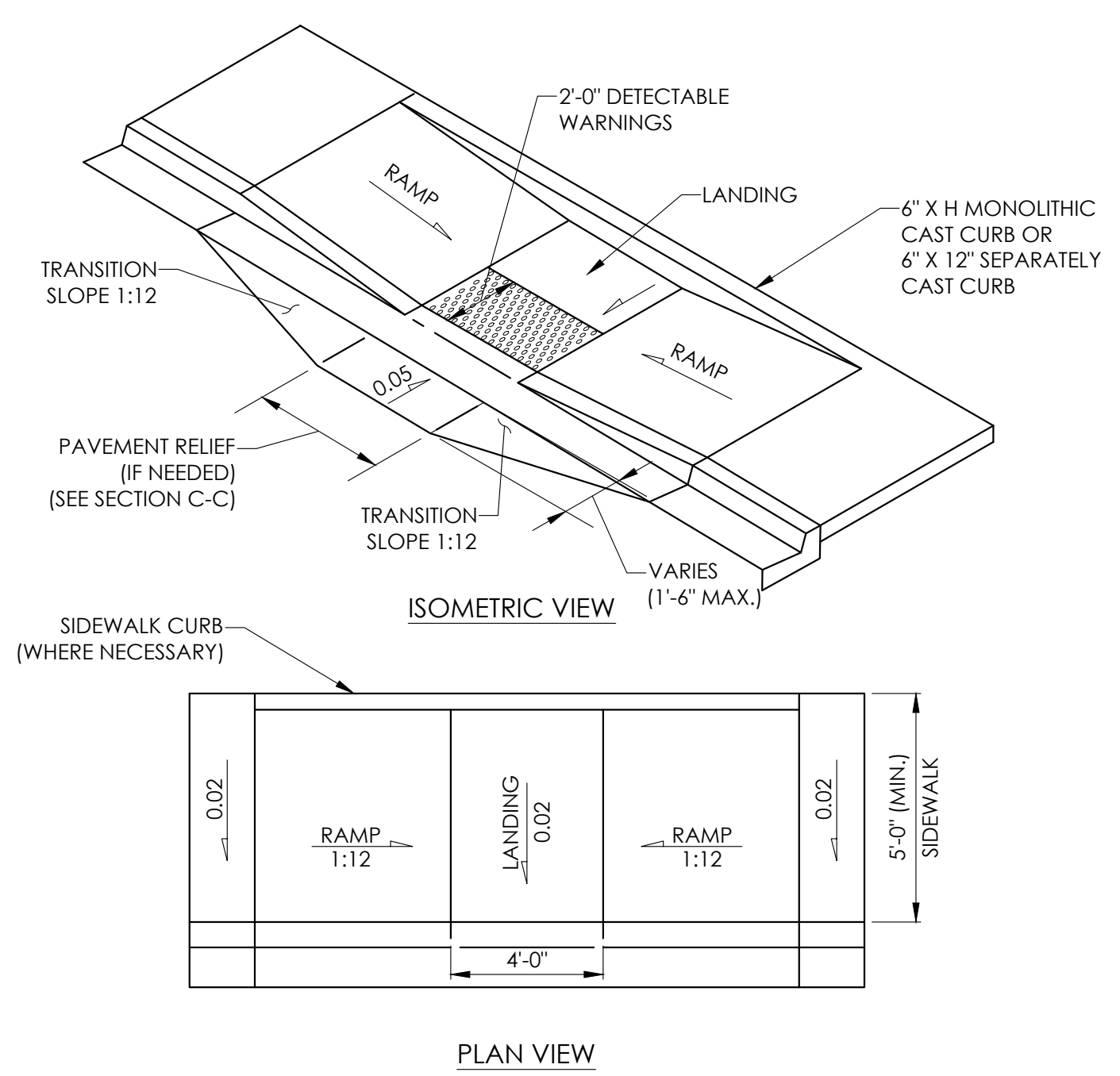

11 CR-C SIDEWALK CURB DETAIL FDOT INDEX 304
SCALE: N.T.S.

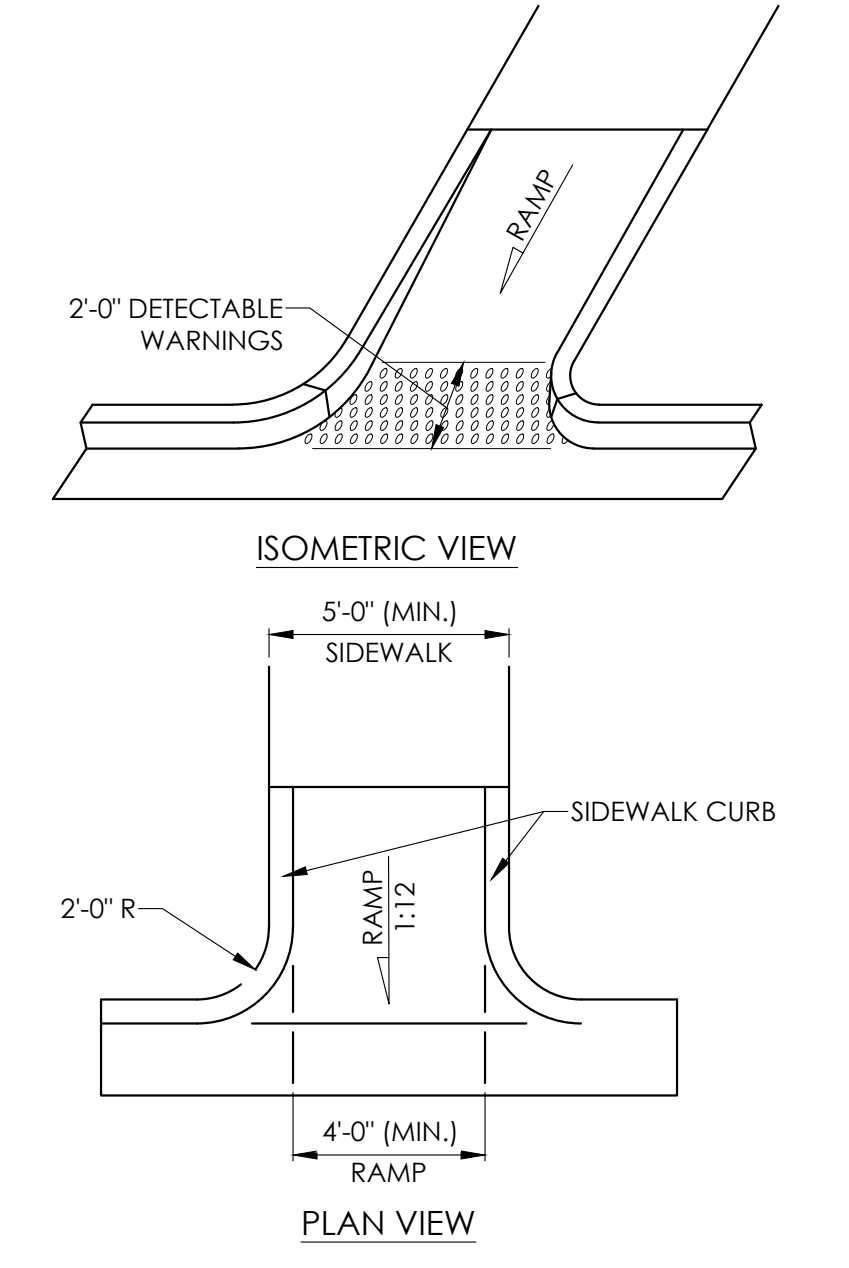

12 CR-E SIDEWALK CURB DETAIL FDOT INDEX 304
SCALE: N.T.S.

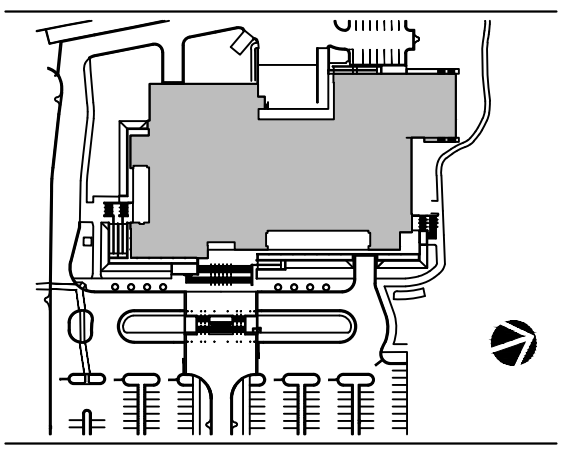

FOR BID ONLY

Table with 3 columns: No., Description, Date. Empty rows for tracking changes.

CONSTRUCTION DETAILS

O'CONNELL & ASSOCIATES CONSULTING ENGINEERS, L.L.C. Project number: 17057b Date: 06-12-2020 PIC: NOC PM: JEN

STRUCTURAL GENERAL NOTES

STRUCTURAL INSPECTION

- 1.1. STRUCTURAL ENGINEER TO BE NOTIFIED IN WRITING ONE WEEK (IF POSSIBLE, THREE DAYS MINIMUM PRIOR TO ALL STRUCTURAL INSPECTION DATES)...

STRUCTURAL MEMBER CALLOUT LEGEND

Table with columns MW#, MPR#, MCA# and descriptions for CONCRETE MASONRY and CIP CONCRETE.

PLAN SYMBOL LEGEND

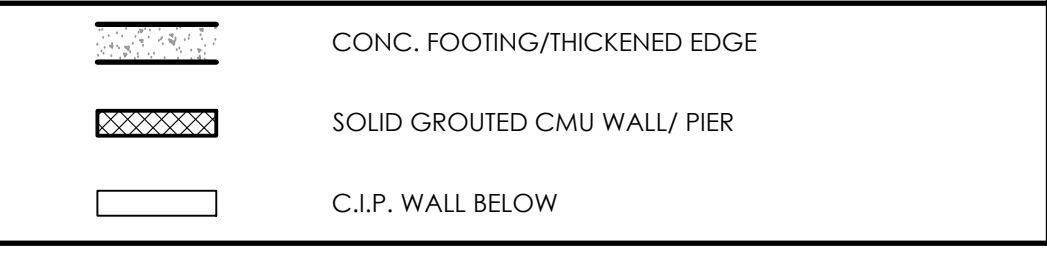

GENERAL

- 1. NO PROVISION OF ANY REFERENCED STANDARD SPECIFICATION, MANUAL OR CODE (WHETHER OR NOT SPECIFICALLY INCORPORATED BY REFERENCE IN THE CONTRACT DOCUMENTS) SHALL BE EFFECTIVE TO CHANGE THE DUTIES AND RESPONSIBILITIES OF OWNER, CONTRACTOR, ENGINEER, SUPPLIER, OR ANY OF THEIR CONSULTANTS, AGENTS, OR EMPLOYEES...

CODE DESIGN

- 1. STRUCTURE IS DESIGNED IN ACCORDANCE WITH THE 2017 FLORIDA BUILDING CODE. 2. GRAVITY LOADS: 2.1. UNIFORM FLOOR LIVE LOADS (REDUCED AS ALLOWED BY THE BUILDING CODE): DECKS AND PORCHES 100 PSF...

FOUNDATION

- 1. FOUNDATION DESIGN IS BASED ON RECOMMENDATIONS IN THE REPORT GEOTECHNICAL SERVICES FOR THE PROPOSED ADDITIONS AT THE EMERALD COAST CONVENTIONS CENTER IN FORT WALTON BEACH, FLORIDA (CONTRACT C18-2638-TDD).

REINFORCEMENT

- 1. REINFORCING STEEL SHALL CONFORM TO ASTM A615, GRADE 60, UNLESS NOTED OTHERWISE. 2. WELDED WIRE FABRIC SHALL CONFORM TO ASTM A185 AND HAVE MINIMUM SIDE AND END LAPS OF 8".

Table: MINIMUM LAP SPICE LENGTH (IN.) for various concrete grades and conditions.

Table: MINIMUM LAP SPICE LENGTH (IN.) - 1500 PSI NORMAL WEIGHT CMU.

Table: RECOMMENDED END HOOKS EMBEDMENT LENGTH (IN.) for different bar sizes.

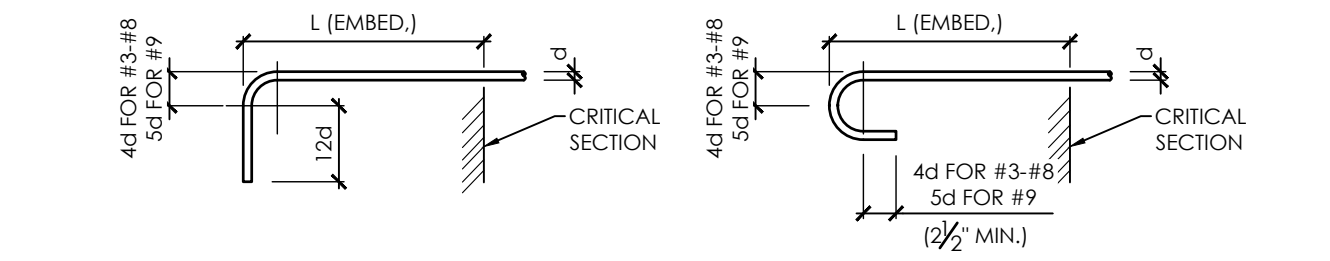

Table: REINFORCEMENT SHALL BE SPECIFIED ONLY AT LOCATIONS SHOWN OR NOTED IN THE STRUCTURAL DOCUMENTS.

ABBREVIATIONS

Table of abbreviations: AB ANCHOR BOLT, AFF ABOVE FINISH FLOOR, ARCH ARCHITECTURAL, BLDG BUILDING, BM BEAM, BOT BOTTOM, BRG BEARING, CANT CANTILEVERED, CIP CAST IN PLACE, CONJR CONTROL JOINT, CLR CLEAR, CMU CONCRETE MASONRY UNIT, COL COLUMN, CONC CONCRETE, CONN CONNECTION, CONT CONTINUOUS, COORD COORDINATE, DIM DIMENSION, DL DEAD LOAD, DN DOWN, DWGS DRAWINGS, EA EACH, ECS ELEVATED CONCRETE SLAB, EE EACH END, EJ EXPANSION JOINT, EL ELEVATION, ELEV ELEVATOR, EOS EDGE OF SLAB, EQ EQUAL, EQUIP EQUIPMENT, EXST EXISTING, EW EACH WAY, EXP EXPANSION, EXT EXTERIOR, FFE FINISH FLOOR ELEVATION, FLR FLOOR, FRF FIRE RETARDANT TREATED, FTG FOOTING, GA GAUGE, GALV GALVANIZED, GC GENERAL CONTRACTOR, GLU GLUED LAMINATED LUMBER, GT GIRDER TRUSS, HK HOOK, HORIZ HORIZONTAL, HS HIGH STRENGTH, HT HEIGHT, INT INTERIOR, JBE JOIST BEARING ELEVATION, JT JOINT, LBS POUNDS, LGS LIGHT GAGE STEEL, LL LEVEL LOAD, LH LONG LEG VERTICAL, LLV LONG LEG VERTICAL, LSH LONG SIDE HORIZONTAL, LSV LONG SIDE VERTICAL, LVL LAMINATED VENEER LUMBER, LW LIGHT WEIGHT, MAS MASONRY, MAX MAXIMUM, MECH MECH, MFR MANUFACTURER, MISC MISCELLANEOUS, MIN MINIMUM, ML MASONRY LINTEL, MS MAT SLAB, NO NUMBER, NIC NOT IN CONTRACT, NTS NOT TO SCALE, NW NORMAL WEIGHT, OC ON CENTER, OPP OPPOSITE, OH OPPOSITE HAND, OWSJ OPEN WEB STEEL JOIST, P PLATE, PFD POWDER DRIVEN FASTENER, PL PLATE, PLS POUNDS PER LINEAR FOOT, PSF POUNDS PER SQUARE FOOT, PSI POUNDS PER SQUARE INCH, PT FOR WOOD, PRESURE TREATED FOR CONCR. SLAB, POST-TENSIONED, RC REINFORCED CONCRETE, REF REFERENCE, RENF REINFORCING, REQD REQUIRED, SIM SIMILAR, SOG SLAB-ON-GRADE, SP SOUTHERN PINE, SPA SPACE, STD STANDARD, STIFF STIFFENER, TBD TO BE DETERMINED, TRE TRUSS BEARING ELEVATION, T&G TOP & BOTTOM TONGUE AND GROOVE, TYP TOP OF SLAB/ STEEL / SUBFLOOR, TS THICKENED SLAB ON GRADE, TYP TYPICAL, UNO UNLESS NOTED OTHERWISE, VERT VERTICAL, W WOOD BEAM, WC WOOD COLUMN, WCJ WALL CONTROL JOINT, WHC WOOD HOLLOW (BOX) COLUMN, WSP WOOD STUD PACK/ BUILT-UP COLUMN, WT WEIGHT, HIGH, LOW.

DAG ARCHITECTS logo and contact information: 1223 Airport Road Destin, Florida 32541, 850.837.8152 www.dagarchitects.com

CONSTRUCTION DOCUMENT

DESTIN FORT WALTON BEACH CONVENTION CENTER

EXTERIOR ACCESSIBILITY TASK ORDER NO. 66 - C18-2638-TDD 1250 MIRACLE STRIP PKWY SE FORT WALTON BEACH, FL 32548

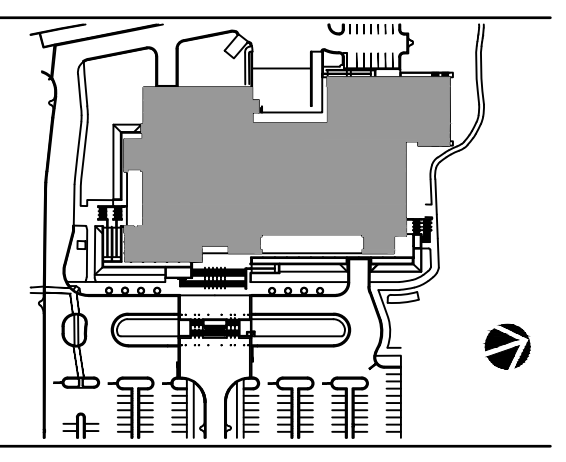

FOR BID ONLY

Table with columns No., Description, and Date for a schedule of values.

STRUCTURAL GENERAL NOTES

O'CONNELL & ASSOCIATES CONSULTING ENGINEERS, L.L.C. logo and address: 1394 Co. Hwy. 283 S. Bldg. #3 Santa Rosa Beach FL 32459

Project number: 17057b Date: 06-12-2020 PIC: NOC PM: JMB

S001

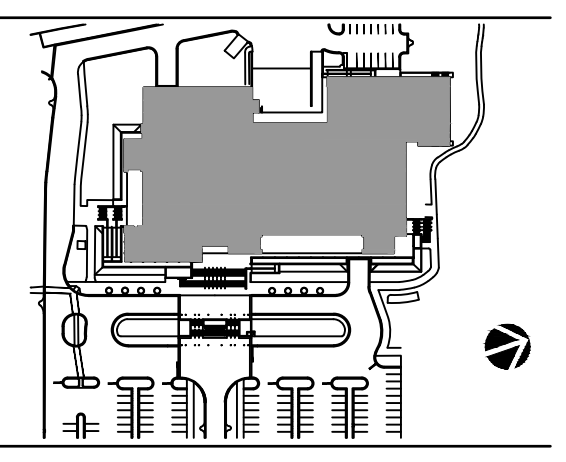

FOR BID ONLY

No.	Description	Date

STRUCTURAL SLAB PLAN

Project number: 17057b
 Date: 06-12-2020
 PIC: NOC
 PM: JMB

S101

O'CONNELL & ASSOCIATES
 CONSULTING ENGINEERS, L.L.C.
CERT. OF AUTH. #30549
 1394 Co. Hwy. 283 S. Bldg. #3 Santa Rosa Beach FL 32459
 (850) 403-4555 www.oconnellengineers.com

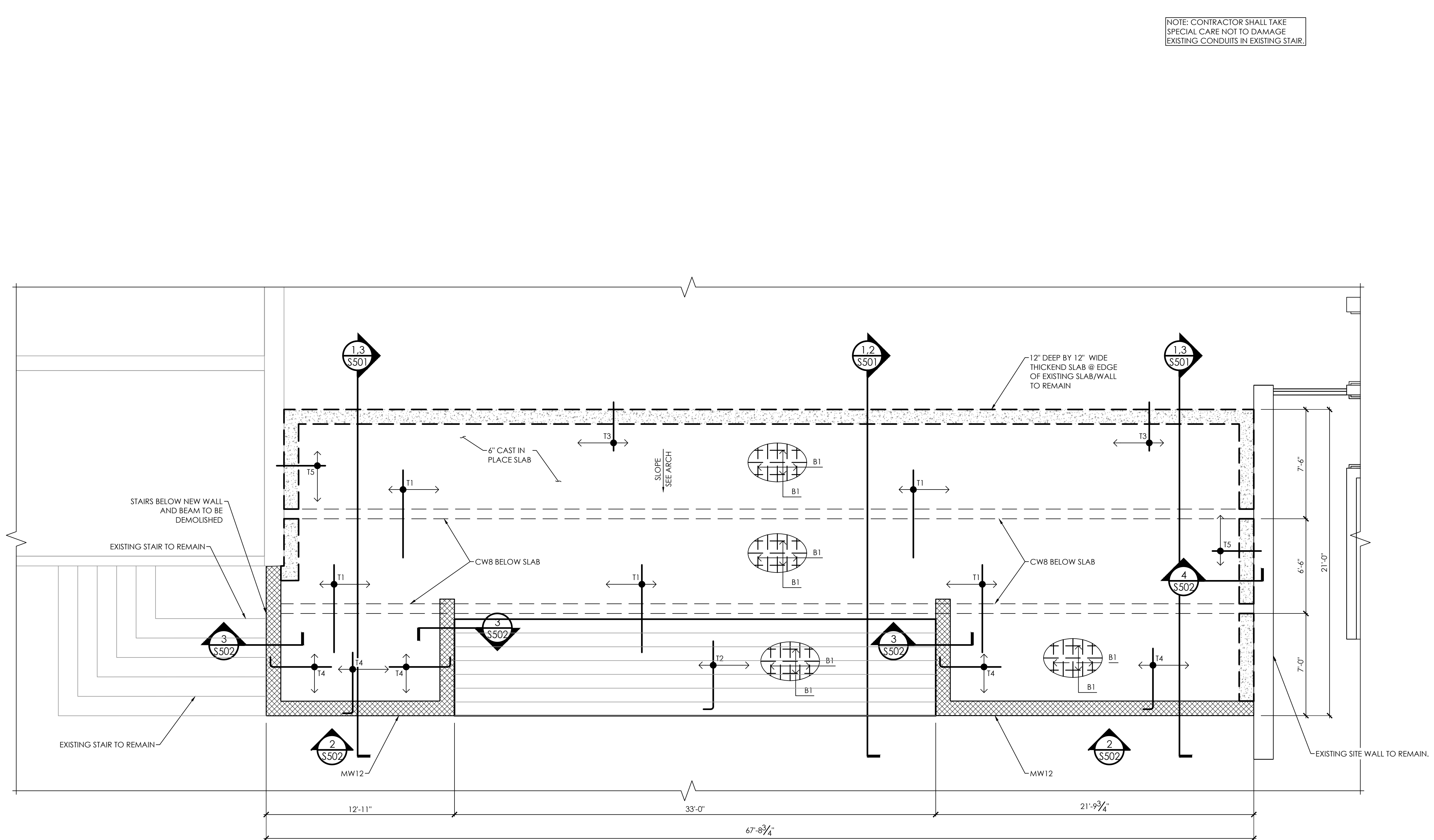

1 MAIN STAIR SLAB PLAN
 SCALE: 1/4"=1'-0"

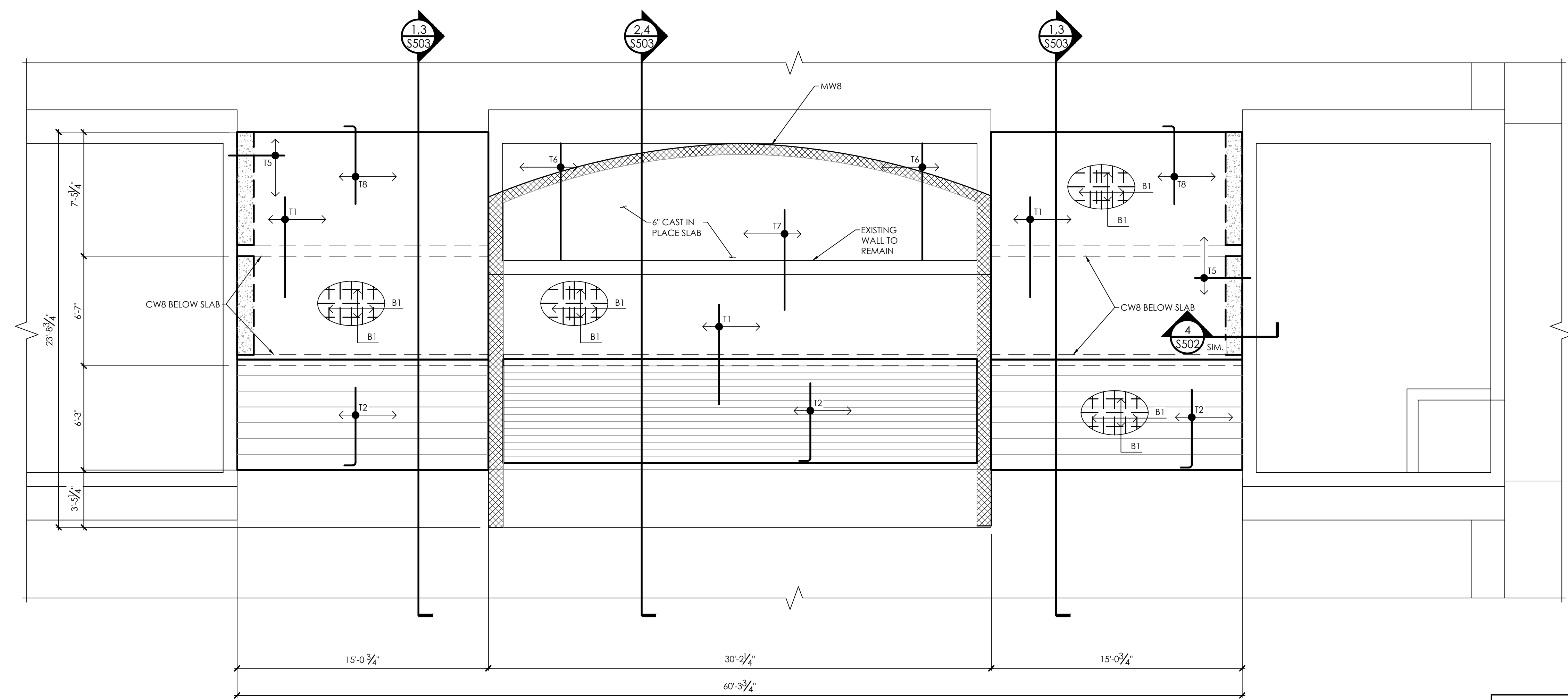

2 FOUNTAIN SLAB PLAN
 SCALE: 1/4"=1'-0"

CONC. SLAB REINF. BAR SCHEDULE

MARK	SIZE	NOTE
B1	#4 BAR @ 10" O/C (MAX.)	BOT. REINF. EA. WAY
T1	#4 X 6'-0" BAR	TOP BAR ABOVE WALL
T2	# 4 X 4'-6" BAR + STD. 90° HOOK	TYP. TOP BAR @ STAIR BASE
T3	#4 X 1'-4" BAR	TOP BAR
T4	# 4 X 4'-0" BAR	TOP BAR
T5	#4 X 3'-0" BAR	TOP BAR
T6	#4 X 7'-0" BAR	TOP BAR
T7	#4 X 6'-0" BAR	TOP BAR
T8	#4 X 4'-0" BAR	TOP BAR BENT AND EPOXIED INTO EXISTING WALL. SEE DETAILS

NOTE:
 1. B# - INDICATES SLAB BOTTOM REINFORCING. BAR SPLICE SHALL BE LOCATED ABOVE STEM WALL.
 2. T# - INDICATES SLAB TOP REINFORCING.
 3. BUNDLED BARS ARE NOT PERMITTED UNLESS APPROVED BY ENGINEER IN RECORD.
 4. SUBSTITUTION OF BAR SIZE/SPACING IS NOT PERMITTED UNLESS APPROVED BY ENGINEER IN RECORD.
 5. CONCRETE FOR SLAB SHALL HAVE MIN. 3000 PSI 28-DAY COMPRESSIVE STRENGTH.
 6. CONCRETE MIXTURE SHALL BE WATERPROOFED WITH **XYPEX ADDITIVE WATERPROOFING PRODUCT**. THE ADDITIVE PRODUCT SHALL BE ADDED TO CONCRETE MIXTURE ON FILM PRIOR TO CONCRETE DELIVERY. CONTRACTOR IS RESPONSIBLE TO OBTAIN PRODUCT SPECIFICATIONS FROM XYPEX MANUFACTURER/SUPPLIER.

- PLAN NOTES:**
- FOR GENERAL NOTES AND DESIGN LIVE LOADS SEE SHEET S001. FOR DETAILS SEE S500 SERIES SHEETS.
 - ALL FOOTING TRENCHES SHOULD BE CLEARED OF ORGANIC MATERIALS.
 - COORDINATE MEP ROUGH INS PRIOR TO CONSTRUCTION.
 - SEE ARCH. DRAWINGS FOR SLOPES, DRAINS, OPENINGS, FLOOR RECESSES AND DIMENSIONS NOT SHOWN. IF A CONFLICT EXISTS, THE ARCH. DIMENSIONS SHALL GOVERN. BOTH ENGINEER AND ARCHITECT OF RECORD SHALL BE NOTIFIED IN WRITING OF ALL CONFLICTS. (SEE CONTRACTOR NOTE BELOW, FOR EXCEPTIONS).
 - CMU WALLS ARE MIN. 8" (NOM.) THICK. SEE TYPICAL WALL REINF. DETAIL FOR REINF. DETAILS.
 - CONTRACTOR SHALL COORDINATE FOOTING STEP LOCATION AND DEPTH WITH POOL SHOP DRAWINGS. SEE TYP. FOOTING STEP DETAIL FOR REINF. LAYOUT & DIMENSIONS.

CONTRACTOR NOTE:
 THESE CONSTRUCTION DOCUMENTS ARE BASED ON ASSUMED EXISTING CONDITIONS. CONTRACTOR SHALL VERIFY ALL FIELD CONDITIONS & DIMENSIONS PRIOR TO CONSTRUCTION. ENGINEER & ARCHITECT OF RECORD SHALL BE NOTIFIED IN WRITING OF ANY DISCREPANCIES.

ALL REPORTS, PLANS, SPECIFICATIONS, COMPUTER FILES, FIELD DATA, NOTES AND OTHER DOCUMENTS AND INSTRUMENTS PREPARED BY THE CONSULTANT SHALL BE THE PROPERTY OF THE CONSULTANT. THE CONSULTANT SHALL RETAIN ALL COMMON LAW, STATUTORY AND OTHER RESERVED RIGHTS, INCLUDING THE COPYRIGHT HEREIN. PURSUANT TO FLORIDA STATUTES, SECTION 556.05(3), AN INDIVIDUAL EMPLOYEE OR AGENT MAY NOT BE HELD INDIVIDUALLY LIABLE FOR NEGLIGENCE.



DAG ARCHITECTS
 DAG Architects, AAC000745
 1223 Airport Road Destin, Florida 32541
 850.837.8152 www.dagarchitects.com

CONSTRUCTION DOCUMENT

DESTIN FORT WALTON BEACH CONVENTION CENTER

EXTERIOR ACCESSIBILITY
 TASK ORDER No. 6b - C18-2638-TDD
 1250 MIRACLE STRIP PKWY SE
 FORT WALTON BEACH, FL 32548

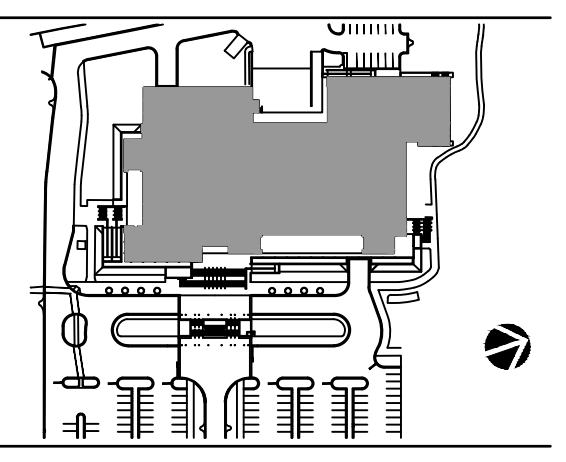

FOR BID ONLY

No.	Description	Date

STRUCTURAL GARAGE STAIR PLANS

Project number: 17057b
 Date: 06-12-2020
 PIC: NOC
 PM: JMB

O'CONNELL & ASSOCIATES
 CONSULTING ENGINEERS, LLC.
CERT. OF AUTH. #30549
 1394 Co. Hwy. 283 S. Bldg. #3 Santa Rosa Beach FL 32459
 (850) 403-4555 www.oconnellengineers.com

S102

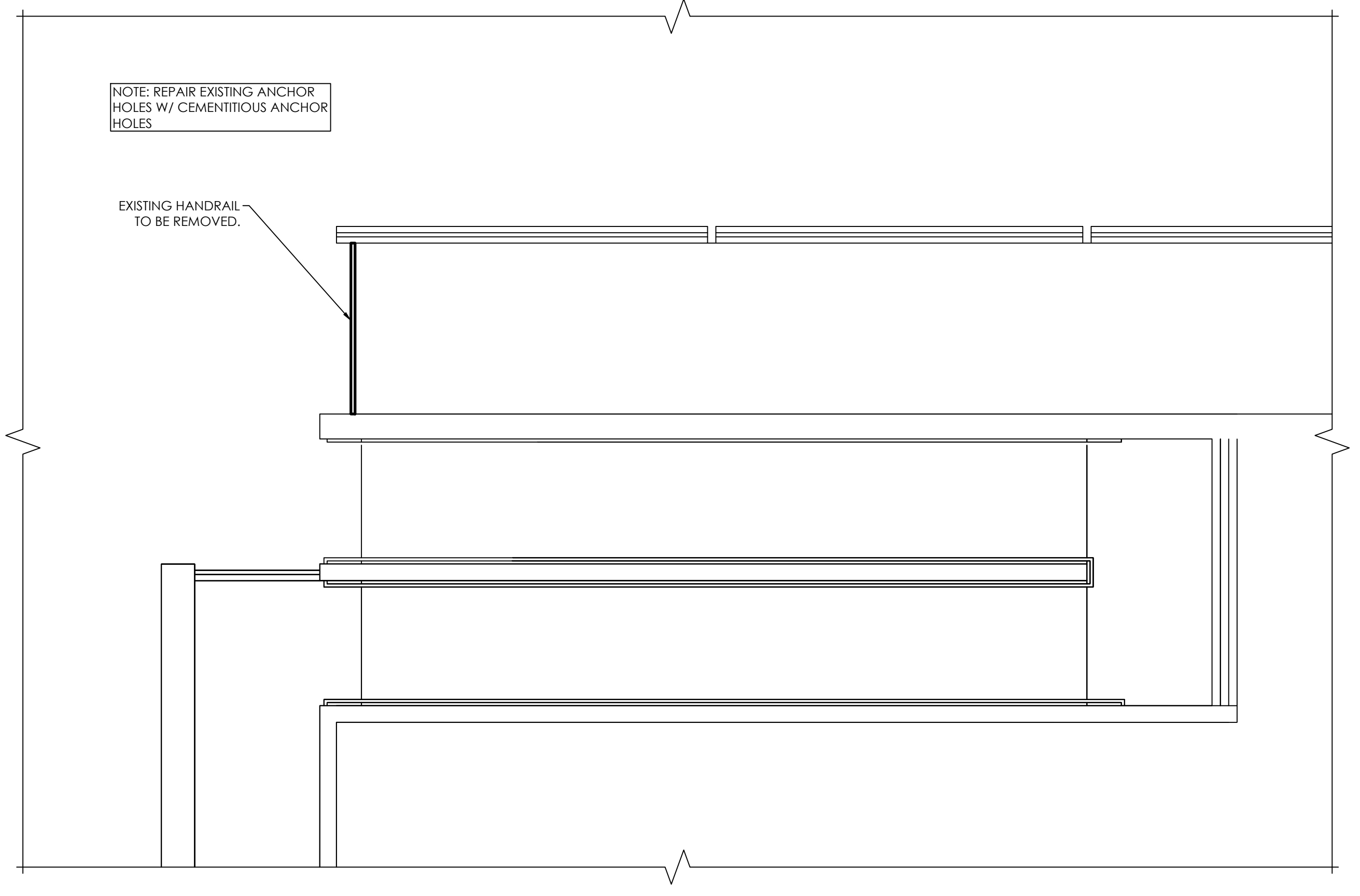

1 GARAGE STAIR DEMO PLAN
 SCALE: 1/4"=1'-0"

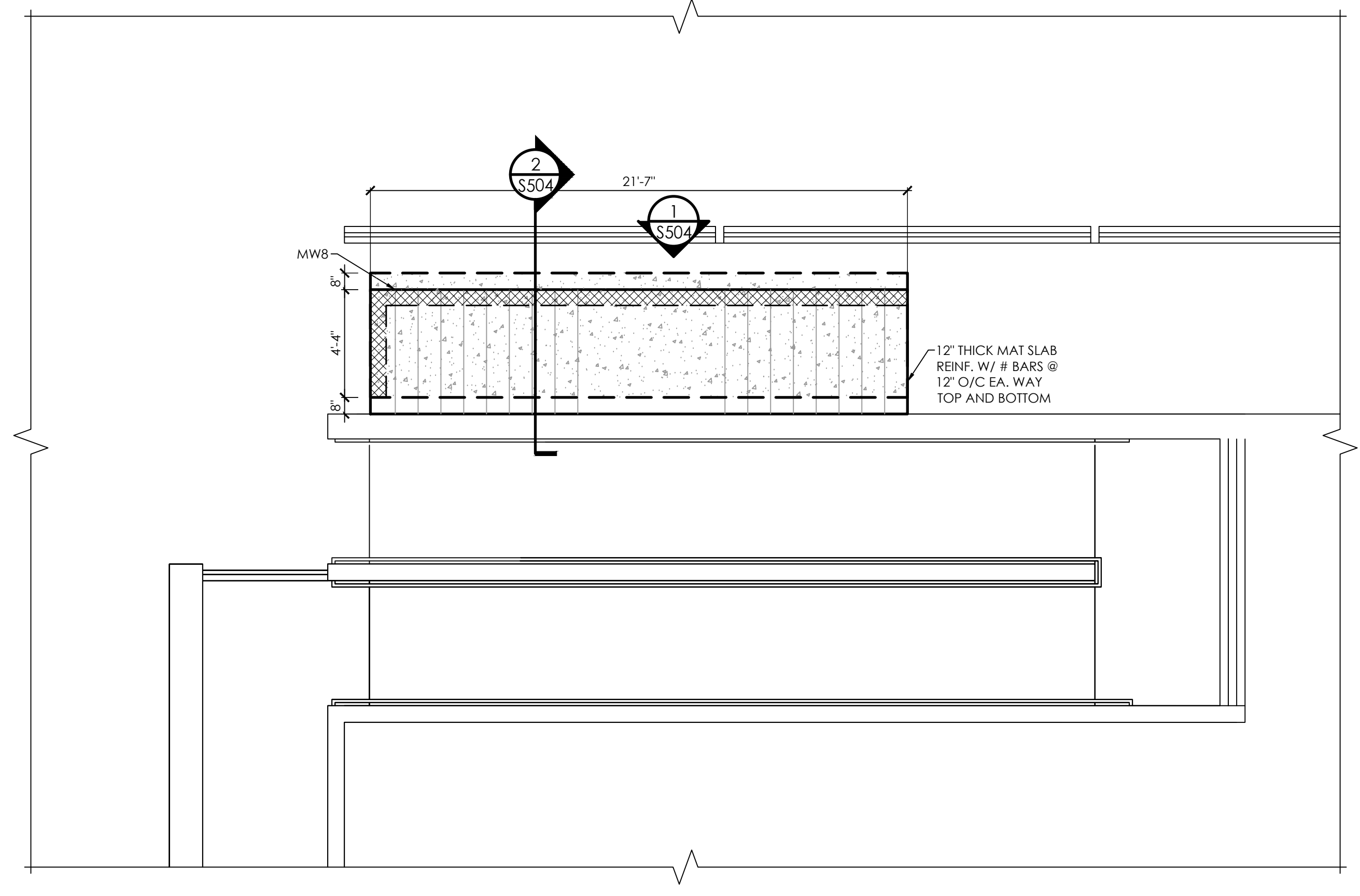

2 GARAGE STAIR FOUNDATION PLAN
 SCALE: 1/4"=1'-0"

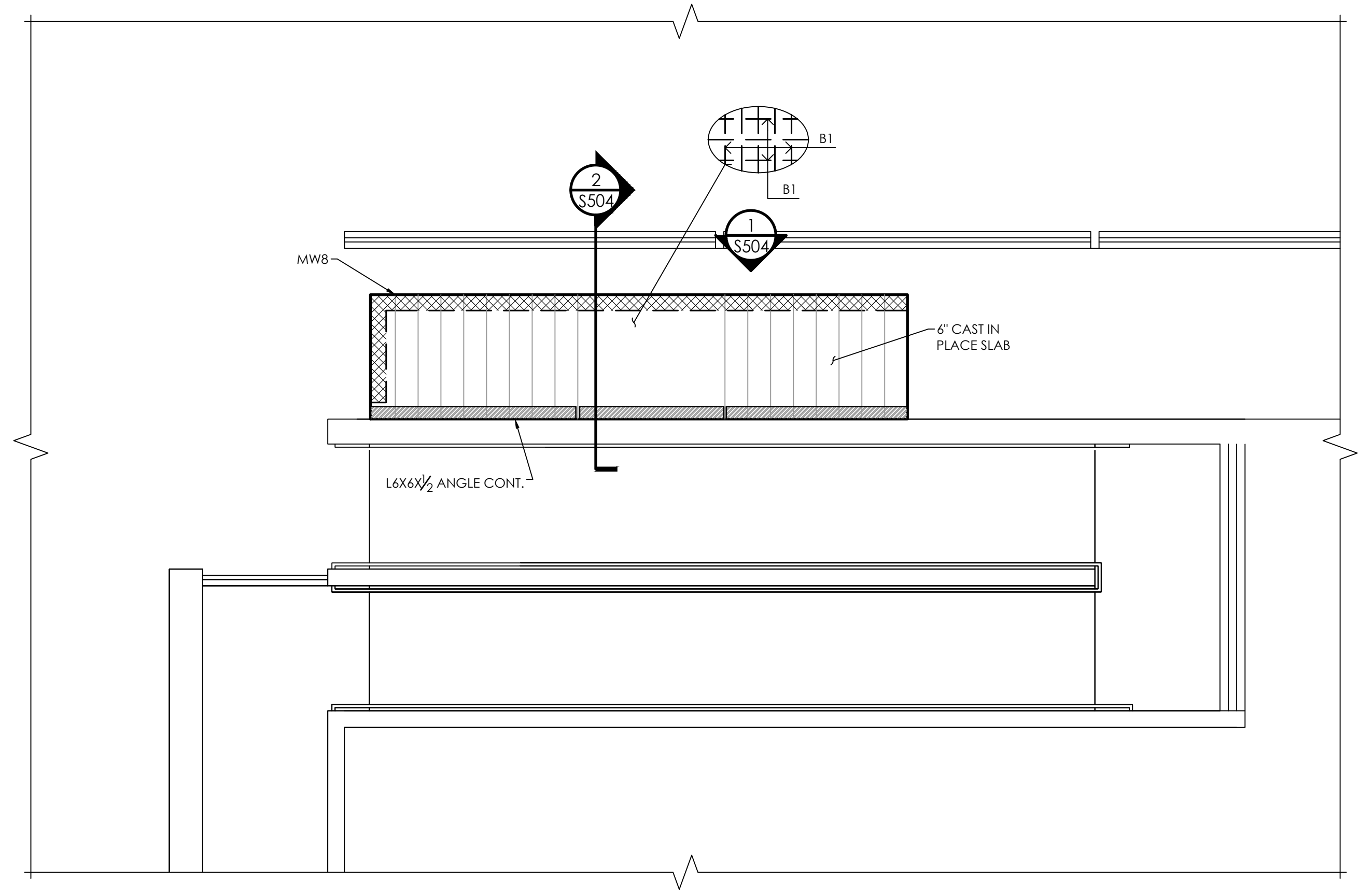

3 GARAGE STAIR SLAB PLAN
 SCALE: 1/4"=1'-0"

CONC. SLAB REINF. BAR SCHEDULE		
MARK	SIZE	NOTE
B1	#4 BAR @ 10" O/C (MAX.)	BOT. REINF. EA. WAY

NOTE:
 1. B# - INDICATES SLAB BOTTOM REINFORCING.
 BAR SPICE SHALL BE LOCATED ABOVE STEM WALL FOR DETAILS SEE S500 SERIES SHEETS.
 2. T# - INDICATES SLAB TOP REINFORCING
 3. BUNDLED BARS ARE NOT PERMITTED UNLESS APPROVED BY ENGINEER IN RECORD
 4. SUBSTITUTION OF BAR SIZE/SPACING IS NOT PERMITTED UNLESS APPROVED BY ENGINEER IN RECORD
 5. CONCRETE FOR SLAB SHALL HAVE MIN. 3000 PSI 28-DAY COMPRESSIVE STRENGTH.
 6. CONCRETE MIXTURE SHALL BE WATERPROOFED WITH **XYPEX ADDITIVE WATERPROOFING PRODUCT**. THE ADDITIVE PRODUCT SHALL BE ADDED TO CONCRETE MIXTURE ON PLAN PRIOR TO CONCRETE DELIVERY. CONTRACTOR IS RESPONSIBLE TO OBTAIN PRODUCT SPECIFICATIONS FROM XYPEX MANUFACTURER/SUPPLIER.

FOUNDATION PLAN NOTES:

- FOR GENERAL NOTES AND DESIGN LIVE LOADS SEE SHEET S001. FOR DETAILS SEE S500 SERIES SHEETS.
- ALL FOOTING TRENCHES SHOULD BE CLEARED OF ORGANIC MATERIALS.
- COORDINATE MEP ROUGH INS PRIOR TO CONSTRUCTION
- TOP OF FOOTING TO BE PLACED MINIMUM 8" BELOW FINISHED GRADE.
- SEE ARCH. DRAWINGS FOR SLOPES, DRAINS, OPENINGS, FLOOR RECESSES AND DIMENSIONS NOT SHOWN. IF A CONFLICT EXISTS, THE ARCH. DIMENSIONS SHALL GOVERN, BOTH ENGINEER AND ARCHITECT OF RECORD SHALL BE NOTIFIED IN WRITING OF ALL CONFLICTS. (SEE CONTRACTOR NOTE BELOW, FOR EXCEPTION).
- CMU WALLS ARE MIN. 8" (NOM.) THICK. SEE TYPICAL WALL REINF. DETAIL FOR REINF. DETAILS.
- SEE DETAILS FOR FOOTING REINF. REQ.

CONTRACTOR NOTE:

THESE CONSTRUCTION DOCUMENTS ARE BASED ON ASSUMED EXISTING CONDITIONS. CONTRACTOR SHALL VERIFY ALL FIELD CONDITIONS & DIMENSIONS PRIOR TO CONSTRUCTIONS. ENGINEER & ARCHITECT OF RECORD SHALL BE NOTIFIED IN WRITING OF ANY DISCREPANCIES. CONTRACTOR SHALL VERIFY ALL DIMENSIONS SHOWN WITH ARCHITECTURAL DRAWINGS

ALL REPORTS, PLANS, SPECIFICATIONS, COMPUTER FILES, FIELD DATA, NOTES AND OTHER DOCUMENTS AND INSTRUMENTS PREPARED BY THE CONSULTANT SHALL REMAIN THE PROPERTY OF THE CONSULTANT. THE CONSULTANT SHALL RETAIN ALL COMMON LAW, STATUTORY AND OTHER RESERVED RIGHTS, INCLUDING THE COPYRIGHT THEREIN. PURSUANT TO FLORIDA STATUTES, SECTION 556.003, AN INDIVIDUAL EMPLOYEE OR AGENT MAY NOT BE HELD INDIVIDUALLY LIABLE FOR NEGLIGENCE.



DAG ARCHITECTS
DAG Architects, AAC000745
1223 Airport Road Destin, Florida 32541
850.837.8152 www.dagarchitects.com

CONSTRUCTION DOCUMENT

DESTIN FORT WALTON BEACH CONVENTION CENTER

EXTERIOR ACCESSIBILITY
TASK ORDER No. 6b - C18-2638-TDD
1250 MIRACLE STRIP PKWY SE
FORT WALTON BEACH, FL 32548

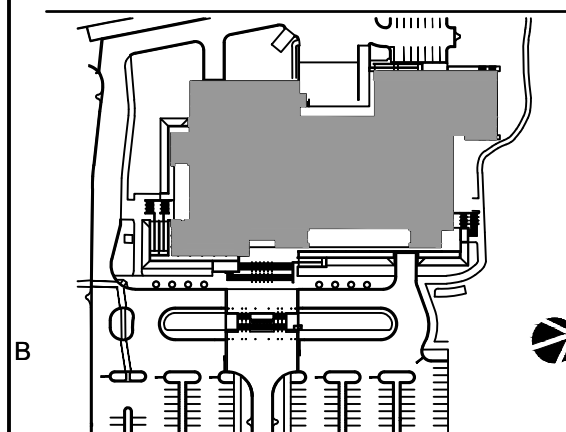

FOR BID ONLY

No.	Description	Date

STRUCTURAL DETAILS

Project number: 17057b
Date: 06-12-2020
PIC: NOC
PM: JMB

S501

O'CONNELL & ASSOCIATES
CONSULTING ENGINEERS, LLC.
CER. OF AUTH. #30549
1394 Co. Hwy. 283 S. Bldg. #3 Santa Rosa Beach FL 32459
(850) 433-4555 www.oconnellengineers.com

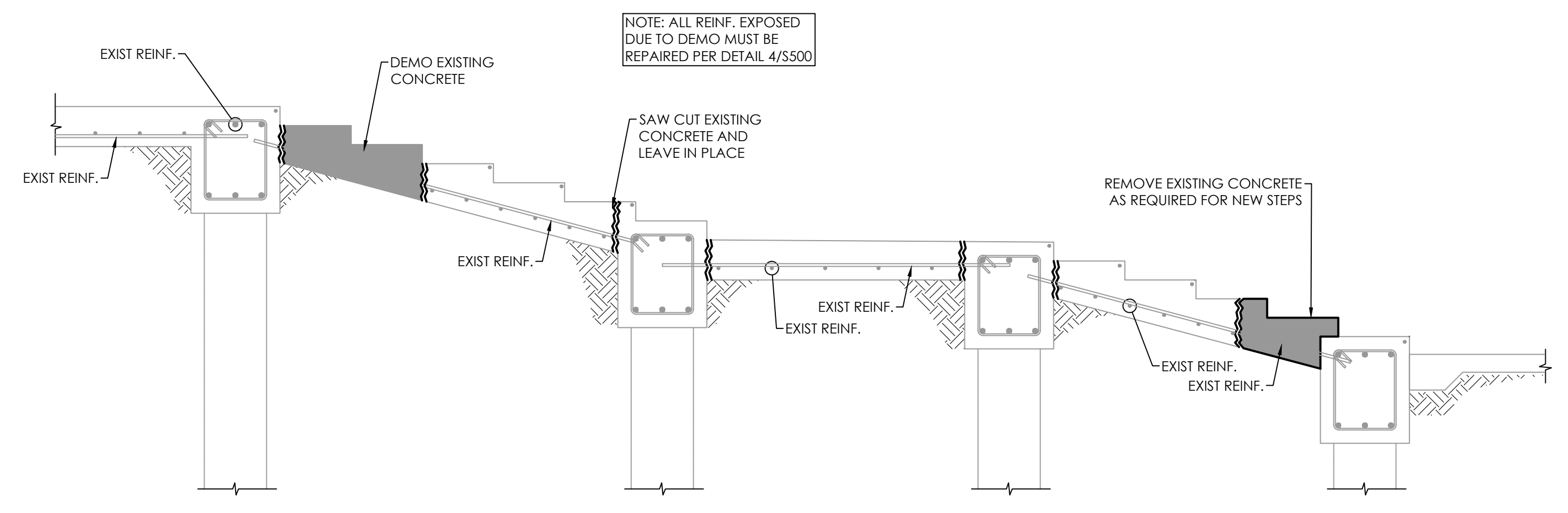

1 MAIN STAIR DEMO PLAN
SCALE: 1/2"=1'-0"

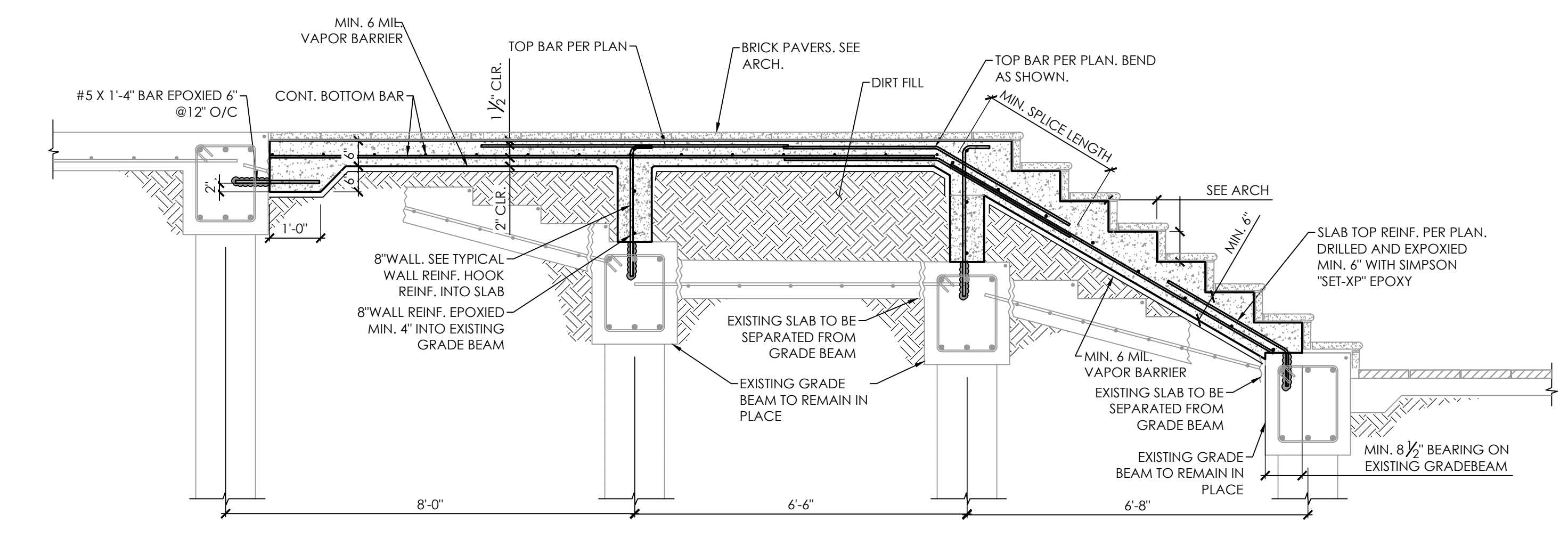

2 NEW MAIN STAIR SECTION
SCALE: 1/2"=1'-0"

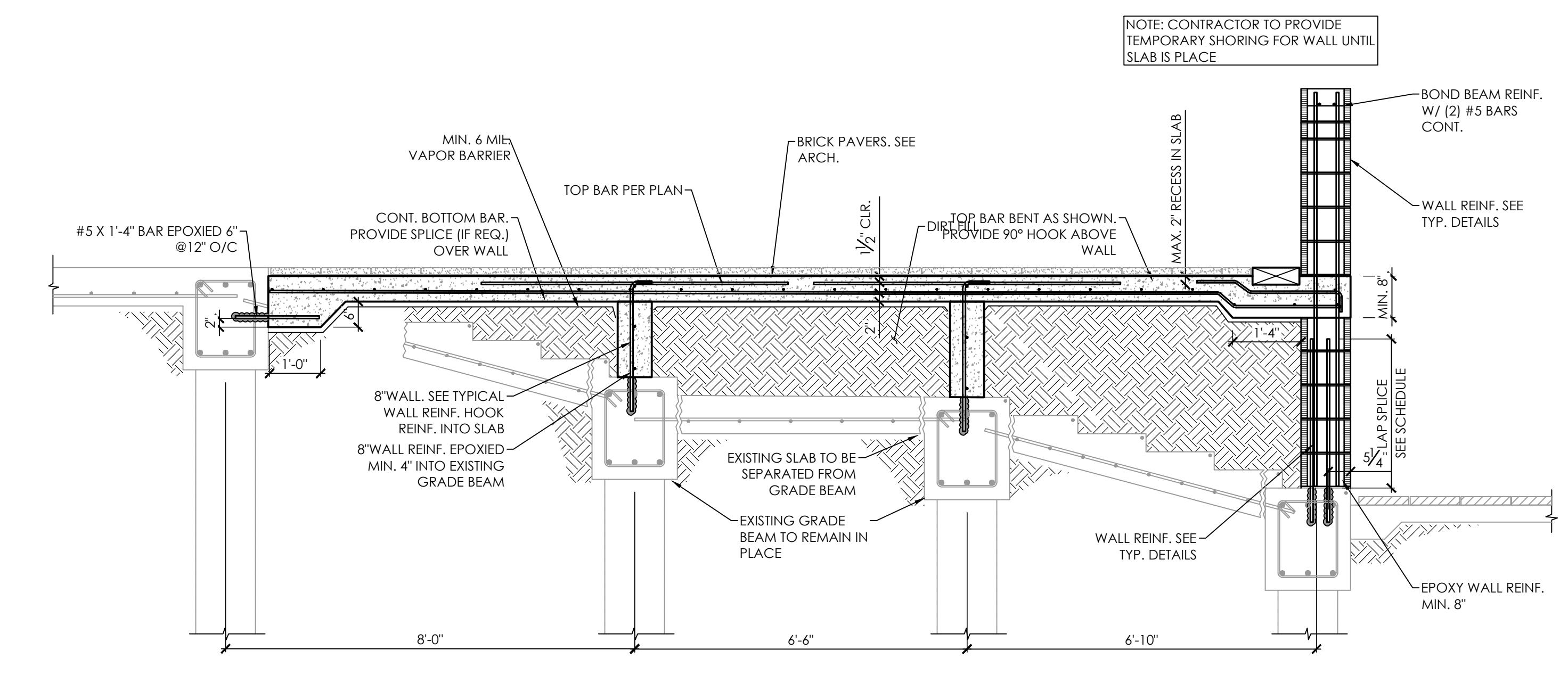

3 NEW MAIN STAIR @ GUARD RAIL
SCALE: 1/2"=1'-0"

ALL REPORTS, PLANS, SPECIFICATIONS, COMPUTER FILES, FIELD DATA, NOTES AND OTHER DOCUMENTS AND INSTRUMENTS PREPARED BY THE CONSULTANT SHALL REMAIN THE PROPERTY OF THE CONSULTANT. THE CONSULTANT SHALL RETAIN ALL COMMON LAW, STATUTORY AND OTHER RIGHTS IN ANY PATENTABLE INVENTIONS OR DISCOVERIES MADE BY THE CONSULTANT OR ANY OF ITS EMPLOYEES OR AGENTS. NO PART OF THIS DOCUMENT SHALL BE REPRODUCED OR TRANSMITTED IN ANY FORM OR BY ANY MEANS, ELECTRONIC OR MECHANICAL, INCLUDING PHOTOCOPYING, RECORDING, OR BY ANY INFORMATION STORAGE AND RETRIEVAL SYSTEM, WITHOUT THE WRITTEN PERMISSION OF THE CONSULTANT. THIS DOCUMENT IS THE PROPERTY OF O'CONNELL & ASSOCIATES, LLC. ANY UNAUTHORIZED REPRODUCTION OR TRANSMISSION IS STRICTLY PROHIBITED. O'CONNELL & ASSOCIATES, LLC. 1394 CO. HWY. 283 S. BLDG. #3 SANTA ROSA BEACH, FL 32459. (850) 433-4555. WWW.OCONNELLENGINEERS.COM



DAG ARCHITECTS
DAG Architects, AAC000745
1223 Airport Road Destin, Florida 32541
850.837.8152 www.dagarchitects.com

CONSTRUCTION DOCUMENT

DESTIN FORT WALTON BEACH CONVENTION CENTER
EXTERIOR ACCESSIBILITY
TASK ORDER No. 6b - C18-2638-TDD
1250 MIRACLE STRIP PKWY SE
FORT WALTON BEACH, FL 32548

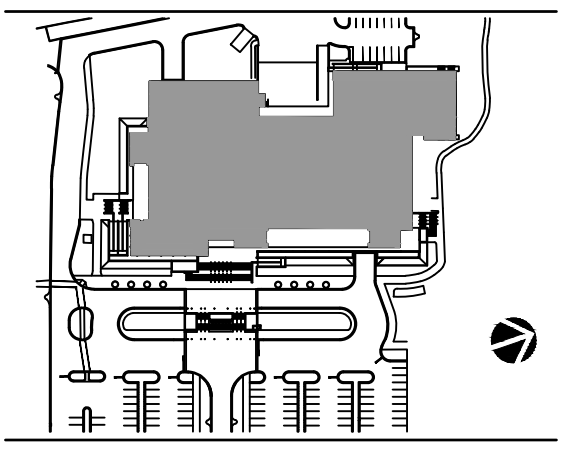

FOR BID ONLY

No.	Description	Date

STRUCTURAL DETAILS

Project number: 17057b
Date: 06-12-2020
PIC: NOC
PM: JMB

S502

O'CONNELL & ASSOCIATES
CONSULTING ENGINEERS, L.L.C.
CERT. OF AUTH. #30549
1394 Co. Hwy. 283 S. Bldg. #3 Santa Rosa Beach FL 32459
(850) 403-4555 www.oconnellengineers.com

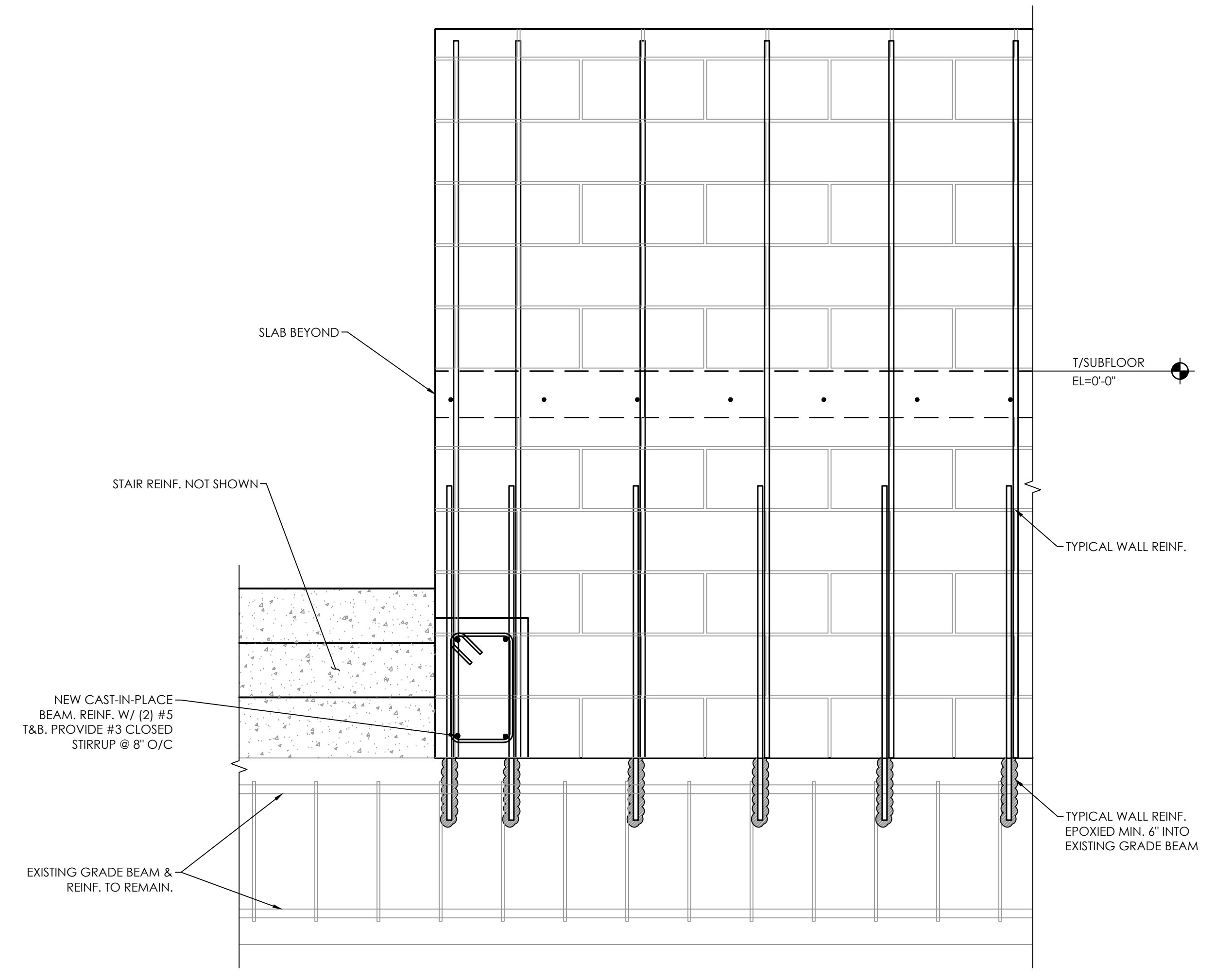

2 NEW WALL ON EXISTING GRADEBEAM
SCALE: N.T.S.

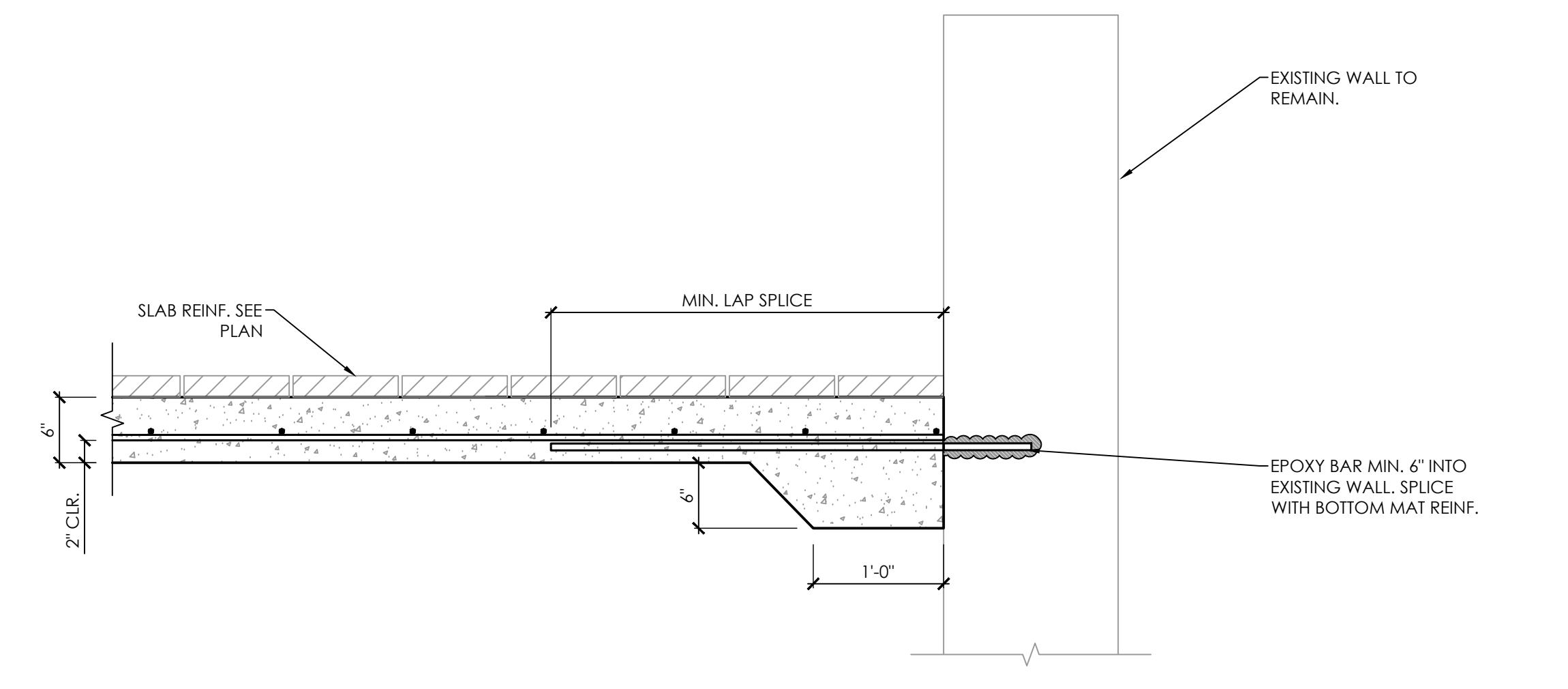

4 THICKEND EDGE @ EXISTING WALL
SCALE: N.T.S.

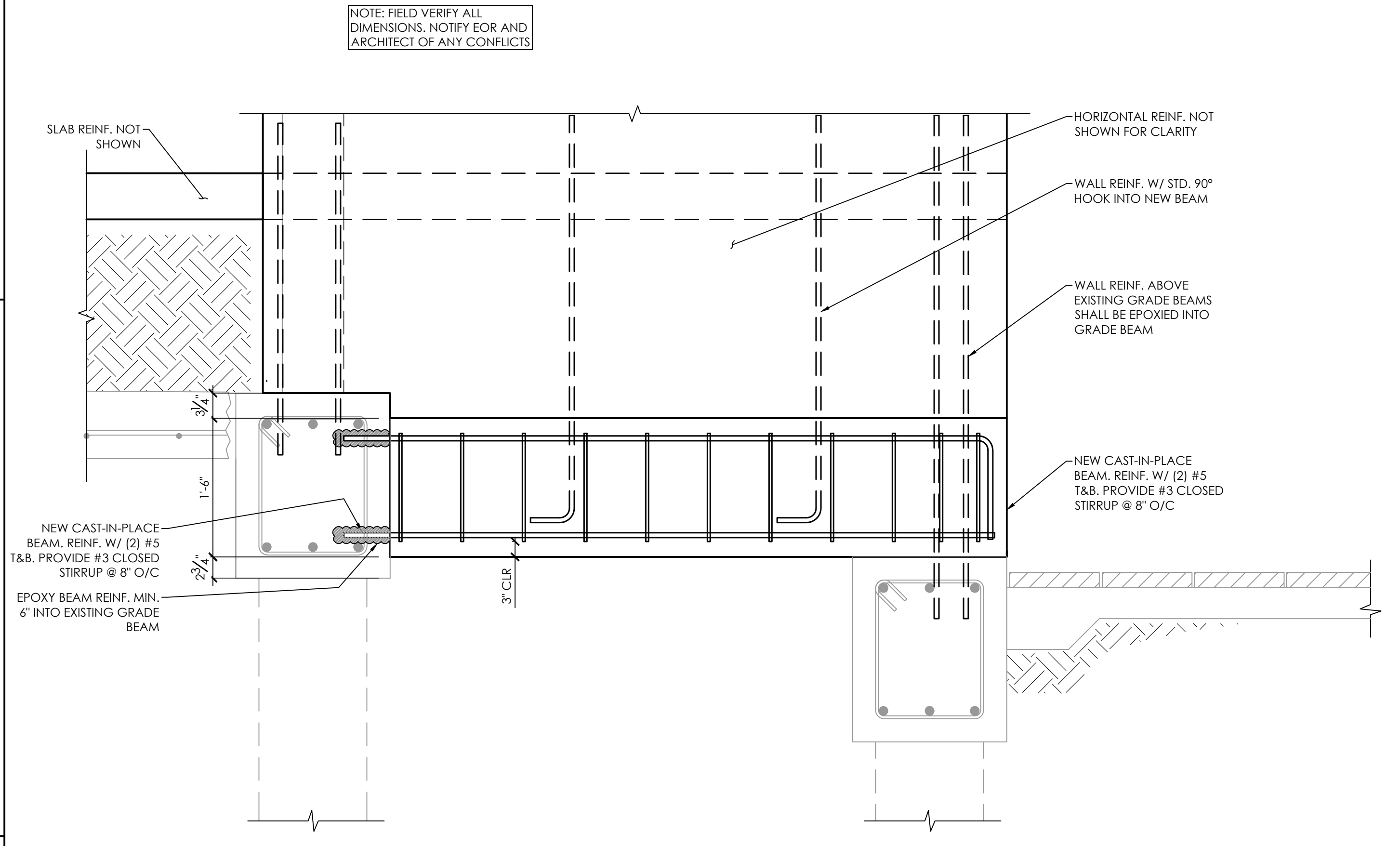

1 NEW BEAM & WALL @ STAIR EDGE ELEVATION VIEW
SCALE: N.T.S.

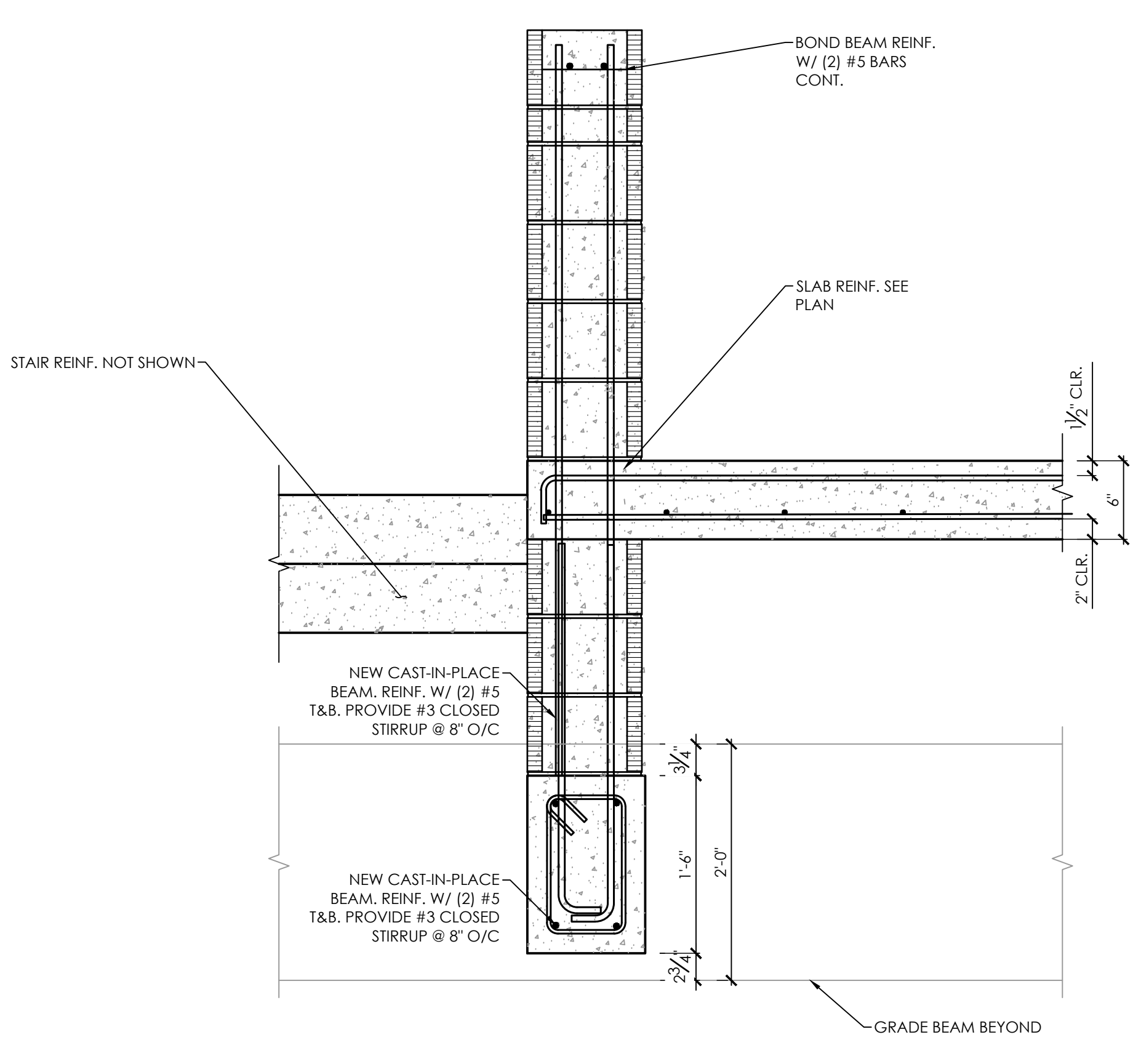

3 NEW BEAM & WALL @ STAIR EDGE SECTION VIEW
SCALE: N.T.S.



DAG ARCHITECTS
DAG Architects, AAC000745
1223 Airport Road Destin, Florida 32541
850.837.8152 www.dagarchitects.com

CONSTRUCTION DOCUMENT

DESTIN FORT WALTON BEACH CONVENTION CENTER

EXTERIOR ACCESSIBILITY
TASK ORDER No. 6b - C18-2638-TDD
1250 MIRACLE STRIP PKWY SE
FORT WALTON BEACH, FL 32548

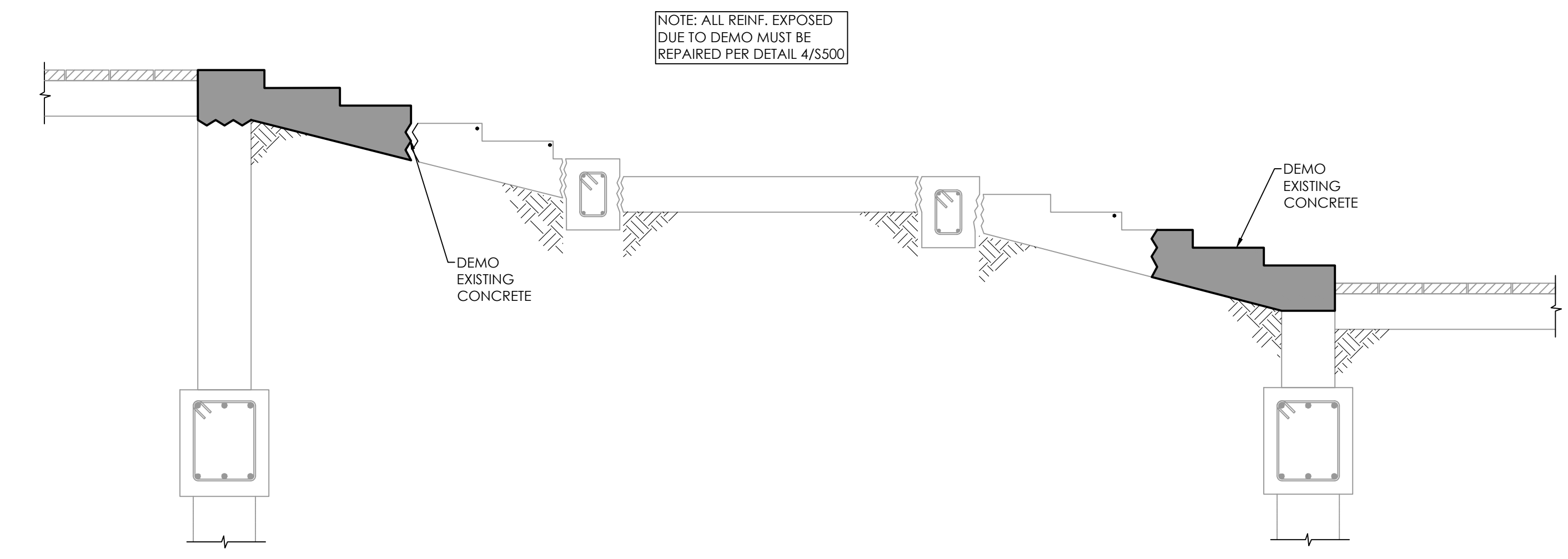

1 FOUNTAIN STAIR DEMO PLAN
SCALE: 1/2"=1'-0"

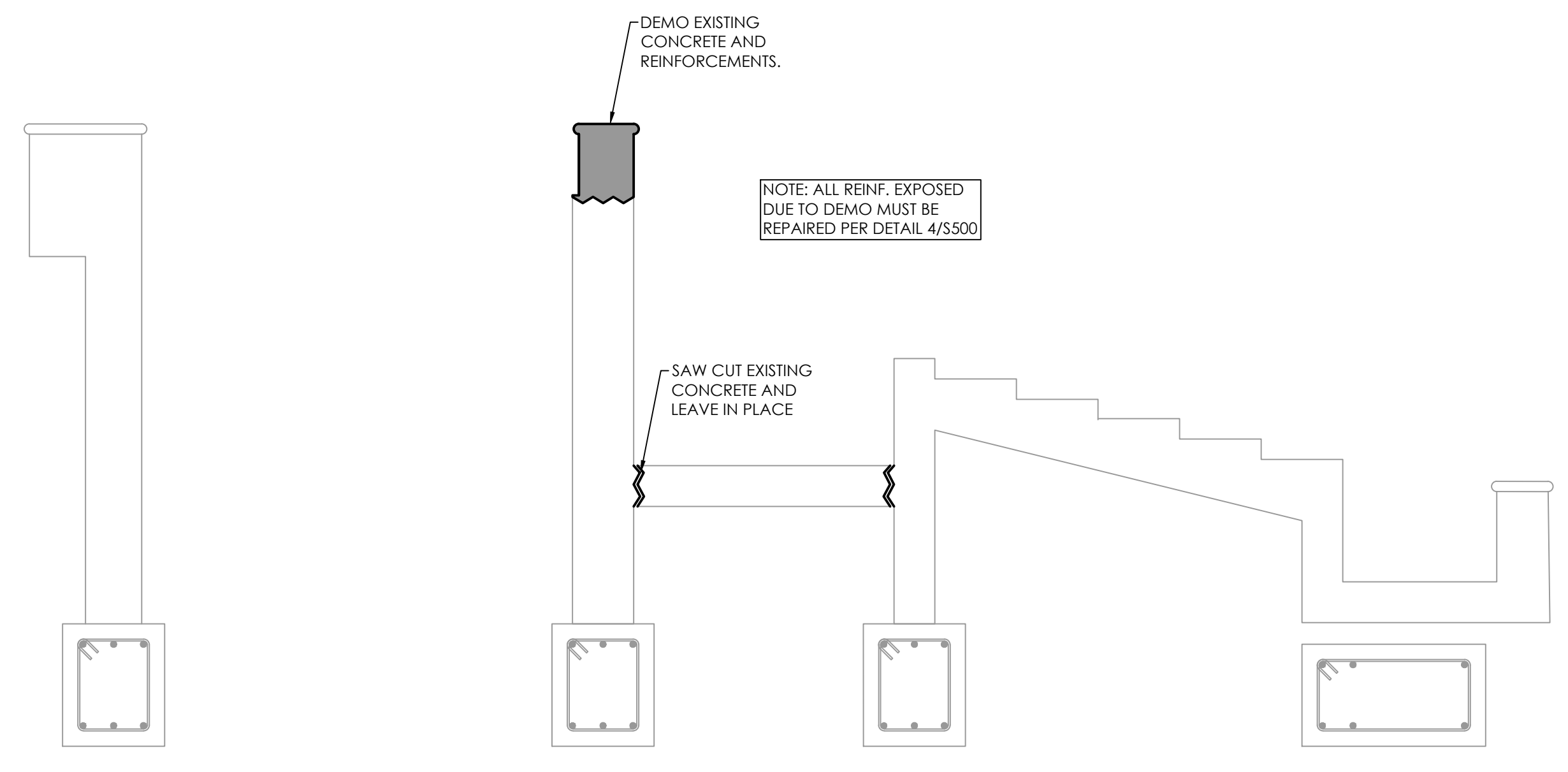

2 FOUNTAIN DEMO PLAN
SCALE: 1/2"=1'-0"

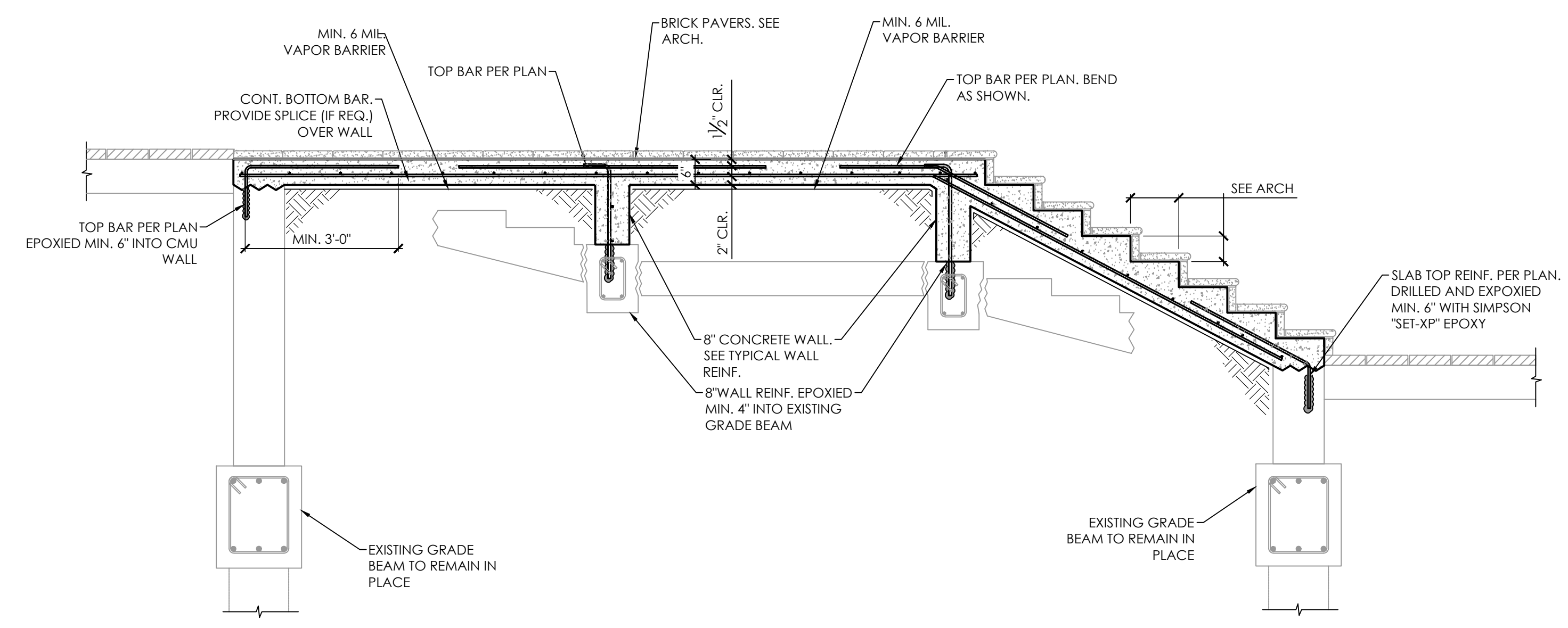

3 NEW FOUNTAIN STAIR SECTION
SCALE: 1/2"=1'-0"

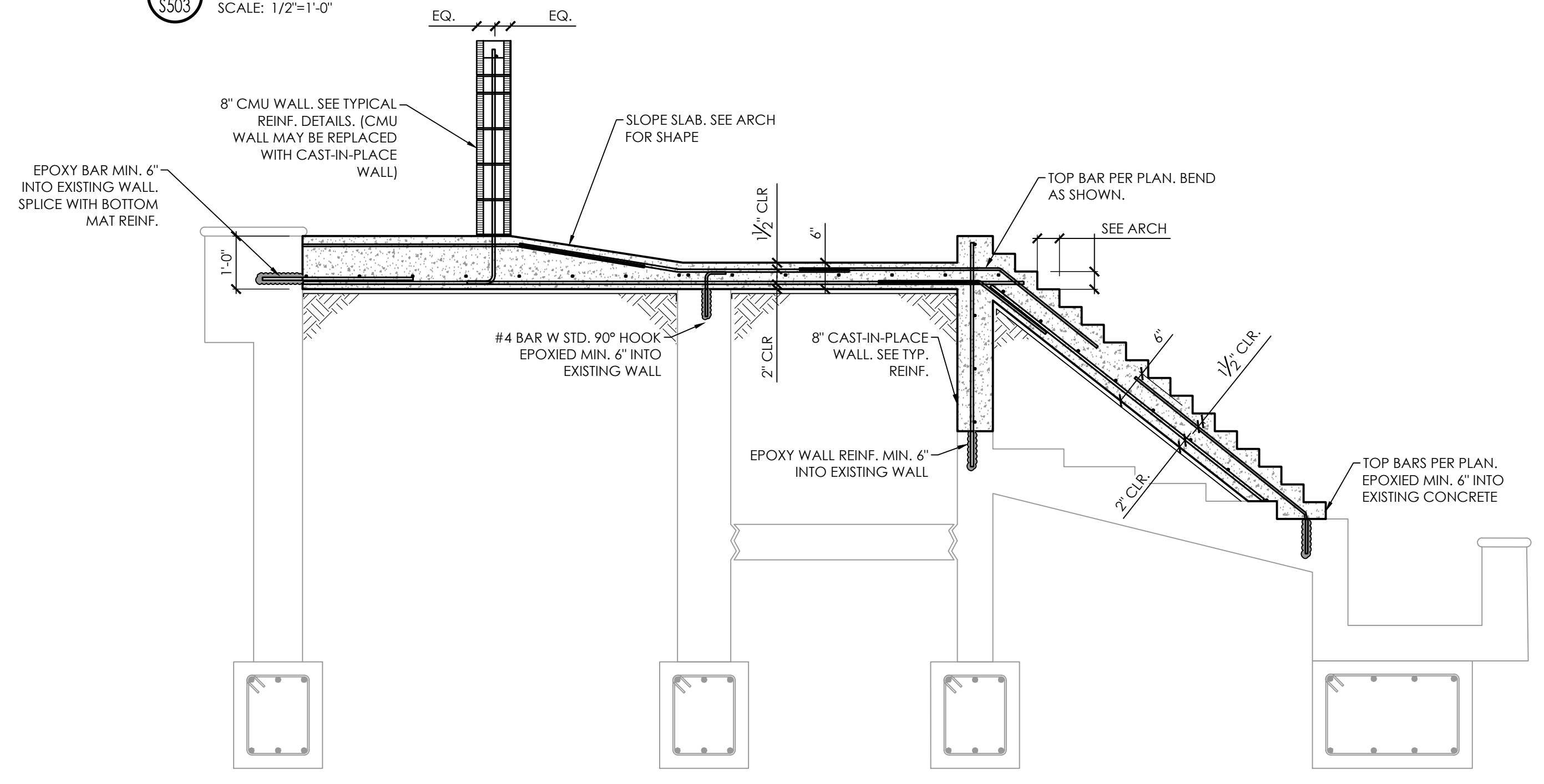

4 NEW FOUNTAIN SECTION
SCALE: 1/2"=1'-0"

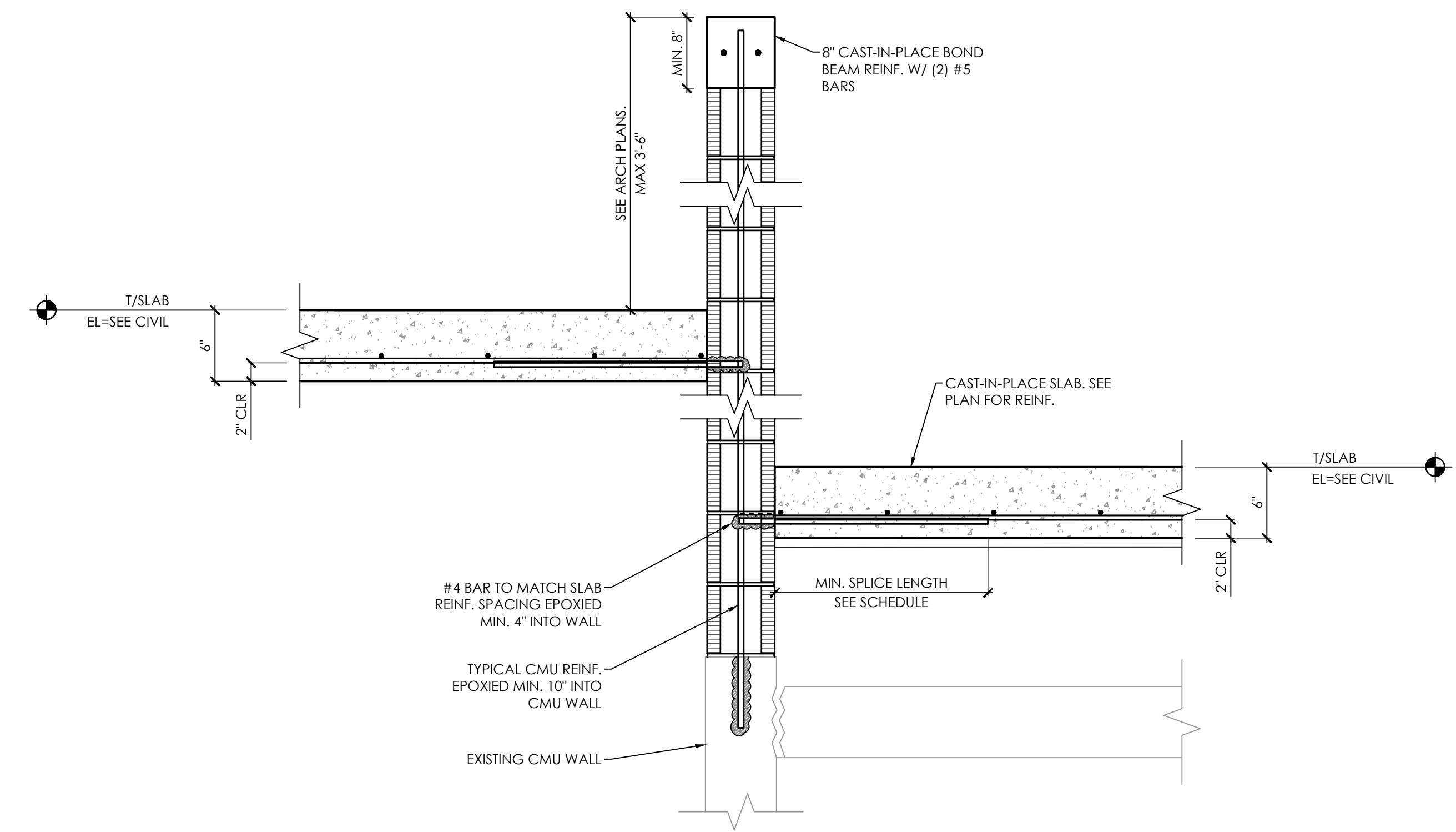

5 NEW FOUNTAIN WALL SECTION
SCALE: N.T.S.

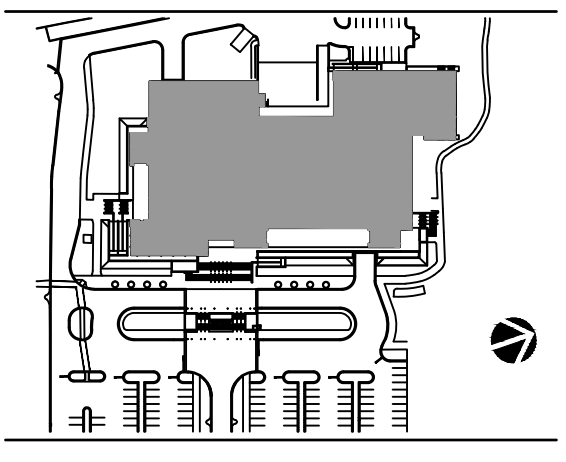

FOR BID ONLY

No.	Description	Date

STRUCTURAL DETAILS

O'CONNELL & ASSOCIATES
CONSULTING ENGINEERS, L.L.C.
CERT. OF AUTH. #30549
1394 Co. Hwy. 283 S. Bldg. #3 Santa Rosa Beach FL 32459
(850) 433-4555 www.oconnellengineers.com

Project number: 17057b
Date: 06-12-2020
PIC: NOC
PM: JMB

S503

ALL REPORTS, PLANS, SPECIFICATIONS, COMPUTER FILES, FIELD DATA, NOTES AND OTHER DOCUMENTS AND INSTRUMENTS PREPARED BY THE CONSULTANT SHALL REMAIN THE PROPERTY OF THE CONSULTANT. THE CONSULTANT SHALL RETAIN ALL COMMON LAW, STATUTORY AND OTHER RIGHTS IN ANY AND ALL INTELLECTUAL PROPERTY RIGHTS IN ANY AND ALL SUCH DOCUMENTS AND INSTRUMENTS. NO PART OF THIS DOCUMENT SHALL BE REPRODUCED OR TRANSMITTED IN ANY FORM OR BY ANY MEANS, ELECTRONIC OR MECHANICAL, INCLUDING PHOTOCOPYING, RECORDING, OR BY ANY INFORMATION STORAGE AND RETRIEVAL SYSTEM, WITHOUT THE WRITTEN PERMISSION OF THE CONSULTANT. THIS DOCUMENT IS THE PROPERTY OF O'CONNELL & ASSOCIATES, L.L.C. AND IS NOT TO BE REPRODUCED OR TRANSMITTED IN ANY FORM OR BY ANY MEANS, ELECTRONIC OR MECHANICAL, INCLUDING PHOTOCOPYING, RECORDING, OR BY ANY INFORMATION STORAGE AND RETRIEVAL SYSTEM, WITHOUT THE WRITTEN PERMISSION OF O'CONNELL & ASSOCIATES, L.L.C.



DAG ARCHITECTS
 DAG Architects, AAC000745
 1223 Airport Road Destin, Florida 32541
 850.837.8152 www.dagarchitects.com

CONSTRUCTION DOCUMENT

DESTIN FORT WALTON BEACH CONVENTION CENTER

EXTERIOR ACCESSIBILITY
 TASK ORDER No. 6b - C18-2638-TDD
 1250 MIRACLE STRIP PKWY SE
 FORT WALTON BEACH, FL 32548

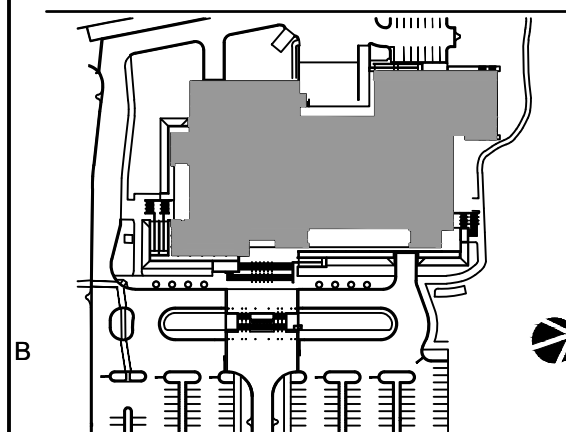

FOR BID ONLY

No.	Description	Date

STRUCTURAL DETAILS

Project number: 17057b
 Date: 06-12-2020
 PIC: NOC
 PM: JMB

O'CONNELL & ASSOCIATES
 CONSULTING ENGINEERS, L.L.C.
CERT. OF AUTH. #30549
 1394 Co. Hwy. 283 S. Bldg. #3 Santa Rosa Beach FL 32459
 (850) 463-6555 www.oconnellengineers.com

S504

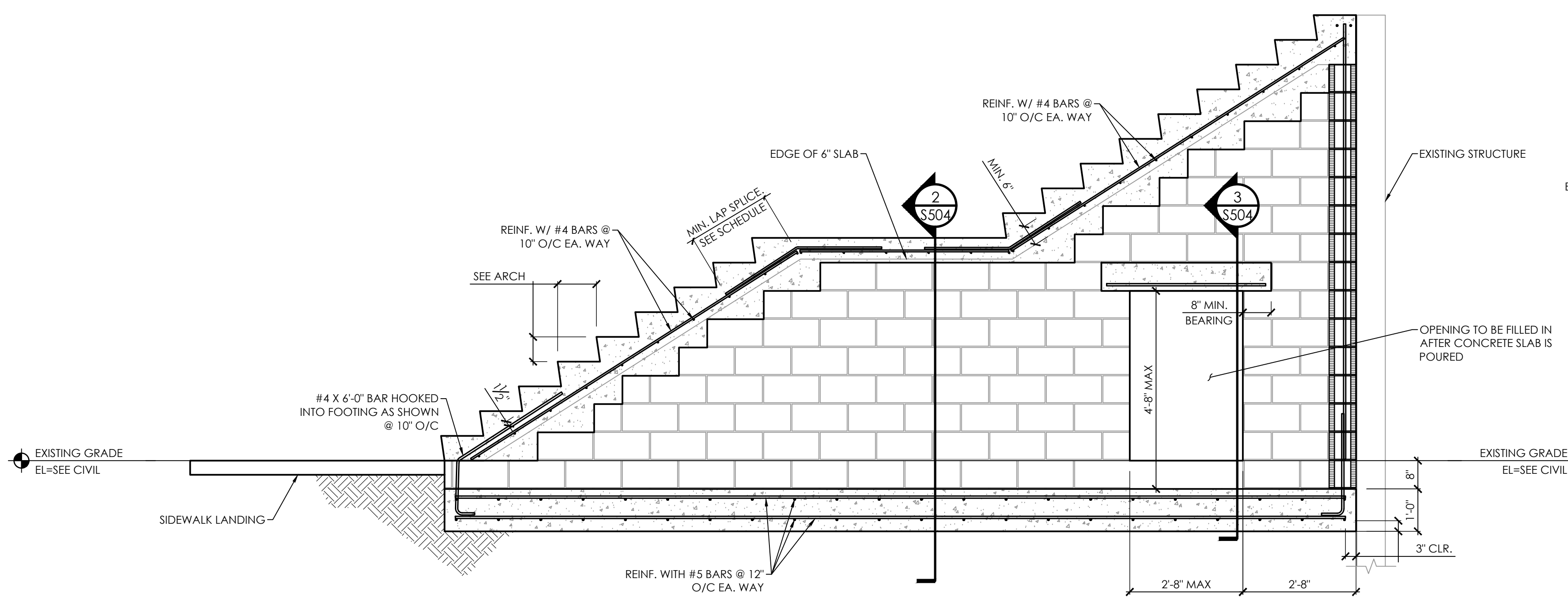

1 GARAGE STAIR ELEVATION
 S504 SCALE: 1/2"=1'-0"

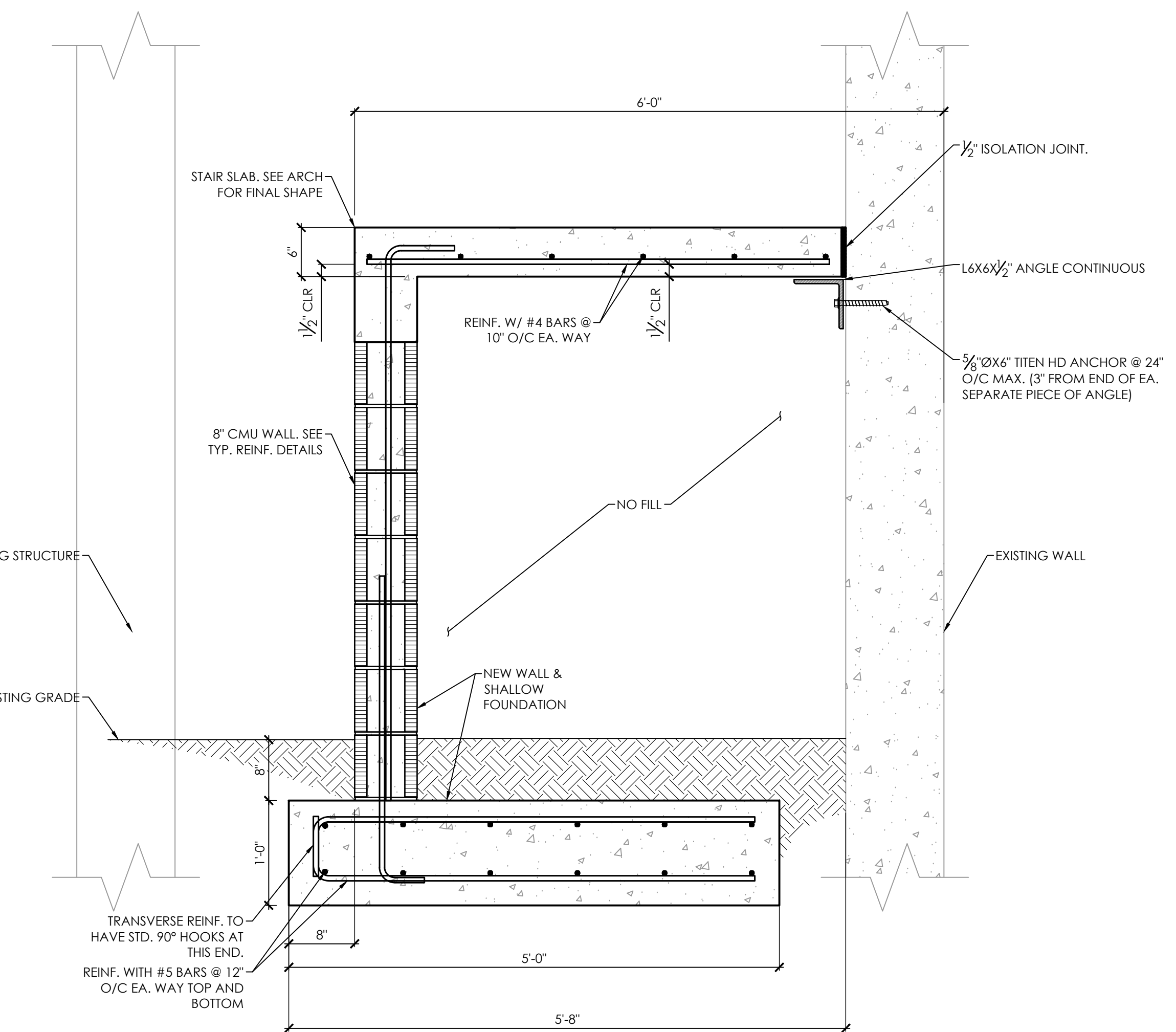

2 GARAGE STAIR SECTION
 S504 SCALE: 1"=1'-0"

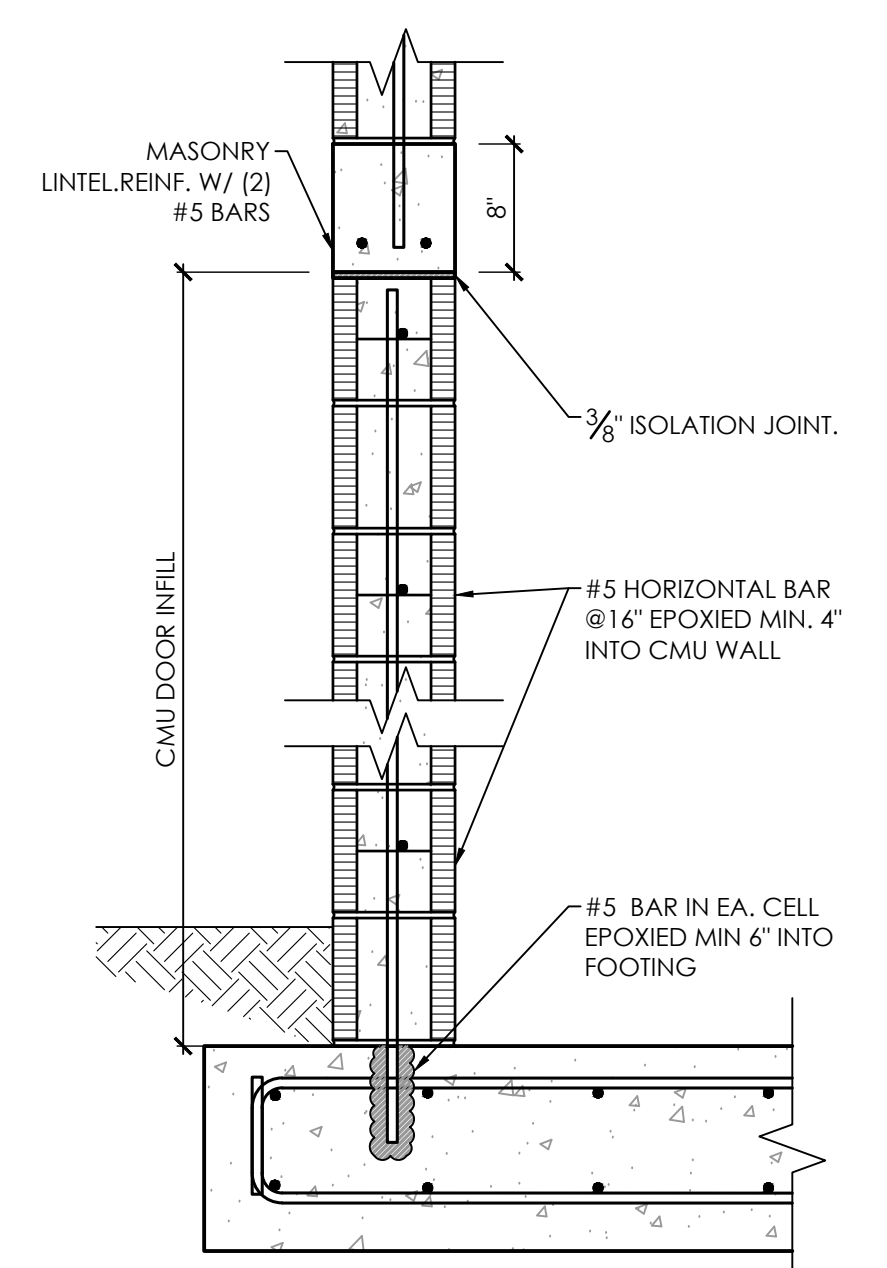

3 DOOR INFILL DETAIL
 S504 SCALE: 1"=1'-0"

LEGEND

- FW FIRE WATER SUPPLY
- PW POTABLE WATER SUPPLY
- SPRINKLER HEAD
- POINT OF CONNECTION TO EXISTING

SHEET NOTES

- ① EXISTING SPRINKLER HEAD SHALL REMAIN IN PLACE. PROTECT DURING COURSE OF CONSTRUCTION.
- ② PROVIDE NEW SPRINKLER HEADS TO PROTECT NEW SPACE. HEADS SHALL MATCH EXISTING STYLE.

GENERAL NOTES

1. IT IS NOTED THAT SOME AREAS WILL BE REQUIRED TO BE PROTECTED AS ORDINARY HAZARD (MECHANICAL ROOMS, ETC.) THESE AREAS HAVE BEEN IDENTIFIED BY A DIFFERENT HATCHING PATTERN THAN THE LIGHT HAZARD AREAS ON THE PLANS.
2. MAINTAIN THE INTEGRITY OF ALL FIRE RATED ASSEMBLIES AND ACOUSTICAL ASSEMBLIES.
3. CONTRACTOR SHALL COORDINATE SYSTEM DESIGN WITH ALL OTHER TRADES.
4. ALL PIPING SHALL OBSERVE PROPER PITCH. PROVIDE DRAINS FOR LOW POINTS.
5. PIPE HANGERS SHALL BE INSTALLED AS REQUIRED BY NFPA 13 FOR SUPPORTING SPRINKLER PIPING. NO OTHER PIPING OR DEVICES SHALL BE ATTACHED TO THE SPRINKLER HANGER SYSTEM UNLESS THE HANGER HAS BEEN DESIGNED TO CARRY THE ADDITIONAL LOAD.
6. THIS CONTRACT DOES NOT INCLUDE ANY MATERIAL OR DEVICE TO IMPROVE THE STRUCTURAL STRENGTH OF THE BUILDING TO ENABLE IT TO CARRY THE LOAD OF THE FIRE PROTECTION SYSTEM.
7. ALL ABOVE GROUND WET SPRINKLER PIPE THAT IS THREADED SHALL BE SCHEDULE 40 BLACK WITH BLACK CAST/MALLEABLE IRON FITTINGS WITH JOINTS PER NFPA 13. TEFLON TAPE SHALL BE ADDED TO ALL MALE THREADS OF PIPE AS A JOINING COMPOUND. CPVC PIPING IS NOT ACCEPTABLE.
8. ALL ABOVE GROUND WET SYSTEM SPRINKLER PIPE THAT IS WELDED OR ROLL-GROOVED SHALL BE SCHEDULE 10 BLACK WITH BLACK CAST/MALLEABLE IRON FITTINGS WITH JOINTS PER NFPA 13. CPVC PIPING IS NOT ACCEPTABLE.
9. INSTALL SPRINKLER HEADS CENTER OF TILE IN ACOUSTICAL CEILINGS. HEAD LOCATIONS SHALL BE GUIDED BY ARCHITECTURAL ELEMENTS FOR OTHER CEILING TYPES.
10. ALL WORK SHALL COMPLY WITH SIXTH EDITION (2017) OF FLORIDA BUILDING CODE, NFPA 13-2019, AND SIXTH EDITION (2017) FLORIDA FIRE PREVENTION CODE.

WATER BASED SPRINKLER SYSTEM REQUIREMENTS

1. THE PROJECT IS A MODIFICATION OF EXISTING FIRE SPRINKLER SYSTEM. NO CHANGE IN POINT OF SERVICE OF WATER SUPPLY WILL OCCUR.
2. THE BUILDING SHALL BE FULLY SPRINKLED IN ACCORDANCE WITH THE MOST RECENT EDITION OF NFPA 13 AND LOCAL CODES.
3. THERE IS NO CHANGE TO HAZARD CLASSIFICATION OF THE AFFECTED ROOMS.
4. THE MODIFICATION TO EXISTING SHALL BE HYDRAULICALLY CALCULATED IN ACCORDANCE WITH NFPA 13.
5. THE POINT OF SERVICE CONNECTION IS EXISTING, AND WILL NOT BE MODIFIED WITH THIS PROJECT.
6. NO NEW FLOW TEST IS REQUIRED FOR THIS MODIFICATION TO EXISTING SYSTEM.
7. THE EXISTING RISER WILL NOT BE MODIFIED WITH THIS PROJECT.
8. MICROBIAL INDUCED CORROSION IS NOT ANTICIPATED IN THIS PROJECT.
9. BACKFLOW PREVENTER IS EXISTING AND WILL NOT BE MODIFIED WITH THIS PROJECT.
10. REFER TO GENERAL NOTES FOR QUALITY AND PERFORMANCE SPECIFICATIONS OF ALL FIRE PROTECTION COMPONENTS.
11. NO FIRE PUMP IS REQUIRED.
12. NO ON SITE FIREWATER STORAGE TANK IS REQUIRED.

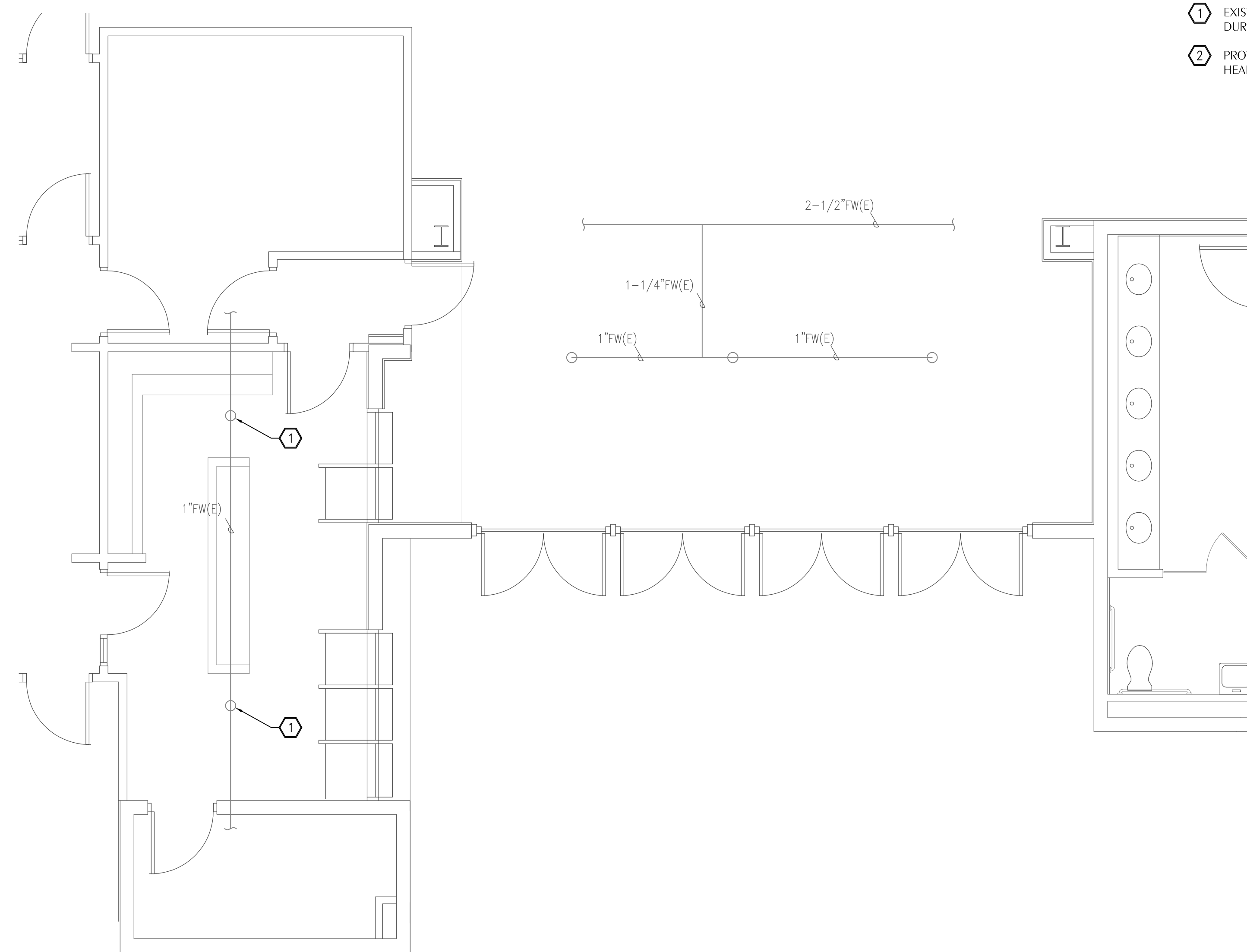

1 FIRE PROTECTION DEMOLITION PLAN
 SCALE: 1/4" = 1'-0"

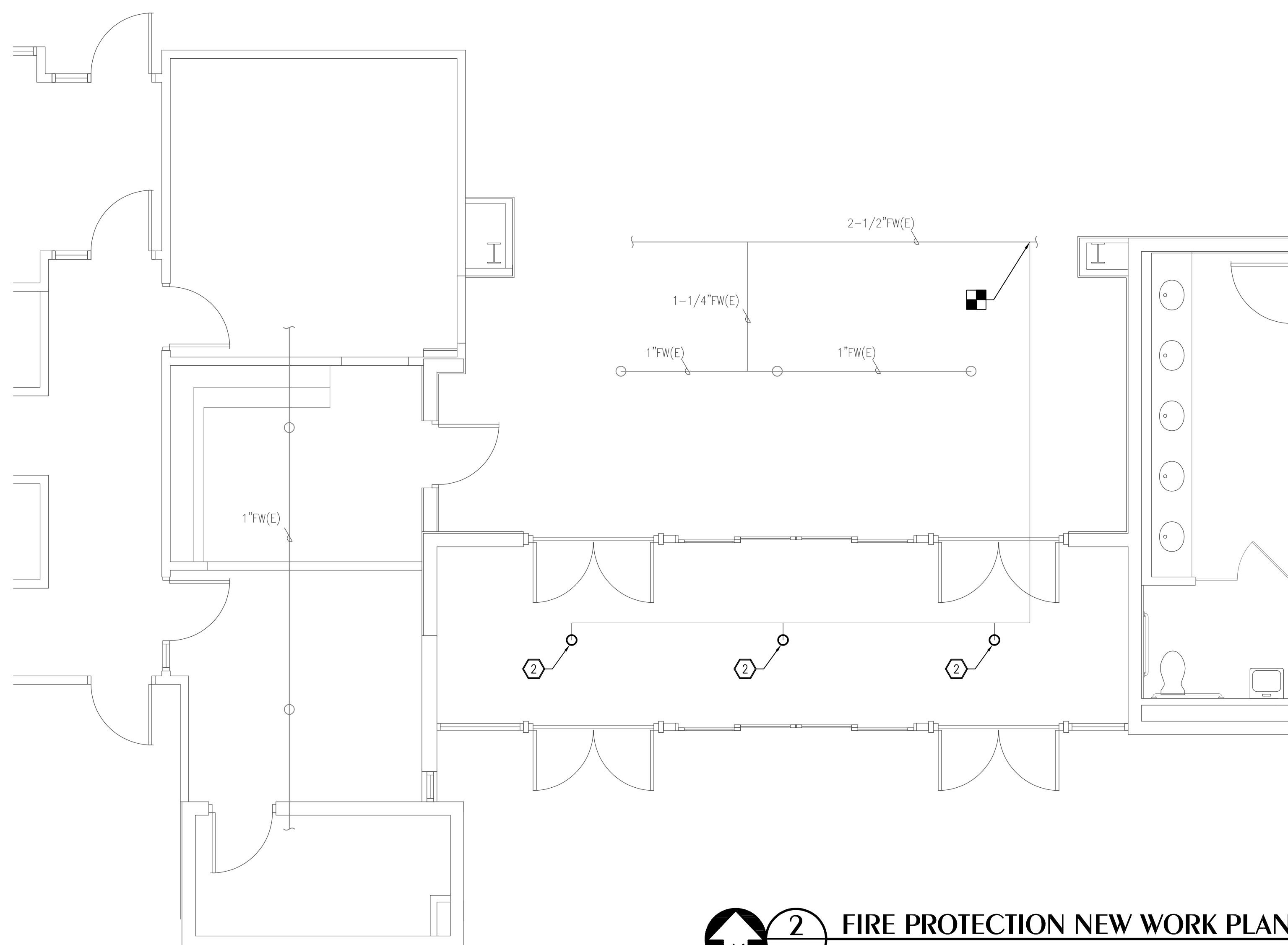

2 FIRE PROTECTION NEW WORK PLAN
 SCALE: 1/4" = 1'-0"

Watford Engineering, Inc.
 Mechanical Consulting
 4452 Clinton Street
 Marianna, FL 32446
 Florida CA Number: 27825
 Project Number: 2019-038

T: 850-526-3447
 F: 850-526-3448
 David N Watford, PE
 FL License Number: 58208

DAG ARCHITECTS
 DAG Architects, AAC000745
 1223 Airport Road Destin, Florida 32541
 850.837.8152 www.dagarchitects.com

CONSTRUCTION DOCUMENT

DESTIN FORT WALTON BEACH CONVENTION CENTER

EXTERIOR ACCESSIBILITY
 TASK ORDER No. 6b - C18-2638-TDD
 1250 MIRACLE STRIP PKWY SE
 FORT WALTON BEACH, FL 32548

No.	Description	Date

FIRE PROTECTION PLANS

Project number: 17057b
 Date: 06-12-2020
 PIC: DWV
 PM: KAJ

FP100

ALL REPORTS, PLANS, SPECIFICATIONS, COMPUTER FILES, FIELD DATA, NOTES AND OTHER DOCUMENTS AND INSTRUMENTS PREPARED BY THE CONSULTANT SHALL REMAIN THE PROPERTY OF THE CONSULTANT. THE CONSULTANT SHALL NOT BE RESPONSIBLE FOR THE ACCURACY OF ANY INFORMATION OBTAINED FROM ANY SOURCE OTHER THAN THAT PROVIDED BY THE CLIENT. THE CONSULTANT SHALL NOT BE RESPONSIBLE FOR THE ACCURACY OF ANY INFORMATION OBTAINED FROM ANY SOURCE OTHER THAN THAT PROVIDED BY THE CLIENT. THE CONSULTANT SHALL NOT BE RESPONSIBLE FOR THE ACCURACY OF ANY INFORMATION OBTAINED FROM ANY SOURCE OTHER THAN THAT PROVIDED BY THE CLIENT.

LEGEND

- AHU-1 EQUIPMENT TAG
1 M3 DETAIL TAG (*1" INDICATES IDENTIFICATION NUMBER, "M3" INDICATES THE SHEET NUMBER DRAWN ON)
1 SHEET NOTE
TYP TYPICAL
TEMP TEMPERATURE
FD FLOOR DRAIN
AFF ABOVE FINISHED FLOOR
DDC DIRECT DIGITAL CONTROL
VFM VENTURI FLOW METER
AI ANALOG INPUT
AO ANALOG OUTPUT
DI DIGITAL INPUT
DO DIGITAL OUTPUT
TAB TESTING, ADJUSTING AND BALANCING
NOM NOMINAL
E EXISTING
SUPPLY DUCT SECTION POSITIVE PRESSURE
RETURN OR EXHAUST DUCT NEGATIVE PRESSURE
AxB RECTANGULAR DUCT SIZE ("A" INDICATES SIDE SHOWN; "B" INDICATES SIDE NOT SHOWN)
EXTERNALLY INSULATED DUCTWORK
EXTERNALLY INSULATED ROUND FLEXIBLE DUCTWORK
DUCT ELBOW WITH TURNING VANES
RADIUS DUCT ELBOW
FLEXIBLE DUCT CONNECTION
MANUAL VOLUME BALANCING DAMPER
MOTORIZED DAMPER
FIRE DAMPER WITH ACCESS DOORS
TEE WITH TURNING VANES
TRANSITION
FLEX DUCT TAKE OFF WITH MVD SIZE EQUALS DIFFUSER NECK SIZE UNLESS NOTED OTHERWISE
BRANCH DUCT TAKEOFF WITH MVD
DUCT TO BE DEMOLISHED
EXISTING DUCTWORK TO REMAIN
SR-1 AIR DEVICE TAG. TOP LINE INDICATES TYPE OF DEVICE BOTTOM LINE INDICATES AIRFLOW IN CFM
100 POINT OF CONNECTION TO EXISTING

GENERAL SCOPE OF WORK

- 1. ALL WORK TO COMPLY WITH THE 2017 FLORIDA BUILDING CODE.
2. CONTRACTOR IS RESPONSIBLE FOR FIELD VERIFYING LOCATION OF ALL EQUIPMENT AND UTILITIES.
3. ALL WORK SHALL BE PERFORMED AND FINISHED IN A FIRST CLASS WORKMANLIKE MANNER. ALL WORK REQUIRED TO COMPLETE THE SCOPE OF WORK AND RETURN THE EQUIPMENT TO SERVICE SHALL BE INCLUDED IN THE CONTRACTOR'S BID.
4. WORK TO INCLUDE REMOVING AIR DEVICES IN ALL AREAS WHERE SHOWN ON DRAWINGS AND PROVIDING NEW AIR DEVICES AS SHOWN ON DRAWINGS.
5. CONTRACTOR TO ASSIST TEST AND BALANCE TO REBALANCE TERMINAL UNITS AND AIR DEVICES SHOWN IN SCHEDULE BELOW AND ON M200.

VARIABLE AIR VOLUME TERMINAL UNIT SCHEDULE

Table with columns: MARK, TOTAL CFM, COOL CFM MIN, HEATING CFM MAX, EAT (°F), LAT (°F), ELECTRIC HEATING COIL KW, VOLTS/PHASE, INLET SIZE (IN.).

DUCTWORK AND INSULATION GENERAL NOTES

- 1. ALL ROUND FLEXIBLE DUCT SHALL BE FLEXMASTER TYPE 8M OR ENGINEER APPROVED EQUAL. MAXIMUM LENGTH OF ANY FLEXIBLE DUCT RUNOUT SHALL BE 5'-0" WHERE LENGTH REQUIRED EXCEEDS 5'-0", INSTALL EXTERNALLY INSULATED ROUND SNAPLOCK DUCT FOR BALANCE OF DISTANCE TO SPIN-IN TAP AT MAIN DUCT TRUNK.
2. SEAL ALL DUCT PENETRATIONS OF WALLS AND FLOORS AIRTIGHT, REGARDLESS OF WHETHER WALLS AND FLOORS ARE FIRE RATED OR NOT.
3. UNLESS OTHERWISE INDICATED, ALL SUPPLY AIR DUCTWORK UPSTREAM OF TERMINAL UNITS SHALL BE OVAL OR ROUND, SMACNA STATIC PRESSURE CLASS 2" W.G., SEAL CLASS A, SPIRAL. DUCT SIZES INDICATED ARE INSIDE CLEAR DIMENSIONS.
4. ALL SUPPLY AIR DUCTWORK DOWNSTREAM OF TERMINAL UNITS (EXCEPT TAKEOFFS TO SUPPLY AIR DIFFUSERS) SHALL BE LOW PRESSURE RECTANGULAR, SMACNA STATIC PRESSURE CLASS 2" W.G., SEAL CLASS A, EXTERNALLY INSULATED. DUCT SIZES INDICATED ARE INSIDE CLEAR DIMENSIONS.
5. ALL RETURN AIR DUCTWORK SHALL BE LOW PRESSURE RECTANGULAR, SMACNA STATIC PRESSURE CLASS 2" W.G., SEAL CLASS A, EXTERNALLY INSULATED. DUCT SIZES INDICATED ARE INSIDE CLEAR DIMENSIONS. PROVIDE ACOUSTICAL DUCT LINER WHERE INDICATED.
6. ALL OUTSIDE AIR INTAKE DUCTWORK SHALL BE LOW PRESSURE RECTANGULAR, SMACNA STATIC PRESSURE CLASS 2" W.G., SEAL CLASS A, EXTERNALLY INSULATED. DUCT SIZES INDICATED ARE INSIDE CLEAR DIMENSIONS.
7. STANDARD EXHAUST AIR DUCTWORK SHALL BE LOW PRESSURE RECTANGULAR, SMACNA STATIC PRESSURE CLASS 1/2" W.G., SEAL CLASS A, INSULATION NOT REQUIRED.
8. AVOID ROUTING DUCTWORK AND TUS WITHIN 6" OF TOP OF LIGHT FIXTURES WHEREVER POSSIBLE. MAINTAIN CLEARANCE BETWEEN TUS AND DUCT INSULATION TO TOP OF LIGHTS. PROVIDE CLEARANCE ALL AROUND AIR TERMINAL UNITS AS REQUIRED FOR ROUTINE MAINTENANCE.
9. PROVIDE MVD'S AT ALL TAKEOFFS FROM MAIN DUCTS.

AIR DEVICE SCHEDULE

Table with columns: MARK, MAX AIRFLOW CFM, AIR DEVICE SIZE, DUCT CONNECTION SIZE, TITUS MODEL.

- NOTES:
1. MAX NC=20
2. PROVIDE 2x2 LAY IN PANEL FOR AIR DEVICES IN LAY IN CEILINGS.
3. PROVIDE BEVELED MOUNTING FRAME FOR CEILING DIFFUSERS IN HARD CEILINGS.
4. PROVIDE FLAT MOUNTING FRAME FOR GRILLES LOCATED IN HARD CEILINGS.

DESTIN FORT WALTON BEACH CONVENTION CENTER

EXTERIOR ACCESSIBILITY
TASK ORDER No. 66 - C18-2638-TDD
1250 MIRACLE STRIP PKWY SE
FORT WALTON BEACH, FL 32548

MECHANICAL LEGEND, SCHEDULE, NOTES, AND DETAILS

Table with columns: No., Description, Date.

Project number: 17057b
Date: 06-12-2020
PIC: DWV
PM: KAJ

1 DUCT HANGER DETAILS SCALE: NONE

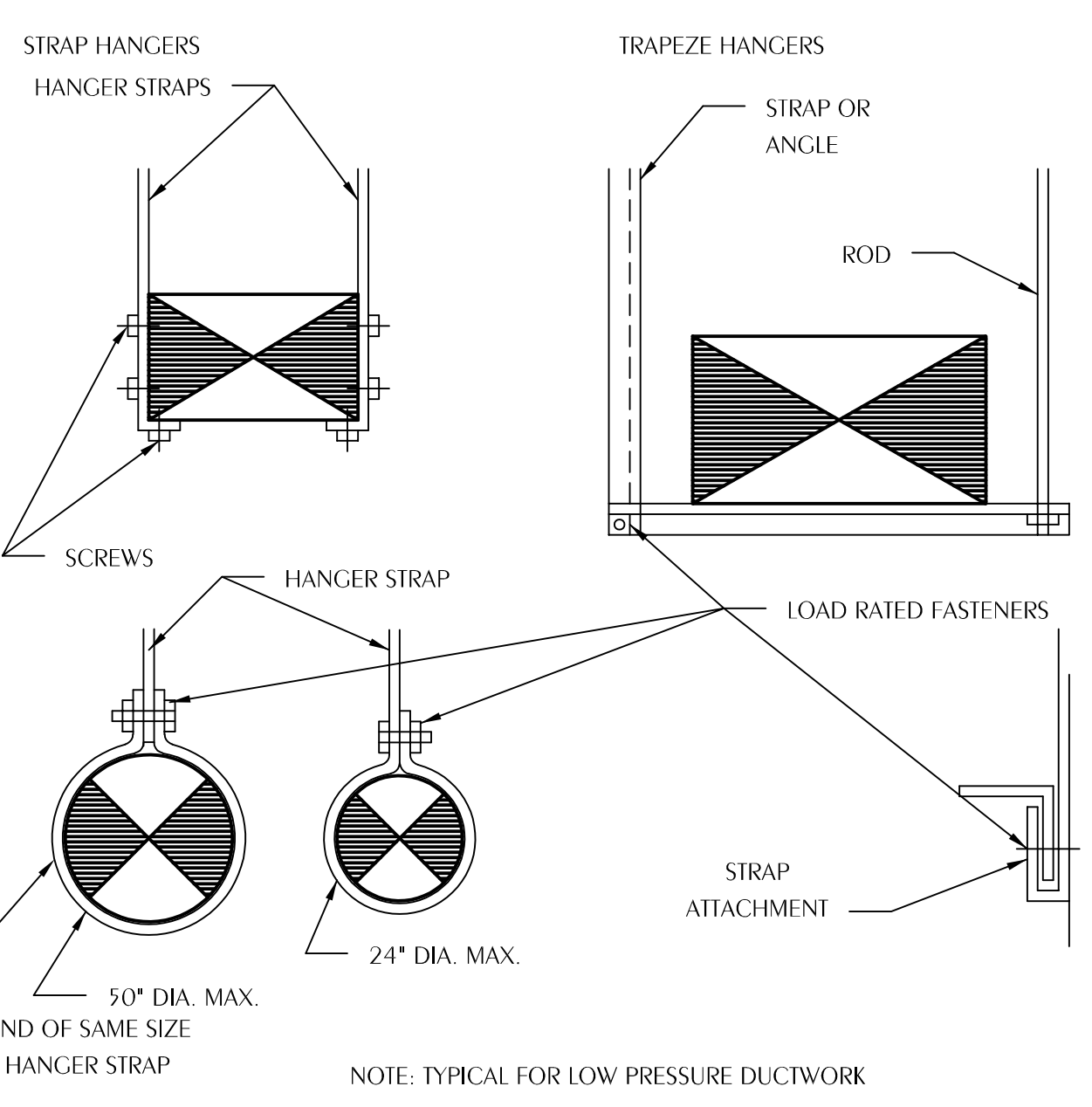

2 TYPICAL FLEX DUCT TAKEOFF DETAIL SCALE: NONE

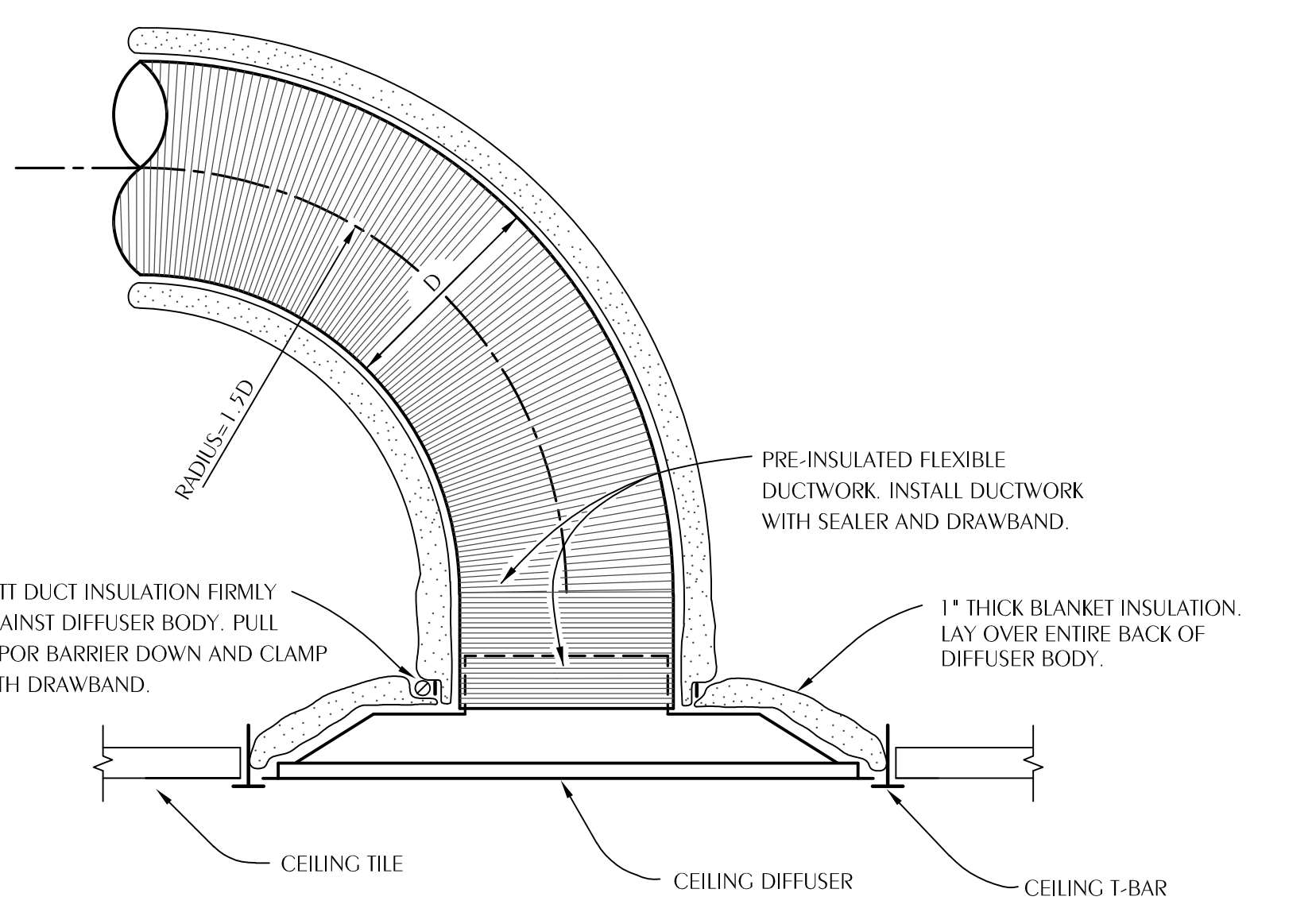

- NOTES:
FLEX DUCT SHALL BE NO LONGER THAN 5'-0". FLEXIBLE DUCT SHALL HAVE REINFORCED, METALIZED POLYESTER JACKET WITH NO FIBERGLASS EROSION IN THE AIRSTREAM AND AN ENCAPSULATED WIRE HELIX. FLEX DUCT SHALL HAVE OPERATING PRESSURE OF 6" W.G. AND NEGATIVE OPERATING PRESSURE OF 0.75" W.G. FLEX DUCT SHALL HAVE R-VALUE OF R-6 AND MEET REQUIREMENTS OF UL-181, 2017 FLORIDA ENERGY CODE, NFPA 90A AND NFPA 90B. AICO 36 OR APPROVED EQUAL.
PROVIDE 24x24 LAY IN PANEL FOR DIFFUSERS IN LAY IN CEILINGS.
PROVIDE BEVELED MOUNTING FRAME FOR DIFFUSERS IN HARD CEILINGS.

3 TYPICAL FLEX DUCT TAKEOFF DETAIL SCALE: NONE

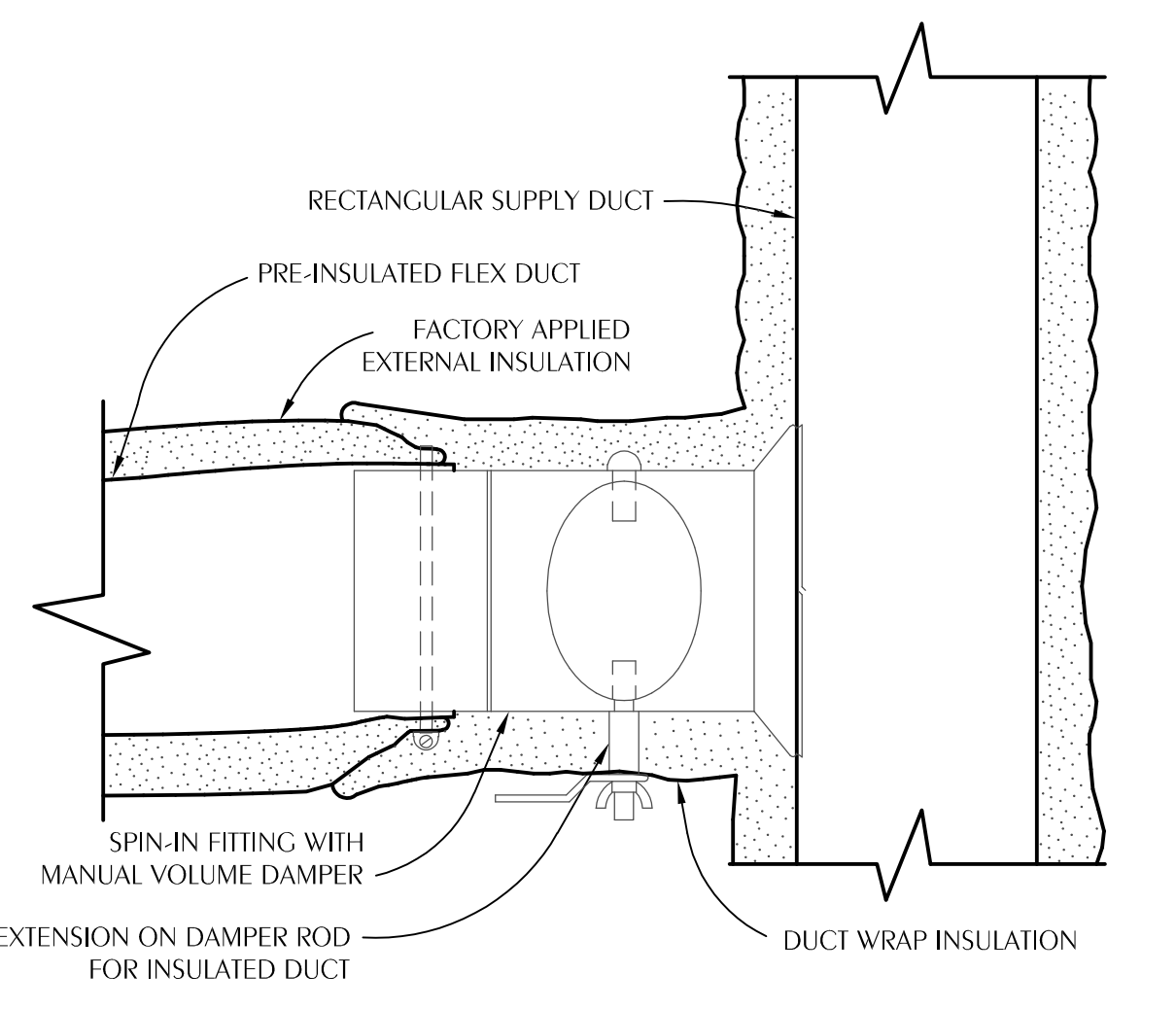

- NOTES:
CONNECT FLEXIBLE DUCT TO FITTING WITH DRAWBAND AND SEALER.
ROUND HARD DUCT RUNOUTS SHOULD START WITH SPIN-IN FITTINGS SIMILAR TO THIS DETAIL.
PROVIDE CABLE ACTIVATED DAMPER WITH ADJUSTMENT IN FACE OF CEILING DIFFUSER.
FLEXIBLE INSULATION SHALL BE 2" THICK, ASTM C553, TYPE 1, CLASS B-3 WITH 1 PCF DENSITY AND UL RATED ALUMINUM FOIL VAPOR BARRIER (FSK)

4 TRANSFER GRILLE DETAIL SCALE: NONE

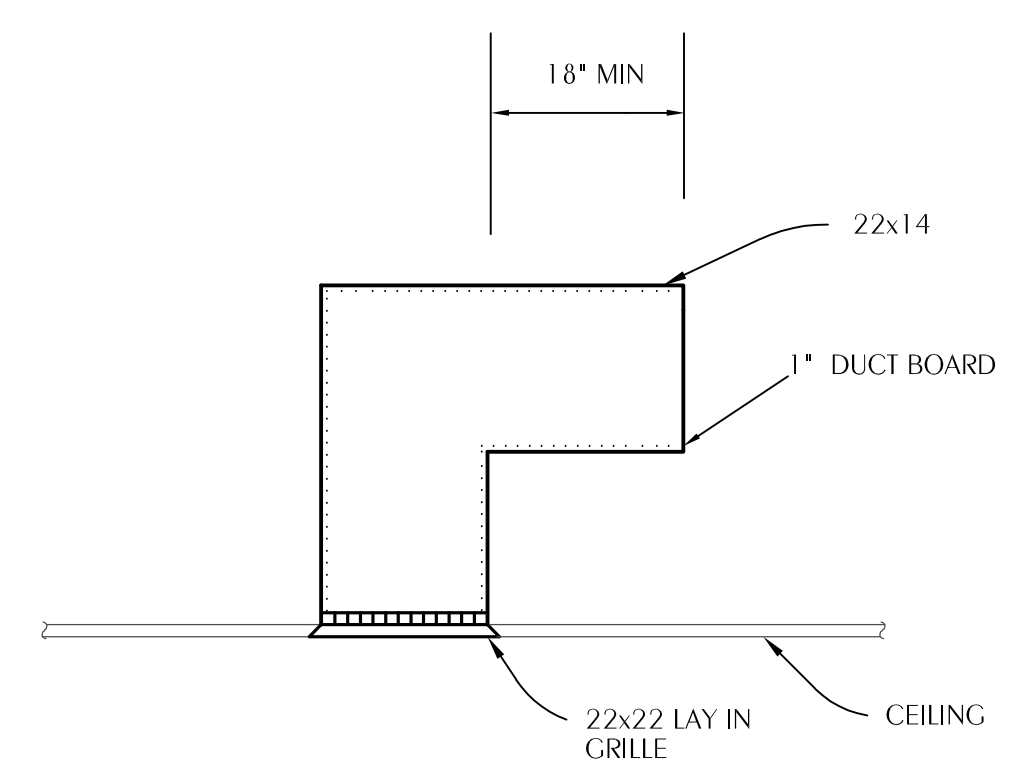

Watford Engineering, Inc. Mechanical Consulting
4452 Clinton Street
Marianna, FL 32446
Florida CA Number: 27825
Project Number: 2019-038
T: 850-526-3447
F: 850-526-3448
David N Watford, PE
FL License Number: 58208

ALL REPORTS, PLANS, SPECIFICATIONS, COMPUTER FILES, FIELD DATA, NOTES AND OTHER DOCUMENTS AND INSTRUMENTS PREPARED BY THE CONSULTANT SHALL REMAIN THE PROPERTY OF THE CONSULTANT. THE CONSULTANT SHALL NOT BE RESPONSIBLE FOR ANY REVISIONS, OMISSIONS, ERRORS, OR INADEQUACIES IN ANY INSTRUMENTS OR INFORMATION PROVIDED TO OTHERS. THE CONSULTANT SHALL NOT BE RESPONSIBLE FOR ANY REVISIONS, OMISSIONS, ERRORS, OR INADEQUACIES IN ANY INSTRUMENTS OR INFORMATION PROVIDED TO OTHERS. THE CONSULTANT SHALL NOT BE RESPONSIBLE FOR ANY REVISIONS, OMISSIONS, ERRORS, OR INADEQUACIES IN ANY INSTRUMENTS OR INFORMATION PROVIDED TO OTHERS.

ELECTRICAL GENERAL NOTES

- A. CONTRACTOR SHALL COORDINATE ALL WORK WITH OTHER TRADES PRIOR TO INSTALLATION. REFER TO MECHANICAL AND PLUMBING DRAWINGS FOR EXACT SIZE AND LOCATION OF EQUIPMENT WHICH IS FURNISHED BY OTHERS AND CONNECTED BY ELECTRICAL.
B. RECEPTACLES, SWITCHES AND COVERPLATES COLOR SHALL BE SELECTED BY THE ARCHITECT FROM STANDARD COLORS.
C. VERIFY ALL DOOR SWINGS WITH ARCHITECTURAL DRAWINGS PRIOR TO ROUGHING-IN WALL FOR SWITCHES.
D. LOCATION OF LIGHTING FIXTURES, DISCONNECT SWITCHES, ETC. FOR MECHANICAL EQUIPMENT/ROOM SHALL BE COORDINATED WITH FINAL MECHANICAL EQUIPMENT LOCATION TO PROVIDE NATIONAL ELECTRIC CODE REQUIRED ACCESS SPACE.
E. FINAL CONNECTION TO ALL MOTORS SHALL BE WITH FLEXIBLE CONDUIT CONNECTION.
F. ALL EXIT AND EMERGENCY FIXTURES SHALL BE CONNECTED TO LIGHT CIRCUIT AHEAD OF LOCAL SWITCH.
G. ALL PANELBOARDS, BACKBOARDS, TERMINAL CABINETS, ETC SHALL HAVE CUSTOM ENGRAVED MICARTA NAMEPLATE MECHANICALLY AFFIXED IDENTIFYING SYSTEM.
H. PROVIDE GREEN GROUND CONDUCTOR IN ALL CIRCUITS - SIZE PER N.E.C.
I. ALL EXPOSED CONDUITS, BOXES, STRAPS AND HANGERS IN THE CONTRACT AREA WHETHER NEW OR EXISTING THAT ARE PART OF THE ELECTRICAL SYSTEM SHALL BE PAINTED TO MATCH ADJACENT FINISH.
J. PROVIDE CONCRETE MARKER AT END OF ALL CONDUITS STUBBED OUT OF BUILDING FOR FUTURE USE. MARKER SHALL BE 6" DIA X 18" HIGH WITH 2" ABOVE FINISHED GRADE. INSCRIBE IN TOP OF MARKER "E" FOR ELECTRICAL, "T" FOR TELEPHONE, "V" FOR TV CABLE, "F" FOR FIRE ALARM, AND "IC" FOR INTERCOM.
K. GENERAL CONTRACTOR SHALL FIELD-VERIFY ALL EXISTING CONDITIONS PRIOR TO BEGINNING ANY WORK, AND SHALL IMMEDIATELY NOTIFY THE ARCHITECT OF ANY DISCREPANCIES. FAILURE TO DO SO INDICATES THAT THE CONTRACTOR ACCEPTS THE CONDITIONS AS THEY EXIST, AND SHALL PERFORM THE WORK REQUIRED AS SHOWN AND SPECIFIED.
L. THE ELECTRICAL CONTRACTOR SHALL OBTAIN AND REVIEW THE MECHANICAL AND SPECIAL EQUIPMENT SUBMITTALS PRIOR TO SUBMITTING THE ELECTRICAL SUBMITTALS. ANY ELECTRICAL EQUIPMENT, CONDUIT, AND WIRE SIZE CHANGES RESULTING FROM THIS REVIEW SHALL ALSO BE SUBMITTED FOR APPROVAL.
M. FIRE ALARM LOW VOLTAGE SOURCE AND BATTERY STANDBY SHALL ENERGIZE ALL ITEMS IN FIRE ALARM SYSTEM THAT REQUIRE POWER.
N. FINAL CONNECTION TO ALL DRY TYPE TRANSFORMERS SHALL BE WITH FLEXIBLE CONDUIT CONNECTION.
O. THE ELECTRICAL CONTRACTOR SHALL PROVIDE FAULT CURRENT CALCULATIONS FOR THE SERVICE EQUIPMENT AND SHALL MARK THE EQUIPMENT WITH THE AVAILABLE FAULT CURRENT AND DATE OF THE CALCULATION PER NEC 110.24. REFER TO TYPICAL SERVICE EQUIPMENT FAULT CURRENT LABEL DETAIL.
P. THE ELECTRICAL CONTRACTOR SHALL PROVIDE ARC FAULT LABELS PER NFPA 70E ARTICLE 110.16 FOR NEW EQUIPMENT. THE OWNER SHALL PROVIDE AVAILABLE CALCULATION DATA FOR THE EXISTING EQUIPMENT IN THE ELECTRICAL SYSTEM. REFER TO TYPICAL ARC FLASH HAZARD LABEL DETAIL.
Q. PROVIDE NEUTRAL AT ALL LINE VOLTAGE SWITCH LOCATIONS PER N.E.C. 404.2(C).
R. COMPLY 'LSI' TRIP UNITS FOR ALL BREAKERS GREATER THAN OR EQUAL TO 200A.
S. COMPLY WITH ALL LOCAL CODE, LAWS, AND ORDINANCES APPLICABLE TO ELECTRICAL WORK, THE STATE BUILDING CODE AND THE NATIONAL ELECTRIC CODE. OBTAIN ALL PERMITS REQUIRED BY LOCAL ORDINANCES.
T. OBTAIN ARCHITECTS APPROVAL OF ALL LIGHT FIXTURES, SWITCHES, RECEPTACLES, PANELBOARDS, ETC. PRIOR TO PURCHASING.
U. THE ELECTRICAL WORK SHALL BE INSTALLED IN A NEAT AND WORKMANLIKE MANNER. ALL NOT SO INSTALLED SHALL BE REMOVED AND REPLACED AT NO COST TO THE OWNER.
V. ALL WORK SHALL BE INSTALLED IN CONCEALED TYPE CONSTRUCTION. UNDERGROUND CONDUITS UP TO FIRST BOX IN CONCEALED CONSTRUCTION MAY BE SCH.40 PVC. EXTERIOR EXPOSED WORK SHALL BE I.M.C. BRANCH CIRCUIT CONDUIT RUN IN OPEN SPACES ABOVE CEILING OR IN WALLS MAY BE THINWALL (E.M.T.) CONDUIT 1/2" MIN. SIZE.
W. ALL CONDUCTORS LESS THAN 100A. SHALL BE COPPER #12 & #10 SOLID, #8 AND LARGER STRANDED, #6 AND SMALLER TO BE TYPE THW, 600 VOLT INSULATION AND TYPE THW OR THHN FOR #4 AND LARGER. ALUM. CONDUCTORS MAY BE USED FOR 100A. AND LARGER ONLY WHERE USED WITH COMPRESSION TERMINATIONS.
X. PROVIDE GROUNDING PER NATIONAL ELECTRIC CODE.
Y. THE CONTRACTOR SHALL LEAVE THE ENTIRE ELECTRICAL SYSTEM INSTALLED IN PROPER WORKING ORDER, AND SHALL REPLACE WITHOUT ADDITIONAL COST, ALL WORK OR MATERIAL WHICH MAY DEVELOP DEFECTS, (ORDINARY WEAR AND TEAR OR DAMAGE RESULTING FROM IMPROPER HANDLING EXCEPTED) WITHIN A PERIOD OF ONE (1) YEAR FROM THE DATE OF FINAL ACCEPTANCE BY THE OWNER.

ELECTRICAL LEGEND

- A-1 ADJACENT TO ARROW INDICATES HOMERUN OF CIRCUIT NO. 1 TO PANEL A; "B" INDICATES FIXTURE TYPE; MARKS ACROSS RACEWAY RUN INDICATES THE NUMBER OF NO. 12 CONDUCTORS; UNLESS NOTED OTHERWISE NO MARKS INDICATES TWO NO. 12 CONDUCTORS AND ONE NO. 12 GREEN GROUND CONDUCTOR IN 1/2" CONDUIT (2#12 & 1#12 GND-1/2"C)
CEILING FIXTURE
WALL BRACKET FIXTURE
POLE MOUNTED FIXTURE
2' X 2' FIXTURE; CEILING MOUNTED; ARROW INDICATES LENS DIRECTION
EXIT SIGN; CEILING MOUNTED; ARROWS AS NOTED; SHADED SECTION INDICATES LIGHTED FACE OF EXIT SIGN
JUNCTION BOX; MOUNTED ABOVE CEILING
DUPLEX RECEPTACLE; 125V; 20A; 3 POLE GND; MT 18" AFF TO C/L UNLESS NOTED OTHERWISE; NEMA 5-20R; HUBBELL SERIES HBL5352
WALL SWITCH; 120/277V; 20A; 1 POLE; A.C. ONLY; MT 48" AFF TO C/L; HUBBELL SERIES HBL1221
LOW VOLTAGE WALL SWITCH; CONNECT TO LOCAL POWER PACK/ROOM CONTROL; MT 48" AFF TO C/L; REFER TO SPECS; SEE LIGHTING CONTROL DETAILS LETTER "X" INDICATES BUTTON COUNT; REFER TO LOW VOLTAGE SWITCH SCHEDULE FOR SPECIFIC INFORMATION.
VACANCY SENSOR POWER PACK; MOUNT ABOVE CEILING
LOW VOLTAGE VACANCY SENSOR; 360° DUAL-TECHNOLOGY TYPE; CEILING MOUNTED; UNLESS OTHERWISE NOTED; REFER TO LIGHTING CONTROLS DETAILS
MOTOR; FURNISHED BY OTHERS
NON-FUSED DISCONNECT SWITCH; AMP SIZE AS NOTED
RACEWAY INSTALLED CONCEALED IN WALLS AND/OR ABOVE CEILING
DATA SYSTEM WALL OUTLET WITH SIX(6) RJ-45 JACK AND COVERPLATE; MT 18" AFF TO C/L UNLESS NOTED OTHERWISE - INSTALL 3/4"C WITH PULLRIBBON UP INTO CEILING SPACE.
FIRE ALARM SYSTEM MANUAL PULL STATION; MT 48" AFF TO C/L
FIRE ALARM SYSTEM STROBE; MT 80" AFF TO BOTTOM, '110' INDICATES CANDELA RATING, NO NUMBER INDICATES 75 CANDELA MINIMUM

ABBREVIATIONS

- AFF - ABOVE FINISHED FLOOR
AFG - ABOVE FINISHED GRADE
C - CONDUIT
C/L - CENTERLINE
EC - ELECTRICAL CONTRACTOR
GND - GROUND CONDUCTOR
GFI - GROUND FAULT PROTECTION
LTC - LIGHTING
LTS - LIGHTS
REC - RECEPTACLE
UNO - UNLESS NOTED OTHERWISE

SPECIAL DEMOLITION NOTE
THE LOCATIONS OF ALL ELECTRICAL EQUIPMENT INDICATED (FIXTURES & DEVICES) MAY VARY FROM DRAWING. EXISTING CONDITIONS AND DEMOLITION WORK WAS DETERMINED BY SITE OBSERVATION AND REVIEW OF EXISTING DOCUMENTS WITHOUT THE BENEFIT OF DESTRUCTIVE INVESTIGATION. VERIFY ACTUAL LOCATIONS, TYPES, AND QUANTITIES OF EQUIPMENT AND APPLY DEMOLITION NOTES AS APPROPRIATE FOR THE EQUIPMENT AND ROOM OR AREA.

TOXIC MATERIAL DEMOLITION NOTE

IF THE CONTRACTOR SUSPECTS TOXIC MATERIALS SUCH AS ASBESTOS AND/OR LEAD-BASED PAINT WILL BE AFFECTED AS PART OF THIS PROJECT THESE SHALL BE IDENTIFIED BEFORE CONSTRUCTION START. IF FEASIBLE, OTHERS WILL TEST FOR AND REMOVE THESE MATERIALS PRIOR TO CONSTRUCTION START. IF THESE MATERIALS MUST REMAIN IN PLACE THE CONTRACTOR WILL MINIMIZE THE DISTURBANCE OF SUCH MATERIALS LEAVING THEM ENCAPSULATED. WHERE SUCH MATERIALS CANNOT BE LEFT ENCAPSULATED THE CONTRACTOR SHALL INCLUDE TESTING OF THESE SPECIFIED AREAS AS PART OF THE PROJECT SCOPE. REMOVAL OF THESE MATERIALS IS NOT TO BE INCLUDED IN THE PROJECT SCOPE.

ELECTRICAL DEMOLITION NOTES

- 1. PLANNED INTERRUPTIONS OF UTILITY SERVICE TO ANY FACILITY OR AREAS WITHIN ANY FACILITY AFFECTED BY THIS CONTRACT, SHALL BE CAREFULLY PLANNED AND COORDINATED WITH THE FACILITY PERSONNEL IN ADVANCE OF THE REQUESTED INTERRUPTION. THE CONTRACTOR SHALL NOT INTERRUPT SERVICES UNTIL SPECIFIED APPROVAL HAS BEEN GRANTED. THE REQUEST SHALL INDICATE SERVICES AND AREAS TO BE AFFECTED, DATE AND TIME OF INTERRUPTION AND DURATION OF OUTAGE. REQUEST FOR INTERRUPTION OF SERVICE WILL NOT BE APPROVED UNTIL ALL EQUIPMENT AND MATERIAL REQUIRED FOR THE COMPLETION OF THAT PARTICULAR PHASE OF WORK ARE ON THE JOB SITE.
2. ALL DEMOLITION WORK REQUIRED SHALL BE PERFORMED WITH CARE SO AS NOT TO INTERRUPT OTHER EXISTING SERVICES (WATER, GAS, ELECTRICAL, SEWER, SPRINKLERS, ETC.). IF ACCIDENTAL UTILITY INTERRUPTION, DAMAGE, ETC., RESULTS FROM WORK PERFORMED BY THE CONTRACTOR, THE AFFECTED UTILITY OR SERVICE SHALL BE RETURNED TO ITS ORIGINAL CONDITION WITHOUT DELAY, BY AND AT THE EXPENSE OF THE CONTRACTOR, USING SKILLED WORKMEN OF THE TRADE INVOLVED.
3. REMOVE ALL OUTLETS, PULL BOXES, JUNCTION BOXES, ETC., AS REQUIRED TO COMPLETELY REMOVE THE ELECTRICAL ITEMS SHOWN FOR DEMOLITION UNLESS NOTED TO REMAIN. DISCONNECT AND REMOVE ALL ELECTRICAL PROVISIONS TO EQUIPMENT BEING REMOVED.
4. REMOVE ALL WIRING, CONDUIT, RACEWAYS, OUTLET BOXES, SUPPORTING APPARATUS ETC., AS REQUIRED.
5. SYMBOLS SHOWN ARE TYPICAL AND LOCATIONS ARE APPROXIMATE AND ARE NOT INTENDED TO LIMIT THE AMOUNT OF DEMOLITION. COORDINATE WITH EXISTING CONDITIONS AND THESE NOTES AND REMOVE ALL APPLICABLE SYSTEMS AND COMPONENTS CONFLICTING WITH FINISHED DESIGN INTENT.
6. EXISTING BRANCH WIRING SHOWN IS DIAGRAMMATICAL ONLY AND IS BASED UPON EXISTING AS-BUILT DRAWINGS AND SURVEYS. COORDINATE WITH ACTUAL EXISTING CONDITIONS FOR NUMBER OF CONDUCTORS PER CONDUIT AND EXACT LOCATIONS OF CONDUIT RUNS AND EQUIPMENT.
7. ALL FEEDERS, SYSTEMS, CONTROL WIRING, MISCELLANEOUS AUXILIARY SYSTEMS, ETC., PASSING THROUGH THE AREA OF WORK SHALL BE MAINTAINED AT ALL TIMES, REMAIN IN SERVICE, CONTINUOUS AND UNINTERRUPTED. ANY DAMAGE, DISRUPTION OR DISCONNECTION SHALL BE IMMEDIATELY REPAIRED, REPLACED AND/OR REROUTED AS REQUIRED TO MAINTAIN CONTINUITY OF SYSTEMS. ANY EXISTING SERVICE OR OPERATING SYSTEM WHICH MUST BE INTERRUPTED SHALL BE SUPPLIED WITH A TEMPORARY SERVICE FOR CONTINUATION OF THE NORMAL OPERATIONS OF THE FACILITY.
8. ANY EQUIPMENT THAT REQUIRES REMOVAL FROM EXISTING LOCATION FOR RE-USE OR TO BE RETURNED TO OWNER SHALL BE INSPECTED AND TESTED TO CONFIRM EQUIPMENT OPERATES AS INTENDED. OWNER SHALL BE NOTIFIED OF ANY EQUIPMENT THAT DOES NOT OPERATE AS INTENDED BEFORE REMOVAL.
9. CONCEALED CONDUIT THAT CANNOT BE REMOVED DUE TO INACCESSIBILITY MAY BE ABANDONED. CONDUCTORS SHALL BE REMOVED AND CONDUIT CUT FLUSH WITH SURFACE.
10. OUTLET BOXES THAT CANNOT BE REMOVED DUE TO FLUSH MOUNTING IN PARTITIONS SHALL BE FILLED WITH GROUT, PATCHED AND FINISHED FLUSH TO MATCH EXISTING WALL CONDITIONS.
11. IN GENERAL, THE WORK SHALL INCLUDE BUT NOT BE LIMITED TO THE FOLLOWING:
a. PROVIDE ALL DEMOLITION AS REQUIRED OF EXISTING SYSTEMS REMOVING ALL ITEMS THAT CONFLICT WITH FINISHED DESIGN INTENT AS INDICATED ABOVE.
b. MODIFY, REPLACE, REPAIR, REVISE ETC., EXISTING SYSTEMS AND/OR EQUIPMENT.
c. EXTEND EXISTING SYSTEMS AS REQUIRED TO FUNCTION AS SPECIFIED AND IN ACCORDANCE WITH SYSTEM REQUIREMENTS.
d. NEW SYSTEM COMPONENTS SHALL MATCH EXISTING SYSTEMS PROVISIONS AND BE COMPLETELY COMPATIBLE AND IN ACCORDANCE WITH THE MANUFACTURER'S REQUIREMENTS. WHEN REQUIRED, APPROVAL FROM A SYSTEM MANUFACTURER SHALL BE OBTAINED BY THE CONTRACTOR PRIOR TO INSTALLING ANY NEW EQUIPMENT OR DEVICES TO AN EXISTING SYSTEM.
e. ALL EQUIPMENT, DEVICES, OUTLETS, COMPONENTS, ETC., TO BE REUSED SHALL BE CLEANED, REPAIRED AND PLACED IN OPERATING CONDITION. LUMINARIES NOTED TO BE REUSED SHALL BE CLEANED, REPAIRED, PROVIDED WITH NEW LAMPS AND PLACED IN OPERATING CONDITION.
f. EXISTING OUTLET BOXES MAY BE USED AS NOTED IF OF THE PROPER CONFIGURATION AND SIZE REQUIRED. MODIFICATIONS SHALL BE MADE WHEN REQUIRED SUCH AS PROVIDING EXTENSION RINGS, LOCKNUTS, BUSHINGS, ETC.
g. EXISTING PANELBOARDS SHALL BE UTILIZED TO THE EXTENT SHOWN ON THE DRAWINGS AND MODIFIED AS REQUIRED TO FACILITATE THE NEW REQUIREMENTS AS INDICATED HEREIN OR SHOWN ON THE DRAWINGS. NEW CIRCUIT BREAKERS SHALL BE OF THE SAME MANUFACTURER, FRAME SIZE, SHORT CIRCUIT RATING AND TYPE AS EXISTING. WHERE APPLICABLE, THE CONTRACTOR SHALL BE REQUIRED TO FURNISH AND INSTALL ADDITIONAL MOUNTING HARDWARE AS REQUIRED BY THE MANUFACTURER.
h. WHEN EXISTING DEVICES, SWITCHES, EQUIPMENT ETC., ARE NOTED TO BE REMOVED AND THE CIRCUIT(S) SERVING SUCH ITEMS SERVES OTHER ITEMS OR DEVICES WHICH ARE TO BE MAINTAINED, THE CONTRACTOR SHALL REROUTE, EXTEND, MODIFY, ETC., EXISTING CIRCUITS AS REQUIRED TO MAINTAIN COMPLETE AND OPERATING SYSTEMS.



CONSTRUCTION DOCUMENT

DESTIN FORT WALTON BEACH CONVENTION CENTER

EXTERIOR ACCESSIBILITY
TASK ORDER No. 66 - C18-2638-TDD
1250 MIRACLE STRIP PKWY SE
FORT WALTON BEACH, FL 32548

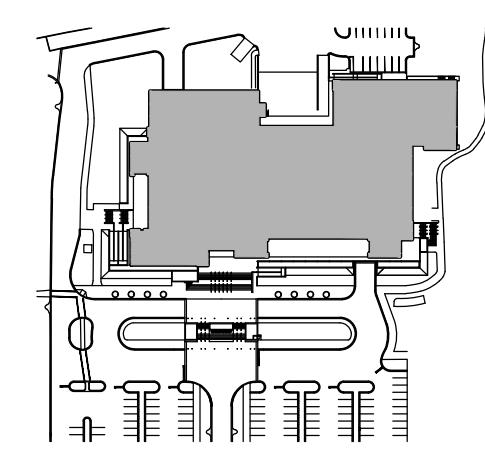
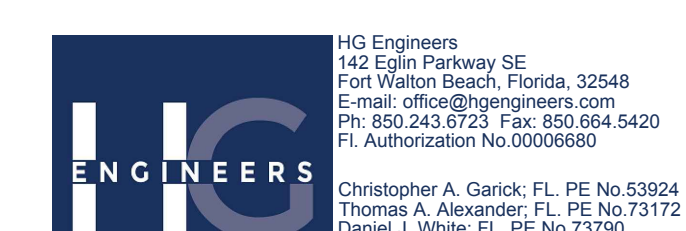

Table with 3 columns: No., Description, Date. Contains empty rows for project notes.

LEGEND AND NOTES

Project number: 17057b
Date: 06-12-2020
PIC
PM

E001



ALL REPORTS, PLANS, SPECIFICATIONS, COMPUTER FILES, FIELD DATA, NOTES AND OTHER DOCUMENTS AND INSTRUMENTS PREPARED BY THE CONSULTANT ARE THE PROPERTY OF THE CONSULTANT. THE CONSULTANT SHALL NOT BE RESPONSIBLE FOR THE ACCURACY OF THE INFORMATION PROVIDED TO OTHERS. THE CONSULTANT SHALL NOT BE RESPONSIBLE FOR THE ACCURACY OF THE INFORMATION PROVIDED TO OTHERS. THE CONSULTANT SHALL NOT BE RESPONSIBLE FOR THE ACCURACY OF THE INFORMATION PROVIDED TO OTHERS.



DAG ARCHITECTS
DAG Architects, AAC000745
1223 Airport Road Destin, Florida 32541
850.837.8152 www.dagarchitects.com

CONSTRUCTION DOCUMENT

DESTIN FORT WALTON BEACH CONVENTION CENTER

EXTERIOR ACCESSIBILITY
TASK ORDER No. 6b - C18-2638-TDD
1250 MIRACLE STRIP PKWY SE
FORT WALTON BEACH, FL 32548

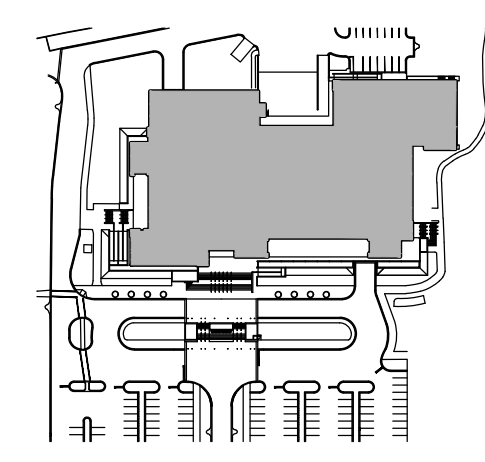

No.	Description	Date

SITE PLAN - ELECTRICAL - DEMOLITION

Project number: 17057b
Date: 06-12-2020

PHC
PM
1986
Job No.

ED101

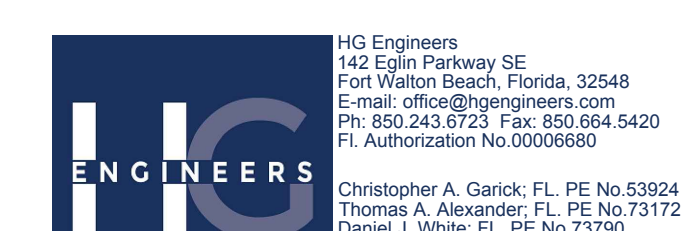

IHC ENGINEERS
IHC Engineers
145 Eglin Parkway SE
Fort Walton Beach, Florida, 32548
E-mail: office@ihcengineers.com
Ph: 850.243.6723 Fax: 850.964.5420
FL Authorization No. 00066600
Christopher A. Garick, FL PE No. 53924
Thomas A. Alexander, FL PE No. 73172
Daniel J. White, FL PE No. 73796

SITE PLAN - ELECTRICAL - DEMOLITION

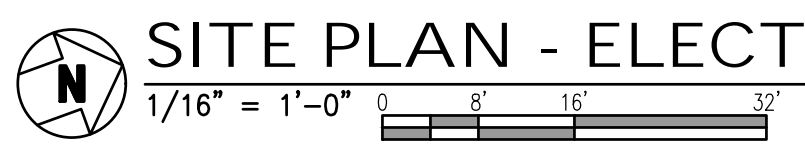

- NOTES**
- ① REMOVE BOLLARD. REMOVE EXISTING CONDUCTORS AND CAP EXISTING CONDUIT. ADD PAVERS TO MATCH EXISTING.
 - ② REMOVE FIXTURE, POLE AND POLE BASE. REMOVE EXISTING CONDUCTORS AND CAP EXISTING CONDUIT.
 - ③ REMOVE EXISTING FOUNTAIN CONDUCTORS AND CAP EXISTING CONDUIT.
 - ④ REMOVE METER, PANEL AND EXISTING CONDUCTORS BACK TO EXISTING TRANSFORMER. REPAIR BACKBOARD AS REQUIRED

REFER TO E301 FOR DEMOLITION IN THIS AREA

CONSERVATION OF INSTRUMENTS OF SERVICE
ALL REPORTS, PLANS, SPECIFICATIONS, COMPUTER FILES, FIELD DATA, NOTES AND OTHER DOCUMENTS AND INSTRUMENTS PREPARED BY THE CONSULTANT SHALL REMAIN THE PROPERTY OF THE CONSULTANT. THE CONSULTANT SHALL RETAIN A COMPLETE SET OF INSTRUMENTS OF SERVICE. IT IS THE RESPONSIBILITY OF THE CONSULTANT TO PROTECT AND MAINTAIN ALL INSTRUMENTS OF SERVICE. INSTRUMENTS OF SERVICE WHICH ARE LOST OR DESTROYED SHALL BE REPLACED AT THE CONSULTANT'S EXPENSE. INSTRUMENTS OF SERVICE WHICH ARE LOST OR DESTROYED SHALL BE REPLACED AT THE CONSULTANT'S EXPENSE.

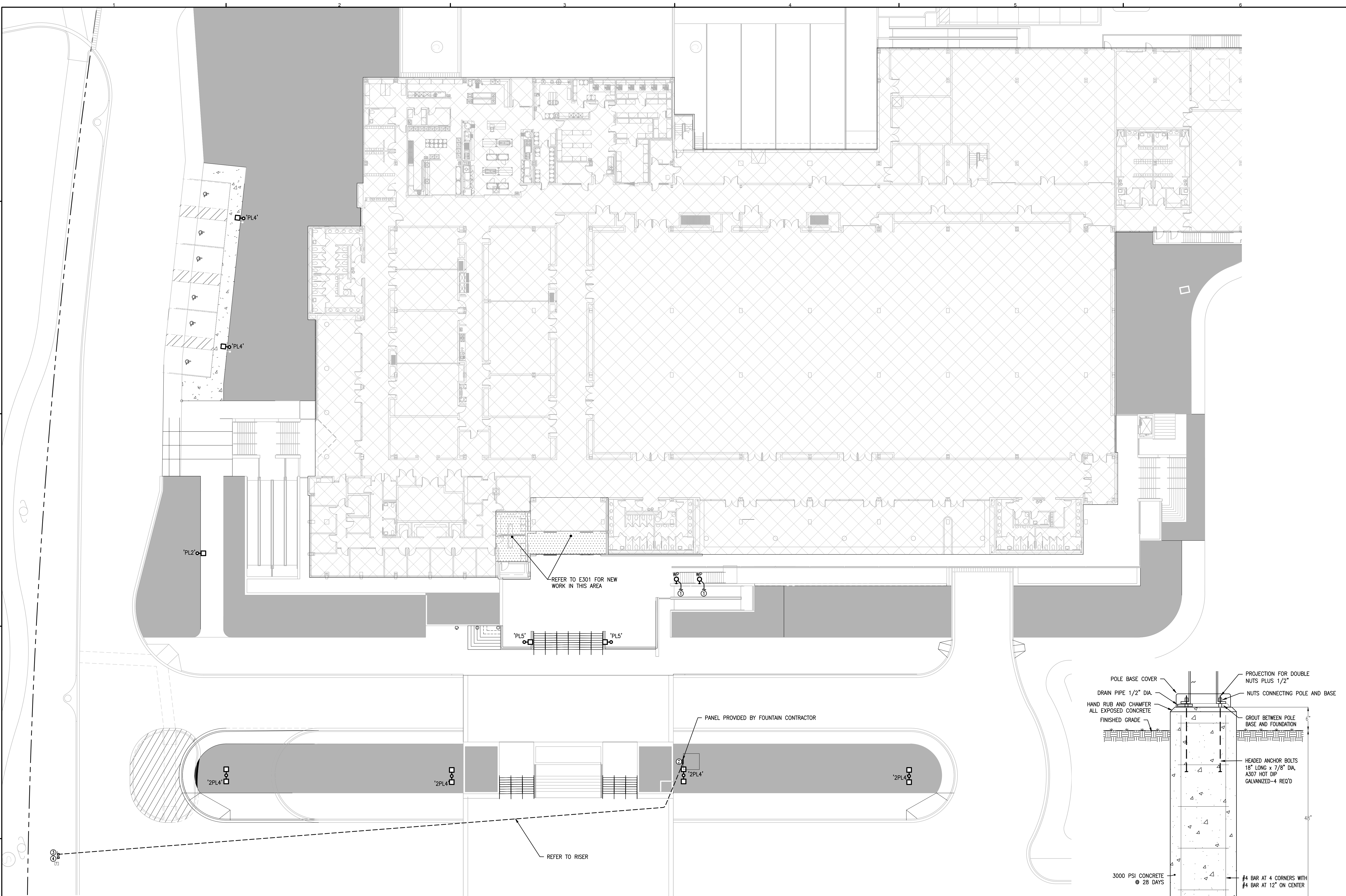

- NOTES**
- 1 CONNECT NEW 'WP' FIXTURE TO PATH LIGHT ON OPPOSITE WALL.
 - 2 COORDINATE WITH FOUNTAIN INSTALLER FOR TOTAL CONNECTED LOAD AND LOCATION.
 - 3 INSTALL NEW NEMA3R 200 AMP, 240/120V 1Ø CIRCUIT BREAKER.
 - 4 INSTALL NEW METER TO MATCH PANEL CURRENT RATING.

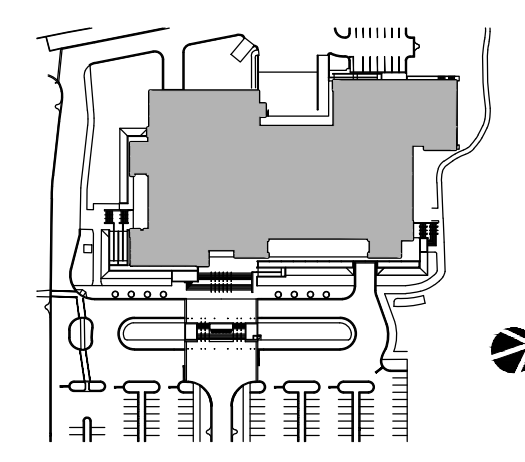
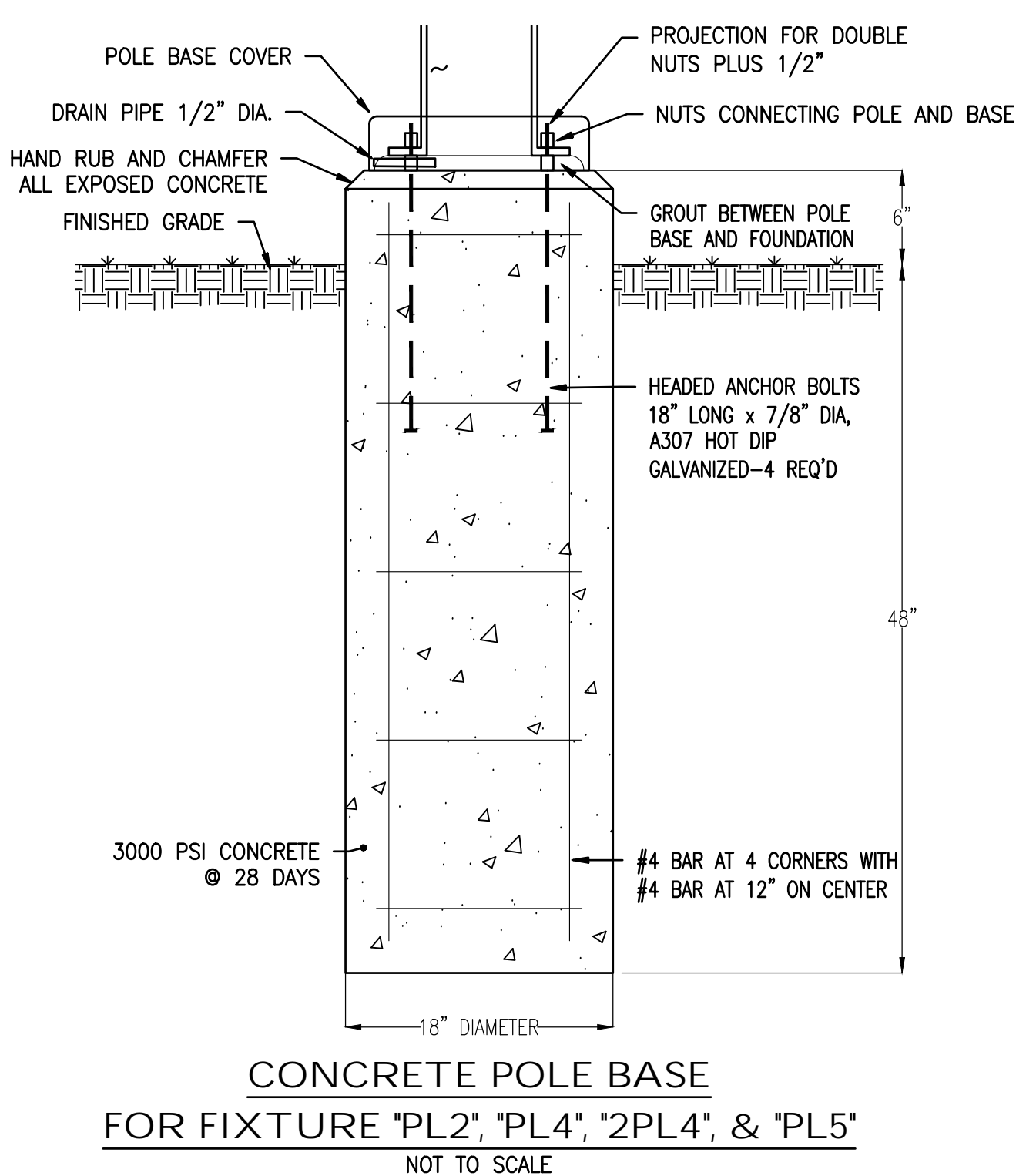

No.	Description	Date

CONSERVATION OF INSTRUMENTS OF SERVICE
 ALL REPORTS, PLANS, SPECIFICATIONS, COMPUTER FILES, FIELD DATA, NOTES AND OTHER DOCUMENTS AND INSTRUMENTS PREPARED BY THE CONSULTANT AND INSTRUMENTS PREPARED BY THE CONSULTANT SHALL REMAIN THE PROPERTY OF THE CONSULTANT.
 THE CONSULTANT SHALL BE RESPONSIBLE FOR THE PROTECTION, STORAGE, AND MAINTENANCE OF ALL INSTRUMENTS OF SERVICE.
 INDIVIDUALS ARE NOT TO BE HELD RESPONSIBLE FOR NEGLIGENCE.



DAG ARCHITECTS
DAG Architects, AAC000745
1223 Airport Road Destin, Florida 32541
850.837.8152 www.dagarchitects.com

CONSTRUCTION DOCUMENT

DESTIN FORT WALTON BEACH CONVENTION CENTER
EXTERIOR ACCESSIBILITY
TASK ORDER No. 6b - C18-2638-TDD
1250 MIRACLE STRIP PKWY SE
FORT WALTON BEACH, FL 32548

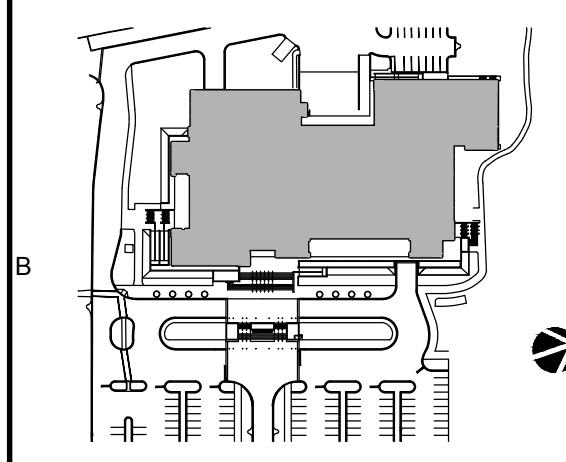

No.	Description	Date

FIRST FLOOR PLAN - ELECTRICAL
Project number: 17057b
Date: 06-12-2020
PHC
PM

1986
Job No.
E301

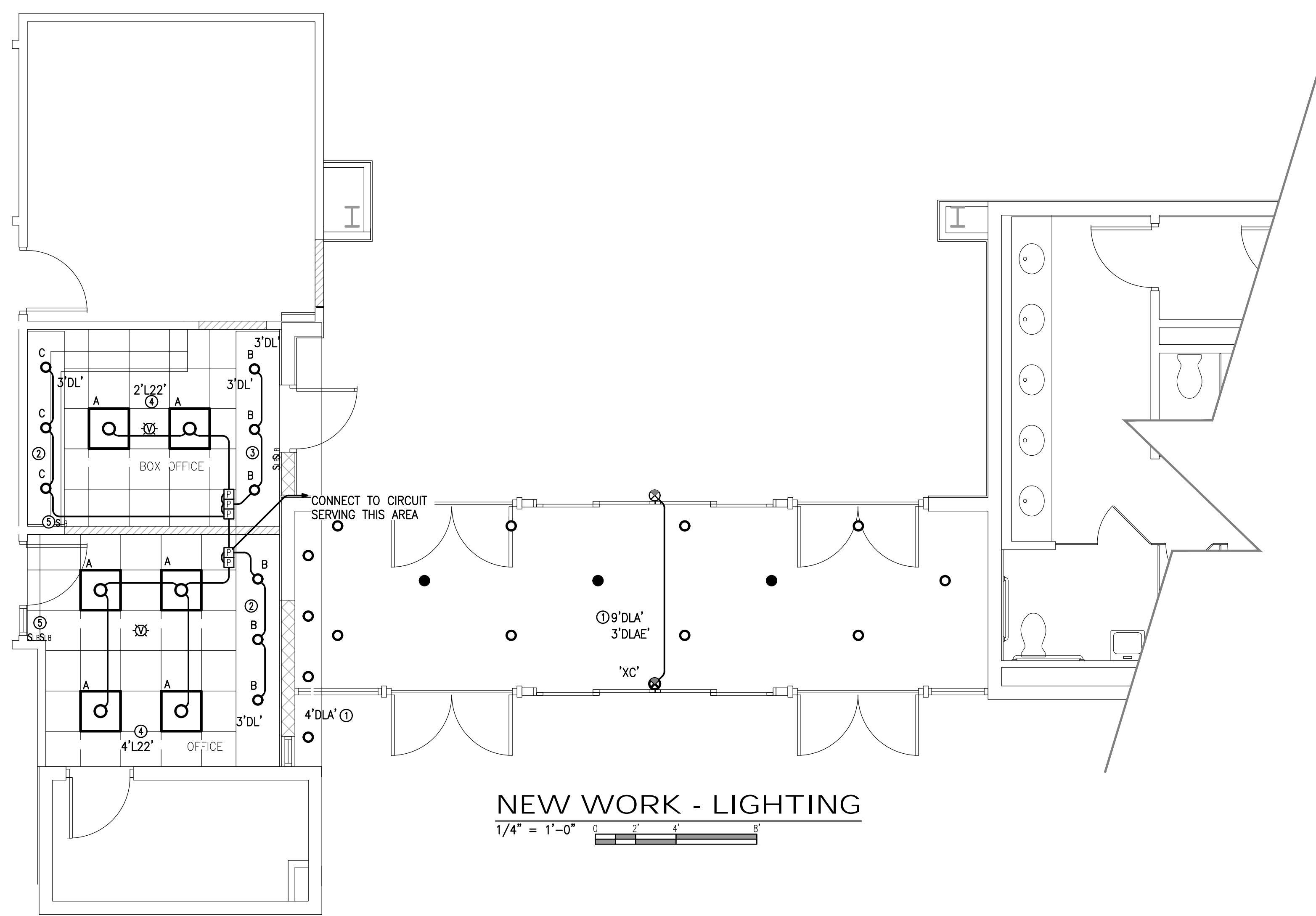

NEW WORK - LIGHTING
1/4" = 1'-0"

- NEW WORK NOTES**
- ① REPLACE EXISTING FIXTURES IN THIS AREA WITH NEW 'DLA' FIXTURES. MAINTAIN EXISTING CONTROLS FOR FIXTURES IN THIS AREA.
 - ② REPLACE EXISTING FIXTURES IN THIS AREA WITH NEW 'DL' FIXTURES. PROVIDE NEW LOW VOLTAGE SWITCHES AND LOW VOLTAGE WIRING FOR NEW 'DL' FIXTURES. REFER TO LIGHTING CONTROL DETAILS.
 - ③ RELOCATE AND INSTALL NEW 'DL' FIXTURES IN THIS AREA. PROVIDE NEW LOW VOLTAGE SWITCHES AND LOW VOLTAGE WIRING FOR NEW 'DL' FIXTURES. PATCH AND REPAIR CEILING. REFER TO LIGHTING CONTROL DETAILS.
 - ④ RELOCATE AND INSTALL NEW L22 FIXTURES IN THIS AREA. PROVIDE NEW LOW VOLTAGE SWITCHES AND LOW VOLTAGE WIRING FOR NEW 'L22' FIXTURES. REFER TO LIGHTING CONTROL DETAILS.
 - ⑤ REPLACE EXISTING SWITCHES IN THIS AREA WITH NEW LOW VOLTAGE SWITCHES. REFER TO LIGHTING CONTROLS DETAIL.
 - ⑥ PROVIDE FIRE ALARM DEVICES COMPATIBLE WITH CURRENT FIRE ALARM SYSTEM

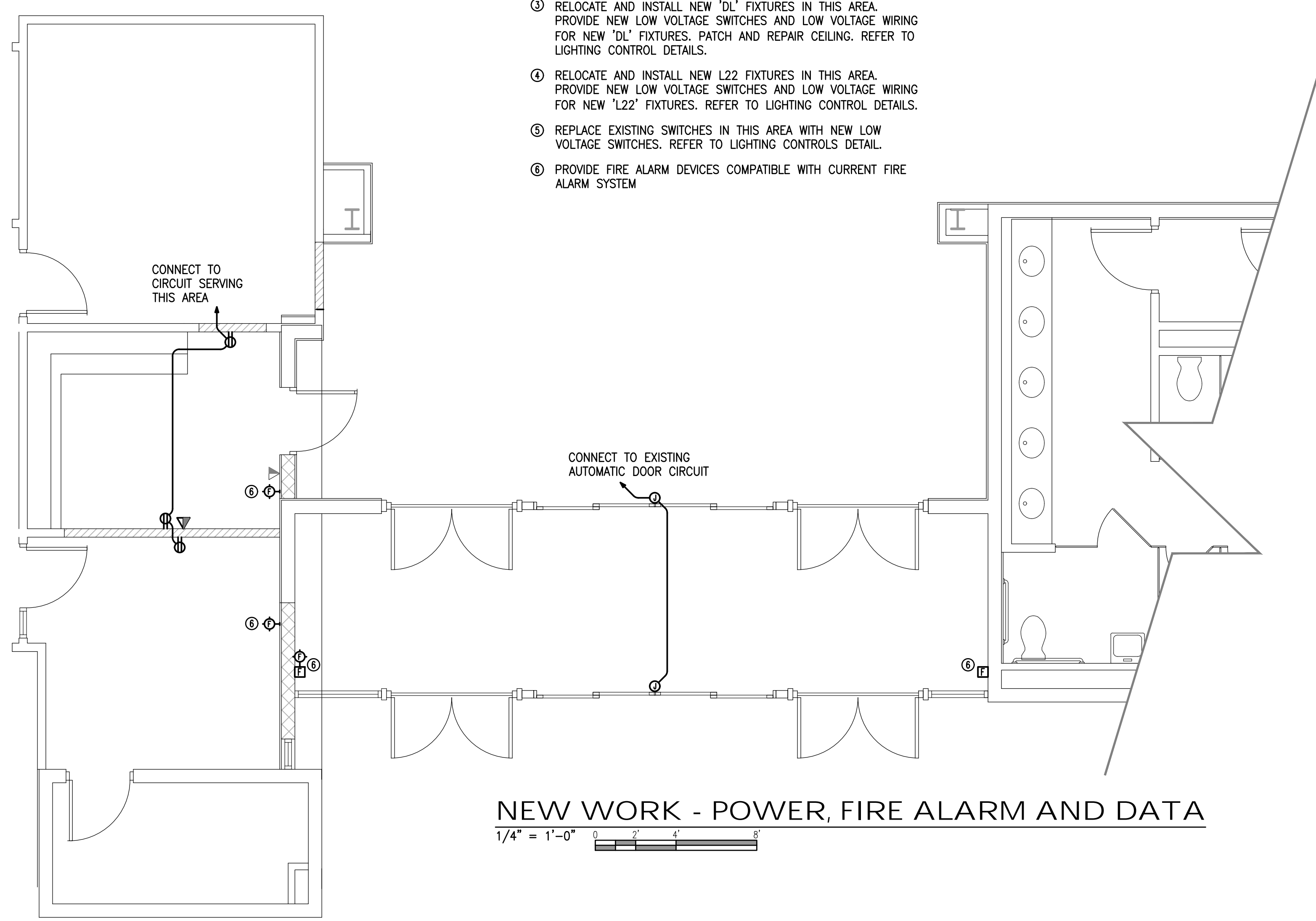

NEW WORK - POWER, FIRE ALARM AND DATA
1/4" = 1'-0"

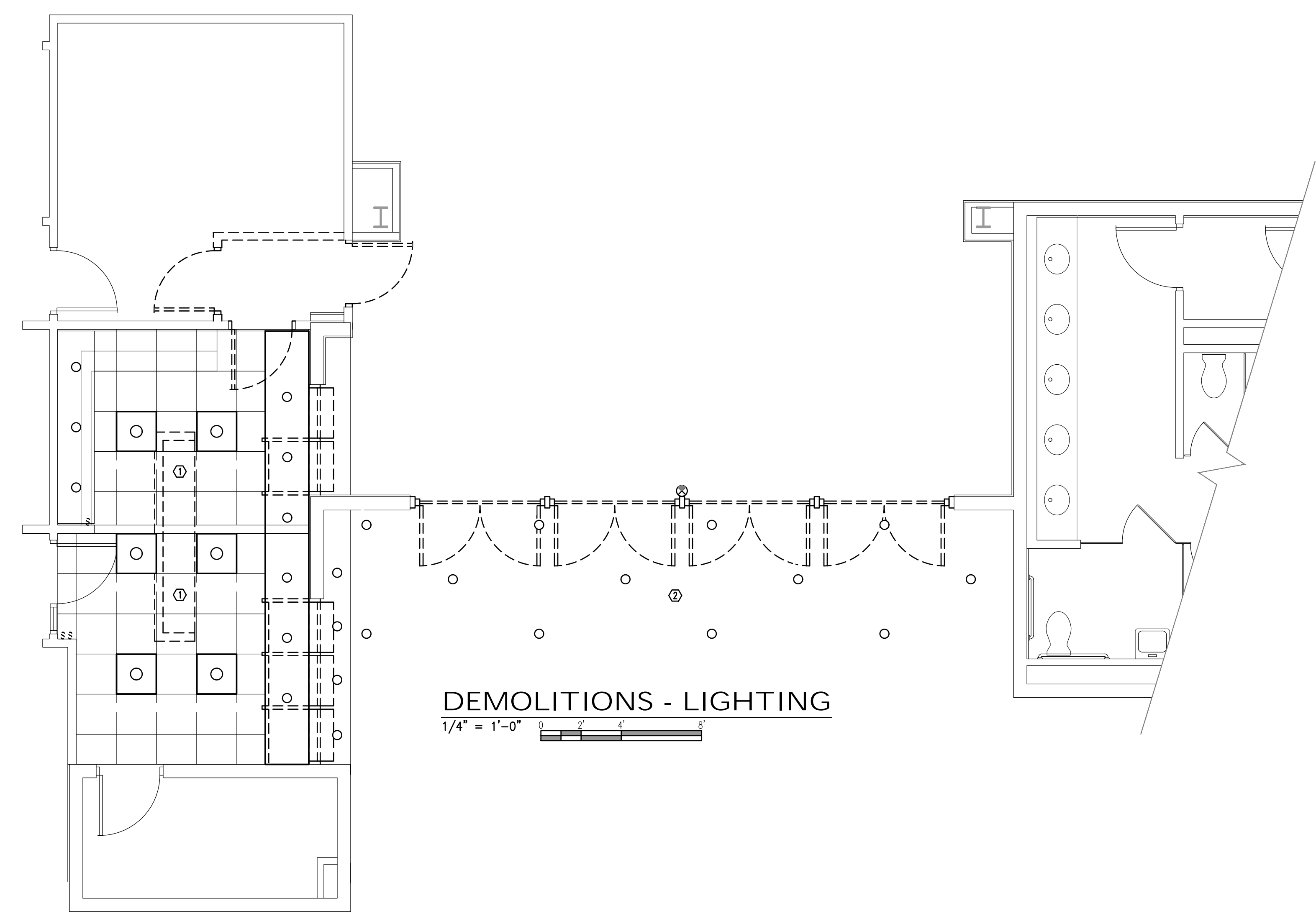

DEMOLITIONS - LIGHTING
1/4" = 1'-0"

- DEMOLITION NOTES**
- ① REMOVE AND REPLACE FIXTURES, AND SWITCHES IN THIS AREA. MAINTAIN CIRCUIT SERVING THIS AREA.
 - ② REMOVE AND REPLACE FIXTURES IN THIS AREA. MAINTAIN CURRENT SWITCH CONTROL AND CIRCUIT SERVING THIS AREA.
 - ③ REMOVE DATA OUTLET, RECEPTACLE AND WIRING.
 - ④ DISCONNECT AND REMOVE ADA CONTROL.

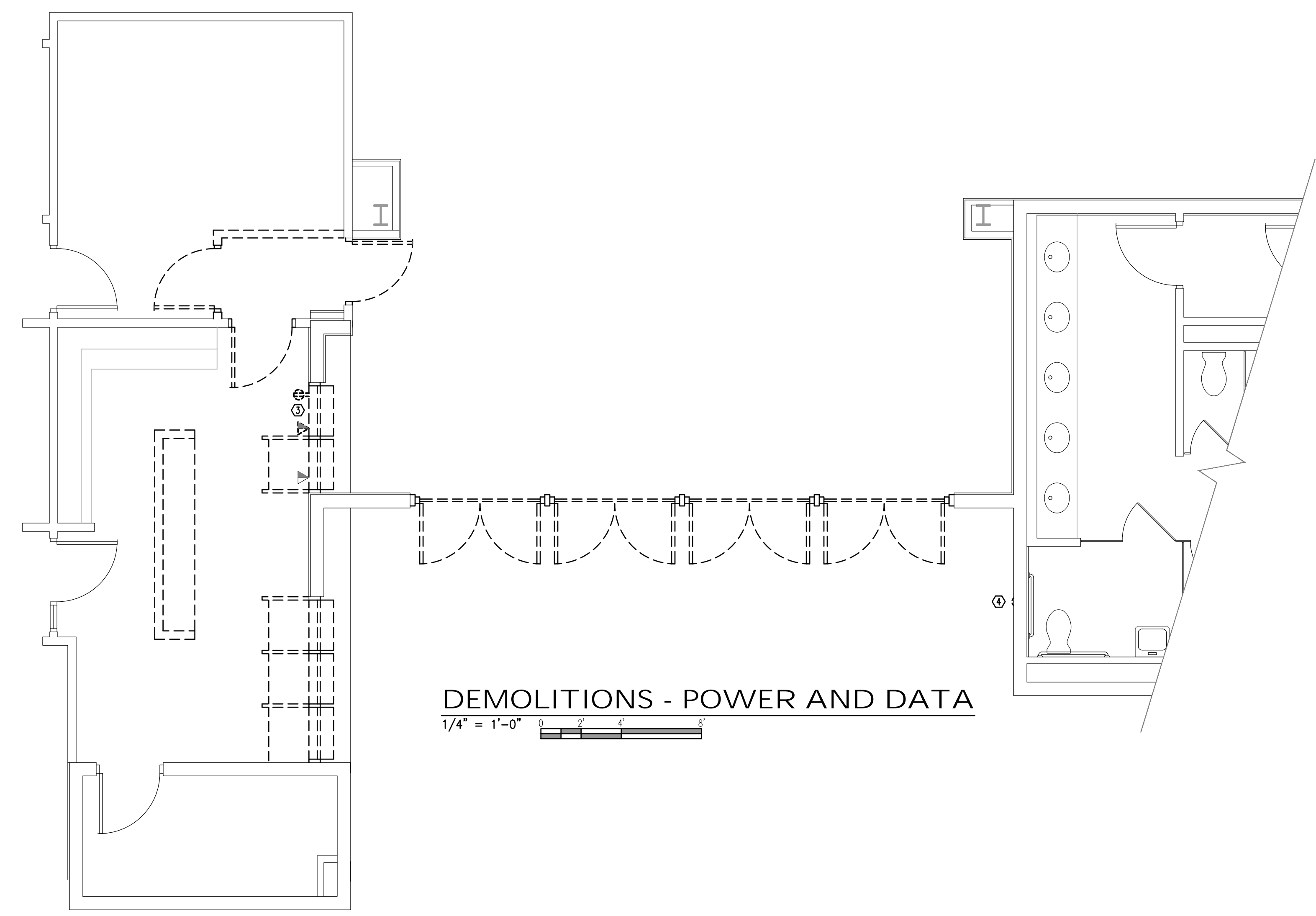

DEMOLITIONS - POWER AND DATA
1/4" = 1'-0"



1986
Job No.

CONSERVATION OF INSTRUMENTS OF SERVICE
ALL REPORTS, PLANS, SPECIFICATIONS, COMPUTER FILES, FIELD DATA, NOTES AND OTHER DOCUMENTS AND INSTRUMENTS PREPARED BY THE CONSULTANT AND INSTRUMENTS PREPARED BY THE CONSULTANT SHALL REMAIN THE PROPERTY OF THE CONSULTANT.
THE CONSULTANT SHALL RETAIN ALL RIGHTS, TITLE AND INTEREST IN ANY PATENTS, TRADEMARKS, COPYRIGHTS, OR OTHER INTELLECTUAL PROPERTY RIGHTS THAT MAY BE IN OR ASSOCIATED WITH ANY INSTRUMENTS OF SERVICE.
INDIVIDUALLY LIABLE FOR NEGLIGENCE

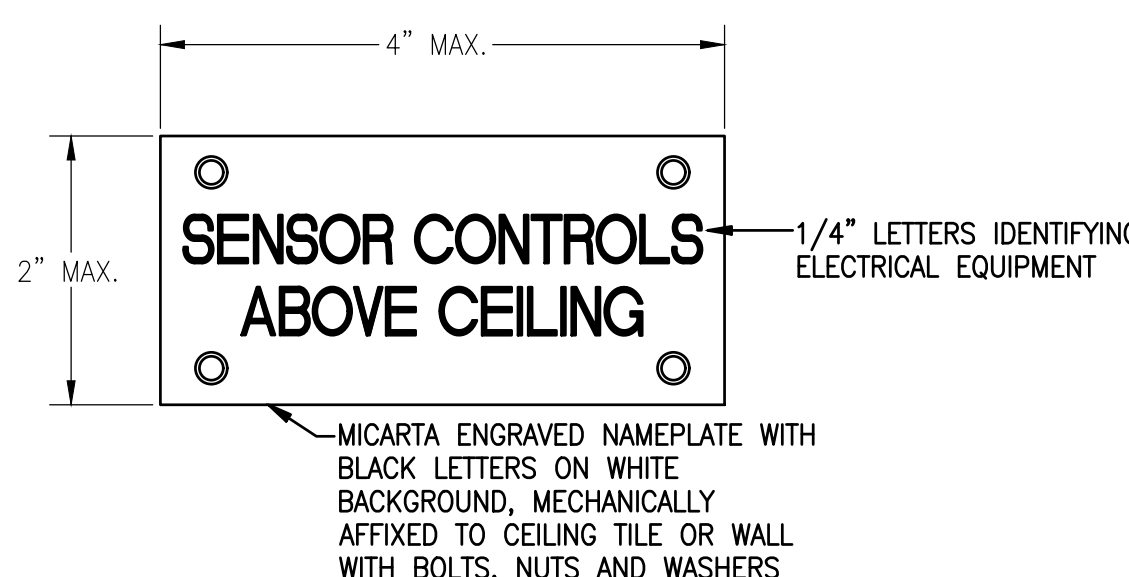
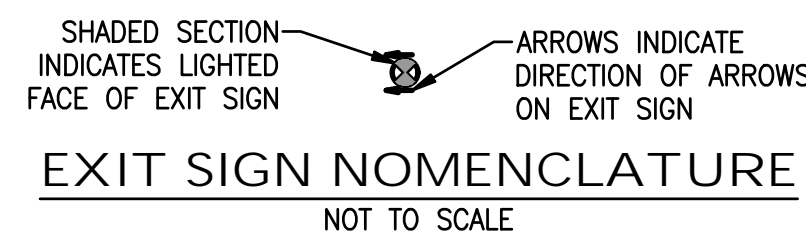

TYPICAL ELECTRICAL EQUIPMENT ABOVE CEILING NAMEPLATE
NOT TO SCALE

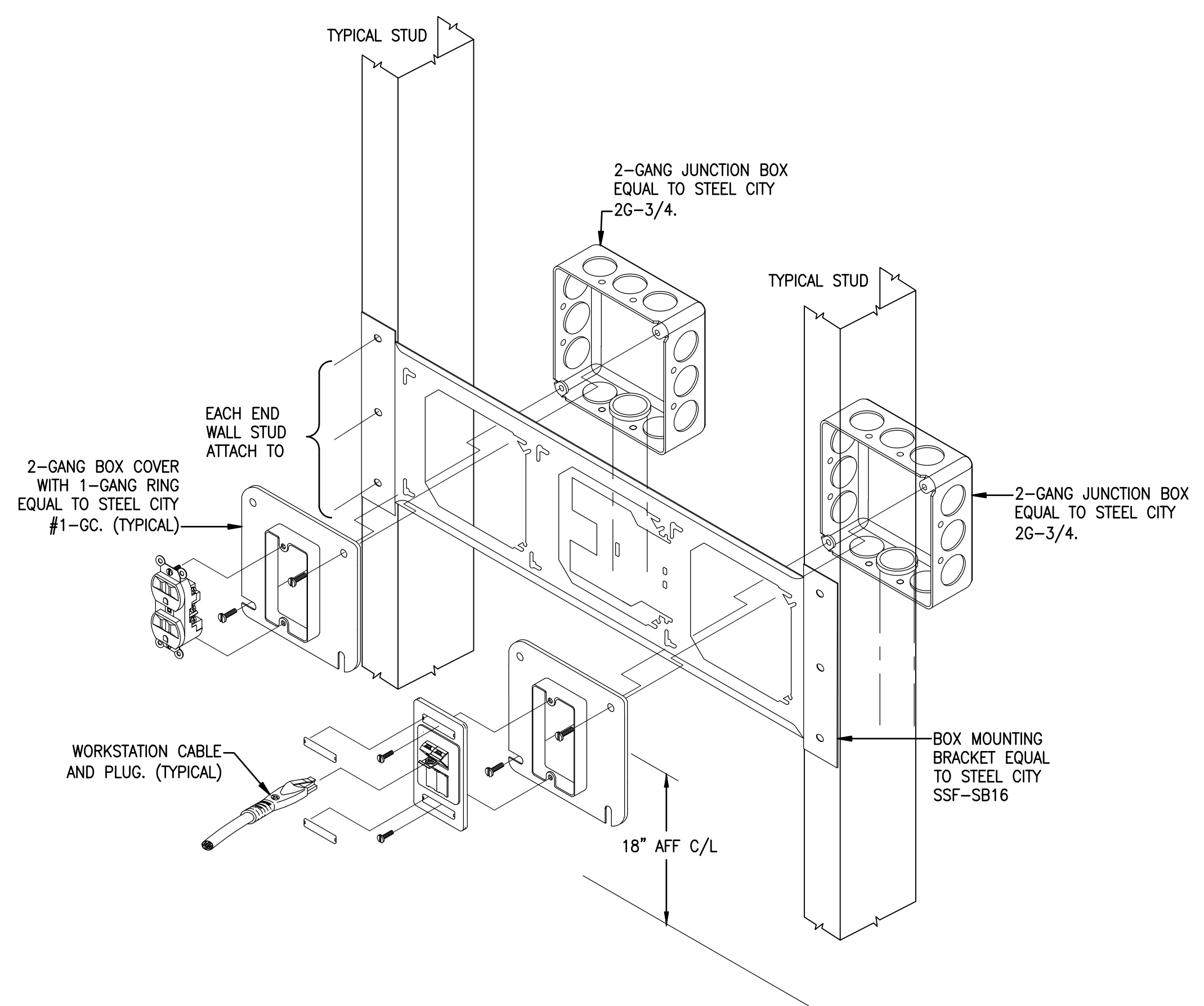

TYPICAL POWER & COMMUNICATIONS
NOT TO SCALE

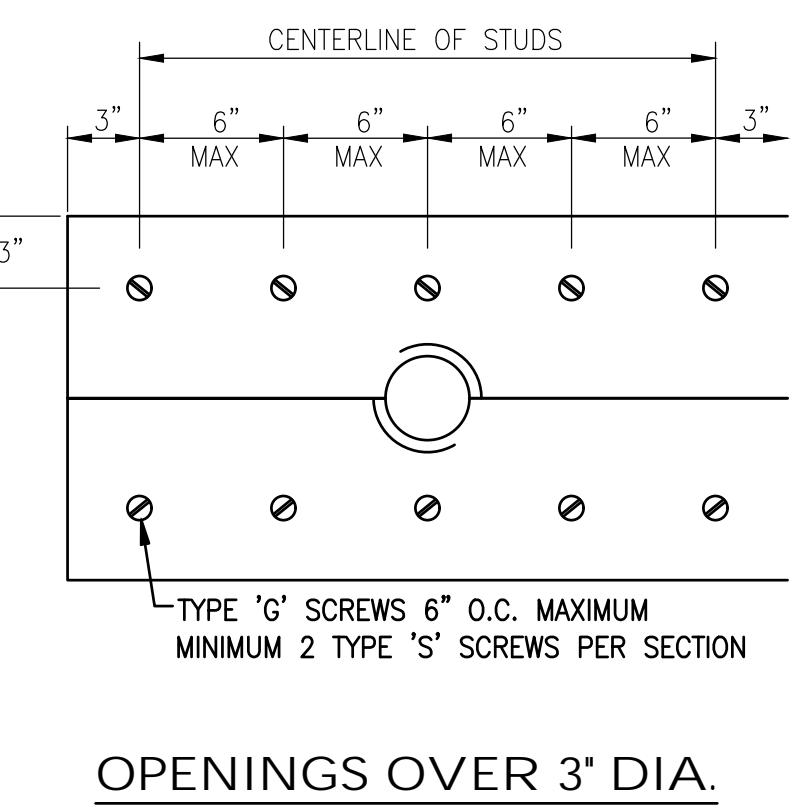
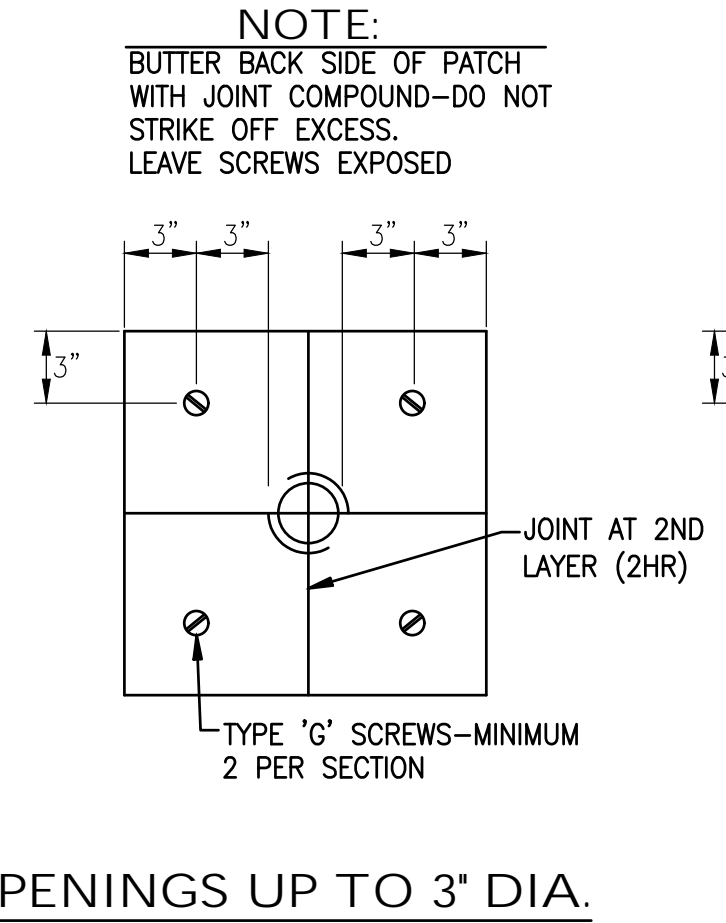
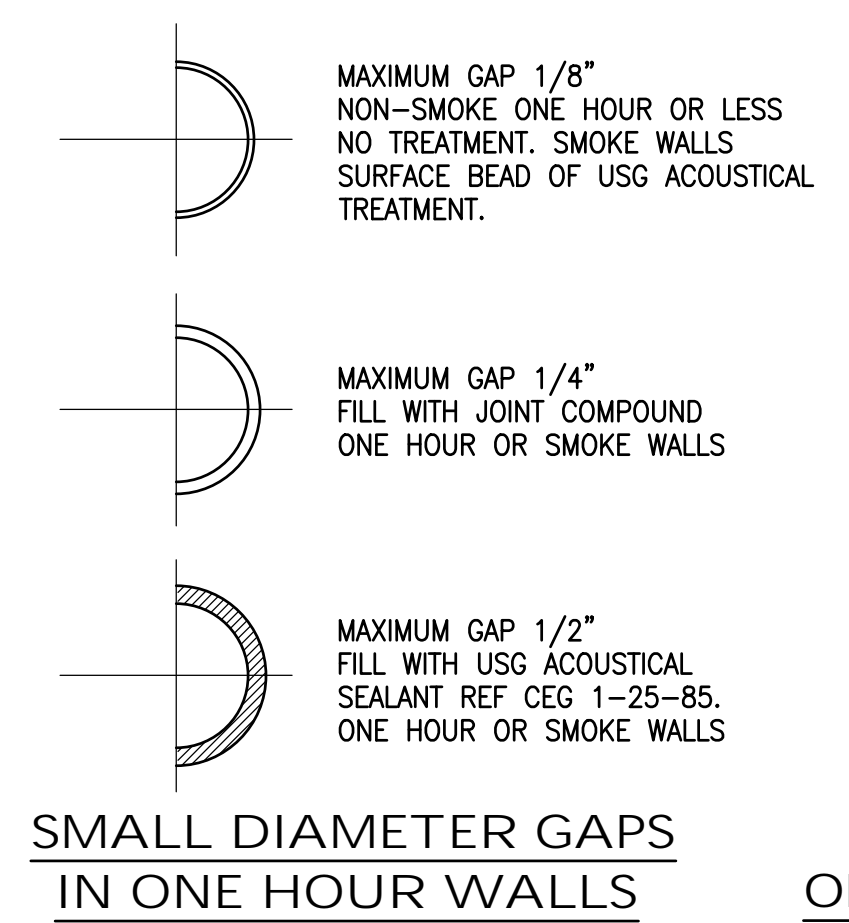

OPENINGS UP TO 3' DIA.
OPENINGS OVER 3' DIA.

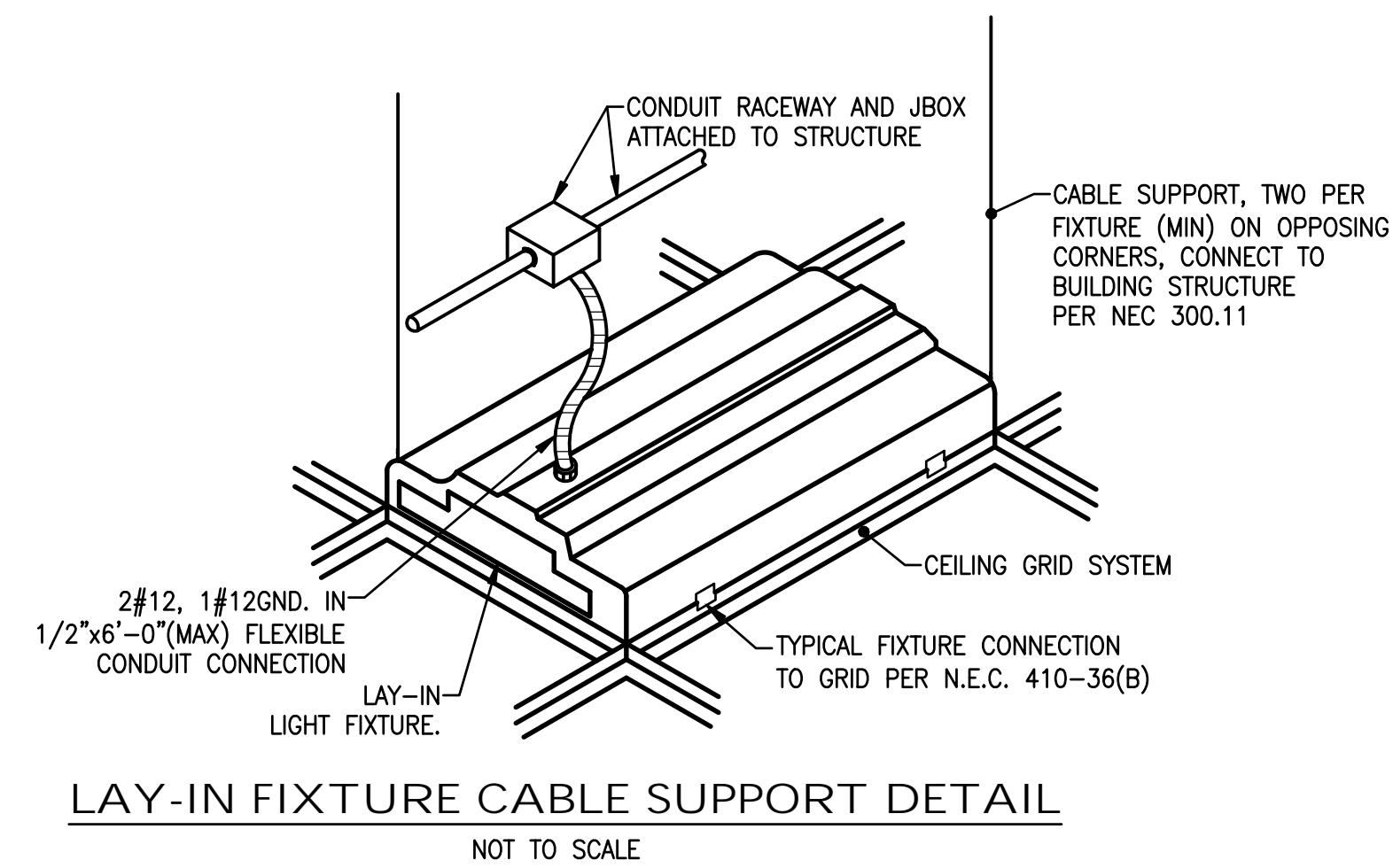

LAY-IN FIXTURE CABLE SUPPORT DETAIL
NOT TO SCALE

WALL PENETRATIONS -APPLIES TO ALL CORRIDOR, SMOKE AND FIRE RATED WALLS
NOT TO SCALE

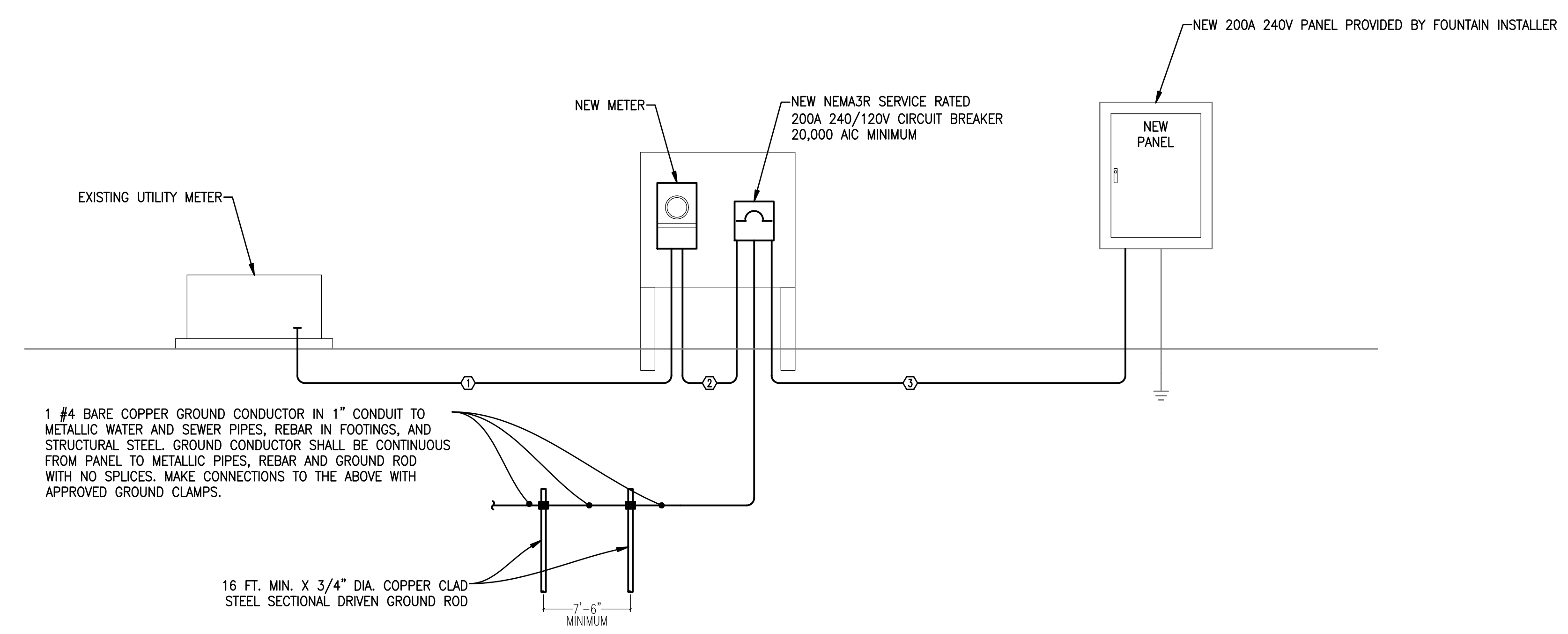

SINGLE LINE POWER RISER
NOT TO SCALE

*** SPECIAL NOTE ***
PROVIDE 'LSI' TRIP UNITS FOR BREAKERS GREATER THAN OR EQUAL TO 200A.

DESIGNATION	FEEDER SCHEDULE									
	EQUIPMENT	BREAKER	CONDUCTOR / CONDUIT SIZE							
			TRIP	POLE	BUS	CONDUIT	QTY.	SIZE	GND	MATERIAL
1	METER	200	3	1	2"	3	E300	-	CU	
2	METER	200	2	1	2"	3	E300	-	CU	
3	ENCLOSURE BREAKER	200	2	1	2"	3	E300	#6	CU	



CONSTRUCTION DOCUMENT

DESTIN FORT WALTON BEACH CONVENTION CENTER
EXTERIOR ACCESSIBILITY
TASK ORDER No. 66 - C18-2638-TDD
1250 MIRACLE STRIP PKWY SE
FORT WALTON BEACH, FL 32548

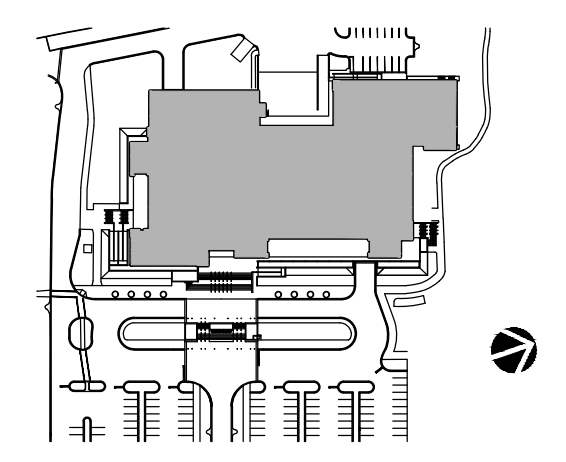

No.	Description	Date

ELECTRICAL DETAILS AND RISER
Project number: 17057b
Date: 06-12-2020
PIC
PM
1986
Job No.
E401



ALL REPORTS, PLANS, SPECIFICATIONS, COMPUTER FILES, FIELD DATA, NOTES AND OTHER DOCUMENTS AND INSTRUMENTS PREPARED BY THE CONSULTANT ARE INSTRUMENTS OF SERVICE. THE CONSULTANT SHALL REMAIN THE PROPERTY OF THE CONSULTANT. THE CONSULTANT SHALL NOT BE RESPONSIBLE FOR ANY REVISIONS OR CORRECTIONS TO ANY INSTRUMENTS OF SERVICE THAT ARE MADE BY ANY OTHER PARTY WITHOUT THE WRITTEN CONSENT OF THE CONSULTANT. THE CONSULTANT SHALL NOT BE RESPONSIBLE FOR ANY REVISIONS OR CORRECTIONS TO ANY INSTRUMENTS OF SERVICE THAT ARE MADE BY ANY OTHER PARTY WITHOUT THE WRITTEN CONSENT OF THE CONSULTANT.



CONSTRUCTION DOCUMENT

DESTIN FORT WALTON BEACH CONVENTION CENTER

EXTERIOR ACCESSIBILITY
TASK ORDER No. 6b - C18-2638-TDD
1250 MIRACLE STRIP PKWY SE
FORT WALTON BEACH, FL 32548

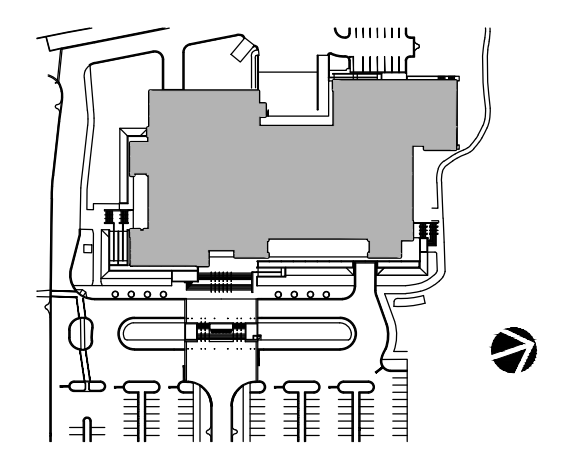

Table with 3 columns: No., Description, Date. Contains empty rows for schedule entries.

LIGHTING CONTROLS AND FIXTURE SCHEDULE

Project number: 17057b
Date: 06-12-2020
P/C:
PM



H.C. ENGINEERS
145 E. Highway 9E
Fort Walton Beach, Florida, 32548
E-mail: office@hce-engineers.com
Ph: 850.243.6723 Fax: 850.954.5420
FL Authorization No. 00066600
Christopher A. Garick, FL PE No. 53924
Thomas A. Alexander, FL PE No. 73172
Daniel J. White, FL PE No. 73796

LIGHTING FIXTURE SCHEDULE table with columns: Luminaire Designation, Manufacturer, Catalog Number, Connected Voltage, Luminaire Load (va), Lamping Source, Color Rendering Index (CRI), Kelvin Temperature, Mounting, Comments.

Lighting Space and Zones table with columns: Space Type, Room Number, Description, Designator, Manual On, Manual Off, Dimming, Multi-Level Control, Timedlock On, Timedlock Off, Occupancy Sensor On, Vacancy Sensor Off, Daylight Harvesting, Photo Sensor On, Fire Alarm System Override to On, Security System Override to On, SLS (2-Button), SLS (4-Button), SLS (6-Button), Remarks.

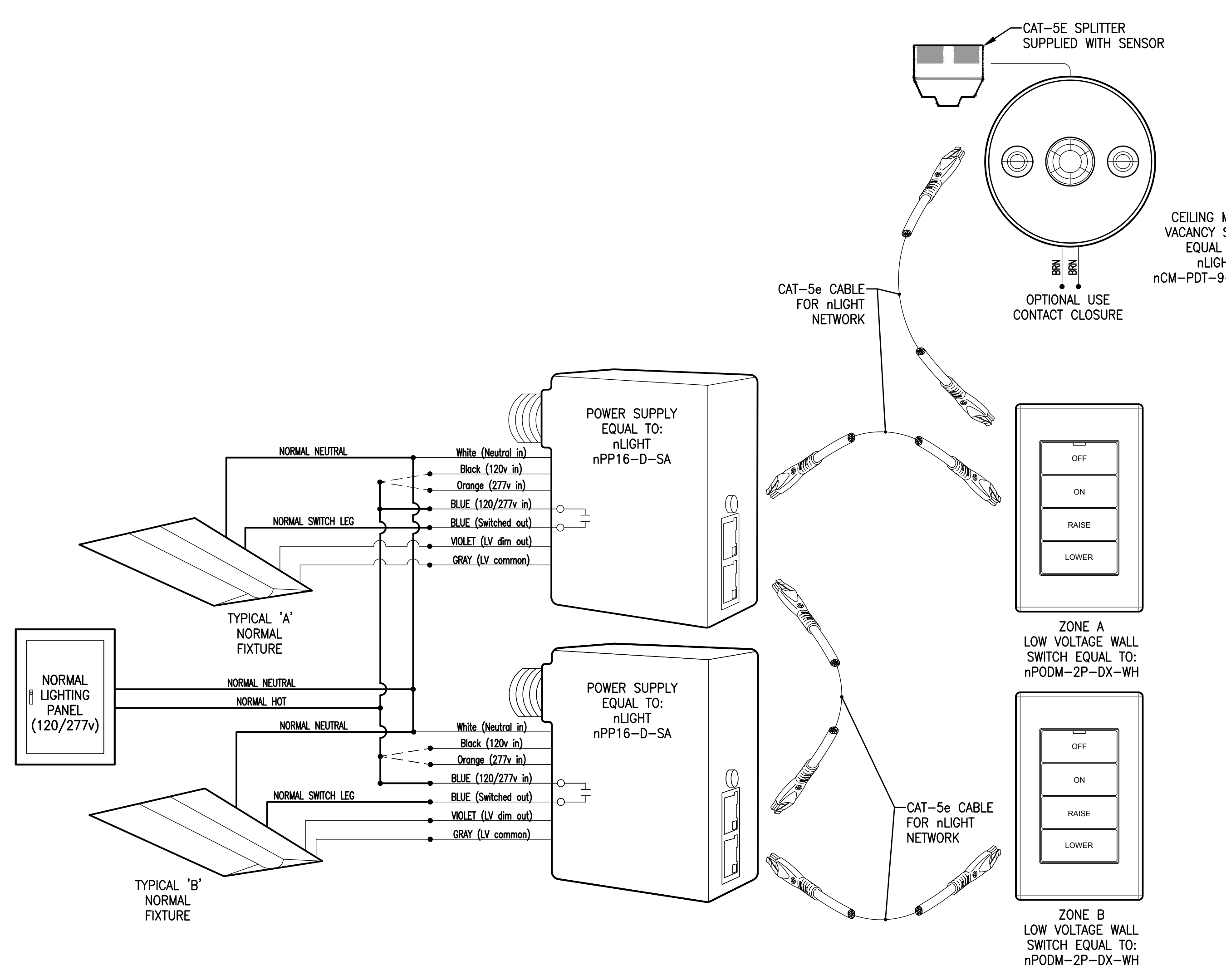

ENCLOSED OFFICE AREA LIGHTING (SWITCHING) CONTROL WITH OCC SENSOR, AND SWITCH INPUT

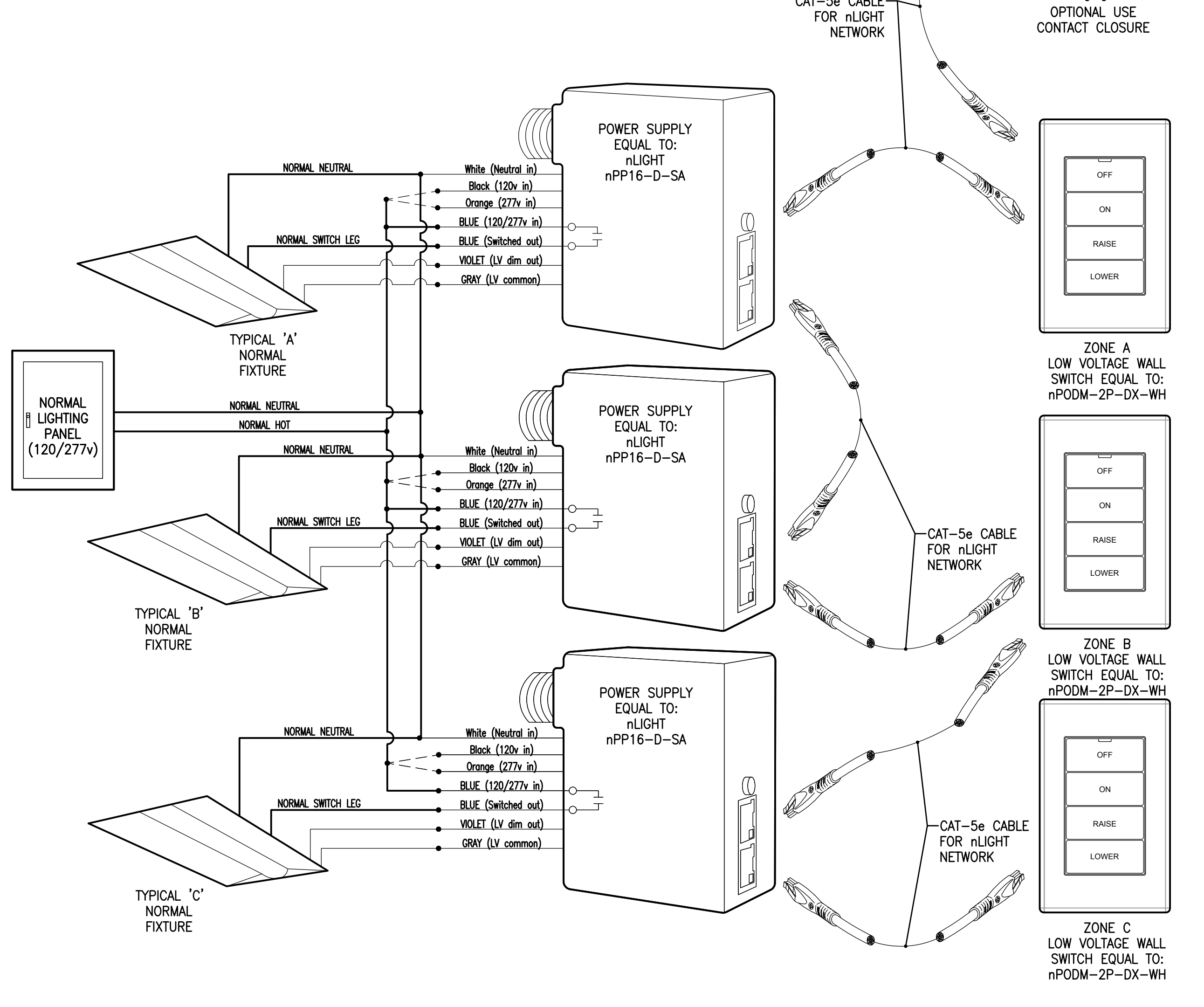

BOX OFFICE ROOM AREA NORMAL LIGHTING (SWITCHING) CONTROL WITH OCC SENSOR AND SWITCH INPUT

ALL REPORTS, PLANS, SPECIFICATIONS, COMPUTER FILES, FIELD DATA, NOTES AND OTHER DOCUMENTS AND INSTRUMENTS PREPARED BY THE CONSULTANT SHALL REMAIN THE PROPERTY OF THE CONSULTANT. THE CONSULTANT SHALL BE RESPONSIBLE FOR THE PROTECTION OF ALL INSTRUMENTS AND EQUIPMENT. IT IS THE RESPONSIBILITY OF THE CONSULTANT TO PROTECT AND MAINTAIN ALL INSTRUMENTS AND EQUIPMENT. ANY INSTRUMENTS OR EQUIPMENT THAT ARE DAMAGED OR LOST SHALL BE REPLACED AT THE CONSULTANT'S EXPENSE.

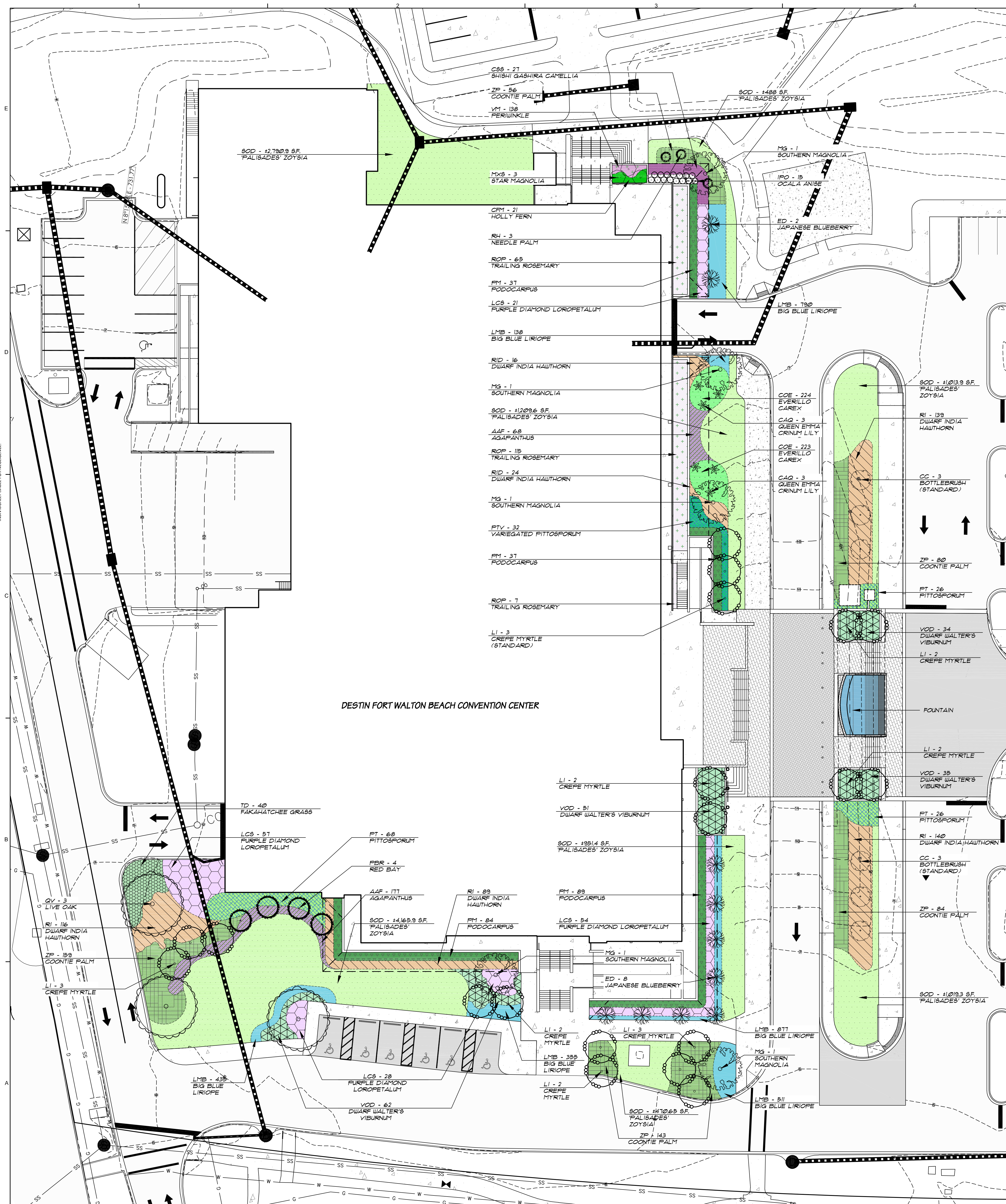

DESTIN FORT WALTON BEACH CONVENTION CENTER

PLANTING SCHEDULE:

REFER TO THE ORTHO PROBLEM SOLVER PUBLISHED BY THE MONSANTO CO. OR ORTHO INFORMATION SERVICES, SAN FRANCISCO, CA (800) 225-2883 FOR RECOMMENDED CONTROL TREATMENTS FOR SPECIFIC PESTS AND DISEASES IDENTIFIED IN THE MAINTENANCE GUIDELINES OR CONTACT THE OKALOOSA COUNTY EXTENSION SERVICE OF IFAS.

Table with columns: SYMBOL, QUANTITY, BOTANICAL NOMENCLATURE, COMMON NAME, SPACING & SIZE. Includes entries for TREES & PALMS and SHRUBS.

SHRUBS

Table with columns: SYMBOL, QUANTITY, BOTANICAL NOMENCLATURE, COMMON NAME, SPACING & SIZE. Lists various shrub species and their planting specifications.

GROUNDCOVERS AND VIRES

Table with columns: SYMBOL, QUANTITY, BOTANICAL NOMENCLATURE, COMMON NAME, SPACING & SIZE. Lists groundcover and vine species.

PLANTING NOTES:

- 1. LOCATE ALL UNDERGROUND UTILITIES... 2. INSTALL AN AUTOMATIC UNDERGROUND DRIP... 3. INSTALL ONLY PLANTS GRADED FLORIDA NO1 OR BETTER... 4. PLANT SHRUBS IN CIRCULAR PITS... 5. FERTILIZE ALL TREES WITH AGRIFORM... 6. BACKFILL ALL PLANTING PITS... 7. APPLY 1" DEEP TRANSLANT MYCORRHIZAL NODULES... 8. FERTILIZE ALL PLANTING BEDS... 9. TREAT ALL PLANTING BEDS WITH PRE-EMERGENT AND POST-EMERGENT HERBICIDES... 10. MULCH PLANTING BEDS... 11. VERIFY ALL QUANTITIES... 12. NOTIFY THE OWNER... 13. QUARANTEE ALL PLANTS... 14. ALL PLANTS MATERIALS... 15. DO NOT MAKE SUBSTITUTIONS... 16. MAINTAIN ALL PLANTING... 17. THESE ARE RESERVED...

PALM TRANSPLANTING REQUIREMENTS & ALLOWANCE:

THE CONTRACTOR SHALL PROVIDE AN ALLOWANCE IN THE BID TO TRANSPLANT APPROXIMATELY 24 EXISTING SABAL PALMS FROM THE LOCATIONS NEAR THE MAIN BUILDING AS IDENTIFIED ON SITE BY THE OWNER AND LANDSCAPE ARCHITECT.

HORTON HODGES



West Studio 52 Okeechobee East Santa Rosa Beach, FL 32359 (850) 699-1297

East Studio P.O. Box 611052 Rosemary Beach, FL 32461 (850) 528-1925

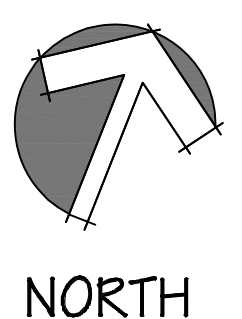
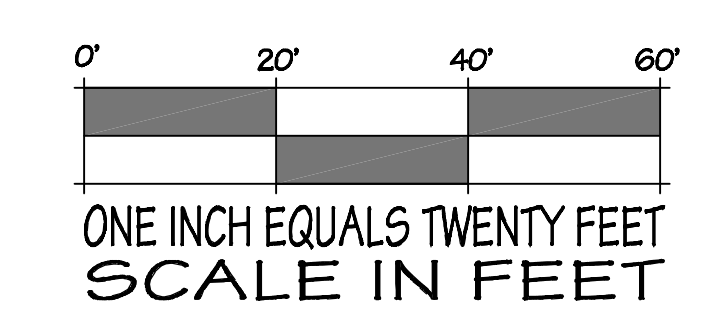

DAG ARCHITECTS logo and contact information: 1223 Airport Road, Destin, Florida 32541, 850.837.8152, www.dagarchitects.com

CONSTRUCTION DOCUMENT

DESTIN FORT WALTON BEACH CONVENTION CENTER PLANTING PLAN & SCHEDULE EXTERIOR ACCESSIBILITY TASK ORDER NO. 6b - C-18-2638-TDD 1250 MIRACLE STRIP PKWY SE FORT WALTON BEACH, FL 32548

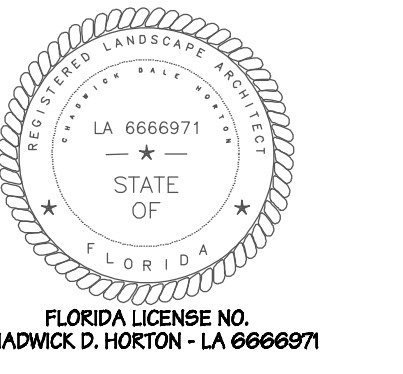
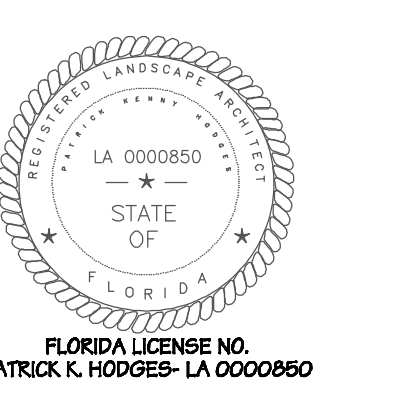

Table with columns: No., Description, Date. Row 1: 1, PLANTING PLAN, 8/12/2020.

Project number: 17057.6b Date: 06-12-2020





ARCHITECTS
DAG Architects, AAC000745
1223 Airport Road Destin, Florida 32541
850.837.8152 www.dagarchitects.com

CONSTRUCTION DOCUMENT

DESTIN FORT WALTON BEACH CONVENTION CENTER

PLANT IMAGE BOARD

EXTERIOR ACCESSIBILITY

TASK ORDER No. 6b - C-18-2638-TDD
1250 MIRACLE STRIP PKWY SE
FORT WALTON BEACH, FL 32548

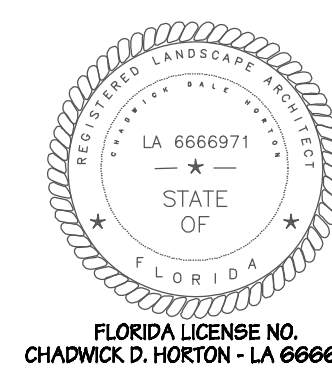
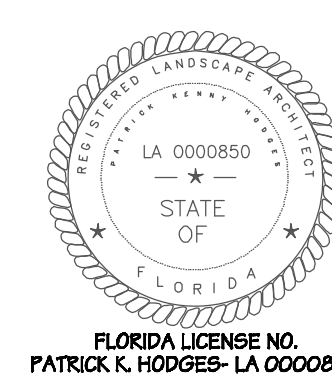

No.	Description	Date
1	PLANT IMAGE BOARD	6/12/2020

Project number: 17057.6b
Date: 06-12-2020
PIC
PM

L2

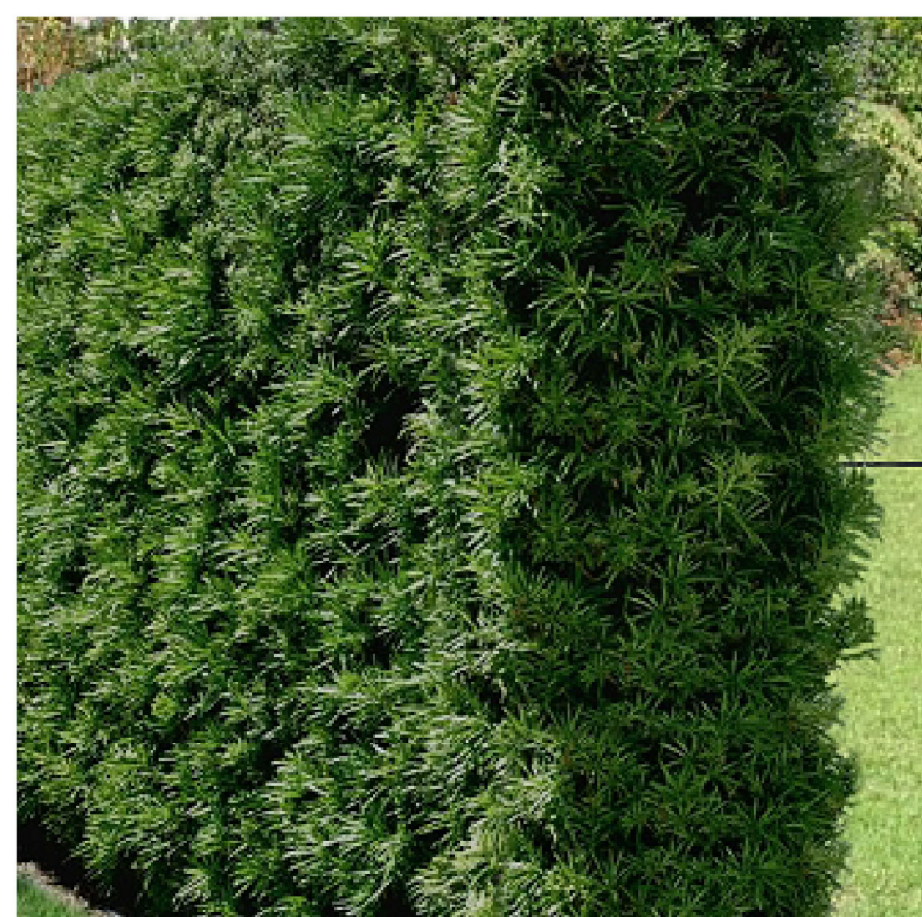

podocarpus



live oak



japanese blueberry

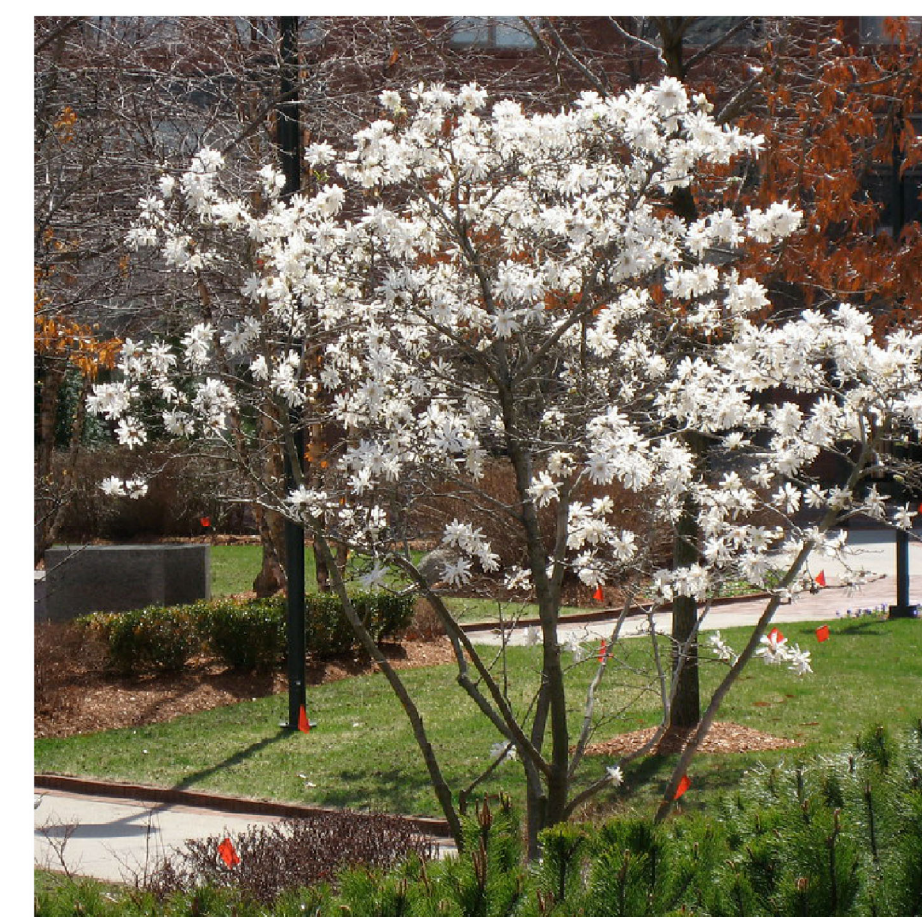

star magnolia



needle palm

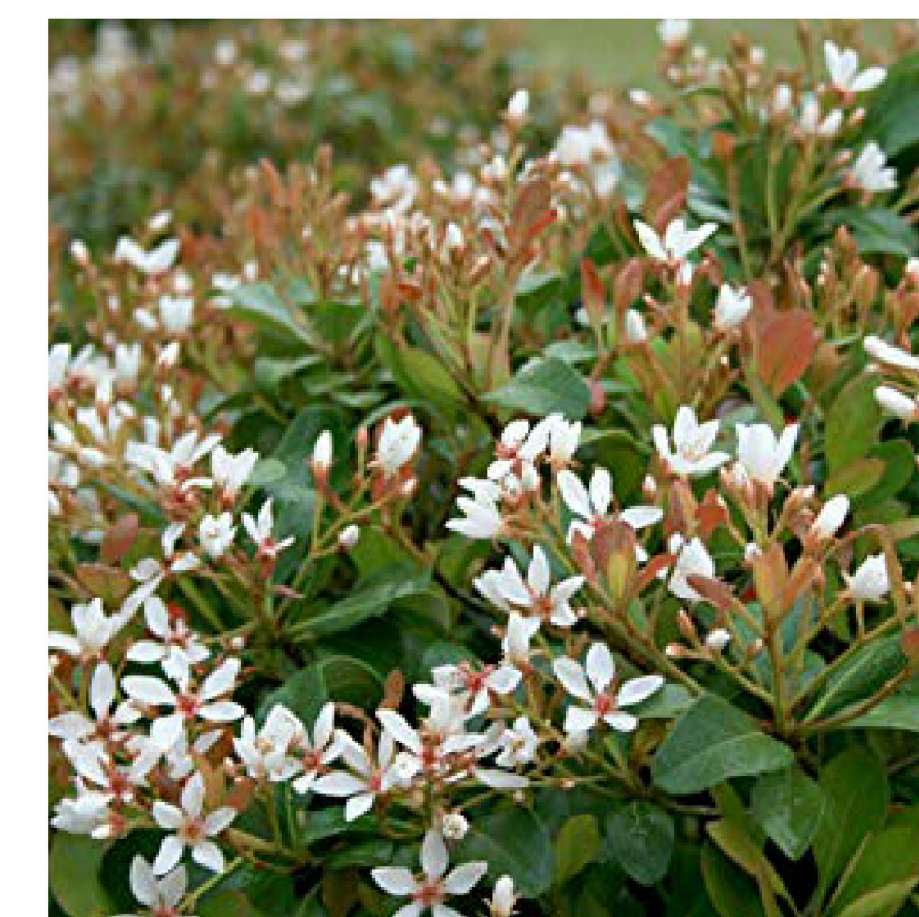

dwarf india hawthorn



dwarf walter's viburnum



'd.d. blanchard' magnolia



crepe myrtle



carex everillo

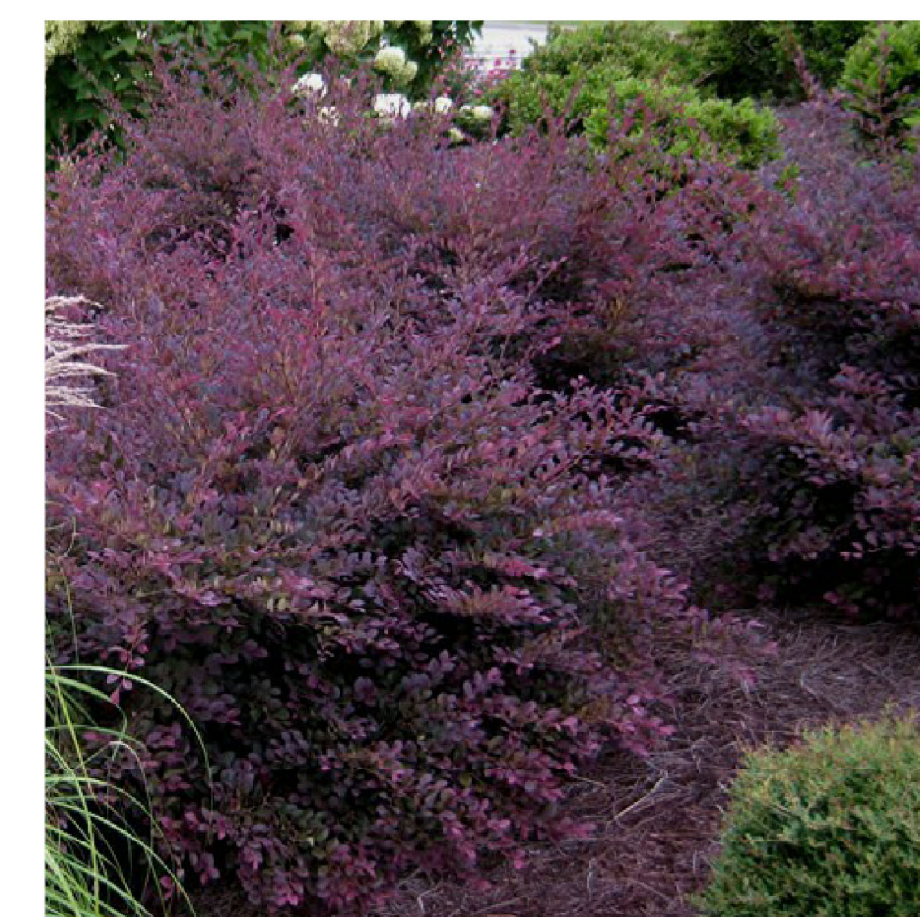

purple diamond loropetalum



crimson bottlebrush



big blue liriope

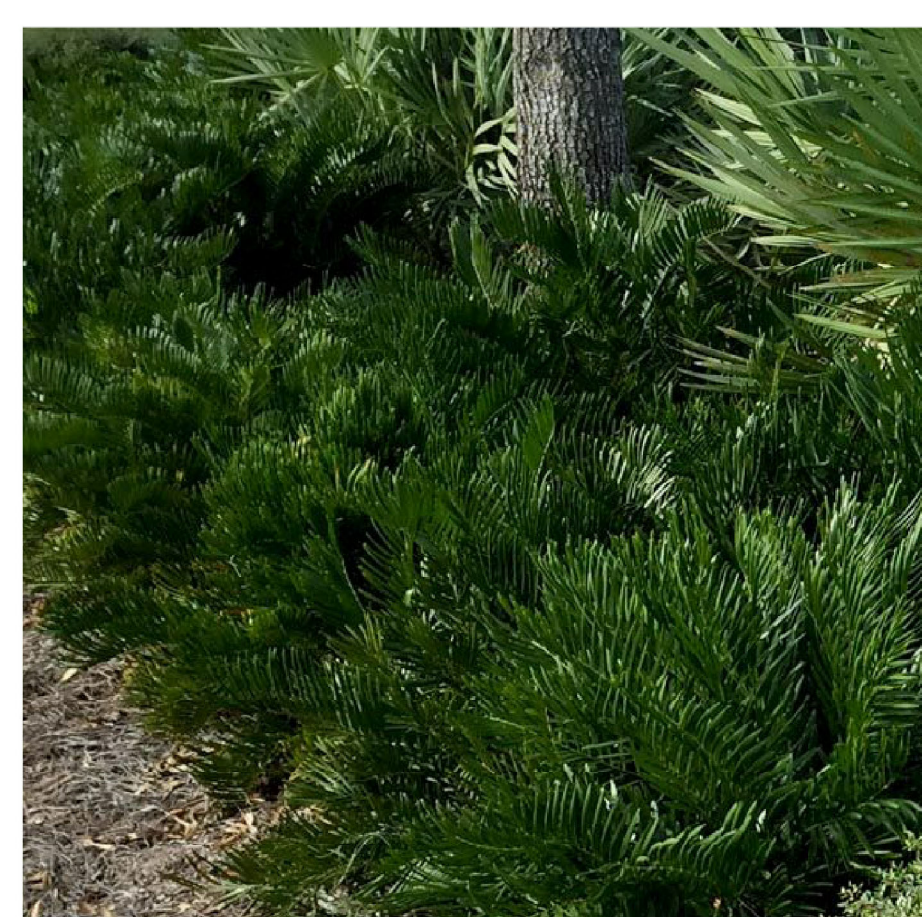

coontie palm

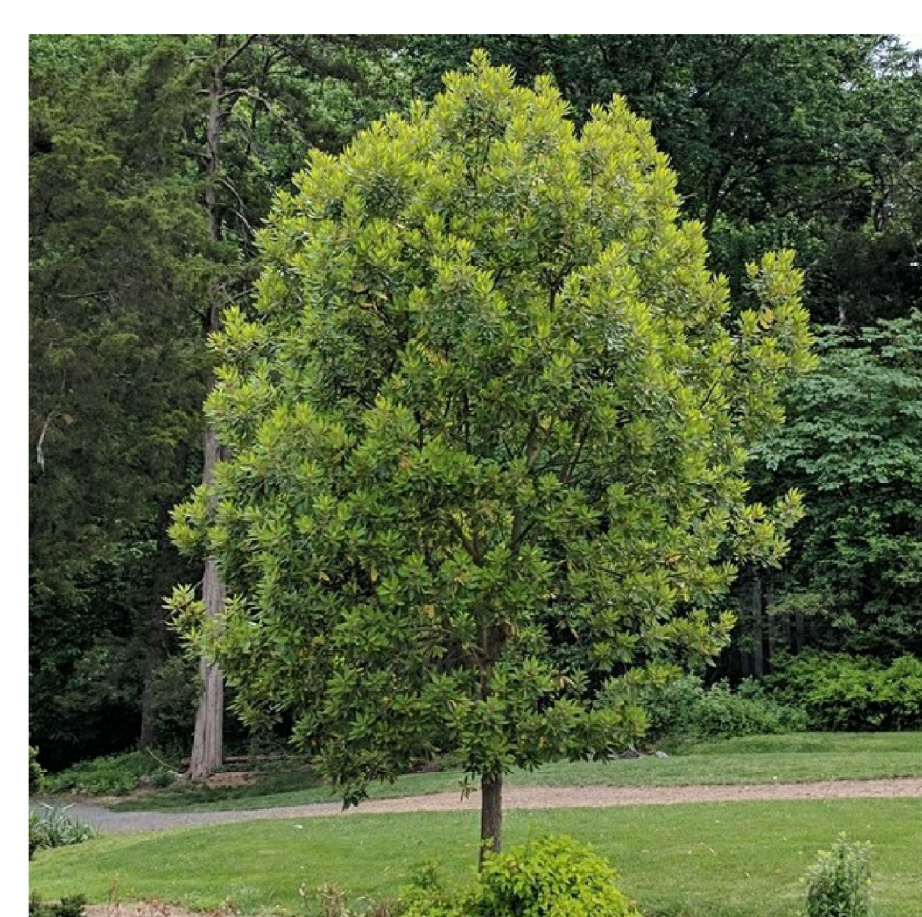

red bay



trailing rosemary



fakahatchee grass

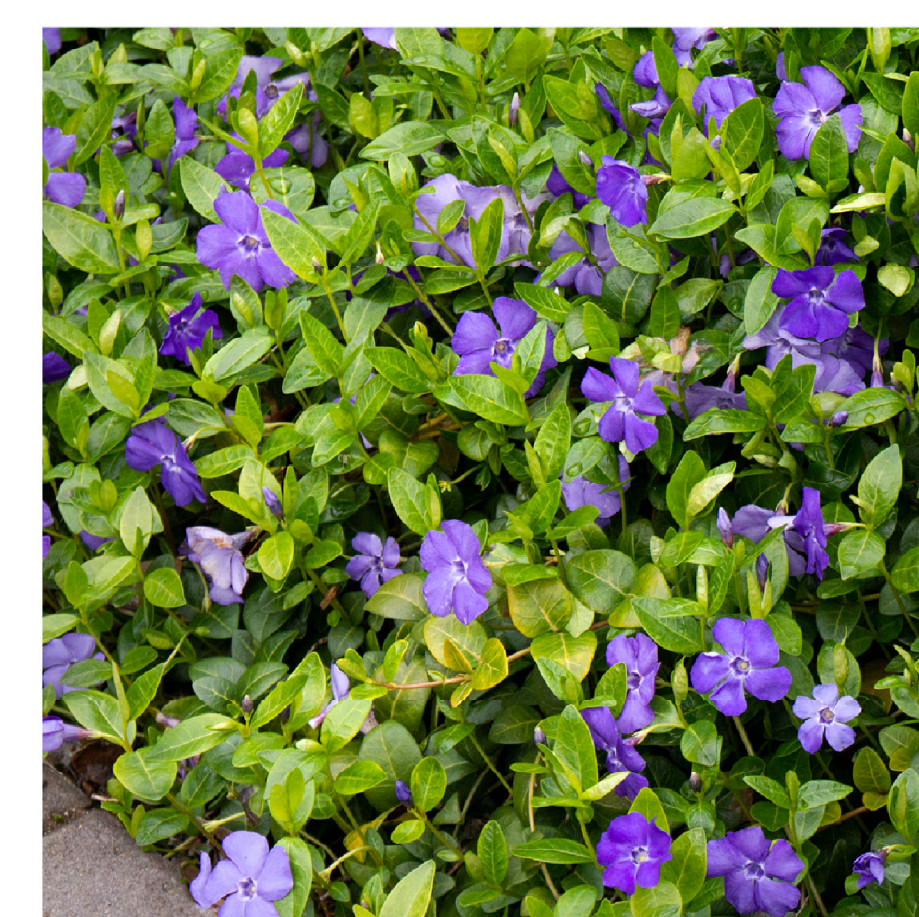

periwinkle



agapanthus

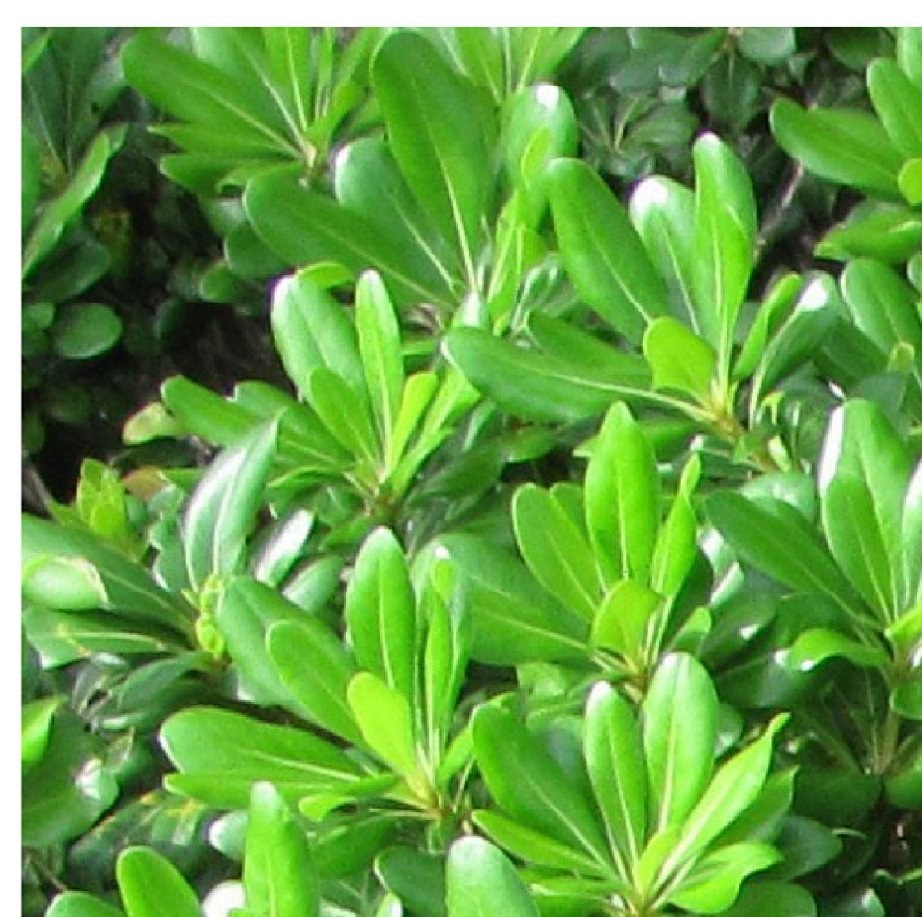

green pittosporum



holly fern

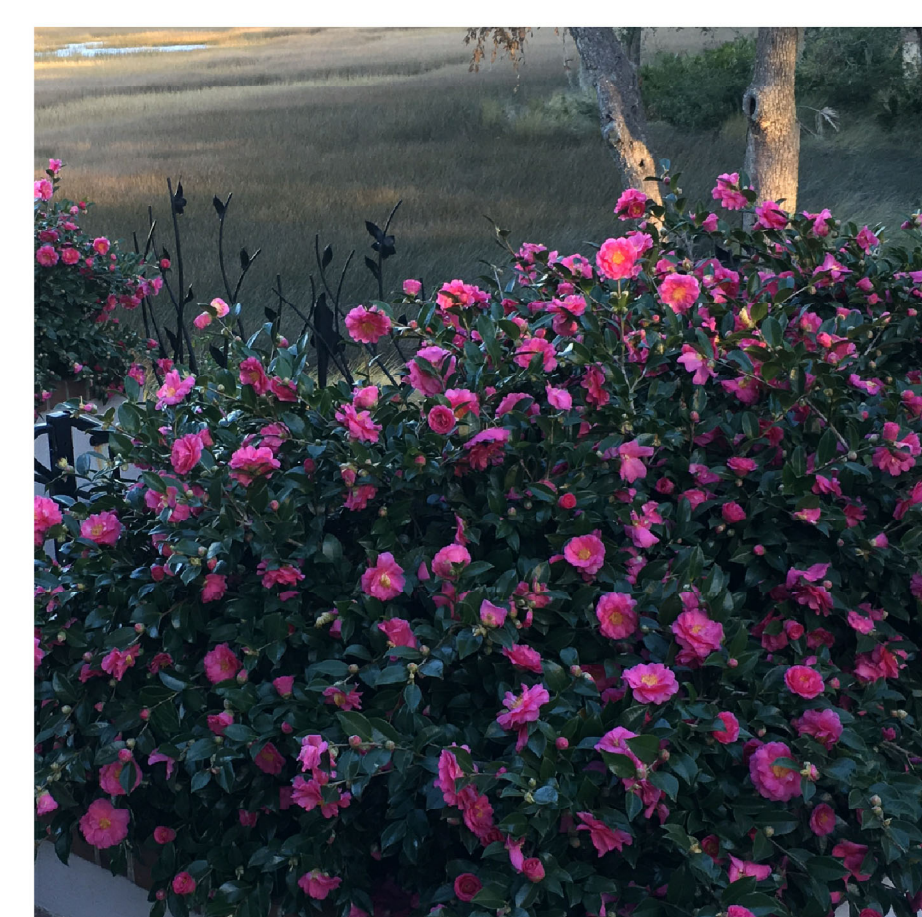

shishi gashira camellia



ocala anise

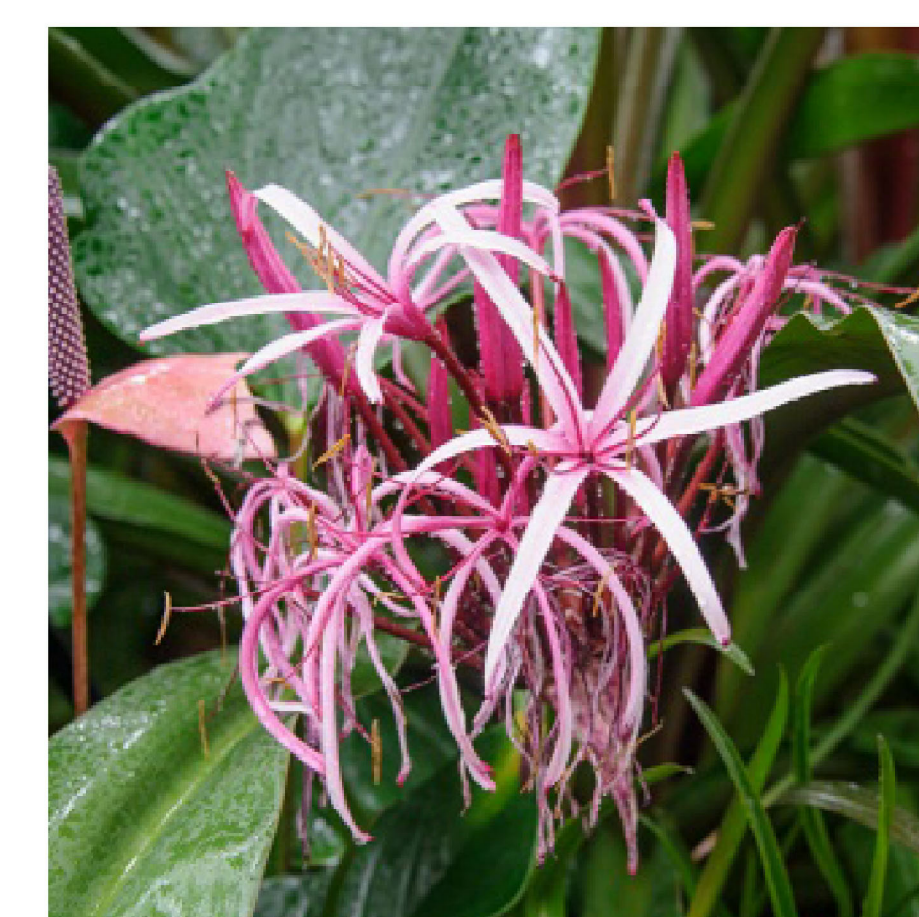

queen emma crinum lily

ALL REPORTS, PLANS, SPECIFICATIONS, COMPUTER FILES, FIELD DATA, NOTES AND OTHER DOCUMENTS AND INSTRUMENTS PREPARED BY THE CONSULTANT AS INSTRUMENTS OF SERVICE SHALL REMAIN THE PROPERTY OF THE CONSULTANT. THE CONSULTANT SHALL BE RESPONSIBLE FOR THE PROTECTION, SECURITY, STORAGE, TRANSPORTATION AND DELIVERY OF INSTRUMENTS OF SERVICE. INSTRUMENTS OF SERVICE SHALL NOT BE REPRODUCED OR COPIED WITHOUT THE WRITTEN PERMISSION OF THE CONSULTANT. INDIVIDUALS ARE NOT TO BE HELD RESPONSIBLE FOR NEGLIGENCE.

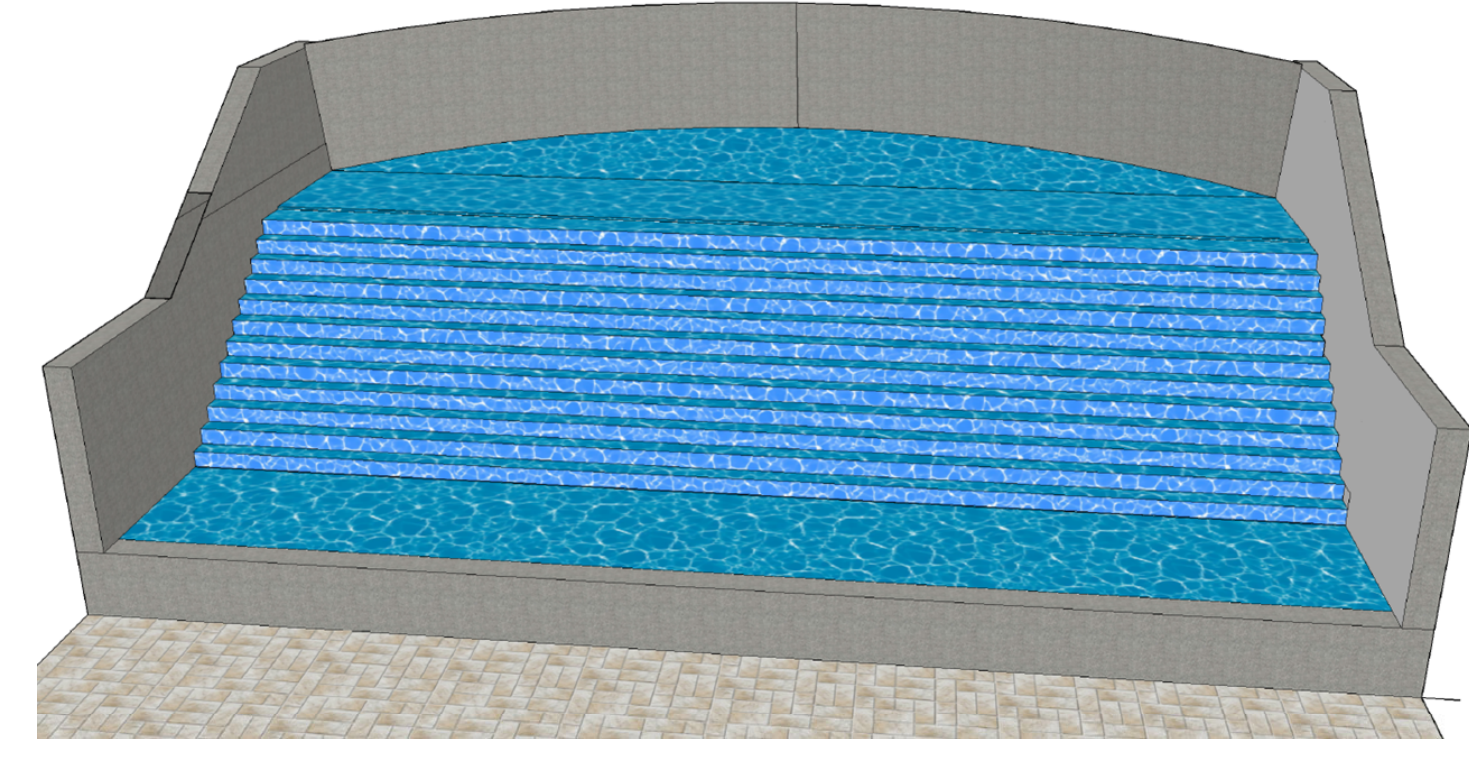
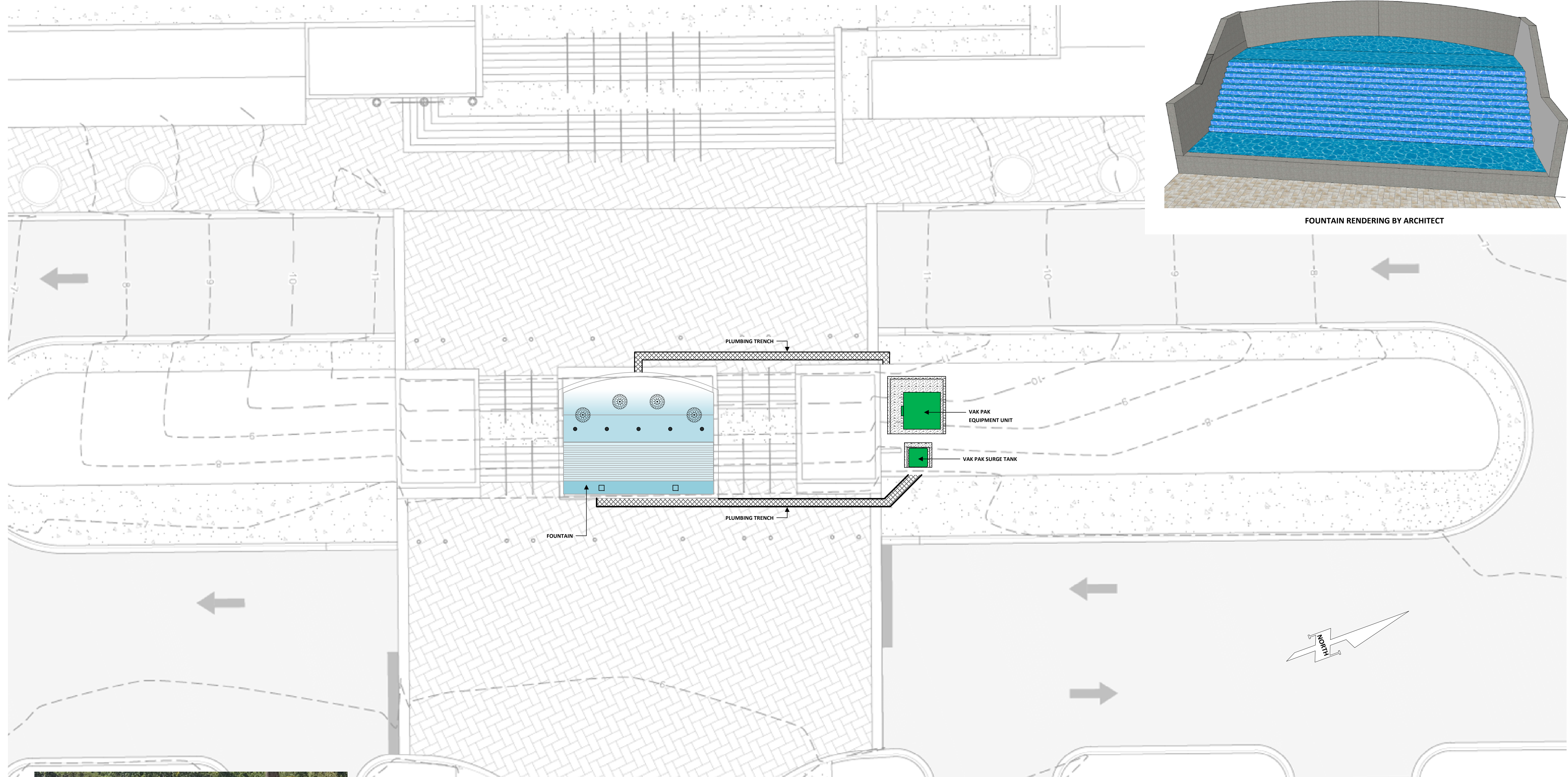

FOUNTAIN RENDERING BY ARCHITECT

WE ENGINEERING, LLC
 -- Certificate of Authorization #30719 --
 -- 9242 Zircore Lane --
 -- Land O Lakes, FL 34638 --



EXTERIOR ACCESSIBILITY FOR
**DESTIN FORT WALTON BEACH
 CONVENTION CENTER**
 1250 Miracle Strip Parkway SE,
 Fort Walton Beach, FL 32548

Sheet Title
**Entry Fountain
 Site Plan**

Drawing Release Date(s):
 2020, June 18

PN - Y20-0001PP
 DAG PN - 17057b
 Design - N.Eckhardt
 Checked - J.Gay
 Date - June 2020
 Scale: 1:10

Drawing #
C1.0
 1 of 3



GREEN VAK PAK EQUIPMENT UNIT

SAMPLE PHOTOS



GREEN VAK PAK SURGE TANK

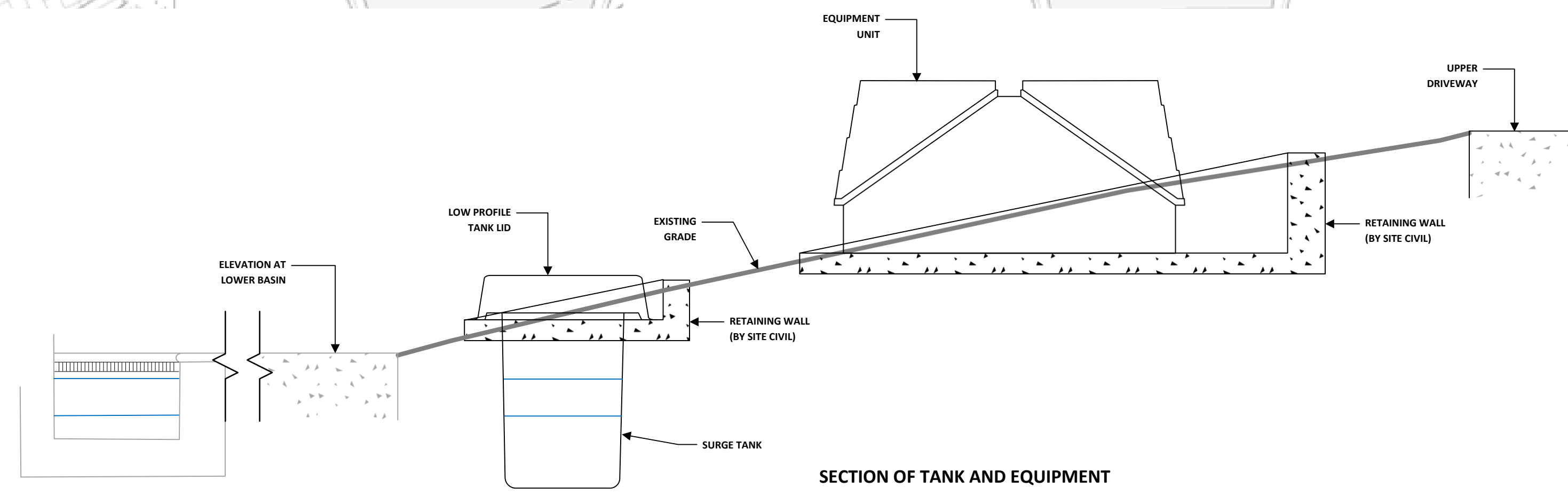

SECTION OF TANK AND EQUIPMENT

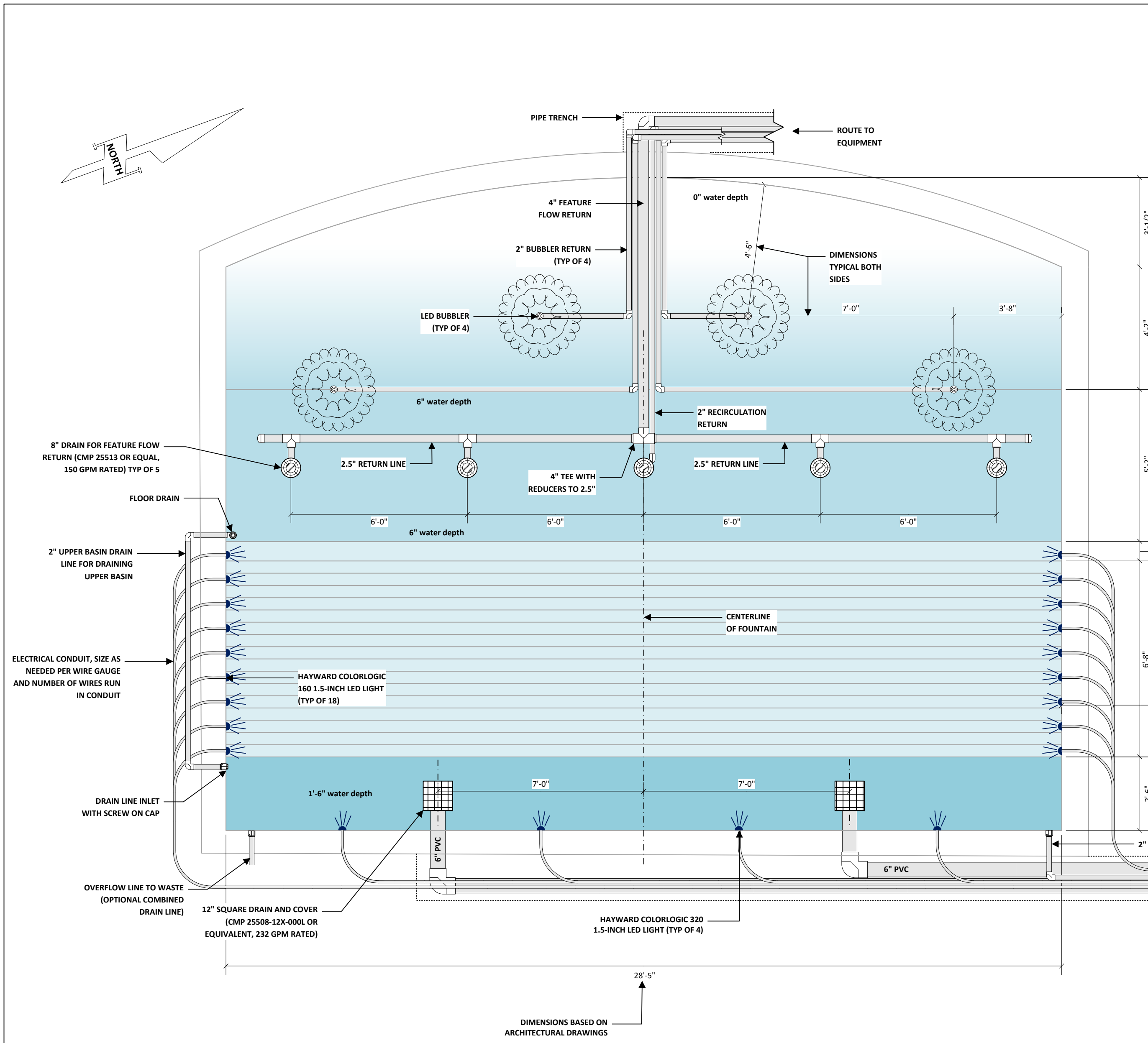

- SITE NOTES:**
1. SITE BACKGROUND BASED ON DEVELOPMENT DESIGN BY OTHERS. REFER TO ARCHITECTURAL DRAWINGS AND DEMOLITION DRAWINGS FOR ADDITIONAL INFORMATION.
 2. PLUMBING SHOWN IS SCHEMATIC ONLY, ROUTE PIPES IN TRENCHES MAKING FIELD ADJUSTMENTS AS NEEDED. PIPE SIZES SHOWN ARE MINIMUM FOR BALANCED HYDRAULICS.
 3. ELECTRICAL CONDUITS TO BE RUN IN THE PLUMBING TRENCH TO THE CONTROL PANEL.
 4. ALL PIPING AND FITTINGS TO BE NSF-PW APPROVED.
 5. ALL MOTORS AND RECEPTACLES TO BE PROTECTED BY GFCI BREAKERS AS REQUIRED BY NEC. ALL ELECTRICAL WIRING TO BE IN COMPLIANCE WITH THE NEC ELECTRICAL CODES. CHEMICAL FEED EQUIPMENT TO BE INTERLOCKED WITH THE RECIRCULATION PUMP.
 6. ALL CONSTRUCTION TO COMPLY WITH THE LATEST EDITION OF THE FLORIDA BUILDING CODE.

- EQUIPMENT UNIT TO INCLUDE:**
- ELECTRICAL PANEL 200A, 1 PHASE, 230V,
 - RECIRCULATION PUMP – HAYWARD 1.5HP, 69 GPM @ 60 FT TDH, SP3010X15
 - PRESSURE CARTRIDGE FILTER – HAYWARD C2030 225 SQ. FT.
 - FEATURE PUMP – SPECK 5HP, 95-IX, 350 GPM @35 FT TDH
 - PUMP TIMER
 - EROSION CHLORINE FEEDER – HAYWARD CL200 WITH CHECK VALVE AND SOLENOID
 - GFCI RECEPTACLE
 - VACUUM GAUGE (ONE PER PUMP)
 - PRESSURE GAUGE (ONE PER PUMP AND ONE ON FILTER)
 - EXHAUST VENT
 - MAINTENANCE LIGHT (LED)
 - ALL PIPING TO BE NSF-PW APPROVED
 - ALL ELECTRICAL WIRING TO BE IN COMPLIANCE WITH NEC ELECTRICAL
 - PUMPS TO BE PROTECTED BY GFCI BREAKERS AS REQUIRED BY NEC
 - OMNIOLOGIC LIGHT CONTROLLER WITH ADDITIONAL RELAYS TO CONTROL ALL FOUNTAIN LIGHTS AND BUBBLER LIGHTS.

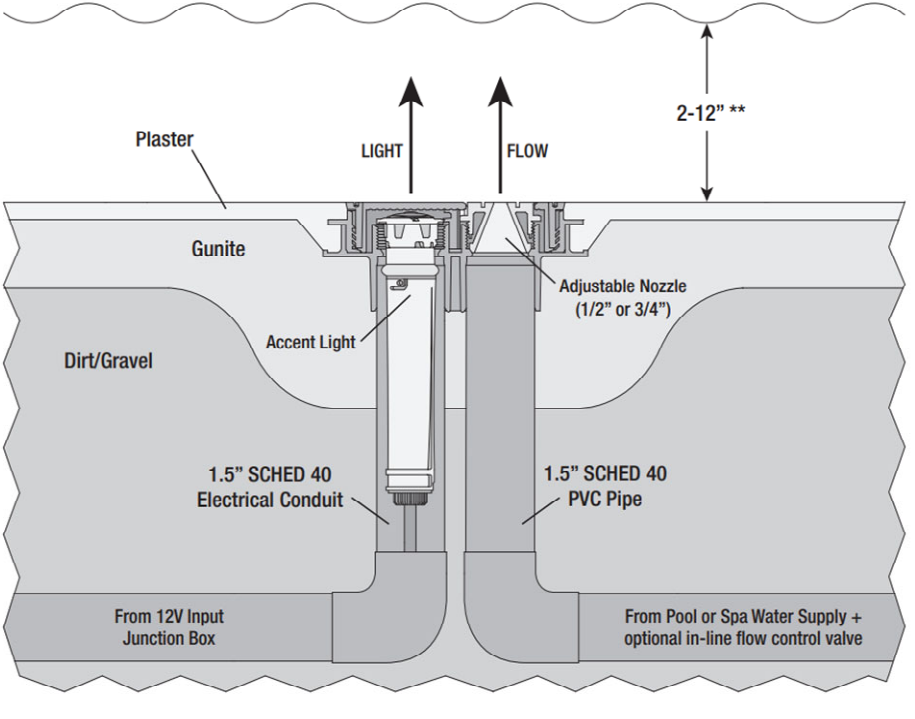
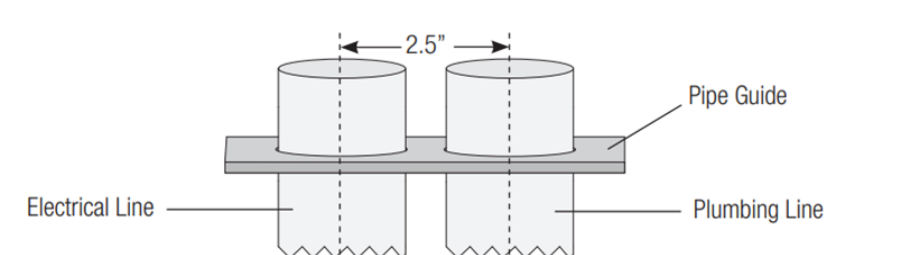
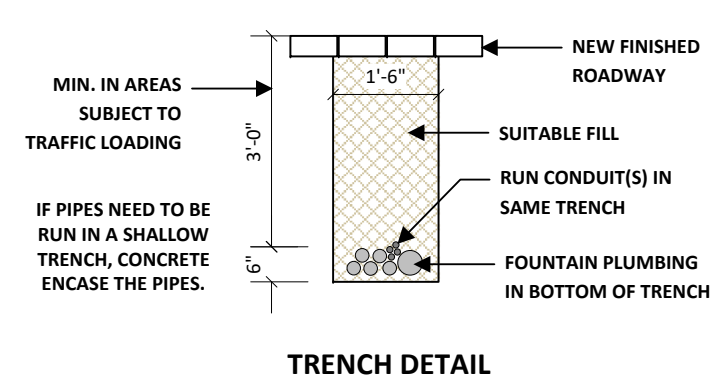
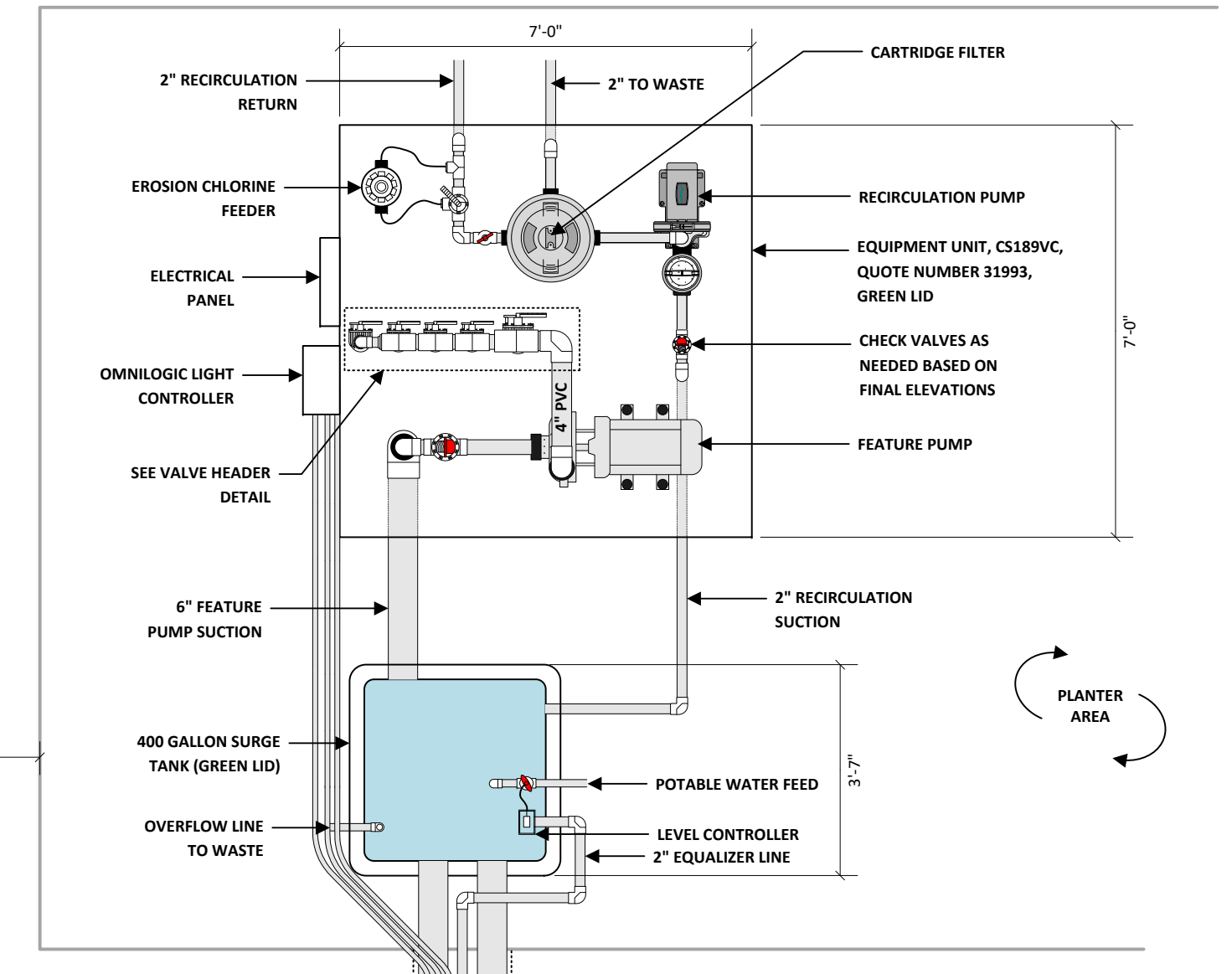
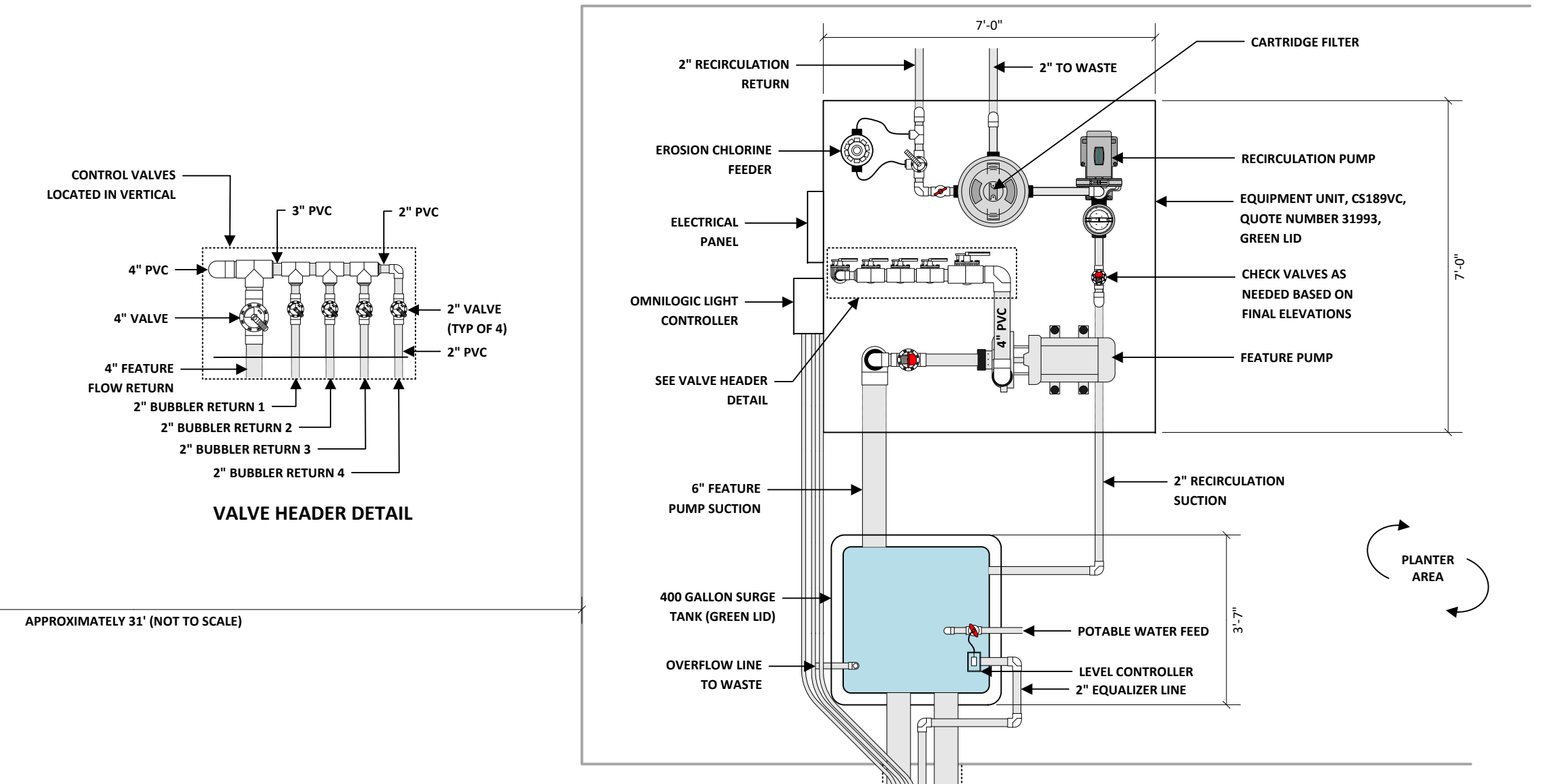

HAYWARD LED BUBBLER AND LIGHT DETAILS SHOWN FOR COORDINATION OF STRUCTURE PENETRATIONS. INSTALLER TO REFER TO MANUFACTURER'S PRODUCT MANUAL FOR INSTALLATION DETAILS.

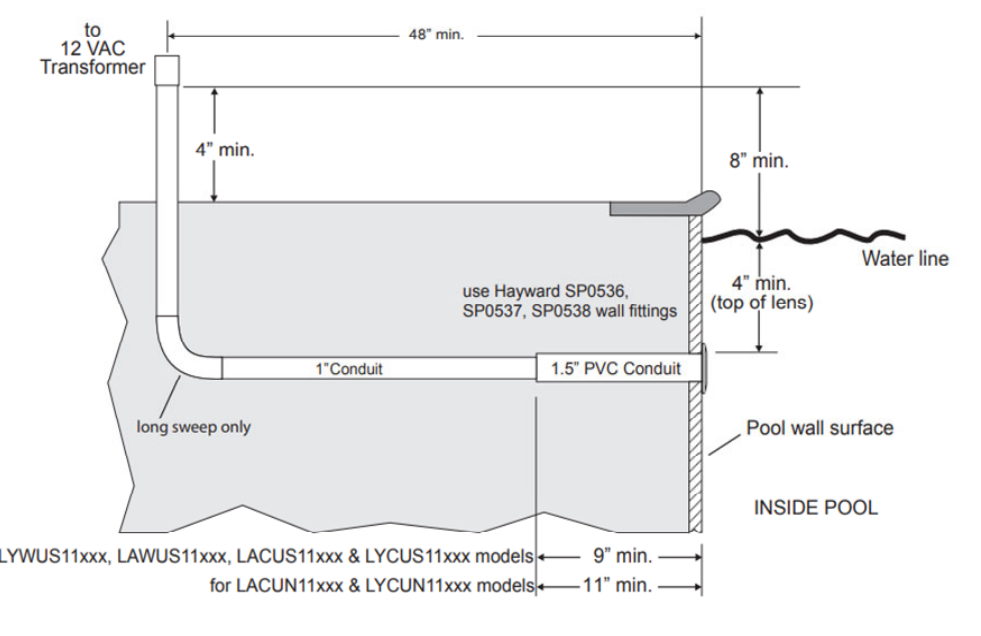

HAYWARD LED LIGHT DETAIL COLORLOGIC 160 & 320

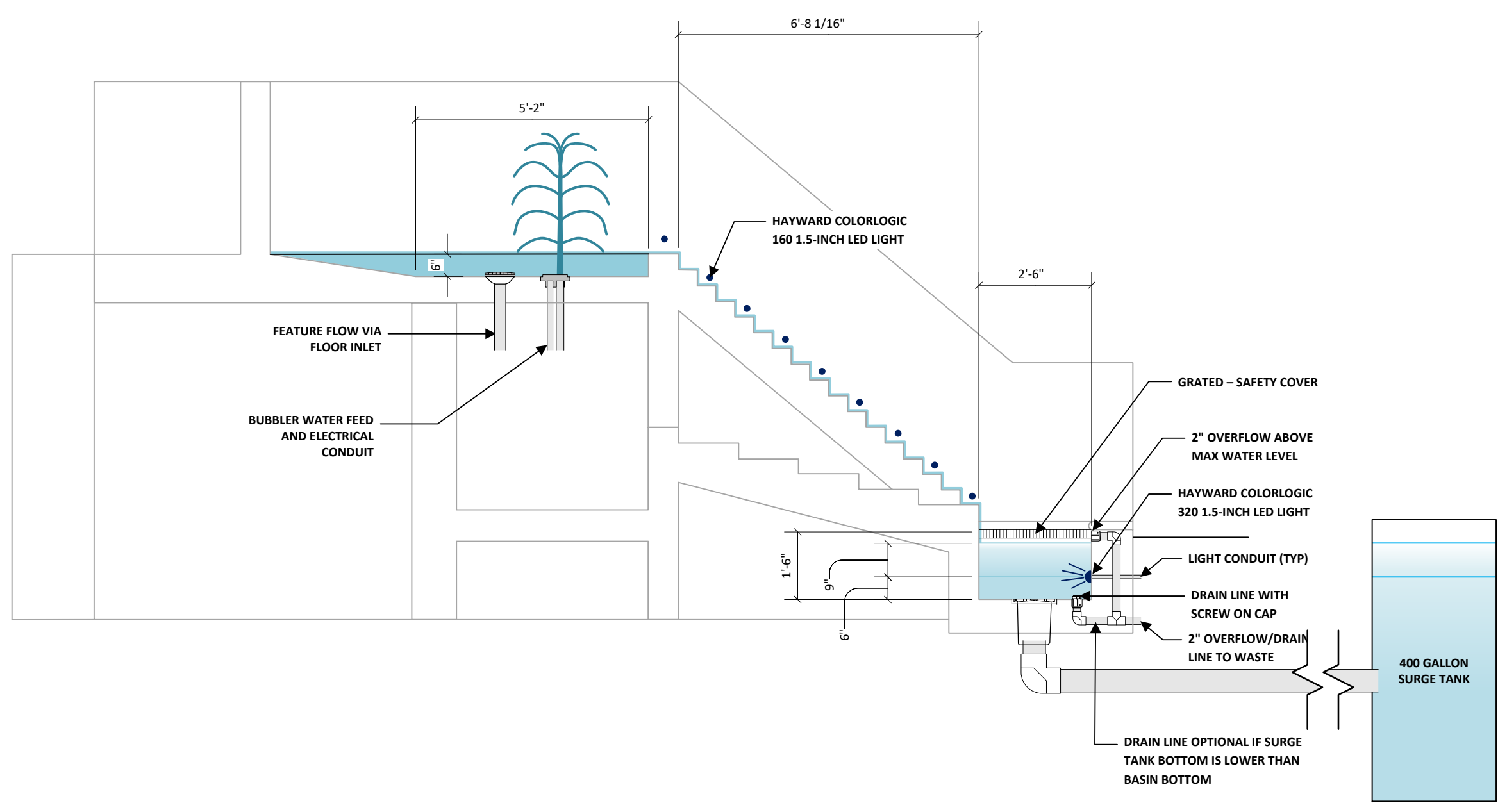

Nicholas W. Eckhardt, P.E.
 FL No. 19914
 Rec. No. 12/16/20
 Nel@weengineering.com

WE ENGINEERING, LLC
 -- Certificate of Authorization #30719 --
 -- 9242 Zircore Lane --
 -- Land O Lakes, FL 34638 --



EXTERIOR ACCESSIBILITY FOR
DESTIN FORT WALTON BEACH CONVENTION CENTER
 1250 Miracle Strip Parkway SE,
 Fort Walton Beach, FL 32548

Sheet Title
ENTRY FOUNTAIN HYDRAULICS

Drawing Release Date(s):
 2020, June 18

PN – Y20-0001PP
 DAG PN – 17057b
 Design – N.Eckhardt
 Checked – J.Gay
 Date – June 2020
 Scale: 3/8" = 1'-0"

Drawing #
C1.1
 2 of 3

NOTES:

- ALL PIPING "NSF-PW" APPROVED / ALL ELECTRICAL WIRING IN COMPLIANCE WITH NEC ELECTRICAL INTERLOCK OF ELECTRICAL FEED EQUIPMENT WITH RECIRCULATION PUMP. HYDRAULIC INTERLOCK OF EROSION FEED EQUIPMENT WITH RECIRCULATION PUMP. FLOW PROPORTIONING VALVES WHERE REQUIRED: 3" AND UNDER - DIVERTER VALVE; 4" AND ABOVE - BUTTERFLY VALVE
- ALL MOTORS AND RECEPTACLES ARE PROTECTED BY GFCI BREAKERS AS REQUIRED BY N.E.C.
- COMPLIES WITH THE 6TH EDITION OF THE FLORIDA BUILDING CODE.

INFORMATION THIS SHEET HAS BEEN PROVIDED BY VAK PAK SPECIFICALLY FOR THE DESTIN FORT WALTON BEACH CONVENTION CENTER. REFER TO VAK PAK NUMBER 31993 FOR ORDERING.

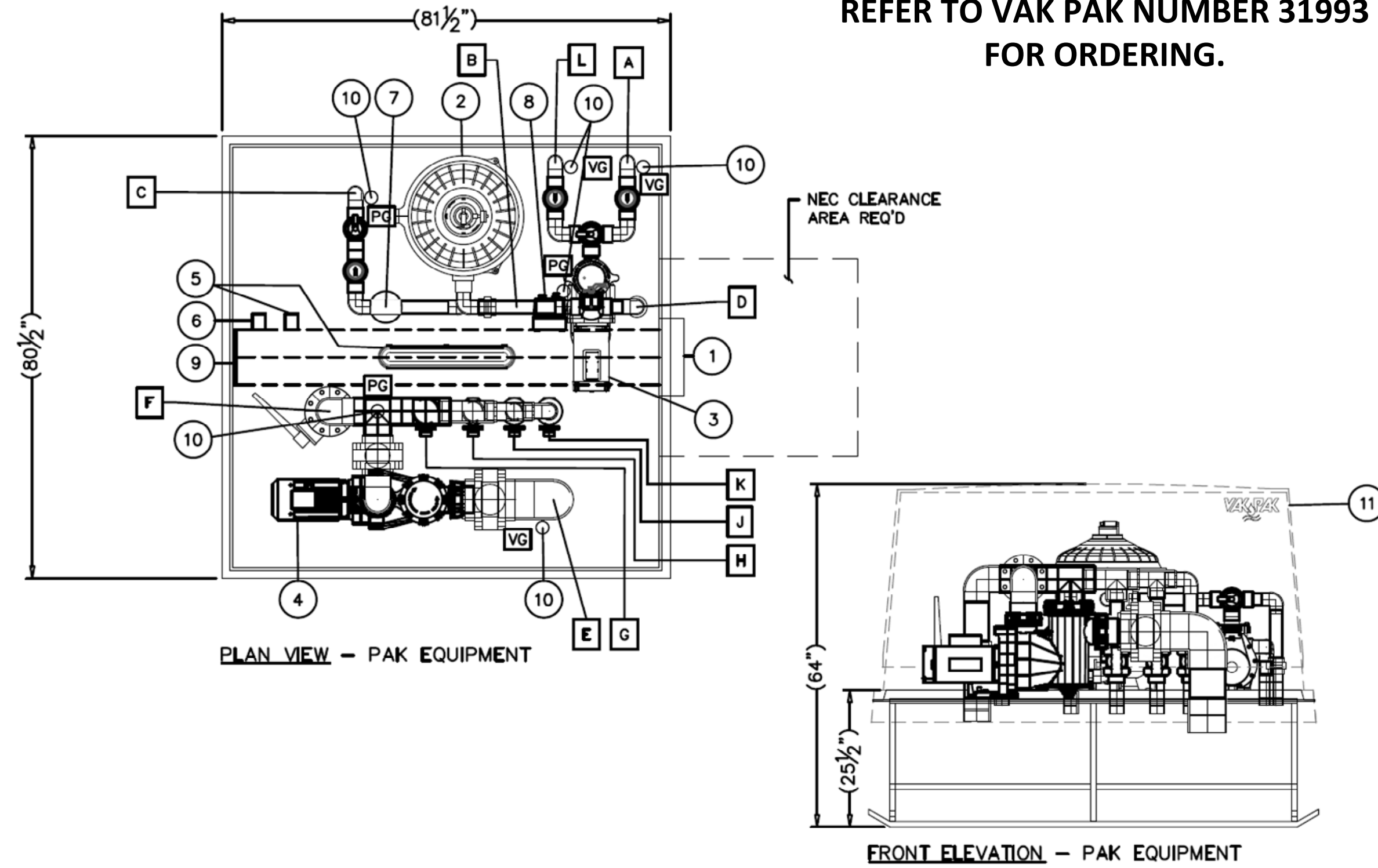

EQUIPMENT LIST	
CS189VC-C, 700 GALLONS, 50 GPM @ 60 TDH, IN .2 HRS, 225 SQ.FT TOTAL	
1	HAYWARD OMNILOGIC MAIN BREAKER ELECTRIC PANEL, 200A 1φ-120/240V
2	HAYWARD C2030 CARTRIDGE FILTER, 225 SQ.FT, 0.2 GPM FILTER RATE
3	1.5 HP - HAYWARD SP3010X15 RECIRC. PUMP, 69 GPM @ 60 TDH, 1φ-230V
4	5 HP - SPECK 95-IX FEATURE PUMP, 1φ-230V
5	LED SERVICE LIGHT, MINIMAL 30 FT CANDLES, MINIMUM 351 LM/FT, W/ SPST SWITCH
6	RECEPTACLE - GFCI
7	CL FEEDER, HAYWARD CL200 IN-LINE CHLORINATOR
8	MOTOR STARTER FOR RECIRC. PUMP, 1φ-230V, MOTOR STARTER PROVIDED BY REQUEST
9	EXHAUST VENT
10	(3) PRESSURE GAUGE, 0# TO 60#, (3) VACUUM GAUGE, 0# TO 30#
11	CB617, CT700LPS, GREEN CABINET

VALVES AND PIPE CONNECTION SIZES		
A	RECIRC. SUCTION	2"
B	PUMP TO FILTER	2"
C	RETURN	2"
D	WASTE	2"
E	FEATURE SUCTION	6"
F	FEATURE DISCHARGE A	4"
G	FEATURE DISCHARGE B	2"
H	FEATURE DISCHARGE C	2"
J	FEATURE DISCHARGE D	2"
K	FEATURE DISCHARGE E	2"
L	TANK DRAIN	2"

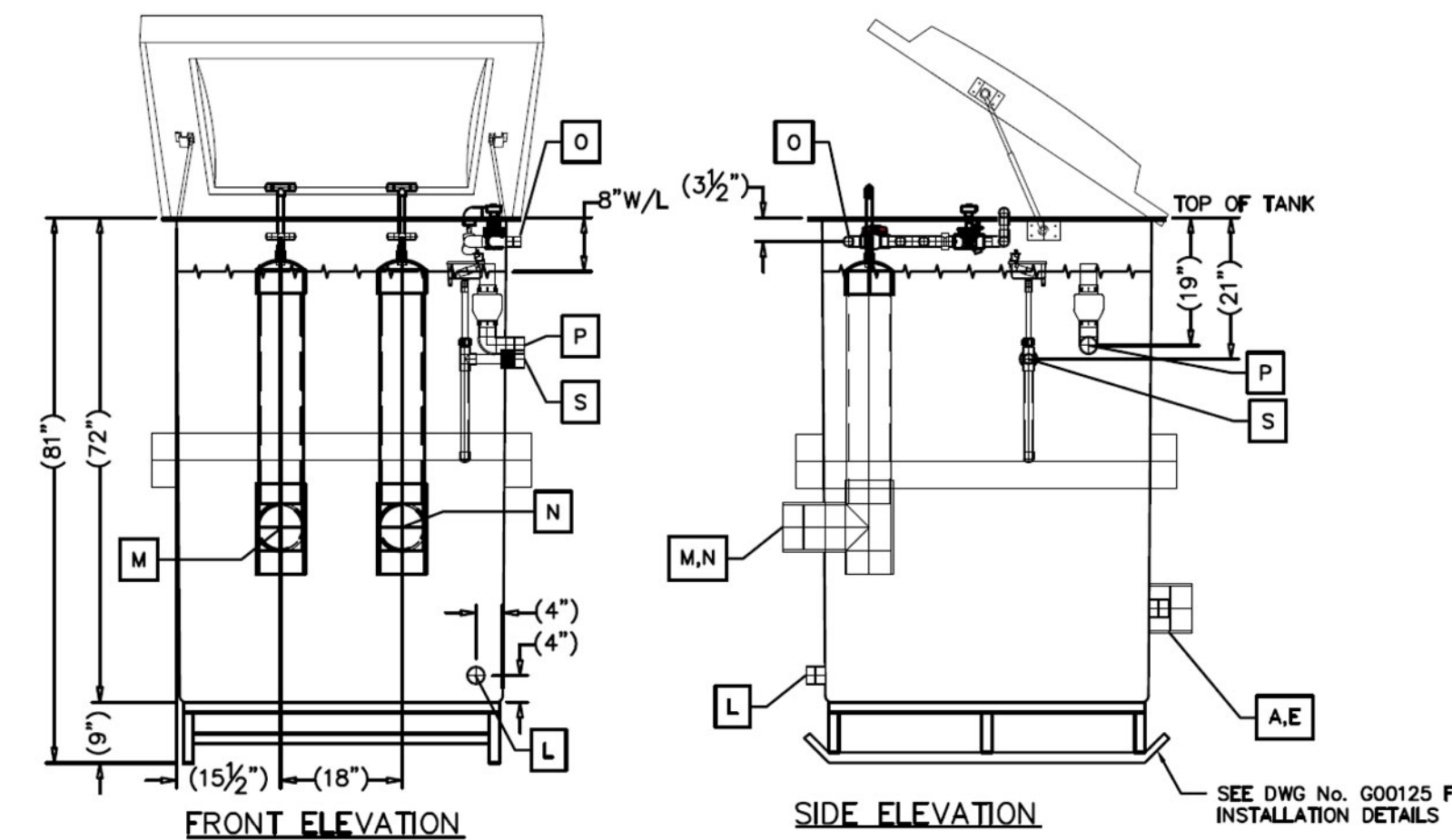
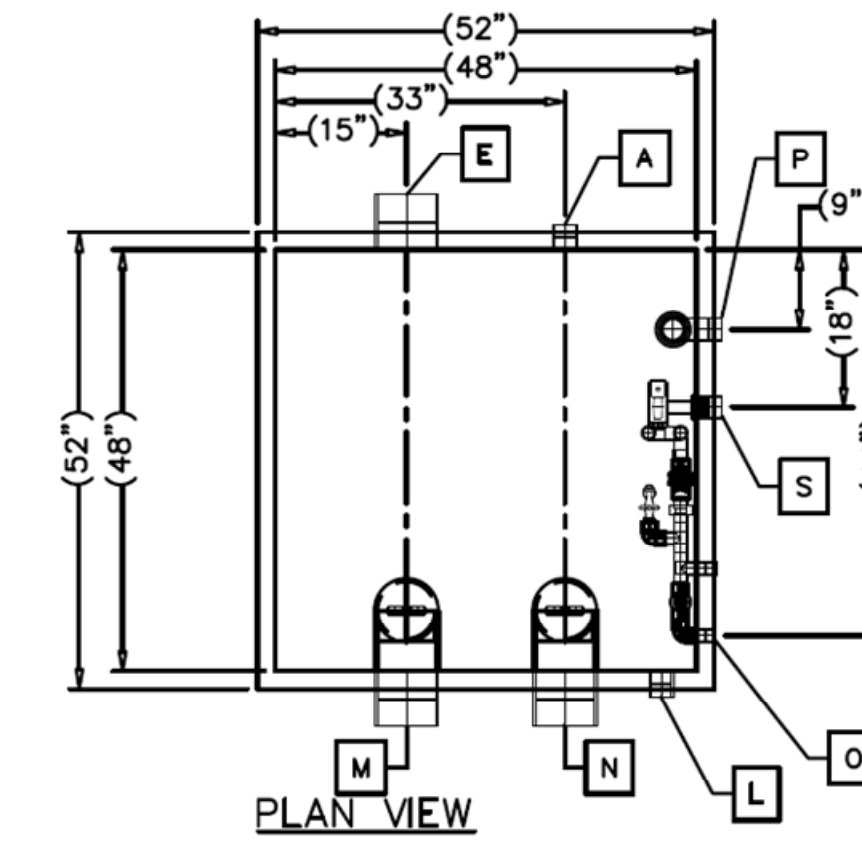

GENERAL NOTE:
1. TANK EQUIPPED WITH QTY-2 SUCTION PORTS.

#	MFG	PART #	DESCRIPTION
1	HAYWARD	HLLBASE	OMNILOGIC MAIN BREAKER PANEL, 12SP, 200A - 1φ-120/240V
3	HAYWARD	SP3010X15 (SUPER II)	1.5 HP RECIRCULATION PUMP, 1φ-230V
4	SPECK	IG274-1500F-000 (95-IX)	5 HP FEATURE PUMP, 1φ-230V
5	SBL	VTS2D-50K30M	LED SERVICE LIGHT, 1φ-120V, W/ SPST SWITCH
6	LEVITON	5320	RECEPTACLE W/ EXTRA-DUTY WEATHER-PROOF COVER, 1φ-120V
8	C3 OR EQUAL	E620-MXN11-58-GR 102-03-W2	5 HP MOTOR STARTER FOR RECIRC. PUMP, 1φ-230V, STARTER PROVIDED BY REQUEST

CONDUCTORS				REMARKS
PHASE	NEUTRAL	GROUND	CONDUIT	
Δ				PANEL FEED BY OTHERS
Δ	2 - #12		1/2"	TYPE LFNC-B UL SEALTITE
Δ		1 - #12	1/2"	TYPE LFNC-B UL SEALTITE
Δ	1 - #12	1 - #12	1/2"	TYPE LFNC-B UL SEALTITE
Δ	1 - #14	1 - #14	1/2"	TYPE LFNC-B UL SEALTITE
Δ	1 - #14	1 - #14	1/2"	TYPE SJOOW-3C
Δ	INDICATES WIRE AND CONDUIT INSTALLED BY OTHERS			

PANEL SCHEDULE					
120/240V, 1 PHASE, 3 WIRE, NEMA 3R, 12SP, 200A MBR					
CIR.	POLES	TRIP	LOAD	AMPS	DEMAND FACTOR 1.25
1	2	20A-GFCI	RECIRC PUMP	15.0	18.8
2	1	15A-GFCI	LOGIC CIRCUIT POWER	5.0	6.3
3	1	15A-GFCI	SERVICE LIGHT	1.5	1.9
5	2	30A-GFCI	FEATURE PUMP	23.0	28.8
6	1	15A	SERVICE OUTLET - GFCI (12 AMP MAX)	12.0	15.0
TOTAL LOAD				56.5	70.6

ADDITIONAL CIRCUITS AND BREAKERS TO BE INSTALLED FOR THE LIGHTS

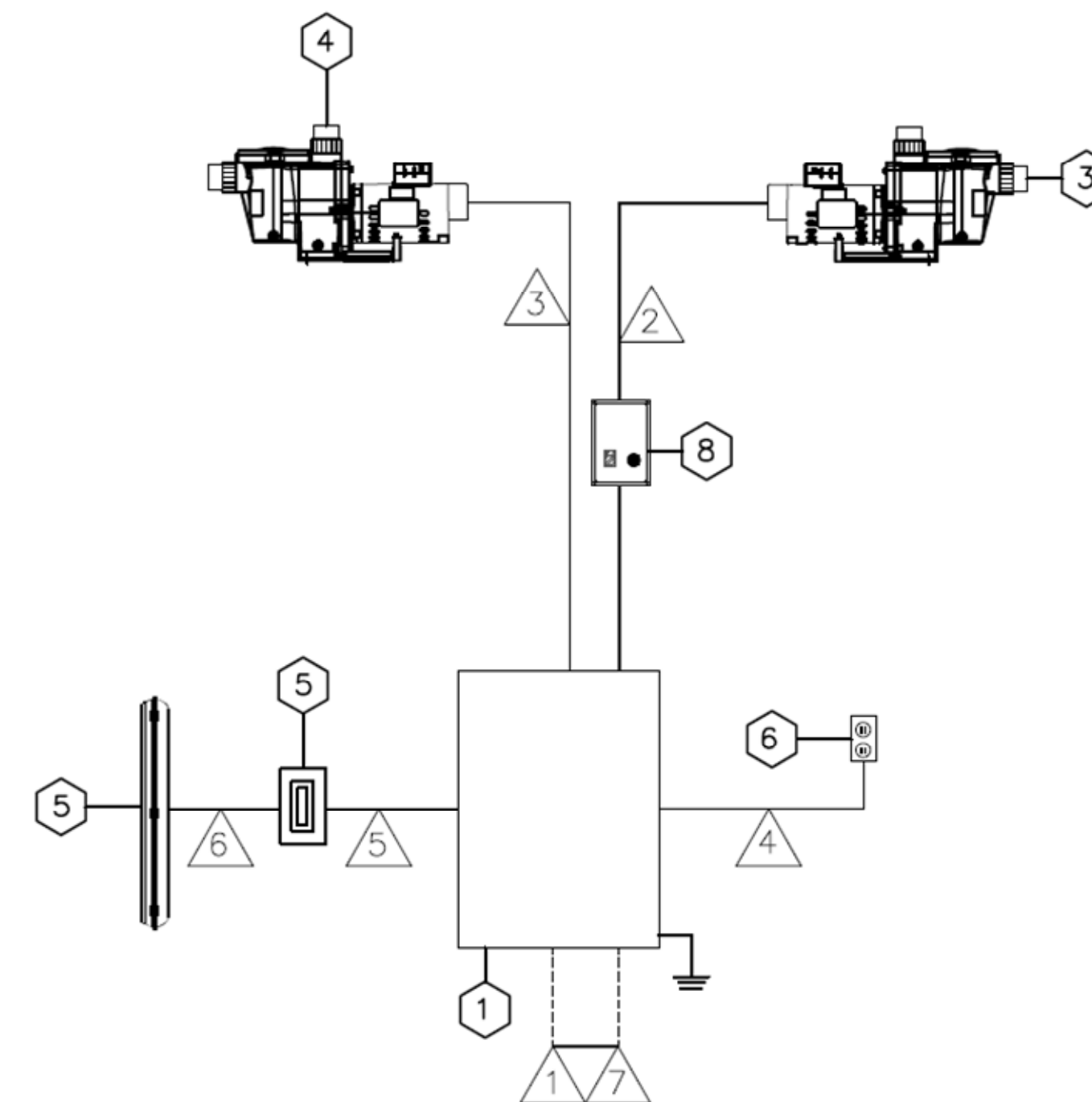

GENERAL SHEET NOTES

- THE CONTRACTOR SHALL SUBMIT SHOP DRAWINGS TO EOR/AOR/LA FOR REVIEW AND APPROVAL
- CONCRETE TANK ANCHOR - GRADE M25
 - ANCHOR REINFORCING - GRADE 60, #4 @ 12" OCEW TOP & BOTTOM.
 - VISQUEEN VAPOR BARRIER.
 - CRUSHED ROCK/STONE.
 - COMPACTED SOIL.

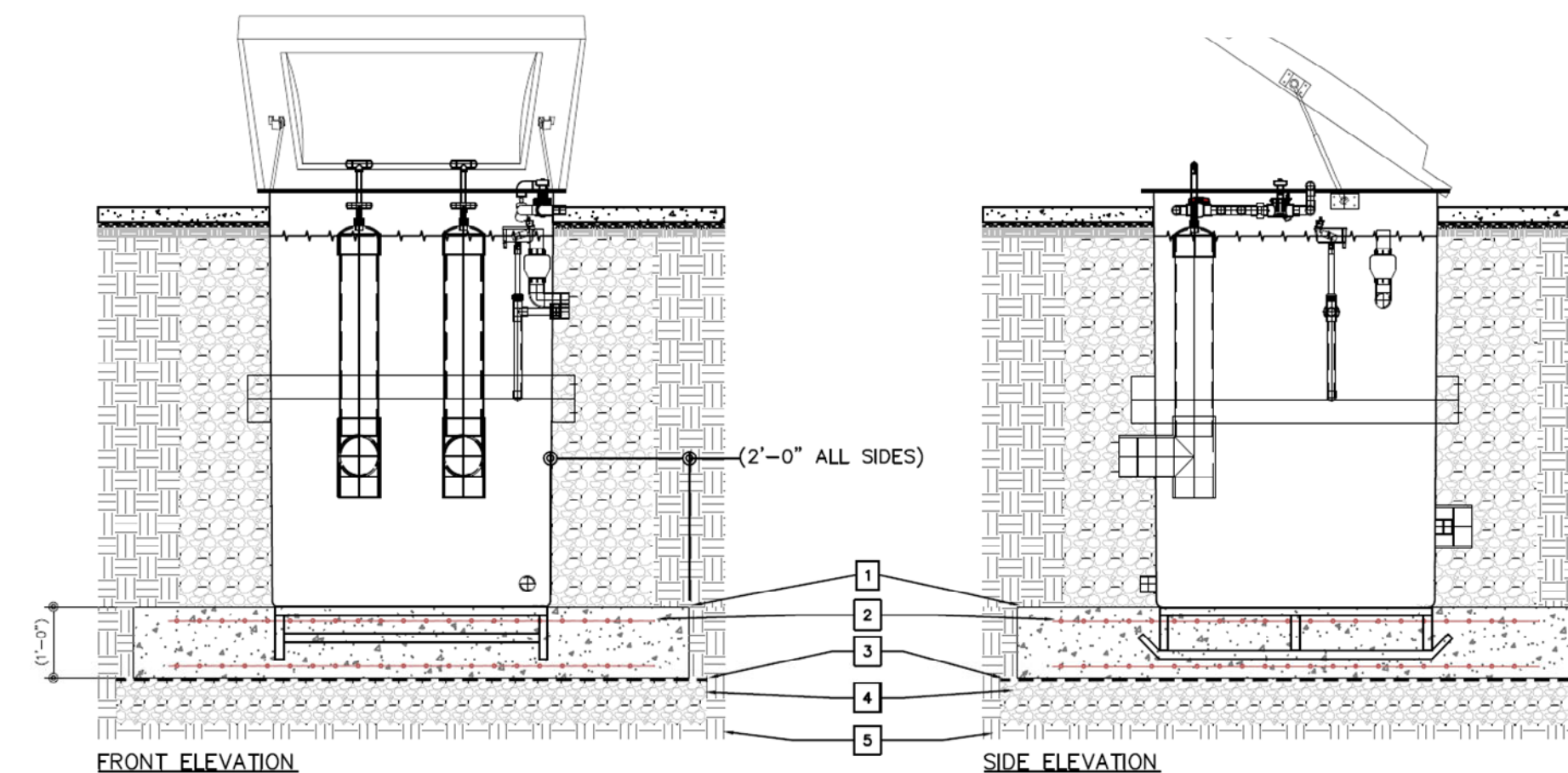

VALVES AND PIPE CONNECTION SIZES		
A	RECIRC. SUCTION	2"
E	FEATURE SUCTION	6"
L	TANK DRAIN	2"
M	MAIN	6"
N	SKIMMER/GUTTER	6"
O	FRESH WATER	1"
P	OVERFLOW	2"
S	STATIC LINE	2"

Nicholas W. Eckhardt, P.E.
FL No. 19914
Res. No. 160620
Nee@weengineering.com
WE ENGINEERING, LLC
Certificate of Authorization #30719
9242 Zircon Lane
Land O Lakes, FL 34638

PANAMA POOLS & SPAS

EXTERIOR ACCESSIBILITY FOR
DESTIN FORT WALTON BEACH CONVENTION CENTER
1250 Miracle Strip Parkway SE,
Fort Walton Beach, FL 32548

Sheet Title

EQUIPMENT UNIT AND TANK DETAILS

Drawing Release Date(s):
2020, June 18

PN - Y20-0001PP
DAG PN - 17057b
Design - N.Eckhardt
Checked - J.Gay
Date - June 2020
Scale: NO SCALE

Drawing #

C1.2



AGREEMENT BETWEEN OKALOOSA COUNTY, FLORIDA

AND

CONTRACT ID

THIS AGREEMENT (hereinafter referred to as the “Agreement”) is made this _____, day of _____, 20_____, by and between Okaloosa County, a political subdivision of the state of Florida, (hereinafter referred to as the “County”), with a mailing address of 1250 N. Eglin Parkway, Suite 100, Shalimar, Florida, 32579, and _____, a _____ authorized to do business in the State of Florida (hereinafter referred to as “Contractor”) whose Federal I.D. # is _____.

RECITALS

WHEREAS, the County is in need of a contractor to provide _____ (“Services”); and

WHEREAS, pursuant to the Okaloosa County Purchasing Manual, the County issued an _____ to competitively procure the Services and received responses to perform these Services. A copy of the procurement and Contractor’s responsive to the procurement is included as Attachment “A”; and

WHEREAS, Contractor is a certified and insured entity with the necessary experience to provide the desired Services; and

WHEREAS, the County wishes to enter into this Agreement with Contractor to provide the Services to the County for an amount of _____ Dollars (\$ _____), as further detailed below.

NOW THEREFORE, in consideration of the promises and the mutual covenants herein, the parties agree as follows:

1. Recitals and Attachments. The Recitals set forth above are hereby incorporated into this Agreement and made part hereof for reference. The following documents are attached to this Agreement and are incorporated herein.

- Attachment “A” – Procurement _____ and Contractor’s Response;
- Attachment “B” – Insurance Requirements;
- Attachment “C” – Title VI list of pertinent nondiscrimination acts and authorities;
- Attachment “D” – Scrutinized Companies Certification;



2. Services. Contractor agrees to perform the following services,

_____.

The Services to be provided are further detailed in the Contractor's proposal attached as Attachment "A" and incorporated herein by reference. The Services shall be performed by Contractor to the full satisfaction of the County. Contractor agrees to have a qualified representative to audit and inspect the Services provided on a regular basis to ensure all Services are being performed in accordance with the County's needs and pursuant to the terms of this Agreement and shall report to the County accordingly. Contractor agrees to immediately inform the County via telephone and in writing of any problems that could cause damage to the County. Contractor will require its employees to perform their work in a manner befitting the type and scope of work to be performed.

3. Term and Renewal. The term of this Agreement shall begin _____, and shall continue for a period of _____ (____) _____ days from the date of full execution of this Agreement, subject to the County's ability to terminate in accordance with Section 7 of this Agreement. The terms of Section 20 entitled "Indemnification and Waiver of Liability" shall survive termination of this Agreement.

This agreement may not be renewed; or

This agreement may be renewed upon mutual written agreement of the parties for a period of up to _____, _____ renewals.

4. Compensation. The Contractor agrees to provide the Services to the County, including materials and labor, in a total amount of _____ Dollars (\$ _____).

a. Contractor shall submit an invoice to the County upon _____. The invoice shall indicate that all services have been completed for that invoice period. In addition, Contractor agrees to provide the County with any additional documentation requested to process the invoices.

b. Disbursement. Check one:

There are no reimbursable expenses associated with this Agreement.

The following are reimbursable expenses associated with this Agreement:

--



- c. **Payment Schedule.** Invoices received from the Contractor pursuant to this Agreement will be reviewed by the initiating County Department. Payment will be disbursed as set forth above. If services have been rendered in conformity with the Agreement, the invoice will be sent to the Finance Department for payment. Invoices must reference the contract number assigned by the County after execution of this Agreement. Invoices will be paid in accordance with the State of Florida Local Government Prompt Payment Act.
- d. **Availability of Funds.** The County's performance and obligation to pay under this Agreement is contingent upon annual appropriation for its purpose by the County Commission.

Contractor shall make no other charges to the County for supplies, labor, taxes, licenses, permits, overhead or any other expenses or costs unless any such expenses or cost is incurred by Contractor with the prior written approval of the County. If the County disputes any charges on the invoices, it may make payment of the uncontested amounts and withhold payment on the contested amounts until they are resolved by agreement with the Contractor. Contractor shall not pledge the County's credit or make it a guarantor of payment or surety for any contract, debt, obligation, judgment, lien, or any form of indebtedness. The Contractor further warrants and represents that it has no obligation or indebtedness that would impair its ability to fulfill the terms of this Agreement.

5. Ownership of Documents and Equipment. All documents prepared by the Contractor pursuant to this Agreement and related Services to this Agreement are intended and represented for the ownership of the County only. Any other use by Contractor or other parties shall be approved in writing by the County. If requested, Contractor shall deliver the documents to the County within fifteen (15) calendar days.

6. Insurance. Contractor shall, at its sole cost and expense, during the period of any work being performed under this Agreement, procure and maintain the minimum insurance coverage required as set forth in Attachment "B" attached hereto and incorporated herein, to protect the County and Contractor against all loss, claims, damages and liabilities caused by Contractor, its agents, or employees.

7. Termination and Remedies for Breach.

- a. If, through any cause within its reasonable control, the Contractor shall fail to fulfill in a timely manner or otherwise violate any of the covenants, agreements or stipulations material to this Agreement, the County shall have the right to terminate the Services then remaining to be performed. Prior to the exercise of its option to terminate for cause, the County shall notify the Contractor of its violation of the particular terms of the Agreement and grant Contractor _____ (_____) days to cure such default. If the default remains uncured after _____ (_____) days the County may terminate this Agreement, and the County shall receive a refund from the Contractor in an amount equal to the actual cost of a third party to cure such failure. If Contractor fails, refuses or is unable



to perform any term of this Agreement, County shall pay for services rendered as of the date of termination.

- i. In the event of termination, all finished and unfinished documents, data and other work product prepared by Contractor (and sub-Contractor (s)) shall be delivered to the County and the County shall compensate the Contractor for all Services satisfactorily performed prior to the date of termination, as provided in Section 4 herein.
 - ii. Notwithstanding the foregoing, the Contractor shall not be relieved of liability to the County for damages sustained by it by virtue of a breach of the Agreement by Contractor and the County may reasonably withhold payment to Contractor for the purposes of set-off until such time as the exact amount of damages due the County from the Contractor is determined.
- b. Termination for Convenience of County. The County may, for its convenience and without cause immediately terminate the Services then remaining to be performed at any time by giving written notice. The terms of Section 7 Paragraphs a(i) and a(ii) above shall be applicable hereunder.
 - c. Termination for Insolvency. The County also reserves the right to terminate the remaining Services to be performed in the event the Contractor is placed either in voluntary or involuntary bankruptcy or makes any assignment for the benefit of creditors.
 - d. Termination for failure to adhere to the Public Records Law. Failure of the Contractor to adhere to the requirements of Chapter 119 of the Florida Statutes and Section 9 below, may result in immediate termination of this Agreement.

8. Governing Law, Venue and Waiver of Jury Trial. This Agreement shall be interpreted and construed in accordance with and governed by the laws of the State of Florida. All parties agree and accept that jurisdiction of any dispute or controversy arising out of this Agreement, and any action involving the enforcement or interpretation of any rights hereunder shall be brought exclusively in the First Judicial Circuit in and for Okaloosa County, Florida, and venue for litigation arising out of this Agreement shall be exclusively in such state courts, forsaking any other jurisdiction which either party may claim by virtue of its residency or other jurisdictional device. In the event it becomes necessary for the County to file a lawsuit to enforce any term or provision under this Agreement, then the County shall be entitled to its costs and attorney's fees at the pretrial, trial and appellate levels. BY ENTERING INTO THIS AGREEMENT, CONTRACTOR AND COUNTY HEREBY EXPRESSLY WAIVE ANY RIGHTS EITHER PARTY MAY HAVE TO A TRIAL BY JURY OF ANY CIVIL LITIGATION RELATED TO THIS AGREEMENT. Nothing in this Agreement is intended to serve as a waiver of sovereign immunity, or of any other immunity, defense, or privilege enjoyed by the County pursuant to Section 768.28, Florida Statutes.



9. Public Records. Any record created by either party in accordance with this Contract shall be retained and maintained in accordance with the public records law, Florida Statutes, Chapter 119. Contractor must comply with the public records laws, Florida Statute chapter 119, specifically Contractor must:

- a. Keep and maintain public records required by the County to perform the service.
- b. Upon request from the County's custodian of public records, provide the County with a copy of the requested records or allow the records to be inspected or copied within a reasonable time at a cost that does not exceed the cost provided in chapter 119 Florida Statutes or as otherwise provided by law.
- c. Ensure that public records that are exempt or confidential and exempt from public records disclosure requirements are not disclosed except as authorized by law for the duration of the contract term and following completion of the contract if the contractor does not transfer the records to the County.
- d. Upon completion of the contract, transfer, at no cost, to the County all public records in possession of the contractor or keep and maintain public records required by the County to perform the service. If the contractor transfers all public records to the public agency upon completion of the contract, the contractor shall destroy any duplicate public records that are exempt or confidential and exempt from public records disclosure requirements. If the contractor keeps and maintains public records upon completion of the contract, the contractor shall meet all applicable requirements for retaining the public records. All records stored electronically must be provided to the public agency, upon the request from the public agency's custodian of public records, in a format that is compatible with the information technology systems of the public agency.

IF THE CONTRACTOR HAS QUESTIONS REGARDING THE APPLICATION OF CHAPTER 119, FLORIDA STATUTES, TO THE CONTRACTOR'S DUTY TO PROVIDE PUBLIC RECORDS RELATING TO THIS CONTRACT, CONTACT THE CUSTODIAN OF PUBLIC RECORDS AT OKALOOSA COUNTY RISK MANAGEMENT DEPARTMENT 302 N. WILSON ST., CRESTVIEW, FL 32536 PHONE: (850) 689-5977 riskinfo@myokaloosa.com.

10. Audit. The County and/or its designee shall have the right from time to time at its sole expense to audit the compliance by the Contractor with the terms, conditions, obligations, limitations, restrictions, and requirements of this Contract and such right shall extend for a period of three (3) years after termination of this Contract.

11. Notices. All notices and other communications required or permitted to be given under this Agreement by either party to the other shall be in writing and shall be sent (except as otherwise



provided herein) (i) by certified mail, first class postage prepaid, return receipt requested, (ii) by guaranteed overnight delivery by a nationally recognized courier service, or (iii) by facsimile with confirmation receipt (with a copy simultaneously sent by certified mail, first class postage prepaid, return receipt requested or by overnight delivery by traditionally recognized courier service), addressed to such party as follows:

If to the County:		With a copy to: County Attorney Office 1250 N. Eglin Pkwy, Suite 100 Shalimar, FL 32579 (850) 224-4070
If to the Contractor:		

12. Assignment. Contractor shall not assign this Agreement or any part thereof, without the prior consent in writing of the County. If Contractor does, with approval, assign this Agreement or any part thereof, it shall require that its assignee be bound to it and to assume toward Contractor all of the obligations and responsibilities that Contractor has assumed toward the County.

13. Subcontracting. Contractor shall not subcontract any services or work to be provided to County without the prior written approval of the County's Representative. The County reserves the right to accept the use of a subcontractor or to reject the selection of a particular subcontractor and to inspect all facilities of any subcontractors in order to make a determination as to the capability of the subcontractor to perform properly under this Agreement. The County's acceptance of a subcontractor shall not be unreasonably withheld. The Contractor is encouraged to seek minority and women business enterprises for participation in subcontracting opportunities. Additionally, any subcontract entered into between the Contractor and subcontractor will need to be approved by the County prior to it being entered into and said agreement shall incorporate in all required terms in accordance with local, state and Federal regulations.

14. Civil Rights. The Contractor agrees to comply with pertinent statutes, Executive Orders and such rules as are promulgated to ensure that no person shall, on the grounds of race, creed, color, national origin, sex, age, or disability be excluded from participating in any activity conducted with or benefiting from Federal assistance. This provision binds the Contractor and subcontractors from the bid solicitation period through the completion of the contract. This provision is in addition to that required by Title VI of the Civil Rights Act of 1964.

15. Compliance with Nondiscrimination Requirements. During the performance of this Agreement, the Contractor, for itself, its assignees, and successors in interest, agrees as follows:



- a. Compliance with Regulations: The Contractor will comply with the Title VI List of Pertinent Nondiscrimination Acts and Authorities, as they may be amended from time to time, which are herein incorporated and attached hereto as Attachment “C”.
- b. Nondiscrimination: The Contractor, with regard to the work performed by it during the Agreement, will not discriminate on the grounds of race, color, or national origin in the selection and retention of subcontractors, including procurements of materials and leases of equipment. The Contractor will not participate directly or indirectly in the discrimination prohibited by the Nondiscrimination Acts and Authorities, including employment practices when the contract covers any activity, project, or program set forth in Appendix B of 49 CFR part 21.
- c. Solicitations for Subcontracts, including Procurements of Materials and Equipment: In all solicitations, either by competitive bidding or negotiation made by the Contractor for work to be performed under a subcontract, including procurements of materials, or leases of equipment, each potential subcontractor or supplier will be notified by the Contractor of the contractor’s obligations under this contract and the Nondiscrimination Acts and Authorities on the grounds of race, color, or national origin.
- d. Information and Reports: The Contractor will provide all information and reports required by the Acts, the Regulations, and directives issued pursuant thereto and will permit access to its books, records, accounts, other sources of information, and its facilities as may be determined by the County or other governmental entity to be pertinent to ascertain compliance with such Nondiscrimination Acts and Authorities and instructions. Where any information required of a contractor is in the exclusive possession of another who fails or refuses to furnish the information, the Contractor will so certify to the County or the other governmental entity, as appropriate, and will set forth what efforts it has made to obtain the information.
- e. Sanctions for Noncompliance: In the event of a Contractor’s noncompliance with the non-discrimination provisions of this contract, the County will impose such contract sanctions as it or another applicable state or federal governmental entity may determine to be appropriate, including, but not limited to:
 - a. Withholding payments to the Contractor under the Agreement until the Contractor complies; and/or
 - b. Cancelling, terminating, or suspending the Agreement, in whole or in part.
- f. Incorporation of Provisions: The Contractor will include the provisions of paragraphs one through six in every subcontract, including procurements of materials and leases of equipment, unless exempt by the Acts, the Regulations, and directives issued pursuant thereto. The Contractor will take action with respect to any subcontract or procurement as the County may direct as a means of enforcing such provisions including



sanctions for noncompliance. Provided, that if the Contractor becomes involved in, or is threatened with litigation by a subcontractor, or supplier because of such direction, the Contractor may request the County to enter into any litigation to protect the interests of the County. In addition, the Contractor may request the United States to enter into the litigation to protect the interests of the United States.

16. Compliance with Laws. Contractor shall secure any and all permits, licenses and approvals that may be required in order to perform the Services, shall exercise full and complete authority over Contractor's personnel, shall comply with all workers' compensation, employer's liability and all other federal, state, county, and municipal laws, ordinances, rules and regulations required of an employer performing services such as the Services, and shall make all reports and remit all withholdings or other deductions from the compensation paid to Contractor's personnel as may be required by any federal, state, county, or municipal law, ordinance, rule, or regulation.

17. Conflict of Interest. The Contractor covenants that it presently has no interest and shall not acquire any interest, directly or indirectly which could conflict in any manner or degree with the performance of the Services. The Contractor further covenants that in the performance of this Agreement, no person having any such interest shall knowingly be employed by the Contractor. The Contractor guarantees that he/she has not offered or given to any member of, delegate to the Congress of the United States, any or part of this contract or to any benefit arising therefrom.

18. Independent Contractor. Contractor enters into this Agreement as, and shall continue to be, an independent contractor. All services shall be performed only by Contractor and Contractor's employees. Under no circumstances shall Contractor or any of Contractor's employees look to the County as his/her employer, or as partner, agent or principal. Neither Contractor, nor any of Contractor's employees, shall be entitled to any benefits accorded to the County's employees, including without limitation worker's compensation, disability insurance, vacation or sick pay. Contractor shall be responsible for providing, at Contractor's expense, and in Contractor's name, unemployment, disability, worker's compensation and other insurance as well as licenses and permits usual and necessary for conducting the services to be provided under this Agreement.

19. Third Party Beneficiaries. It is specifically agreed between the parties executing this Agreement that it is not intended by any of the provisions of any part of the Agreement to create in the public or any member thereof, a third party beneficiary under this Agreement, or to authorize anyone not a party to this Agreement to maintain a suit for personal injuries or property damage pursuant to the terms or provisions of this Agreement.

20. Indemnification and Waiver of Liability. The Contractor agrees, to the fullest extent permitted by law, to defend, indemnify and hold harmless the County, its agents, representatives, officers, directors, officials and employees from and against claims, damages, losses and expenses (including but not limited to attorney's fees, court costs and costs of appellate proceedings) relating to, arising out of or resulting from the Contractor's negligent acts, errors, mistakes or omissions relating to professional Services performed under this Agreement. The Contractor's duty to defend, hold harmless and indemnify the County its agents, representatives, officers, directors, officials and employees shall arise in connection with any claim, damage, loss or expense that is



attributable to bodily injury; sickness; disease; death; or injury to impairment, or destruction of tangible property including loss of use resulting therefrom, caused by any negligent acts, errors, mistakes or omissions related to Services in the performance of this Agreement including any person for whose acts, errors, mistakes or omissions the Contractor may be legally liable. The parties agree that TEN DOLLARS (\$10.00) represents specific consideration to the Contractor for the indemnification set forth herein.

The waiver by a party of any breach or default in performance shall not be deemed to constitute a waiver of any other or succeeding breach or default. The failure of the County to enforce any of the provisions hereof shall not be construed to be a waiver of the right of the County thereafter to enforce such provisions.

21. Taxes and Assessments. Contractor agrees to pay all sales, use, or other taxes, assessments and other similar charges when due now or in the future, required by any local, state or federal law, including but not limited to such taxes and assessments as may from time to time be imposed by the County in accordance with this Agreement. Contractor further agrees that it shall protect, reimburse and indemnify County from and assume all liability for its tax and assessment obligations under the terms of the Agreement.

The County is exempt from payment of Florida state sales and use taxes. The Contractor shall not be exempted from paying sales tax to its suppliers for materials used to fulfill contractual obligations with the County, nor is the Contractor authorized to use the County's tax exemption number in securing such materials.

The Contractor shall be responsible for payment of its own and its share of its employees' payroll, payroll taxes, and benefits with respect to this Agreement.

22. Prohibition Against Contracting with Scrutinized Companies. Pursuant to Florida Statutes Section 215.4725, contracting with any entity that is listed on the Scrutinized Companies that Boycott Israel List or that is engaged in the boycott of Israel is prohibited. Contractors must certify that the company is not participating in a boycott of Israel. Any contract for goods or services of One Million Dollars (\$1,000,000) or more shall be terminated at the County's option if it is discovered that the entity submitted false documents of certification, is listed on the Scrutinized Companies with Activities in Sudan List, the Scrutinized Companies with Activities in the Iran Petroleum Energy Sector List, or has been engaged in business operations in Cuba or Syria after July 1, 2018.

Any contract entered into or renewed after July 1, 2018 shall be terminated at the County's option if the company is listed on the Scrutinized Companies that Boycott Israel List or engaged in the boycott of Israel. Contractors must submit the certification that is attached to this agreement as Attachment "D". Submitting a false certification shall be deemed a material breach of contract. The County shall provide notice, in writing, to the Contractor of the County's determination concerning the false certification. The Contractor shall have ninety (90) days following receipt of the notice to respond in writing and demonstrate that the determination was in error. If the Contractor does not demonstrate that the County's determination of false certification was made



in error, then the County shall have the right to terminate the contract and seek civil remedies pursuant to Florida Statute Section 215.4725.

23. Inconsistencies and Entire Agreement. If there is a conflict or inconsistency between any term, statement, requirement, or provision of any attachment attached hereto, any document or events referred to herein, or any document incorporated into this Agreement, the term, statement, requirement, or provision contained in this Agreement shall prevail and be given superior effect and priority over any conflicting or inconsistent term, statement, requirement or provision contained in any other document or attachment, including but not limited to Attachments listed in Section 1.

24. Severability. If any term or condition of this Contract shall be deemed, by a court having appropriate jurisdiction, invalid or unenforceable, the remainder of the terms and conditions of this Contract shall remain in full force and effect. This Contract shall not be more strictly construed against either party hereto by reason of the fact that one party may have drafted or prepared any or all the terms and provisions hereof.

25. Entire Agreement. This Agreement contains the entire agreement of the parties, and may be amended, waived, changed, modified, extended or rescinded only by in writing signed by the party against whom any such amendment, waiver, change, modification, extension and/or rescission is sought.

26. Representation of Authority to Contractor/Signatory. The individual signing this Agreement on behalf of Contractor represents and warrants that he or she is duly authorized and has legal capacity to execute and deliver this Agreement. The signatory represents and warrants to the County that the execution and delivery of this Agreement and the performance of the Services and obligations hereunder have been duly authorized and that the Agreement is a valid and legal agreement binding on the Contractor and enforceable in accordance with its terms.

(Remainder of Page Intentionally Left Blank)



IN WITNESS WHEREOF, the parties hereto have executed this Agreement in duplicate on the day and year first written above.

WITNESS:

Signature

BY: _____

Print Name

ATTEST:

OKALOOSA COUNTY, FLORIDA

J.D. Peacock II, Clerk of Courts

BY: _____
Robert A. 'Trey' Goodwin, III, Chairman



Attachment "A"



Attachment "B"
Insurance Requirements



Attachment "C"
Civil Rights Clauses



Attachment “C”

Title VI List of Pertinent Nondiscrimination Acts and Authorities

During the performance of this Agreement, the Contractor, for itself, its assignees, and successors in interest (hereinafter referred to as the “Contractor”), as applicable, agrees to comply with the following non-discrimination statutes and authorities; including but not limited to:

- Title VI of the Civil Rights Act of 1964 (42 USC § 2000d *et seq.*, 78 stat. 252) (prohibits discrimination on the basis of race, color, national origin);
- 49 CFR part 21 (Non-discrimination in Federally-assisted programs of the Department of Transportation—Effectuation of Title VI of the Civil Rights Act of 1964);
- The Uniform Relocation Assistance and Real Property Acquisition Policies Act of 1970, (42 USC § 4601) (prohibits unfair treatment of persons displaced or whose property has been acquired because of Federal or Federal-aid programs and projects);
- Section 504 of the Rehabilitation Act of 1973 (29 USC § 794 *et seq.*), as amended (prohibits discrimination on the basis of disability); and 49 CFR part 27;
- The Age Discrimination Act of 1975, as amended (42 USC § 6101 *et seq.*) (prohibits discrimination on the basis of age);
- Airport and Airway Improvement Act of 1982 (49 USC § 471, Section 47123), as amended (prohibits discrimination based on race, creed, color, national origin, or sex);
- The Civil Rights Restoration Act of 1987 (PL 100-209) (broadened the scope, coverage and applicability of Title VI of the Civil Rights Act of 1964, the Age Discrimination Act of 1975 and Section 504 of the Rehabilitation Act of 1973, by expanding the definition of the terms “programs or activities” to include all of the programs or activities of the Federal-aid recipients, sub-recipients and contractors, whether such programs or activities are Federally funded or not);
- Titles II and III of the Americans with Disabilities Act of 1990, which prohibit discrimination on the basis of disability in the operation of public entities, public and private transportation systems, places of public accommodation, and certain testing entities (42 USC §§ 12131 – 12189) as implemented by U.S. Department of Transportation regulations at 49 CFR parts 37 and 38;
- The Federal Aviation Administration’s Nondiscrimination statute (49 USC § 47123) (prohibits discrimination on the basis of race, color, national origin, and sex);
- Executive Order 12898, Federal Actions to Address Environmental Justice in Minority Populations and Low-Income Populations, which ensures nondiscrimination against minority populations by discouraging programs, policies, and activities with disproportionately high and adverse human health or environmental effects on minority and low-income populations;
- Executive Order 13166, Improving Access to Services for Persons with Limited English Proficiency, and resulting agency guidance, national origin discrimination includes discrimination because of limited English proficiency (LEP). To ensure compliance with Title VI, you must take reasonable steps to ensure that LEP persons have meaningful access to your programs (70 Fed. Reg. at 74087 to 74100);
- Title IX of the Education Amendments of 1972, as amended, which prohibits you from discriminating because of sex in education programs or activities (20 USC 1681 *et seq.*)



Attachment "D"
Scrutinized Contractors Certificate