



INVITATION TO BID (ITB) & RESPONDENT'S ACKNOWLEDGEMENT

ITB TITLE:
Emerald Coast Convention Center Restroom
Renovations and Meeting Room Counters

ITB NUMBER:
ITB TDD 49-19

ISSUE DATE:	July 22, 2019	8:00 A.M. CST
MANDATORY PRE-BID MEETING:	August 14, 2019	9:00 A.M. CST
LAST DAY FOR QUESTIONS: ITB	August 19, 2019	3:00 P.M. CST
OPENING DATE & TIME: TIME:	August 28, 2019	3:00 P.M. CST

NOTE: BIDS RECEIVED AFTER THE BID OPENING DATE & TIME WILL NOT BE CONSIDERED.

Okaloosa County, Florida solicits your company to submit a bid on the above referenced goods or services. All terms, specifications and conditions set forth in this ITB are incorporated into your response. A bid will not be accepted unless all conditions have been met. All bids must have an authorized signature in the space provided below. All envelopes containing sealed bids must reference the "ITB Title", "ITB Number" and the "ITB Opening Date & Time". Okaloosa County is not responsible for lost or late delivery of bids by the U.S. Postal Service or other delivery services used by the respondent. Neither faxed nor electronically submitted bids will be accepted. Bids may not be withdrawn for a period of ninety (90) days after the bid opening unless otherwise specified.

RESPONDENT ACKNOWLEDGEMENT FORM BELOW MUST BE COMPLETED, SIGNED, AND RETURNED AS PART OF YOUR BID. BIDS WILL NOT BE ACCEPTED WITHOUT THIS FORM, SIGNED BY AN AUTHORIZED AGENT OF THE RESPONDENT.

COMPANY NAME _____
MAILING ADDRESS _____

CITY, STATE, ZIP _____
FEDERAL EMPLOYER'S IDENTIFICATION NUMBER (FEIN): _____
TELEPHONE NUMBER: _____ EXT: _____ FAX: _____
EMAIL: _____

I CERTIFY THAT THIS BID IS MADE WITHOUT PRIOR UNDERSTANDING, AGREEMENT, OR CONNECTION WITH ANY OTHER RESPONDENT SUBMITTING A BID FOR THE SAME MATERIALS, SUPPLIES, EQUIPMENT OR SERVICES, AND IS IN ALL RESPECTS FAIR AND WITHOUT COLLUSION OR FRAUD. I AGREE TO ABIDE BY ALL TERMS AND CONDITIONS OF THIS BID AND CERTIFY THAT I AM AUTHORIZED TO SIGN THIS BID FOR THE RESPONDENT.

AUTHORIZED SIGNATURE: _____ TYPED OR PRINTED NAME _____

TITLE: _____ DATE _____

NOTICE TO BIDDERS
ITB TDD 49-19

Notice is hereby given that the Board of County Commissioners of Okaloosa County, FL, will accept sealed bids until 3:00 p.m. (CST) August 28, 2019, for the **Emerald Coast Convention Center Restroom Renovations and Meeting Room Counters**.

Interested respondents desiring consideration shall provide one (1) original and two (2) copies of their Invitation to Bids (ITB) response with the respondent's areas of expertise identified. Submissions shall be portrait orientation, unbound, and 8 ½" x 11" where practical.

All originals must have original signatures in blue ink. Bid documents are available for download by accessing the Okaloosa County website at <http://www.myokaloosa.com/purchasing/home> then accessing the link "View Current Solicitations" or by accessing the Florida Purchasing Group website at <http://www.floridabidsystem.com/Bids/ViewOpenSolicitations.asp>

A **mandatory pre-proposal** meeting will be held at 9:00 a.m. (CST), **August 14, 2019** at the **Emerald Coast Convention Center** located at **1250 Miracle Strip Pkwy SE, Fort Walton Beach, FL 32548**.

At **3:00 p.m. (CST), August 28, 2019**, all bids will be opened and read aloud. All bids must be in sealed envelopes reflecting on the outside thereof the Respondent's name and "**Emerald Coast Convention Center Restroom Renovations and Meeting Room Counters**" The County will consider all bids properly submitted at its scheduled bid opening in the **Okaloosa County Courthouse** located at 101 E. James Lee Boulevard, Room 282, Crestview, FL 32536.

****NOTE: MUST RING DOORBELL TO GAIN ENTRANCE INTO ROOM 282. THE CLERK WILL COME ACCEPT YOUR PACKAGE OR SHOW YOU TO THE CONFERENCE ROOM FOR THE SCHEDULED BID OPENING****

NOTE: THE NEW CRESTVIEW COURTHOUSE HAS SECURITY AT ENTRY POINT-PLEASE ALLOW FOR TIME TO GET THROUGH SECURITY WHEN ARRIVING FOR THE BID OPENING.

NOTE: Crestview, FL is not a next day guaranteed delivery location by most delivery services. Respondents using mail or delivery services assume all risks of late or non-delivery.

The County reserves the right to award the bid to the lowest responsive respondent and to waive any irregularity or technicality in bids received. Okaloosa County shall be the sole judge of the bid and the resulting Agreement that is in its best interest and its decision shall be final. The County reserves the right to award to multiple vendors if it is in the best interest of the County.

Any Respondent failing to mark outside of the envelope as set forth herein may not be entitled to have their bid considered.

All bids should be addressed as follows:

Emerald Coast Convention Center Restroom Renovations and Meeting Room Counters

Okaloosa Clerk of Courts
101 E James Lee Blvd, Rm. 282 Crestview, FL
32536

Jeffrey Hyde
Purchasing Manager

Date

OKALOOSA COUNTY
BOARD OF COUNTY COMMISSIONERS
Charles K. Windes
Chairman

GENERAL SERVICES INSURANCE REQUIREMENTS

REVISED: 08/01/2018

BONDING REQUIREMENTS

1. **Bid Bond:** A bid bond, in the form prescribed, Cashier's or Certified check, is required in an amount not less than five percent (5%) of the total contract amount. The Bid Bond must be attached to the bid.

2. **Performance and Payment Bond:** The successful Respondent shall furnish to the County, without extra compensation, and shall maintain in effect throughout the life of the Contract, and for the duration of the period described in the bond, acceptable Performance and Payment bonds in sums at least equal to the full amount of the Contract, conditioned to indemnify and save harmless the County from and against any loss, damage, or expense ensuing from failure on the part of the Contractor to faithfully and properly perform the Contract or to promptly pay all its subcontractors, suppliers, material, men or laborers for work completed on the Project. The required forms for the performance and payment bonds are included herein.

If within ten (10) calendar days after the acceptance of the bid, the successful Respondent shall refuse or neglect to execute the contract and to furnish the required performance and payment bonds properly signed by the Respondent and the surety or sureties satisfactorily to the County, the Respondent shall be deemed to be in default and the County will retain the bid surety as liquidated damages, but not as a penalty. The County reserves the option to accept the bid of any of the other Respondents within ten (10) calendar days from default, in which case such acceptance shall have the same effect on such Respondent as though they were the original, successful Respondent.

CONTRACTORS INSURANCE

1. The Contractor shall not commence any work in connection with this Agreement until he has obtained all required insurance and such insurance has been approved by the Okaloosa County Risk Manager or designee.

2. All insurance policies shall be with insurers authorized to do business in the State of Florida.

3. All insurance shall include the interest of all entities named and their respective officials, employees & volunteers of each and all other interests as may be reasonably required by Okaloosa County. The coverage afforded the Additional Insured under this policy shall be primary insurance. If the Additional Insured have other insurance that is applicable to the loss, such other insurance shall be on an excess or contingent basis. The amount of the company's liability under this policy shall not be reduced by the existence of such other insurance.

4. Where applicable, the County shall be shown as an Additional Insured with a Waiver of Subrogation on the Certificate of Insurance.

5. The County shall retain the right to reject all insurance policies that do not meet the requirement of this Agreement. Further, the County reserves the right to change these insurance requirements with 60-day notice to the Contractor.

6. The County reserves the right at any time to require the Contractor to provide copies (redacted if necessary) of any insurance policies to document the insurance coverage specified in this Agreement.
7. The designation of Contractor shall include any associated or subsidiary company which is involved and is a part of the contract and such, if any associated or subsidiary company involved in the project must be named in the Workers' Compensation coverage.
8. Any exclusions or provisions in the insurance maintained by the Contractor that excludes coverage for work contemplated in this agreement shall be deemed unacceptable and shall be considered breach of contract.

WORKERS' COMPENSATION INSURANCE

1. The Contractor shall secure and maintain during the life of this Agreement Workers' Compensation insurance for all of his employees employed for the project or any site connected with the work, including supervision, administration or management, of this project and in case any work is sublet, with the approval of the County, the Contractor shall require the Subcontractor similarly to provide Workers' Compensation insurance for all employees employed at the site of the project, and such evidence of insurance shall be furnished to the County not less than ten (10) days prior to the commencement of any and all sub-contractual Agreements which have been approved by the County.
2. Contractor must be in compliance with all applicable State and Federal workers' compensation laws, including the U.S. Longshore Harbor Workers' Act or Jones Act, if applicable.
3. No class of employee, including the Contractor himself, shall be excluded from the Workers' Compensation insurance coverage. The Workers' Compensation insurance shall also include Employer's Liability coverage.

BUSINESS AUTOMOBILE LIABILITY

Coverage must be afforded for all Owned, Hired, Scheduled, and Non-Owned vehicles for Bodily Injury and Property Damage in an amount not less than \$1,000,000 combined single limit each accident. If the contractor does not own vehicles, the contractor shall maintain coverage for Hired & Non-Owned Auto Liability, which may be satisfied by way of endorsement to the Commercial General Liability policy or separate Business Auto Policy. Contractor must maintain this insurance coverage throughout the life of this Agreement.

COMMERCIAL GENERAL LIABILITY INSURANCE

1. The Contractor shall carry other Commercial General Liability insurance against all other Bodily Injury, Property Damage and Personal and Advertising Injury exposures.
2. All liability insurance (other than Professional Liability) shall be written on an occurrence basis and shall not be written on a claims-made basis. If the insurance is issued with an aggregate limit of liability, the aggregate limit of liability shall apply only to the locations included in this Agreement. If, as the result of any claims or other reasons, the available limits of insurance reduce to less than those stated in the Limits of Liability, the Contractor shall notify the County representative in writing. The Contractor shall purchase additional liability insurance to maintain the requirements established in this Agreement. Umbrella or Excess Liability insurance can be purchased to meet the Limits of Liability specified in this Agreement.

3. Commercial General Liability coverage shall include the following:

- 1.) Premises & Operations Liability
- 2.) Bodily Injury and Property Damage Liability
- 3.) Independent Contractors Liability
- 4.) Contractual Liability
- 5.) Products and Completed Operations Liability

4. Contractor shall agree to keep in continuous force Commercial General Liability coverage for the length of the contract.

LIMITS OF LIABILITY

The insurance required shall be written for not less than the following, or greater if required by law and shall include Employer's liability with limits as prescribed in this contract:

	<u>LIMIT</u>
1. Worker's Compensation	
1.) State	Statutory
2.) Employer's Liability	\$500,000 each accident
2. Business Automobile	\$1,000,000 each accident (A combined single limit)
3. Commercial General Liability	\$1,000,000 each occurrence for Bodily Injury & Property Damage \$1,000,000 each occurrence Products and completed operations
4. Personal and Advertising Injury	\$1,000,000 each occurrence

NOTICE OF CLAIMS OR LITIGATION

The Contractor agrees to report any incident or claim that results from performance of this Agreement. The County representative shall receive written notice in the form of a detailed written report describing the incident or claim within ten (10) days of the Contractor's knowledge. In the event such incident or claim involves injury and/or property damage to a third party, verbal notification shall be given the same day the Contractor becomes aware of the incident or claim followed by a written detailed report within ten (10) days of verbal notification.

INDEMNIFICATION & HOLD HARMLESS

Contractor shall indemnify and hold harmless the County, its officers and employees from liabilities, damages, losses, and costs including but not limited to reasonable attorney fees, to the extent caused by the negligence, recklessness, or wrongful conduct of the Contractor and other persons employed or utilized by the Contractor in the performance of this contract.

Note: For Contractor's convenience, this certification form is enclosed and is made a part of the bid package.

CERTIFICATE OF INSURANCE

1. Certificates of insurance indicating the job site and evidencing all required coverage must be submitted not less than 10 days prior to the commencement of any of the work. The certificate holder(s) shall be as follows: Okaloosa County, 5479A Old Bethel Road, Crestview, Florida, 32536.
2. The contractor shall provide a Certificate of Insurance to the County with a thirty (30) day notice of cancellation; ten (10) days' notice if cancellation is for nonpayment of premium.
3. In the event that the insurer is unable to accommodate the cancellation notice requirement, it shall be the responsibility of the contractor to provide the proper notice. Such notification shall be in writing by registered mail, return receipt requested, and addressed to the Okaloosa County Purchasing Department at 5479-A Old Bethel Road, Crestview, FL 32536.
4. In the event the contract term goes beyond the expiration date of the insurance policy, the contractor shall provide the County with an updated Certificate of insurance no later than ten (10) days prior to the expiration of the insurance currently in effect. The County reserves the right to suspend the contract until this requirement is met.
5. The certificate shall indicate if coverage is provided under a claims-made or occurrence form. If any coverage is provided on a claims-made form, the certificate will show a retroactive date, which should be the same date of the initial contract or prior.
6. All certificates shall be subject to Okaloosa County's approval of adequacy of protection and the satisfactory character of the Insurer.
7. All deductibles or SIRs, whether approved by Okaloosa County or not, shall be the Contractor's full responsibility. In particular, the Contractor shall afford full coverage as specified herein to entities listed as Additional Insured.
8. In no way will the entities listed as Additional Insured be responsible for, pay for, be damaged by, or limited to coverage required by this schedule due to the existence of a deductible or SIR.

GENERAL TERMS

Any type of insurance or increase of limits of liability not described above which, the Contractor required for its own protection or on account of statute shall be its own responsibility and at its own expense.

Any exclusions or provisions in the insurance maintained by the contractor that excludes coverage for work contemplated in this contract shall be deemed unacceptable and shall be considered breach of contract.

The carrying of the insurance described shall in no way be interpreted as relieving the Contractor of any responsibility under this contract.

Should the Contractor engage a subcontractor or sub-subcontractor, the same conditions will apply under this Agreement to each subcontractor and sub-subcontractor.

The Contractor hereby waives all rights of subrogation against Okaloosa County and its consultants and other indemnities of the Contractor under all the foregoing policies of insurance.

UMBRELLA INSURANCE

The Contractor shall have the right to meet the liability insurance requirements with the purchase of an umbrella insurance policy. In all instances, the combination of primary and umbrella liability coverage must equal or exceed the minimum liability insurance limits stated in this Agreement. Okaloosa County will be listed as an additional insured with a waiver of subrogation.

GENERAL CONDITIONS

1. PRE-BID ACTIVITY -

Except as provided in this section, respondents are prohibited from contacting or lobbying the County, County Administrator, Commissioners, County staff, and Review Committee members, or any other person authorized on behalf of the County related or involved with the solicitation. All inquiries on the scope of work, specifications, additional requirements, attachments, terms and general conditions or instructions, or any issue must be directed in writing, by US mail or email to:

Okaloosa County Purchasing Department
5479A Old Bethel Road
Crestview, FL 32536
Email: dmason@myokaloosa.com
(850) 689-5960

All questions or inquiries must be received no later than the last day for questions (reference ITB & Respondent's Acknowledgement form). Any addenda or other modification to the bid documents will be issued by the County five (5) days prior to the date and time of bid closing, as written addenda, and will be posted to and the Okaloosa County website at <http://www.myokaloosa.com/purchasing/current-solicitations> and the Bidnet website at <https://www.bidnetdirect.com/florida>.

Such written addenda or modification shall be part of the bid documents and shall be binding upon each respondent. Each respondent is required to acknowledge receipt of any and all addenda in writing and submit with their bid. No respondent may rely upon any verbal modification or interpretation.

- 2. PREPARATION OF BID** – The bid form is included with the bid documents. Additional copies may be obtained from the County. The respondent shall submit bids in accordance with the public notice.

All blanks in the bid documents shall be completed by printing in ink or by typewriter in both words and numbers with the amounts extended, totaled and the bid signed. A bid price shall be indicated for each section, bid item, alternative, adjustment unit price item, and unit price item listed therein, or the words “No Bid”, “No Change”, or “Not Applicable” entered. No changes shall be made to the phraseology of the form or in the items mentioned therein. In case of any discrepancy between the written amount and the numerical figures, the written amount shall govern. Any bid which contains any omissions, erasures, alterations, additions, irregularities of any kind, or items not called for which shall in any manner fail to conform to the conditions of public notice inviting bids may be rejected.

A bid submitted by a partnership shall be executed in the partnership name and signed by a partner (whose title must appear under the signature). The official address of the partnership shall be shown below the signature.

A bid submitted by a limited liability company shall be executed in the name of the firm by

a member and accompanied by evidence of authority to sign. The state of formation of the firm and the official address of the firm must be shown below the signature.

A bid submitted by an individual shall show the respondent's name and official address.

A bid submitted by a joint venture shall be executed by each joint venture in the manner indicated on the bid form. The official address of the joint venture must be shown below the signature.

It is preferred that all signatures be in blue ink with the names type or printed below the signature. Okaloosa County does not accept electronic signatures.

The bid shall contain an acknowledgement of receipt of all Addenda, the numbers of which shall be filled in on the form. The address and telephone # for communications regarding the bid shall be shown.

If the respondent is an out-of-state corporation, the bid shall contain evidence of respondent's authority and qualification to do business as an out-of-state corporation in the State of Florida. A state contractor license # for the State of Florida shall also be included on the bid form. Respondent shall be licensed in accordance with the requirements of Chapter 489, Florida Statutes.

3. **INTEGRITY OF BID DOCUMENTS** - Respondents shall use the original Bid documents provided by the Purchasing Department and enter information only in the spaces where a response is requested. Respondents may use an attachment as an addendum to the Bid documents if sufficient space is not available. Any modifications or alterations to the original bid documents by the respondent, whether intentional or otherwise, will constitute grounds for rejection of a bid. Any such modification or alteration that a respondent wish to propose must be clearly stated in the respondent's response in the form of an addendum to the original bid documents.
4. **SUBMITTAL OF BID** – A bid shall be submitted no later than the date and time prescribed and at the place indicated in the advertisement or invitation to bid and shall be enclosed in an opaque sealed envelope plainly marked with the project title (and, if applicable, the designated portion of the project for which the bid is submitted), the name and address of the respondent, and shall be accompanied by the bid security and other required documents. It is the respondent's responsibility to assure that its bid is delivered at the proper time and place. Offers by telegram, facsimile, or telephone will **NOT** be accepted.

Note: Crestview is not a next day delivery site for overnight carriers.

5. **MODIFICATION & WITHDRAWAL OF BID** - A bid may be modified or withdrawn by an appropriate document duly executed in the manner that a bid must be executed and delivered to the place where bids are to be submitted prior to the date and time for the opening of bids.

If within 24 hours after bids are opened any respondent files a duly signed written notice with the County and promptly thereafter demonstrates to the reasonable satisfaction of the County that there was a material substantial mistake in the preparation of its bid, that respondent may withdraw its bid, and the bid security may be returned. Thereafter, if the work is rebid, that respondent will be disqualified from 1) further bidding on the work, and 2) doing any work on the contract, either as a subcontractor or in any other capacity.

6. **BIDS TO REMAIN SUBJECT TO ACCEPTANCE** – All bids will remain subject to acceptance or rejection for ninety (90) calendar days after the day of the bid opening, but the County may, in its sole discretion, release any bid and return the bid security prior to the end of this period.
7. **IDENTICAL TIE BIDS** - – In cases of identical procurement responses, the award shall be determined either by lot or on the basis of factors deemed to serve the best interest of the County. In the case of the latter, there must be adequate documentation to support such a decision.
8. **CONDITIONAL & INCOMPLETE BIDS** - Okaloosa County specifically reserves the right to reject any conditional bid and bids which make it impossible to determine the true amount of the bid.
9. **PRICING** – The bid price shall include all equipment, labor, materials, freight, taxes etc. Okaloosa County reserves the right to select that bid most responsive to our needs.
10. **ADDITION/DELETION OF ITEM** – The County reserves the right to add or delete any item from this bid or resulting contract when deemed to be in the County’s best interest.
11. **SPECIFICATION EXCEPTIONS** – Specifications are based on the most current literature available. Respondent shall clearly list any change in the manufacturer’s specifications which conflict with the bid specifications. Respondent must also explain any deviation from the bid specification in writing, as a foot note on the applicable bid page and enclose a copy of the manufacturer’s specifications data detailing the changed item(s) with their bid. Failure of the respondent to comply with these provisions will result in respondents being held responsible for all costs required to bring the equipment in compliance with bid specifications.
12. **APPLICABLE LAWS & REGULATIONS** – All applicable Federal and State laws, County and municipal ordinances, orders, rules and regulations of all authorities having jurisdiction over the project shall apply to the bid throughout, and they will be deemed to be included in the contract the same as though they were written in full therein.
13. **DISQUALIFICATION OF RESPONDENTS** - Any of the following reasons may be considered as sufficient for the disqualification of a respondent and the rejection of its bid:
 - a. Submission of more than one proposal for the same work from an individual, firm or corporation under the same or different name.
 - b. Evidence that the respondent has a financial interest in the firm of another respondent for the same work.
 - c. Evidence of collusion among respondents. Participants in such collusion will receive no recognition as respondents for any future work of the County until such participant has been reinstated as a qualified respondent.
 - d. Uncompleted work which in the judgment of the County might hinder or prevent the prompt completion of additional work if awarded.
 - e. Failure to pay or satisfactorily settle all bills due for labor and material on former contracts in force at the time of advertisement of proposals.
 - f. Default under previous contract.

- g. Listing of the respondent by any Local, State or Federal Government on its barred/suspended vendor list.

14. AWARD OF BID

- A. **Okaloosa County Review** - Okaloosa County designated Staff will review all bids and will participate in the Recommendation to Award.
- B. The County will award the bid to the responsive and responsible vendor(s) with the lowest responsive bid(s), and the County reserves the right to award the bid to the respondent submitting a responsive bid with a resulting negotiated agreement which is most advantageous and in the best interest of the County, and to reject any and all bids or to waive any irregularity or technicality in bids received. Okaloosa County shall be the sole judge of the bid and the resulting negotiated agreement that is in its best interest and its decision shall be final.
- C. Okaloosa County reserves the right to waive any informalities or reject any and all bids, in whole or part, to utilize any applicable state contracts in lieu of or in addition to this bid and to accept the bid that in its judgment will best serve the interest of the County.
- D. Okaloosa County specifically reserves the right to reject any conditional bids and will normally reject those which made it impossible to determine the true amount of the bid. Each item must be bid separately and no attempt is to be made to tie any item or items to any other item or items.

15. PAYMENTS –The respondent shall be paid upon submission of invoices and approval of acceptance by Okaloosa County Board of County Commissioners, Finance Office, 302 N. Wilson St., #203, Crestview FL 32536, for the prices stipulated herein for articles delivered and accepted. Invoices must show Contract #.

- A. CONTRACTOR shall submit Applications for Payment in accordance with Article 15 of the General Conditions. Applications for Payment will be processed by ENGINEER as provided in the General Conditions.
- B. OWNER shall make progress payments on account of the Contract Price on the basis of CONTRACTOR's Applications for Payment in accordance with § 218.70-218.79 F.S. (Local Government Prompt Payment Act) during performance of the Work as provided below, provided that such Applications for Payment have been submitted in a timely manner and otherwise meet the requirements of the Contract
- C. Progress payments will be made in an amount equal to the percentage indicated below but, in each case, less the aggregate of payments previously made and less such amounts as OWNER may withhold, including but not limited to liquidated damages, in accordance with the Contract:
 - a. 95 percent of Work completed (with the balance being retainage)
 - b. 95 percent of cost of materials and equipment not incorporated in the Work (with the balance being retainage).
- D. Upon final completion and acceptance of the Work, OWNER shall pay the remainder of the Contract Price as recommended by ENGINEER.

16. DISCRIMINATION - An entity or affiliate who has been placed on the discriminatory vendor list may not submit a bid on a contract to provide goods or services to a public entity, may not submit a bid on a contract with a public entity for the construction or repair of a public building or public work, may not submit bids on leases of real property to a public entity, may not award or perform work as a contractor, supplier, subcontractor, or consultant under contract with any public entity, and may not transact business with any public entity.

17. PUBLIC ENTITY CRIME INFORMATION - Pursuant to Florida Statute 287.133, a respondent may not be awarded or perform work as a contractor, supplier, subcontractor, or consultant under a contract with any public entity; and may not transact business with any public entity in excess of the threshold amount provided in s. [287.017](#) for CATEGORY TWO for a period of 36 months following the date of being placed on the convicted vendor list.

18. CONFLICT OF INTEREST - The award hereunder is subject to the provisions of Chapter 112, Florida Statutes. All respondents must disclose with their bids the name of any officer, director, or agent who is also a public officer or an employee of the Okaloosa Board of County Commissioners, or any of its agencies. Furthermore, all respondents must disclose the name of any County officer or employee who owns, directly or indirectly, an interest of five percent (5%) or more in the firm or any of its branches.

Note: For respondent's convenience, this certification form is enclosed and is made a part of the bid package.

19. REORGANIZATION OR BANKRUPTCY PROCEEDINGS – Bids will not be considered from respondents who are currently involved in official financial reorganization or bankruptcy proceedings.

20. INVESTIGATION OF RESPONDENT – The County may make such investigations, as it deems necessary to determine the stability of the respondent to perform the work and that there is no conflict of interest as it relates to the project. The respondent shall furnish to the Owner any additional information and financial data for this purpose as the County may request.

21. CONE OF SILENCE CLAUSE - The Okaloosa County Board of County Commissioners has established a solicitation silence policy (**Cone of Silence Clause**) that prohibits oral and written communication regarding all formal solicitations for goods and services (formal bids, Request for Proposals, Requests for Qualifications) issued by the Board through the County Purchasing Department. The period commences from the date of advertisement until award of contract.

All communications shall be directed to the Purchasing Department.

Note: For respondent's convenience, this certification form is enclosed and is made a part of the bid package.

22. REVIEW OF PROCUREMENT DOCUMENTS - Per Florida Statute 119.071(1)(b) 2 sealed bids, proposals, or replies received by the County pursuant to a competitive solicitation are exempt from public disclosure until such time as the County provides notice of an intended decision or until 30 days after opening the bids, proposals, or final replies, whichever is earlier.

23. COMPLIANCE WITH FLORIDA STATUTE 119.0701 - The Respondent shall comply with all the provisions of section 119.0701, Florida Statutes relating to the public records which requires, among other things, that the Respondent: (a) Keep and maintain public records; (b) Provide the public with access to public records on the same terms and conditions that the public agency would provide the records; (c) ensure that public records that are exempt or confidential and exempt from public records disclosure requirements are not disclosed except as authorized by law; and (d) Meet all requirements for retaining public records and transfer, at no cost, to the public agency all public records in possession of the respondent upon termination of the contract.

24. PROTECTION OF RESIDENT WORKERS – The Okaloosa County Board of County Commissioners actively supports the Immigration and Nationality Act (INA) which includes provisions addressing employment eligibility, employment verifications, and nondiscrimination.

Under the INA, employers may hire only persons who may legally work in the United States (i.e., citizens and nationals of the U.S.) and aliens authorized to work in the U.S. The employer must verify the identity and employment eligibility of anyone to be hired, which includes completing the Employment Eligibility Verifications. The respondent shall establish appropriate procedures and controls so no services or products under the Contract Documents will be performed or manufactured by any worker who is not legally eligible to perform such services or employment. Okaloosa County reserves the right to request documentation showing compliance with the requirements.

Respondents doing construction business with Okaloosa County are required to use the Federal Government Department of Homeland Security's website and use the E-Verify Employment Eligibility Verifications System to confirm eligibility of all employees to work in the United States.

- 25. SUSPENSION OR TERMINATION FOR CONVENIENCE** - The County may, at any time, without cause, order Respondent in writing to suspend, delay or interrupt the work in whole or in part for such period of time as the County may determine, or to terminate all or a portion of the Contract for the County's convenience. Upon such termination, the Contract Price earned to the date of termination shall be paid to Respondent, but Respondent waives any claim for damages, including loss of profits arising out of or related to the early termination. Those Contract provisions which by their nature survive final acceptance shall remain in full force and effect. If the County orders a suspension, the Contract price and Contract time may be adjusted for increases in the cost and time caused by suspension, delay or interruption. No adjustment shall be made to the extent that performance is, was or would have been so suspended, delayed or interrupted by reason for which Respondent is responsible; or that an equitable adjustment is made or denied under another provision of this Contract.
- 26. FAILURE OF PERFORMANCE/DELIVERY** - In case of default by the respondent, the County after due notice (oral or written) may procure the necessary supplies or services from other sources and hold the respondent responsible for difference in cost incurred. Continuous instances of default shall result in cancellation of the award and removal of the respondent from the bid list for duration of one (1) year, at the option of the County.
- 27. AUDIT** - If requested, respondent shall permit the County or an authorized, independent audit agency to inspect all data and records of respondent relating to its performance and its subcontracts under this bid from the date of the award through three (3) years after the expiration of contract.
- 28. EQUAL EMPLOYMENT OPPORTUNITY; NON DISCRIMINATION** – Respondent will not discriminate against any employee or an applicant for employment because of race, color, religion, gender, sexual orientation, national origin, age, familial status or handicap.
- 29. NON-COLLUSION** – Respondent certifies that it has entered into no agreement to commit a fraudulent, deceitful, unlawful or wrongful act, or any act which may result in an unfair advantage over other respondents. See Florida Statute 838.22.

30. UNAUTHORIZED ALIENS/PATRIOT'S ACT – The knowing employment by respondent or its subcontractors of any alien not authorized to work by the immigration laws is prohibited and shall be a default of the contract. In the event that the respondent is notified or becomes aware of such default, the respondent shall take steps as are necessary to terminate said employment with 24 hours of notification or actual knowledge that an alien is being employed. Respondent's failure to take such steps as are necessary to terminate the employment of any said alien within 24 hours of notification or actual knowledge that an alien is being employed shall be grounds for immediate termination of the contract. Respondent shall take all commercially reasonable precautions to ensure that it and its subcontractors do not employ persons who are not authorized to work by the immigration laws.

The following documents are to be submitted with the qualifications packet:

- A. Drug-Free Workplace Certification Form
- B. Conflict of Interest
- C. Federal E-Verify
- D. Code of Silence Form
- E. Recycled Content Form
- F. Indemnification and Hold Harmless
- G. Prohibition to Lobbying
- H. Company Data
- I. System of Awards Management
- J. Addendum Acknowledgement
- K. Bid Sheet
- L. Anti-Collusion Statement
- M. Vendors on Scrutinized Companies List

DRUG-FREE WORKPLACE CERTIFICATION

THE BELOW SIGNED PROPOSER CERTIFIES that it has implemented a drug-free workplace program. In order to have a drug-free workplace program, a business shall:

1. Publish a statement notifying employees that the unlawful manufacture, distribution, dispensing, possession, or use of a controlled substance is prohibited in the workplace and specifying the actions that will be taken against employees for violations of such prohibition.
2. Inform employees about the dangers of drug abuse in the workplace, the business's policy of maintaining a drug-free workplace, any available drug counseling, rehabilitation and employee assistance programs, and the penalties that may be imposed upon employees for drug abuse violations.
3. Give each employee engaged in providing the commodities or contractual services that are under quote a copy of the statement specified in subsection 1.
4. In the statement specified in subsection 1, notify the employees that, as a condition of working on the commodities or contractual services that are under quote, the employee will abide by the terms of the statement and will notify the employer of any conviction of, or plea of guilty or nolo contendere to any violation of Chapter 893 or of any controlled substance law of the United States or any state, for a violation occurring in the workplace no later than five (5) days after such conviction.
5. Impose a sanction on, or require the satisfactory participation in, drug abuse assistance or rehabilitation program if such is available in employee's community, by any employee who is convicted.
6. Make a good faith effort to continue to maintain a drug-free workplace through implementation of this section.

As the person authorized to sign this statement, I certify that this firm complies fully with the above requirements.

DATE: _____

SIGNATURE: _____

COMPANY: _____

NAME: _____

(Typed or Printed)

ADDRESS: _____

TITLE: _____

E-MAIL: _____

PHONE NO.: _____

CONFLICT OF INTEREST DISCLOSURE FORM

For purposes of determining any possible conflict of interest, all bidders/proposers, must disclose if any Okaloosa Board of County Commissioner, employee(s), elected officials(s), of if any of its agencies is also an owner, corporate officer, agency, employee, etc., of their business.

Indicate either "yes" (a county employee, elected official, or agency is also associated with your business), or "no". If yes, give person(s) name(s) and position(s) with your business.

YES _____

NO _____

NAME(S)

POSITION(S)

FIRM NAME: _____

BY (PRINTED): _____

BY (SIGNATURE): _____

TITLE: _____

ADDRESS: _____

PHONE NO. _____

E-MAIL _____

FEDERAL E-VERIFY COMPLIANCE CERTIFICATION

In accordance with Okaloosa County Policy and Executive Order Number 11-116 from the office of the Governor of the State of Florida, Proposer hereby certifies that the U.S. Department of Homeland Security's E-Verify system will be used to verify the employment eligibility of all new employees hired by the Respondent during the contract term, and shall expressly require any subcontractors performing work or providing services pursuant to the contract to likewise utilize the U.S. Department of Homeland Security's E-Verify system to verify the employment eligibility of all new employees hired by the subcontractor during the contract term; and shall provide documentation of such verification to the COUNTY upon request.

=====

As the person authorized to sign this statement, I certify that this company complies/will comply fully with the above requirements.

DATE: _____

SIGNATURE: _____

COMPANY: _____

NAME: _____

(Typed or Printed)

ADDRESS: _____

TITLE: _____

PHONE NO.: _____

E-MAIL: _____

CONE OF SILENCE CLAUSE

The Board of County Commissioners have established a solicitation silence policy (**Cone of Silence**) that prohibits oral and written communication regarding all formal solicitations for goods and services (ITB, RFP, ITQ, ITN, and RFQ) or other competitive solicitation between the bidder (or its agents or representatives) or other entity with the potential for a financial interest in the award (or their respective agents or representatives) regarding such competitive solicitation, and any County Commissioner or County employee, selection committee member or other persons authorized to act on behalf of the Board including the County's Architect, Engineer or their sub consultants, or anyone designated to provide a recommendation to award a particular contract, other than the Purchasing Department Staff..

The period commences from the time of advertisement until contract award.

When the solicitation silence period is in effect, no oral or written communication is allowed regarding the solicitation between prospective respondents and members of the Board of County Commissioners, the County Administrator, county employees or members of the Board Approved Review Committee. All questions or requests for information regarding the solicitation **MUST** be directed to the designated Purchasing Representative listed in the solicitation.

Any information thought to affect the committee or staff recommendation submitted after bids are due, should be directed to the Purchasing Director or an appointed representative. It shall be the Purchasing Director decision whether to consider this information in the decision process.

Any violation of this policy shall be grounds to disqualify the respondent from consideration during the selection process.

All respondents must agree to comply with this policy by signing the following statement and including it with their submittal.

I _____ representing _____
Signature Company Name

On this ___ day of _____ 2019 hereby agree to abide by the County's "**Cone of Silence Clause**" and understand violation of this policy shall result in disqualification of my proposal/submittal.

RECYCLED CONTENT FORM

RECYCLED CONTENT INFORMATION

1. Is the material in the above: Virgin _____ or Recycled _____ (Check the applicable blank)

If recycled what percentage? _____%

Product Description: _____

2. If your product packaged and/or shipped in material containing recycled content?

Yes _____ No _____

Specify: _____

3. Is your product recyclable after it has reached its intended end use?

Yes _____ No _____

Specify: _____

The above is not applicable if there is only a personal service involved with no product involvement.

Name of Respondent: _____

E-Mail: _____

INDEMNIFICATION AND HOLD HARMLESS

RESPONDENT shall indemnify and hold harmless COUNTY, its officers and employees from liabilities, damages, losses, and costs including but not limited to reasonable attorney fees, to the extent caused by the negligence, recklessness, or intentional wrongful conduct of the RESPONDENT and other persons employed or utilized by the RESPONDENT in the performance of this Agreement.

Proposer's Company Name

Authorized Signature – Manual

Physical Address

Authorized Signature – Typed

Mailing Address

Title

Phone Number

FAX Number

Cellular Number

After-Hours Number(s)

DATE

LOBBYING - 31 U.S.C. 1352, 49 CFR Part 19, 49 CFR Part 20

APPENDIX A, 49 CFR PART 20--CERTIFICATION REGARDING LOBBYING

Certification for Contracts, Grants, Loans, and Cooperative Agreements

(To be submitted with each bid or offer exceeding \$100,000)

The undersigned [Contractor] certifies, to the best of his or her knowledge and belief, that:

1. No Federal appropriated funds have been paid or will be paid, by or on behalf of the undersigned, to any person for influencing or attempting to influence an officer or employee of an agency, a Member of Congress, an officer or employee of Congress, or an employee of a Member of Congress in connection with the awarding of any Federal contract, the making of any Federal grant, the making of any Federal loan, the entering into of any cooperative agreement, and the extension, continuation, renewal, amendment, or modification of any Federal contract, grant, loan, or cooperative agreement.
2. If any funds other than Federal appropriated funds have been paid or will be paid to any person for making lobbying contacts to an officer or employee of any agency, a Member of Congress, an officer or employee of Congress, or an employee of a Member of Congress in connection with this Federal contract, grant, loan, or cooperative agreement, the undersigned shall complete and submit Standard Form--LLL, "Disclosure Form to Report Lobbying," in accordance with its instructions [as amended by "Government wide Guidance for New Restrictions on Lobbying," 61 Fed. Reg. 1413 (1/19/96). Note: Language in paragraph (2) herein has been modified in accordance with Section 10 of the Lobbying Disclosure Act of 1995 (P.L. 104-65, to be codified at 2 U.S.C. 1601, *et seq.*)]
3. The undersigned shall require that the language of this certification be included in the award documents for all subawards at all tiers (including subcontracts, subgrants, and contracts under grants, loans, and cooperative agreements) and that all subrecipients shall certify and disclose accordingly.

This certification is a material representation of fact upon which reliance was placed when this transaction was made or entered into. Submission of this certification is a prerequisite for making or entering into this transaction imposed by 31, U.S.C. § 1352 (as amended by the Lobbying Disclosure Act of 1995). Any person who fails to file the required certification shall be subject to a civil penalty of not less than \$10,000 and not more than \$100,000 for each such failure.

[Note: Pursuant to 31 U.S.C. § 1352(c)(1) -(2)(A), any person who makes a prohibited expenditure or fails to file or amend a required certification or disclosure form shall be subject to a civil penalty of not less than \$10,000 and not more than \$100,000 for each such expenditure or failure.]

The Contractor, _____, certifies or affirms the truthfulness and accuracy of each statement of its certification and disclosure, if any. In addition, the Contractor understands and agrees that the provisions of 31 U.S.C. A 3801, *et seq.*, apply to this certification and disclosure, if any.

_____ Signature of Contractor's Authorized Official

_____ Name and Title of Contractor's Authorized Official

_____ Date

COMPANY DATA

Respondent's Company Name: _____

Physical Address & Phone #: _____

Contact Person (Typed-Printed): _____

Phone #: _____

Cell #: _____

Federal ID or SS #: _____

DUNNS #: _____

Respondent's License #: _____

Fax #: _____

Emergency #'s After Hours,
Weekends & Holidays: _____

Email Address: _____

SYSTEM FOR AWARD MANAGEMENT (OCT 2016)

(a) Definitions. As used in this provision.

“Electronic Funds Transfer (EFT) indicator” means a four-character suffix to the unique entity identifier. The suffix is assigned at the discretion of the commercial, nonprofit, or Government entity to establish additional System for Award Management records for identifying alternative EFT accounts (see [subpart 32.11](#)) for the same entity.

“Registered in the System for Award Management (SAM) database” means that.

(1) The Offeror has entered all mandatory information, including the unique entity identifier and the EFT indicator, if applicable, the Commercial and Government Entity (CAGE) code, as well as data required by the Federal Funding Accountability and Transparency Act of 2006 (see [subpart 4.14](#)) into the SAM database;

(2) The offeror has completed the Core, Assertions, and Representations and Certifications, and Points of Contact sections of the registration in the SAM database;

(3) The Government has validated all mandatory data fields, to include validation of the Taxpayer Identification Number (TIN) with the Internal Revenue Service (IRS). The offeror will be required to provide consent for TIN validation to the Government as a part of the SAM registration process; and

(4) The Government has marked the record “Active”.

“Unique entity identifier” means a number or other identifier used to identify a specific commercial, nonprofit, or Government entity. See www.sam.gov for the designated entity for establishing unique entity identifiers.

(b)(1) By submission of an offer, the offeror acknowledges the requirement that a prospective awardee shall be registered in the SAM database prior to award, during performance, and through final payment of any contract, basic agreement, basic ordering agreement, or blanket purchasing agreement resulting from this solicitation.

(2) The Offeror shall enter, in the block with its name and address on the cover page of its offer, the annotation “Unique Entity Identifier” followed by the unique entity identifier that identifies the Offeror’s name and address exactly as stated in the offer. The Offeror also shall enter its EFT indicator, if applicable. The unique entity identifier will be used by the Contracting Officer to verify that the Offeror is registered in the SAM database.

(c) If the Offeror does not have a unique entity identifier, it should contact the entity designated at www.sam.gov for establishment of the unique entity identifier directly to obtain one. The Offeror should be prepared to provide the following information:

(1) Company legal business name.

(2) Tradestyle, doing business, or other name by which your entity is commonly recognized.

(3) Company Physical Street Address, City, State, and Zip Code.

(4) Company Mailing Address, City, State and Zip Code (if separate from physical).

(5) Company telephone number.

(6) Date the company was started.

(7) Number of employees at your location.

(8) Chief executive officer/key manager.

(9) Line of business (industry).

(10) Company Headquarters name and address (reporting relationship within your entity).

(d) If the Offeror does not become registered in the SAM database in the time prescribed by the Contracting Officer, the Contracting Officer will proceed to award to the next otherwise successful registered Offeror.

(e) Processing time, which normally takes 48 hours, should be taken into consideration when registering. Offerors who are not registered should consider applying for registration immediately upon receipt of this solicitation.

(f) Offerors may obtain information on registration at <https://www.acquisition.gov>.

Offerors SAM information:

Entity Name: _____

Entity Address: _____

Duns Number: _____

CAGE Code: _____

BID SHEET

BID ITEM: ITB TDD 49-19 **Okaloosa County TDD – Emerald Coast Convention Center
Restroom Renovations and Meeting Room Counters**

Bid Amount – Restroom Renovations 1 & 2 \$ _____

Bid Amount – Restroom Renovations 3 & 4 \$ _____

Bid Amount – Restroom Renovations 5 & 6 \$ _____

Bid Amount – Meeting Room Counters \$ _____

TOTAL BID AMOUNT - \$ _____

The total number of days to substantial completion the project is anticipated to be two-hundred ten days (210) calendar days with the final completion date at two-hundred forty days (240).

****Estimated start date will be the middle of December 2019. ****

ANTI-COLLUSION STATEMENT: The below signed bidder has not divulged to, discussed or compared his bid with other bidders and has not **colluded with any other bidder or parties to bid whatever. Note: No premiums, rebates, or gratuities permitted either with, prior to, or after any** delivery of materials. Any such violation will result in the cancellation and/or return of material (as applicable) and the removal from bid list(s).

Bidder's Company Name

Authorized Signature – Manual

Address

Authorized Signature – Typed

Address

Title

Phone #

Fax #

Federal ID # or SS #

VENDORS ON SCRUTINIZED COMPANIES LISTS

By executing this Certificate _____, the bid proposer, certifies that it is not: (1) listed on the Scrutinized Companies that Boycott Israel List, created pursuant to section 215.4725, Florida Statutes, (2) engaged in a boycott of Israel, (3) listed on the Scrutinized Companies with Activities in Sudan List or the Scrutinized Companies with Activities in the Iran Petroleum Energy Sector List, created pursuant to section 215.473, Florida Statutes, or (4) engaged in business operations in Cuba or Syria. Pursuant to section 287.135(5), Florida Statutes, the County may disqualify the bid proper immediately or immediately terminate any agreement entered into for cause if the bid proposer is found to have submitted a false certification as to the above or if the Contractor is placed on the Scrutinized Companies that Boycott Israel List, is engaged in a boycott of Israel, has been placed on the Scrutinized Companies with Activities in Sudan List or the Scrutinized Companies with Activities in the Iran Petroleum Energy Sector List, or has been engaged in business operations in Cuba or Syria, during the term of the Agreement. If the County determines that the bid proposer has submitted a false certification, the County will provide written notice to the bid proposer. Unless the bid proposer demonstrates in writing, within 90 calendar days of receipt of the notice, that the County's determination of false certification was made in error, the County shall bring a civil action against the bid proposer. If the County's determination is upheld, a civil penalty shall apply, and the bid proposer will be ineligible to bid on any Agreement with a Florida agency or local governmental entity for three years after the date of County's determination of false certification by bid proposer.

As the person authorized to sign this statement, I certify that this firm complies fully with the above requirements.

DATE: _____

SIGNATURE: _____

COMPANY: _____

NAME: _____

(Typed or Printed)

ADDRESS: _____

TITLE: _____

E-MAIL: _____

PHONE NO.: _____

Standard Contract Clauses

Exhibit "B"

Title VI Clauses for Compliance with Nondiscrimination Requirements

Compliance with Nondiscrimination Requirements

During the performance of this contract, the Respondent, for itself, its assignees, and successors in interest (hereinafter referred to as the "Respondent") agrees as follows:

Compliance with Regulations: The Respondent (hereinafter includes consultants) will comply with the Title VI List of Pertinent Nondiscrimination Acts And Authorities, as they may be amended from time to time, which are herein incorporated by reference and made a part of this contract.

Non-discrimination: The Respondent, with regard to the work performed by it during the contract, will not discriminate on the grounds of race, color, or national origin in the selection and retention of subcontractors, including procurements of materials and leases of equipment. The Respondent will not participate directly or indirectly in the discrimination prohibited by the Nondiscrimination Acts and Authorities, including employment practices when the contract covers any activity, project, or program set forth in Appendix B of 49 CFR part 21.

Solicitations for Subcontracts, Including Procurements of Materials and Equipment: In all solicitations, either by competitive bidding, or negotiation made by the Respondent for work to be performed under a subcontract, including procurements of materials, or leases of equipment, each potential subcontractor or supplier will be notified by the Respondent of the Respondent's obligations under this contract and the Nondiscrimination Acts And Authorities on the grounds of race, color, or national origin.

Information and Reports: The Respondent will provide all information and reports required by the Acts, the Regulations, and directives issued pursuant thereto and will permit access to its books, records, accounts, other sources of information, and its facilities as may be determined by the sponsor or the Federal Aviation Administration to be pertinent to ascertain compliance with such Nondiscrimination Acts And Authorities and instructions. Where any information required of a Respondent is in the exclusive possession of another who fails or refuses to furnish the information, the Respondent will so certify to the sponsor or the Federal Aviation Administration, as appropriate, and will set forth what efforts it has made to obtain the information.

Sanctions for Noncompliance: In the event of a Respondent's noncompliance with the Non-discrimination provisions of this contract, the sponsor will impose such contract sanctions as it or the Federal Aviation Administration may determine to be appropriate, including, but not limited to:

- a. Withholding payments to the Respondent under the contract until the Respondent complies; and/or
- b. Cancelling, terminating, or suspending a contract, in whole or in part.

Incorporation of Provisions: The Respondent will include the provisions of paragraphs one through six in every subcontract, including procurements of materials and leases of equipment, unless exempt by the Acts, the Regulations and directives issued pursuant thereto. The Respondent will take action with respect to any subcontract or procurement as the sponsor or the Federal Aviation Administration may direct as a means of enforcing such provisions including sanctions for noncompliance. Provided, that if the Respondent becomes involved in, or is threatened with litigation by a subcontractor, or supplier because of such direction, the Respondent may request the sponsor to enter into any litigation to protect the interests of the sponsor. In addition, the Respondent may request the United States to enter into the litigation to protect the interests of the United States.

Title VI List of Pertinent Nondiscrimination Acts and Authorities

Title VI List of Pertinent Nondiscrimination Acts and Authorities

During the performance of this contract, the Respondent, for itself, its assignees, and successors in interest (hereinafter referred to as the “Respondent”) agrees to comply with the following non-discrimination statutes and authorities; including but not limited to:

- Title VI of the Civil Rights Act of 1964 (42 U.S.C. § 2000d *et seq.*, 78 stat. 252), (prohibits discrimination on the basis of race, color, national origin);
- 49 CFR part 21 (Non-discrimination In Federally-Assisted Programs of The Department of Transportation—Effectuation of Title VI of The Civil Rights Act of 1964);
- The Uniform Relocation Assistance and Real Property Acquisition Policies Act of 1970, (42 U.S.C. § 4601), (prohibits unfair treatment of persons displaced or whose property has been acquired because of Federal or Federal-aid programs and projects);
- Section 504 of the Rehabilitation Act of 1973, (29 U.S.C. § 794 *et seq.*), as amended, (prohibits discrimination on the basis of disability); and 49 CFR part 27;
- The Age Discrimination Act of 1975, as amended, (42 U.S.C. § 6101 *et seq.*), (prohibits discrimination on the basis of age);
- Airport and Airway Improvement Act of 1982, (49 USC § 471, Section 47123), as amended, (prohibits discrimination based on race, creed, color, national origin, or sex);
- The Civil Rights Restoration Act of 1987, (PL 100-209), (Broadened the scope, coverage and applicability of Title VI of the Civil Rights Act of 1964, The Age Discrimination Act of 1975 and Section 504 of the Rehabilitation Act of 1973, by expanding the definition of the terms “programs or activities” to include all of the programs or activities of the Federal-aid recipients, sub-recipients and Respondents, whether such programs or activities are Federally funded or not);
- Titles II and III of the Americans with Disabilities Act of 1990, which prohibit discrimination on the basis of disability in the operation of public entities, public and private transportation systems, places of public accommodation, and certain testing entities (42 U.S.C. §§ 12131 – 12189) as implemented by Department of Transportation regulations at 49 CFR parts 37 and 38;
- The Federal Aviation Administration’s Non-discrimination statute (49 U.S.C. § 47123) (prohibits discrimination on the basis of race, color, national origin, and sex);
- Executive Order 12898, Federal Actions to Address Environmental Justice in Minority Populations and Low-Income Populations, which ensures non-discrimination against minority populations by

discouraging programs, policies, and activities with disproportionately high and adverse human health or environmental effects on minority and low-income populations;

Executive Order 13166, Improving Access to Services for Persons with Limited English Proficiency, and resulting agency guidance, national origin discrimination includes discrimination because of limited English proficiency (LEP). To ensure compliance with Title VI, you must take reasonable steps to ensure that LEP persons have meaningful access to your programs (70 Fed. Reg. at 74087 to 74100);

Title IX of the Education Amendments of 1972, as amended, which prohibits you from discriminating because of sex in education programs or activities (20 U.S.C. 1681 et seq).

FEDERAL FAIR LABOR STANDARDS ACT (FEDERAL MINIMUM WAGE)

All contracts and subcontracts that result from this solicitation incorporate by reference the provisions of 29 CFR part 201, the Federal Fair Labor Standards Act (FLSA), with the same force and effect as if given in full text. The FLSA sets minimum wage, overtime pay, recordkeeping, and child labor standards for full and part time workers.

The [*Respondent / consultant*] has full responsibility to monitor compliance to the referenced statute or regulation. The [*Respondent / consultant*] must address any claims or disputes that arise from this requirement directly with the U.S. Department of Labor – Wage and Hour Division

O C C U P A T I O N A L S A F E T Y A N D H E A L T H A C T O F 1 9 7 0

All contracts and subcontracts that result from this solicitation incorporate by reference the requirements of 29 CFR Part 1910 with the same force and effect as if given in full text. Respondent must provide a work environment that is free from recognized hazards that may cause death or serious physical harm to the employee. The Respondent retains full responsibility to monitor its compliance and their subcontractor's compliance with the applicable requirements of the Occupational Safety and Health Act of 1970 (20 CFR Part 1910). Respondent must address any claims or disputes that pertain to a referenced requirement directly with the U.S. Department of Labor – Occupational Safety and Health Administration.

E-VERIFY

Enrollment and verification requirements.

- (1) If the Respondent is not enrolled as a Federal Respondent in E-Verify at time of contract award, the Respondent shall-
 - a. Enroll. Enroll as a Federal Respondent in the E-Verify Program within thirty (30) calendar days of contract award;
 - b. Verify all new employees. Within ninety (90) calendar days of enrollment in the E-Verify program, begin to use E-Verify to initiate verification of employment eligibility of all new hires of the Respondent, who are working in the United States, whether or not assigned to the contract, within three (3) business days after the date of hire (but see paragraph (b)(3) of this section); and,

- c. Verify employees assigned to the contract. For each employee assigned to the contract, initiate verification within ninety (90) calendar days after date of enrollment or within thirty (30) calendar days of the employee's assignment to the contract, whichever date is later (but see paragraph (b)(4) of this section.)
 - (2) If the Respondent is enrolled as a Federal Respondent in E-Verify at time of contract award, the Respondent shall use E-Verify to initiate verification of employment eligibility of
 - a. All new employees.
 - i. Enrolled ninety (90) calendar days or more. The Respondent shall initiate verification of all new hires of the Respondent, who are working in the United States, whether or not assigned to the contract, within three (3) business days after the date of hire (but see paragraph (b)(3) of this section); or
 - b. Enrolled less than ninety (90) calendar days. Within ninety (90) calendar days after enrollment as a Federal Respondent in E-Verify, the Respondent shall initiate verification of all new hires of the Respondent, who are working in the United States, whether or not assigned to the contract, within three (3) business days after the date of hire (but see paragraph (b)(3) of this section); or
 - ii. Employees assigned to the contract. For each employee assigned to the contract, the Respondent shall initiate verification within ninety (90) calendar days after date of contract award or within thirty (30) days after assignment to the contract, whichever date is later (but see paragraph (b)(4) of this section.)
- (3) If the Respondent is an institution of higher education (as defined at 20 U.S.C. 1001(a)); a State of local government or the government of a Federally recognized Indian tribe, or a surety performing under a takeover agreement entered into with a Federal agency pursuant to a performance bond, the Respondent may choose to verify only employees assigned to the contract, whether existing employees or new hires. The Respondent shall follow the applicable verification requirements of (b)(1) or (b)(2), respectively, except that any requirement for verification of new employees applies only to new employees assigned to the contract.
- (4) Option to verify employment eligibility of all employees. The Respondent may elect to verify all existing employees hired after November 6, 2986 (after November 27, 2009, in the Commonwealth of the Northern Mariana Islands), rather than just those employees assigned to the contract. The Respondent shall initiate verification for each existing employee working in the United States who was hired after November 6, 1986 (after November 27, 2009, in the Commonwealth of the Northern Mariana Islands), within one hundred eighty (180) calendar days of-
 - i. Enrollment in the E-Verify program; or
 - ii. Notification to E-Verify Operations of the Respondent's decision to exercise this option, using the contract information provided in the E-Verify program Memorandum of Understanding (MOU)

- (5) The Respondent shall comply, for the period of performance of this contract, with the requirements of the E-Verify program MOU.
- i. The Department of Homeland Security (DHS) or the Social Security Administration (SSA) may terminate the Respondent's MOU and deny access to the E-Verify system in accordance with the terms of the MOU. In such case, the Respondent, will be referred to a suspension or debarment official.
 - ii. During the period between termination of the MOU and a decision by the suspension or debarment official whether to suspend or debar, the Respondent is excused from its obligations under paragraph (b) of this clause. If the suspension or debarment official determines not to suspend or debar the Respondent, then the Respondent must reenroll in E-Verify.
 - iii. Web site. Information on registration for and use of the E-Verify program can be obtained via the Internet at the Department of Homeland Security Web site: <http://www.dhs.gov/E-Verify>.
Individuals previously verified. The Respondent is not required by this clause to perform additional employment verification using E-Verify for any employee-
 - (a) Whose employment eligibility was previously verified by the Respondent through the E-Verify program;
 - (b) Who has been granted and holds an active U.S. Government security clearance for access to confidential, secret, or top secret information in accordance with the National Industrial Security Program Operating Manual; or
 - (c) Who has undergone a completed background investigation and been issued credentials pursuant to Homeland Security Presidential Directive (HSPD)-12. Policy for a Common Identification Standard for Federal Employees and Respondents.

Subcontracts. The Respondent shall include the requirements of this clause, including this paragraph € (appropriately modified for identification of the parties in each subcontract that-

- (1) Is for-(i) Commercial and noncommercial services (except for commercial services that are part of the purchase of a COTS item (or an item that would be a COTS item, but for minor modifications), performed by the COTS provider, and are normally provided for that COTS item); or
(ii) Construction;
- (2) Has a value of more than \$3,500; and
- (3) Includes work performed in the United States.

DRAFT CONTRACT

Please note: this contract is a draft for bidder to view and understand the County’s standard terms and conditions, it is subject to revisions. By submitting a bid/proposal bidder/respondent understands and acknowledges that the draft contract is not an offer. Bidders/respondents are not to sign this draft contract.

EXHIBIT “A”

To be inserted later once submittals have been made- Initiation to Bid and Respondents Acknowledgement solicited for **Emerald Coast Convention Center Restroom Renovations and Meeting Room Counters** date of opening **August 28, 2019 at 3:00 P.M.** and any addendums thereto.

CONTRACT

For ITB TDD 49-19

Emerald Coast Convention Center Restroom Renovations and Meeting Room Counters

This Contract executed and entered into this ____ day of _____, 2019, between **Okaloosa County, Florida**, (hereinafter the “County”), whose principal address is 1250 N. Eglin Parkway, Shalimar, Florida 32579, and _____ (hereinafter the “Contractor”), whose principal address is _____ states as follows:

WITNESSETH:

WHEREAS, the County through an Invitation to Bid has solicited for the **Emerald Coast Convention Center Restroom Renovations and Meeting Room Counters**; and

WHEREAS, after due review of all bids, Contractor has been selected for the **Emerald Coast Convention Center Restroom Renovations and Meeting Room Counters**; and

WHEREAS, the County, as a recipient of federal assistance, is required to incorporate specific provisions in all contracts, regardless of funding source, with additional provisions being required for federally funded projects. These provisions are being incorporated per this amendment as stated in Exhibit “B “attached hereto; and

WHEREAS, the County desires the services of the Contractor and the Contractor is willing and able to perform all services in accordance with this Contract.

NOW, THEREFORE, the parties hereto agree as follows:

I. Incorporation of Documents

The following documents are incorporated herein by reference into this Contract and are attached as:

1. Exhibit "A", Invitation to Bid & Respondent's Acknowledgment/Contractor's Submittal, **ITB TDD 49-19, Emerald Coast Convention Center Restroom Renovations and Meeting Room Counters** date of opening August **28, 2019** and any addendums thereto.
2. Exhibit "B", Federal Regulations, attached hereto and made a part of the contract.

All terms within the above referenced documents are in full force and effect and shall be binding upon both parties.

II. Scope of Work

The Contractor will Remodel and renovate bathrooms and meeting room counters, as further outlined in the attached Exhibit "A". Any changes to the Contract shall be by a contract amendment, which must be agreed to in writing and fully executed by both parties.

III. Payment

The Contractor will be paid upon, receipt of goods or services and submission of a proper invoice, through the requesting Department on a monthly basis:

IV. Invoice Requirements

The Contractor shall request payment through submission of a properly completed invoice. County shall make payments within thirty (30) days of invoice date.

In the event a portion of an invoice submitted to the County for payment to the Contractor, as specified above, is disputed, payment for the disputed amount may be withheld pending resolution of the dispute, and the remainder of the invoice will be processed for payment without regard to that portion which is in dispute.

V. Duration of Contract and Termination of the Contract

The Contract will be effective when all parties have signed and will continue through completion, inspection and acceptance of project. The total number of days to substantial completion the project is anticipated to be two-hundred ten days (210) calendar days with the final completion date at two-hundred forty days (240).

The County may terminate the Contract with or without cause by providing thirty (30) days written notice to the Contractor. If terminated, Contractor shall be owed for services rendered and equipment provided up until the point of termination.

The County may terminate this Agreement in whole or part for cause, if the County determines that the performance of the Contractor is not satisfactory, the County shall notify the Contractor of the deficiency in writing with a requirement that the deficiency be corrected within ten (10) days of such notice. Such notice shall provide reasonable specificity to the Contractor of the deficiency that requires correction. If

the deficiency is not corrected within such time period, the County may either (1) immediately terminate the Agreement, or (2) take whatever action is deemed appropriate to correct the deficiency. In the event the County chooses to take action and not terminate the Agreement, the Contractor shall, upon demand, promptly reimburse the County for any and all costs and expenses incurred by the County in correcting the deficiency.

If the County terminates the Agreement, the County shall notify the Contractor of such termination in writing, with instruction to the effective date of termination or specify the stage of work at which the Agreement is to be terminated.

The County reserves the right to unilaterally cancel this Agreement immediately for refusal by the Contractor or any contractor, sub-contractor or materials vendor to allow public access to all documents, papers, letters or other material subject to the provisions of Chapter 119, Florida Statutes, and made or received in conjunction with this Agreement unless the records are exempt.

Upon receipt of a final termination or suspension notice under this Article, the Contractor shall proceed promptly to carry out the actions required in such notice, which may include any or all of the following:

1. Necessary action to terminate or suspend, as the case may be, Project activities and contracts and such other action as may be required or desirable to keep to a minimum the costs upon the basis of which the financing is to be computed; and
2. Furnish a statement of the activities and other undertakings the cost of which are otherwise includable as costs under this Agreement. The termination or suspension shall be carried out in conformity with the latest schedule of costs as approved by the County. The closing out of federal financial participation in the services provided shall not constitute a waiver of any claim which the County may otherwise have arising out of this Agreement.

VI. Remedies, Governing Law & Venue

This Contract shall be governed by the laws of the State of Florida. Any and all legal action necessary to enforce the Contract shall be held in the state courts of Okaloosa County, Florida. No remedy herein conferred upon any party is intended to be exclusive of any other remedy, and each and every such remedy shall be cumulative and shall be in addition to every other remedy given hereunder or now or hereafter existing at law or in equity or by statute or otherwise. No single or partial exercise by any party of any right, power, or remedy hereunder shall preclude any other or further exercise thereof.

VII. Intent of Contract Documents

It is the intent of the Contract Documents to describe a functionally complete project to be performed in accordance with the Contract Documents. Any work, materials or equipment that may reasonably be inferred from the Contract Documents as being required to produce the intended result shall be supplied whether or not specifically called for. When words that have a well-known technical or trade meaning are used to describe work, materials or equipment, such words shall be interpreted in accordance with that meaning. Reference to standard specifications, manuals or codes of any technical society, organization or association or to the laws or regulations of any governmental authority having jurisdiction over the Project, whether such reference be specific or by implication, shall mean the latest standard specification, manual, code, law or regulation in effect at the time the Work is performed, except as may be otherwise specifically stated herein.

VIII. Investigation

Contractor shall have the sole responsibility of satisfying itself concerning the nature and location of the Work and the general and local conditions, and particularly, but without limitation, with respect to the following: those affecting transportation, access, disposal, handling and storage of materials; availability and quality of labor; water and electric power; availability and condition of roads; work area; living facilities; climatic conditions and seasons; physical conditions at the work site and the project area as a whole; topography and ground surface conditions; nature and quantity of the surface materials to be encountered; subsurface conditions; equipment and facilities needed preliminary to and during performance of the Work; and all other costs associated with such performance. The failure of Contractor to acquaint itself with any applicable conditions shall not relieve Contractor from any of its responsibilities to perform under the Contract Documents, nor shall it be considered the basis for any claim for additional time or compensation.

IX. Notice

All notices required by this Contract shall be in writing to the representatives listed below:

The authorized representatives of the County shall be:

John Hofstad, County
Administrator 1250 North
Eglin Parkway, Suite 100
Shalimar, Florida, 32548
Phone: 850-651-7515
Fax: 850-651-7551
Email: jhofstad@myokaloosa.com

Allen Lassiter, Operations
Manager 1250 Miracle Strip
Parkway SE Fort Walton
Beach, FL 32548 Phone:
850-651-7160
Fax: 850-651-7164
Email: alassiter@myokaloosa.com

The authorized representative for the _____ shall be:

Courtesy copy to:

Okaloosa County Purchasing
Department
5479A Old Bethel Road
Crestview, FL 32536
Phone: 850-689-5960
Fax: 850-689-5998
Email: dmason@myokaloosa.com

Any party shall have the right, from time to time, to change the address to which notices shall be sent by giving the other party at least five (5) business days' prior notice of the address change.

X. Public Records

Any record created by either party in accordance with this Contract shall be retained and maintained in accordance with the public records law, Florida Statutes, Chapter 119.

IF THE CONTRACTOR HAS QUESTIONS REGARDING THE APPLICATION OF CHAPTER 119, FLORIDA STATUTES, TO THE CONTRACTOR'S DUTY TO PROVIDE PUBLIC RECORDS RELATING TO THIS CONTRACT, CONTACT THE CUSTODIAN OF PUBLIC RECORDS AT OKALOOSA COUNTY RISK MANAGEMENT DEPARTMENT 5479 OLD BETHEL ROAD CRESTVIEW, FL 32536, PHONE: (850) 689-5977 riskinfo@myokaloosa.com.

Contractor must comply with the public records laws, Florida Statute chapter 119, specifically Contractor must:

1. Keep and maintain public records required by the County to perform the service.
2. Upon request from the County's custodian of public records, provide the County with a copy of the requested records or allow the records to be inspected or copied within a reasonable time at a cost that does not exceed the cost provided in chapter 119 Florida Statutes or as otherwise provided by law.
3. Ensure that public records that are exempt or confidential and exempt from public records disclosure requirements are not disclosed except as authorized by law for the duration of the contract term and following completion of the contract if the contractor does not transfer the records to the County.
4. Upon completion of the contract, transfer, at no cost, to the County all public records in possession of the contractor or keep and maintain public records required by the County to perform the service. If the contractor transfers all public records to the public agency upon completion of the contract, the contractor shall destroy any duplicate public records that are exempt or confidential and exempt from public records disclosure requirements. If the contractor keeps and maintains public records upon completion of the contract, the contractor shall meet all applicable requirements for retaining the public records. All records stored electronically must be provided to the public agency, upon the request from the public agency's custodian of public records, in a format that is compatible with the information technology systems of the public agency.

XI. Audit

The County and/or its designee shall have the right from time to time at its sole expense to audit the compliance by the Contractor with the terms, conditions, obligations, limitations, restrictions, and requirements of this Contract and such right shall extend for a period of three (3) years after termination of this Contract.

XII. Assignment

Contractor shall not assign this Contract or any part thereof, without the prior consent in writing of the County. If Contractor does, with approval, assign this Contract or any part thereof, it shall require that its assignee be bound to it and to assume toward Contractor all of the obligations and responsibilities that Contractor has assumed toward the County.

XIII. Entire Contract & Waivers

This Contract and all exhibits as incorporated herein, contain the entire contract between the parties and supersedes all prior oral or written contracts. Contractor acknowledges that it has not relied upon any statement, representation, prior or contemporaneous written or oral promises, agreements or warranties, except such as are expressed herein. The terms and conditions of this Contract can only be amended in writing upon mutual agreement of the parties and signed by both parties.

The waiver by a party of any breach or default in performance shall not be deemed to constitute a waiver of any other or succeeding breach or default. The failure of the County to enforce any of the provisions hereof shall not be construed to be a waiver of the right of the County thereafter to enforce such provisions.

XIV. Severability

If any term or condition of this Contract shall be deemed, by a court having appropriate jurisdiction, invalid or unenforceable, the remainder of the terms and conditions of this Contract shall remain in full force and effect. This Contract shall not be more strictly construed against either party hereto by reason of the fact that one party may have drafted or prepared any or all the terms and provisions hereof.

XV. Independent Contractor

Contractor enters into this Contract as, and shall continue to be, an independent contractor. All services shall be performed only by Contractor and Contractor's employees. Under no circumstances shall Contractor or any of Contractor's employees look to the County as his/her employer, or as partner, agent or principal. Neither Contractor, nor any of Contractor's employees, shall be entitled to any benefits accorded to the County's employees, including without limitation worker's compensation, disability insurance, vacation or sick pay. Contractor shall be responsible for providing, at Contractor's expense, and in Contractor's name, unemployment, disability, worker's compensation and other insurance as well as licenses and permits usual and necessary for conducting the services to be provided under this Contract.

XVI. Third Party Beneficiaries

It is specifically agreed between the parties executing this Contract that it is not intended by any of the provisions of any part of the Contract to create in the public or any member thereof, a third party beneficiary under this Contract, or to authorize anyone not a party to this Contract to maintain a suit for personal injuries or property damage pursuant to the terms or provisions of this Contract.

XVII. Indemnification and Hold Harmless

Contractor agrees to hold harmless, indemnify, and defend or, at the option of the County, pay the cost of defense, the County and its representative from any and all claims, losses, penalties, demands, judgments, and costs of suit, including attorneys' fees and paralegals' fees, for any expense, damage or liability incurred by any of them, whether for personal injury, property damage, direct or consequential damages, or

economic loss, arising directly or indirectly on account of or in connection with the Work done by Contractor under this Contract or by any person, firm or corporation to whom any portion of the Work is subcontracted by Contractor or resulting from the use by Contractor, or by any one for whom Contractor is legally liable, of any materials, tools, machinery or other property of the County.

The Contractor's obligation under this provision shall not be limited in any way by the agreed upon contract price as shown in this contract or the Contractor's limit of, or lack of, sufficient insurance protection.

XVIII. Representation of Authority to Contractor/Signatory

The individual signing this Contract on behalf of Contractor represents and warrants that he or she is duly authorized and has legal capacity to execute and deliver this Contract. The signatory represents and warrants to the County that the execution and delivery of this Contract and the performance of Contractor obligations hereunder have been duly authorized and that the Contract is a valid and legal agreement binding on the Contractor and enforceable in accordance with its terms.

XIX. Subcontracting

Contractor shall not subcontract any services or work to be provided to County without the prior written approval of the County's Representative. The County reserves the right to accept the use of a subcontractor or to reject the selection of a particular subcontractor and to inspect all facilities of any subcontractors in order to make a determination as to the capability of the subcontractor to perform properly under this Contract. The County's acceptance of a subcontractor shall not be unreasonably withheld. The Contractor is encouraged to seek minority and women business enterprises for participation in subcontracting opportunities. Additionally, any subcontract entered into between the Contractor and subcontractor will need to be approved by the County prior to it being entered into, and said agreement shall incorporate in all required terms in accordance with local, state and Federal regulations.

XX. Insurance

BONDING REQUIREMENTS

- 1. Performance and Payment Bond:** The successful Respondent shall furnish to the County, without extra compensation, and shall maintain in effect throughout the life of the Contract, and for the duration of the period described in the bond, acceptable Performance and Payment bonds in sums at least equal to the full amount of the Contract, conditioned to indemnify and save harmless the County from and against any loss, damage, or expense ensuing from failure on the part of the Contractor to faithfully and properly perform the Contract or to promptly pay all its subcontractors, suppliers, material, men or laborers for work completed on the Project. The required forms for the performance and payment bonds are included herein.

If within ten (10) calendar days after the acceptance of the bid, the successful Respondent shall refuse or neglect to execute the contract and to furnish the required performance and payment bonds properly signed by the Respondent and the surety or sureties satisfactorily to the County, the Respondent shall be deemed to be in default and the County will retain the bid surety as liquidated damages, but not as a penalty. The County reserves the option to accept the bid of any of the other Respondents within ten (10) calendar days from default, in which case such acceptance shall have the same effect on such Respondent as though they were the original, successful Respondent.

CONTRACTORS INSURANCE

1. The Contractor shall not commence any work in connection with this Agreement until he has obtained all required insurance and such insurance has been approved by the Okaloosa County Risk Manager or designee.
2. All insurance policies shall be with insurers authorized to do business in the State of Florida.
3. All insurance shall include the interest of all entities named and their respective officials, employees & volunteers of each and all other interests as may be reasonably required by Okaloosa County. The coverage afforded the Additional Insured under this policy shall be primary insurance. If the Additional Insured have other insurance that is applicable to the loss, such other insurance shall be on an excess or contingent basis. The amount of the company's liability under this policy shall not be reduced by the existence of such other insurance.
4. Where applicable, the County shall be shown as an Additional Insured with a Waiver of Subrogation on the Certificate of Insurance.
5. The County shall retain the right to reject all insurance policies that do not meet the requirement of this Agreement. Further, the County reserves the right to change these insurance requirements with 60-day notice to the Contractor.
6. The County reserves the right at any time to require the Contractor to provide copies (redacted if necessary) of any insurance policies to document the insurance coverage specified in this Agreement.
7. The designation of Contractor shall include any associated or subsidiary company which is involved and is a part of the contract and such, if any associated or subsidiary company involved in the project must be named in the Workers' Compensation coverage.
8. Any exclusions or provisions in the insurance maintained by the Contractor that excludes coverage for work contemplated in this agreement shall be deemed unacceptable and shall be considered breach of contract.

WORKERS' COMPENSATION INSURANCE

1. The Contractor shall secure and maintain during the life of this Agreement Workers' Compensation insurance for all of his employees employed for the project or any site connected with the work, including supervision, administration or management, of this project and in case any work is sublet, with the approval of the County, the Contractor shall require the Subcontractor similarly to provide Workers' Compensation insurance for all employees employed at the site of the project, and such evidence of insurance shall be furnished to the County not less than ten (10) days prior to the commencement of any and all sub-contractual Agreements which have been approved by the County.

2. Contractor must be in compliance with all applicable State and Federal workers' compensation laws, including the U.S. Longshore Harbor Workers' Act or Jones Act, if applicable.
3. No class of employee, including the Contractor himself, shall be excluded from the Workers' Compensation insurance coverage. The Workers' Compensation insurance shall also include Employer's Liability coverage.

BUSINESS AUTOMOBILE LIABILITY

Coverage must be afforded for all Owned, Hired, Scheduled, and Non-Owned vehicles for Bodily Injury and Property Damage in an amount not less than \$1,000,000 combined single limit each accident. If the contractor does not own vehicles, the contractor shall maintain coverage for Hired & Non-Owned Auto Liability, which may be satisfied by way of endorsement to the Commercial General Liability policy or separate Business Auto Policy. Contractor must maintain this insurance coverage throughout the life of this Agreement.

COMMERCIAL GENERAL LIABILITY INSURANCE

1. The Contractor shall carry other Commercial General Liability insurance against all other Bodily Injury, Property Damage and Personal and Advertising Injury exposures.
2. All liability insurance (other than Professional Liability) shall be written on an occurrence basis and shall not be written on a claims-made basis. If the insurance is issued with an aggregate limit of liability, the aggregate limit of liability shall apply only to the locations included in this Agreement. If, as the result of any claims or other reasons, the available limits of insurance reduce to less than those stated in the Limits of Liability, the Contractor shall notify the County representative in writing. The Contractor shall purchase additional liability insurance to maintain the requirements established in this Agreement. Umbrella or Excess Liability insurance can be purchased to meet the Limits of Liability specified in this Agreement.
3. Commercial General Liability coverage shall include the following:
 - 1.) Premises & Operations Liability
 - 2.) Bodily Injury and Property Damage Liability
 - 3.) Independent Contractors Liability
 - 4.) Contractual Liability
 - 5.) Products and Completed Operations Liability
4. Contractor shall agree to keep in continuous force Commercial General Liability coverage for the length of the contract.

LIMITS OF LIABILITY

The insurance required shall be written for not less than the following, or greater if required by law and shall include Employer’s liability with limits as prescribed in this contract:

	<u>LIMIT</u>
1. Worker’s Compensation	
1.) State	Statutory
2.) Employer’s Liability	\$500,000 each accident
2. Business Automobile	\$1,000,000 each accident (A combined single limit)
3. Commercial General Liability	\$1,000,000 each occurrence for Bodily Injury & Property Damage \$1,000,000 each occurrence Products and completed operations
4. Personal and Advertising Injury	\$1,000,000 each occurrence

NOTICE OF CLAIMS OR LITIGATION

The Contractor agrees to report any incident or claim that results from performance of this Agreement. The County representative shall receive written notice in the form of a detailed written report describing the incident or claim within ten (10) days of the Contractor’s knowledge. In the event such incident or claim involves injury and/or property damage to a third party, verbal notification shall be given the same day the Contractor becomes aware of the incident or claim followed by a written detailed report within ten (10) days of verbal notification.

INDEMNIFICATION & HOLD HARMLESS

Contractor shall indemnify and hold harmless the County, its officers and employees from liabilities, damages, losses, and costs including but not limited to reasonable attorney fees, to the extent caused by the negligence, recklessness, or wrongful conduct of the Contractor and other persons employed or utilized by the Contractor in the performance of this contract.

Note: For Contractor’s convenience, this certification form is enclosed and is made a part of the bid package.

CERTIFICATE OF INSURANCE

1. Certificates of insurance indicating the job site and evidencing all required coverage must be submitted not less than 10 days prior to the commencement of any of the work. The certificate holder(s) shall be as follows: Okaloosa County, 5479A Old Bethel Road, Crestview, Florida, 32536.
2. The contractor shall provide a Certificate of Insurance to the County with a thirty (30) day

notice of cancellation; ten (10) days' notice if cancellation is for nonpayment of premium.

3. In the event that the insurer is unable to accommodate the cancellation notice requirement, it shall be the responsibility of the contractor to provide the proper notice. Such notification shall be in writing by registered mail, return receipt requested, and addressed to the Okaloosa County Purchasing Department at 5479-A Old Bethel Road, Crestview, FL 32536.
4. In the event the contract term goes beyond the expiration date of the insurance policy, the contractor shall provide the County with an updated Certificate of insurance no later than ten (10) days prior to the expiration of the insurance currently in effect. The County reserves the right to suspend the contract until this requirement is met.
5. The certificate shall indicate if coverage is provided under a claims-made or occurrence form. If any coverage is provided on a claims-made form, the certificate will show a retroactive date, which should be the same date of the initial contract or prior.
6. All certificates shall be subject to Okaloosa County's approval of adequacy of protection and the satisfactory character of the Insurer.
7. All deductibles or SIRs, whether approved by Okaloosa County or not, shall be the Contractor's full responsibility. In particular, the Contractor shall afford full coverage as specified herein to entities listed as Additional Insured.
8. In no way will the entities listed as Additional Insured be responsible for, pay for, be damaged by, or limited to coverage required by this schedule due to the existence of a deductible or SIR.

GENERAL TERMS

Any type of insurance or increase of limits of liability not described above which, the Contractor required for its own protection or on account of statute shall be its own responsibility and at its own expense.

Any exclusions or provisions in the insurance maintained by the contractor that excludes coverage for work contemplated in this contract shall be deemed unacceptable and shall be considered breach of contract.

The carrying of the insurance described shall in no way be interpreted as relieving the Contractor of any responsibility under this contract.

Should the Contractor engage a subcontractor or sub-subcontractor, the same conditions will apply under this Agreement to each subcontractor and sub-subcontractor.

The Contractor hereby waives all rights of subrogation against Okaloosa County and its consultants and other indemnities of the Contractor under all the foregoing policies of insurance.

UMBRELLA INSURANCE

The Contractor shall have the right to meet the liability insurance requirements with the purchase of an umbrella insurance policy. In all instances, the combination of primary and umbrella liability coverage must equal or exceed the minimum liability insurance limits stated in this Agreement. Okaloosa County will be listed as an additional insured with a waiver of subrogation.

XXI. Taxes and Assessments

Contractor agrees to pay all sales, use, or other taxes, assessments and other similar charges when due now or in the future, required by any local, state or federal law, including but not limited to such taxes and assessments as may from time to time be imposed by the County in accordance with this Agreement. Contractor further agrees that it shall protect, reimburse and indemnify County from and assume all liability for its tax and assessment obligations under the terms of the Agreement.

The County is exempt from payment of Florida state sales and use taxes. The Contractor shall not be exempted from paying sales tax to its suppliers for materials used to fulfill contractual obligations with the County, nor is the Contractor authorized to use the County's tax exemption number in securing such materials.

The Contractor shall be responsible for payment of its own and its share of its employees' payroll, payroll taxes, and benefits with respect to this Agreement.

XXII. Compliance with Laws

Contractor shall secure any and all permits, licenses and approvals that may be required in order to perform the Work, shall exercise full and complete authority over Contractor's personnel, shall comply with all workers' compensation, employer's liability and all other federal, state, county, and municipal laws, ordinances, rules and regulations required of an employer performing services such as the Work, and shall make all reports and remit all withholdings or other deductions from the compensation paid to Contractor's personnel as may be required by any federal, state, county, or municipal law, ordinance, rule, or regulation.

XXIII. Federal Regulations

The contractor agrees to comply with all federal, state and local laws, rules and regulations, including but not limited to, those set forth in Exhibit "B", which is expressly incorporated herein as a part of this contract.

XXIV. Vendors on the Scrutinized Companies Lists

By executing this Agreement, the Contractor, certifies that it is not: (1) listed on the Scrutinized Companies that Boycott Israel List, created pursuant to section 215.4725, Florida Statutes, (2) engaged in a boycott of Israel, (3) listed on the Scrutinized Companies with Activities in Sudan List or the Scrutinized Companies with Activities in the Iran Petroleum Energy Sector List, created pursuant to section 215.473, Florida Statutes, or (4) engaged in business operations in Cuba or Syria. Pursuant to section 287.135(5), Florida Statutes, the County may immediately terminate this Agreement for cause if the Contractor is found to have submitted a false certification as to the above or if the Contractor is placed on the Scrutinized Companies that Boycott Israel List, is engaged in a boycott of Israel, has been placed on the Scrutinized Companies with Activities in Sudan List or the Scrutinized Companies with Activities in the Iran Petroleum Energy Sector List, or has been engaged in business operations in Cuba or Syria, during the term of the Agreement. If the County determines that the Contractor has submitted a false certification, the County will provide written

notice to the Contractor. Unless the Contractor demonstrates in writing, within 90 calendar days of receipt of the notice, that the County's determination of false certification was made in error, the County shall bring a civil action against the Contractor. If the County's determination is upheld, a civil penalty equal to the greater of \$2 million or twice the amount of this Agreement shall be imposed on the Contractor, and the Contractor will be ineligible to bid on any Agreement with a Florida agency or local governmental entity for three years after the date of County's determination of false certification by Contractor. If federal law ceases to authorize the states to adopt and enforce the contracting prohibition identified in this Section XXIV, this Section XXIV shall be null and void

IN WITNESS WHEREOF, the parties hereto have made and executed this Contract on the respective dates under each signature.

Contractor

OKALOOSA COUNTY, FLORIDA

Printed Name/Title

Charles K. Windes, Jr., Chairman

Signature

Date: ___/___/___

Date:

ATTEST:

J.D. Peacock II, Clerk

Standard Contract Clauses

Exhibit “B”

Title VI Clauses for Compliance with Nondiscrimination Requirements

Compliance with Nondiscrimination Requirements

During the performance of this contract, the contractor, for itself, its assignees, and successors in interest (hereinafter referred to as the “contractor”) agrees as follows:

1. **Compliance with Regulations:** The contractor (hereinafter includes consultants) will comply with the Title VI List of Pertinent Nondiscrimination Acts And Authorities, as they may be amended from time to time, which are herein incorporated by reference and made a part of this contract.
2. **Non-discrimination:** The contractor, with regard to the work performed by it during the contract, will not discriminate on the grounds of race, color, or national origin in the selection and retention of subcontractors, including procurements of materials and leases of equipment. The contractor will not participate directly or indirectly in the discrimination prohibited by the Nondiscrimination Acts and Authorities, including employment practices when the contract covers any activity, project, or program set forth in Appendix B of 49 CFR part 21.
3. **Solicitations for Subcontracts, Including Procurements of Materials and Equipment:** The contract acknowledges that each potential subcontractor or supplier will be notified by the contractor of the contractor’s obligations under this contract and the Nondiscrimination Acts And Authorities on the grounds of race, color, or national origin.
4. **Information and Reports:** The contractor will provide all information and reports required by the Acts, the Regulations, and directives issued pursuant thereto and will permit access to its books, records, accounts, other sources of information, and its facilities as may be determined by the County or the Federal Aviation Administration to be pertinent to ascertain compliance with such Nondiscrimination Acts And Authorities and instructions. Where any information required of a contractor is in the exclusive possession of another who fails or refuses to furnish the information, the contractor will so certify to the sponsor or the Federal Aviation Administration, as appropriate, and will set forth what efforts it has made to obtain the information.

5. **Sanctions for Noncompliance:** In the event of a contractor's noncompliance with the Non-discrimination provisions of this contract, the sponsor will impose such contract sanctions as it or the Federal Aviation Administration may determine to be appropriate, including, but not limited to:
 - a. Withholding payments to the contractor under the contract until the contractor complies; and/or
 - b. Cancelling, terminating, or suspending a contract, in whole or in part.
6. **Incorporation of Provisions:** The contractor will include the provisions of paragraphs one through six in every subcontract, including procurements of materials and leases of equipment, unless exempt by the Acts, the Regulations and directives issued pursuant thereto. The contractor will take action with respect to any subcontract or procurement as the sponsor or the Federal Aviation Administration may direct as a means of enforcing such provisions including sanctions for noncompliance. Provided, that if the contractor becomes involved in, or is threatened with litigation by a subcontractor, or supplier because of such direction, the contractor may request the sponsor to enter into any litigation to protect the interests of the sponsor. In addition, the contractor may request the United States to enter into the litigation to protect the interests of the United States.

Title VI List of Pertinent Nondiscrimination Acts and Authorities

Title VI List of Pertinent Nondiscrimination Acts and Authorities

During the performance of this contract, the contractor, for itself, its assignees, and successors in interest (hereinafter referred to as the "contractor") agrees to comply with the following non-discrimination statutes and authorities; including but not limited to:

- Title VI of the Civil Rights Act of 1964 (42 U.S.C. § 2000d *et seq.*, 78 stat. 252), (prohibits discrimination on the basis of race, color, national origin);
- 49 CFR part 21 (Non-discrimination In Federally-Assisted Programs of The Department of Transportation—Effectuation of Title VI of The Civil Rights Act of 1964);
- The Uniform Relocation Assistance and Real Property Acquisition Policies Act of 1970, (42 U.S.C. § 4601), (prohibits unfair treatment of persons displaced or whose property has been acquired because of Federal or Federal-aid programs and projects);
- Section 504 of the Rehabilitation Act of 1973, (29 U.S.C. § 794 *et seq.*), as amended, (prohibits discrimination on the basis of disability); and 49 CFR part 27;

- The Age Discrimination Act of 1975, as amended, (42 U.S.C. § 6101 *et seq.*), (prohibits discrimination on the basis of age);
- Airport and Airway Improvement Act of 1982, (49 USC § 471, Section 47123), as amended, (prohibits discrimination based on race, creed, color, national origin, or sex);
- The Civil Rights Restoration Act of 1987, (PL 100-209), (Broadened the scope, coverage and applicability of Title VI of the Civil Rights Act of 1964, The Age Discrimination Act of 1975 and Section 504 of the Rehabilitation Act of 1973, by expanding the definition of the terms “programs or activities” to include all of the programs or activities of the Federal-aid recipients, sub-recipients and contractors, whether such programs or activities are Federally funded or not);
- Titles II and III of the Americans with Disabilities Act of 1990, which prohibit discrimination on the basis of disability in the operation of public entities, public and private transportation systems, places of public accommodation, and certain testing entities (42 U.S.C. §§ 12131 – 12189) as implemented by Department of Transportation regulations at 49 CFR parts 37 and 38;
- The Federal Aviation Administration’s Non-discrimination statute (49 U.S.C. § 47123) (prohibits discrimination on the basis of race, color, national origin, and sex);
- Executive Order 12898, Federal Actions to Address Environmental Justice in Minority Populations and Low-Income Populations, which ensures non-discrimination against minority populations by discouraging programs, policies, and activities with disproportionately high and adverse human health or environmental effects on minority and low-income populations;
- Executive Order 13166, Improving Access to Services for Persons with Limited English Proficiency, and resulting agency guidance, national origin discrimination includes discrimination because of limited English proficiency (LEP). To ensure compliance with Title VI, you must take reasonable steps to ensure that LEP persons have meaningful access to your programs (70 Fed. Reg. at 74087 to 74100);
- Title IX of the Education Amendments of 1972, as amended, which prohibits you from discriminating because of sex in education programs or activities (20 U.S.C. 1681 *et seq.*).

FEDERAL FAIR LABOR STANDARDS ACT (FEDERAL MINIMUM WAGE)

All contracts and subcontracts that result from this solicitation incorporate by reference the provisions of 29 CFR part 201, the Federal Fair Labor Standards Act (FLSA), with the same force and effect as if given in full text. The FLSA sets minimum wage, overtime pay, recordkeeping, and child labor standards for full and part time workers.

The [*contractor / consultant*] has full responsibility to monitor compliance to the referenced statute or regulation. The [*contractor / consultant*] must address any claims or disputes that arise from this requirement directly with the U.S. Department of Labor – Wage and Hour Division

OCCUPATIONAL SAFETY AND HEALTH ACT O F 197 0

All contracts and subcontracts that result from this solicitation incorporate by reference the requirements of 29 CFR Part 1910 with the same force and effect as if given in full text. Contractor must provide a work environment that is free from recognized hazards that may cause death or serious physical harm to the employee. The Contractor retains full responsibility to monitor its compliance and their subcontractor's compliance with the applicable requirements of the Occupational Safety and Health Act of 1970 (20 CFR Part 1910). Contractor must address any claims or disputes that pertain to a referenced requirement directly with the U.S. Department of Labor – Occupational Safety and Health Administration.

E-VERIFY

Enrollment and verification requirements.

- (1) If the Contractor is not enrolled as a Federal Contractor in E-Verify at time of contract award, the Contractor shall-
 - a. Enroll. Enroll as a Federal Contractor in the E-Verify Program within thirty (30) calendar days of contract award;
 - b. Verify all new employees. Within ninety (90) calendar days of enrollment in the E-Verify program, begin to use E-Verify to initiate verification of employment eligibility of all new hires of the Contractor, who are working in the United States, whether or not assigned to the contract, within three (3) business days after the date of hire (but see paragraph (b)(3) of this section); and,
 - c. Verify employees assigned to the contract. For each employee assigned to the contract, initiate verification within ninety (90) calendar days after date of enrollment or within thirty (30) calendar days of the employee's assignment to the contract, whichever date is later (but see paragraph (b)(4) of this section.)
- (2) If the Contractor is enrolled as a Federal Contractor in E-Verify at time of contract award, the Contractor shall use E-Verify to initiate verification of employment eligibility of
 - a. All new employees.

- i. Enrolled ninety (90) calendar days or more. The Contractor shall initiate verification of all new hires of the Contractor, who are working in the United States, whether or not assigned to the contract, within three (3) business days after the date of hire (but see paragraph (b)(3) of this section); or
 - b. Enrolled less than ninety (90) calendar days. Within ninety (90) calendar days after enrollment as a Federal Contractor in E-Verify, the Contractor shall initiate verification of all new hires of the contractor, who are working in the United States, whether or not assigned to the contract, within three (3) business days after the date of hire (but see paragraph (b)(3) of this section; or
 - ii. Employees assigned to the contract. For each employee assigned to the contract, the Contractor shall initiate verification within ninety (90) calendar days after date of contract award or within thirty (30) days after assignment to the contract, whichever date is later (but see paragraph (b)(4) of this section.)
- (3) If the Contractor is an institution of higher education (as defined at 20 U.S.C. 1001(a)); a State or local government or the government of a Federally recognized Indian tribe, or a surety performing under a takeover agreement entered into with a Federal agency pursuant to a performance bond, the Contractor may choose to verify only employees assigned to the contract, whether existing employees or new hires. The Contractor shall follow the applicable verification requirements of (b)(1) or (b)(2), respectively, except that any requirement for verification of new employees applies only to new employees assigned to the contract.
- (4) Option to verify employment eligibility of all employees. The Contractor may elect to verify all existing employees hired after November 6, 1986 (after November 27, 2009, in the Commonwealth of the Northern Mariana Islands), rather than just those employees assigned to the contract. The Contractor shall initiate verification for each existing employee working in the United States who was hired after November 6, 1986 (after November 27, 2009, in the Commonwealth of the Northern Mariana Islands), within one hundred eighty (180) calendar days of-
 - i. Enrollment in the E-Verify program; or
 - ii. Notification to E-Verify Operations of the Contractor's decision to exercise this option, using the contract information provided in the E-Verify program Memorandum of Understanding (MOU)
- (5) The Contractor shall comply, for the period of performance of this contract, with the

requirements of the E-Verify program MOU.

i. The Department of Homeland Security (DHS) or the Social Security Administration (SSA) may terminate the Contractor's MOU and deny access to the E-Verify system in accordance with the terms of the MOU. In such case, the Contractor, will be referred to a suspension or debarment official.

ii. During the period between termination of the MOU and a decision by the suspension or debarment official whether to suspend or debar, the contractor is excused from its obligations under paragraph (b) of this clause. If the suspension or debarment official determines not to suspend or debar the Contractor, then the Contractor must reenroll in E-Verify.

iii. Web site. Information on registration for and use of the E-Verify program can be obtained via the Internet at the Department of Homeland Security Web site: <http://www.dhs.gov/E-Verify>.

Individuals previously verified. The Contractor is not required by this clause to perform additional employment verification using E-Verify for any employee-

- (a) Whose employment eligibility was previously verified by the Contractor through the E-Verify program;
- (b) Who has been granted and holds an active U.S. Government security clearance for access to confidential, secret, or top secret information in accordance with the National Industrial Security Program Operating Manual; or
- (c) Who has undergone a completed background investigation and been issued credentials pursuant to Homeland Security Presidential Directive (HSPD)-12. Policy for a Common Identification Standard for Federal Employees and Contractors.

Subcontracts. The Contractor shall include the requirements of this clause, including this paragraph € (appropriately modified for identification of the parties in each subcontract that-

- (1) Is for-(i) Commercial and noncommercial services (except for commercial services that are part of the purchase of a COTS item (or an item that would be a COTS item, but for minor modifications), performed by the COTS provider, and are normally provided for that COTS item); or (ii) Construction;
- (2) Has a value of more than \$3,500; and Includes work performed in the United States.

EMERALD COAST CONVENTION CENTER

RESTROOM RENOVATIONS AND
MEETING ROOM COUNTERS
FORT WALTON BEACH, FLORIDA

PROJECT MANUAL

January 2019



Project Consultant



**Okaloosa County TDC – Emerald Coast Convention Center
Restroom Renovations and Meeting Room Counters**

TABLE OF CONTENTS

DIVISION 01 – GENERAL REQUIREMENTS

- 01 00 00 Summary
- 01 25 00 Substitution Procedures
- 01 26 00 Contract Modification Procedures
- 01 31 00 Project Management and Coordination
- 01 50 00 Temporary Facilities and Controls
- 01 60 00 Product Requirements
- 01 73 00 Execution

DIVISION 02 – EXISTING CONDITIONS

- 02 41 19 Selective Demolition

DIVISION 07 – THERMAL AND MOISTURE PROTECTION

- 07 21 00 Thermal Insulation
- 07 21 19 Foamed-In-Place Insulation
- 07 90 00 Joint Sealants

DIVISION 08 – OPENINGS

- 08 11 13 Hollow Metal Doors and Frames
- 08 14 16 Flush Wood Doors
- 08 31 13 Access Doors and Frames
- 08 71 00 Door Hardware

DIVISION 09 – FINISHES

- 09 22 16 Non-Structural Metal Framing
- 09 29 00 Gypsum Board
- 09 30 13 Ceramic Tiling
- 09 31 23 Thin-Set Glass Mosaic Tiling
- 09 99 23 Interior Painting

DIVISION 10 – SPECIALTIES

- 10 21 13.40 Stone Toilet Compartments
- 10 25 19 Modular Integrated Lavatory System

DIVISION 26 - ELECTRICAL

- 26 05 00 Electrical General Requirements
- 26 05 10 Electric Methods and Basic Materials
- 26 05 19 Low Voltage Electrical Power Conductors & Cables

**Okaloosa County TDC – Emerald Coast Convention Center
Restroom Renovations and Meeting Room Counters**

26 05 23	Firestop Systems and Sleeves
26 05 26	Grounding and Bonding for Electrical Systems
26 05 29	Electrical Supports
26 05 33	Raceways and Boxes for Electrical Systems
26 05 53	Identification for Electrical Systems
26 09 23	Lighting Controls and Devices
26 27 26	Wiring Devices
26 51 00	Interior Lighting

**Okaloosa County TDC – Emerald Coast Convention Center
Restroom Renovations and Meeting Room Counters**

SECTION 011000 - SUMMARY

PART 1 - GENERAL

1.1 SUMMARY

A. Section Includes:

1. Project information.
2. Work covered by Contract Documents.
3. Phased construction.
4. Access to site.
5. Coordination with occupants.
6. Work restrictions.

B. Related Requirements:

1. Section 015000 "Temporary Facilities and Controls" for limitations and procedures governing temporary use of Owner's facilities.

1.2 PROJECT INFORMATION

A. Project Identification: Emerald Coast Convention Center - Restroom Renovations and Meeting Room Counters.

1. Project Location: Emerald Coast Convention Center – 1250 Miracle Strip Parkway SE, Fort Walton Beach, Florida 32548.

B. Owner: Okaloosa County.

1. Owner's Representative: Jeffrey A. Hyde, Purchasing Manager, Okaloosa County Purchasing.

C. Architect: DAG Architects Inc. Destin, Florida.

1.3 WORK COVERED BY CONTRACT DOCUMENTS

A. The Work of Project is defined by the Contract Documents and consists of the following:

1. Renovate six (6) existing public restrooms, replace nine (9) meeting room service counters and other Work indicated in the Contract Documents.

B. Type of Contract:

1. Project will be constructed under a single prime contract.

**Okaloosa County TDC – Emerald Coast Convention Center
Restroom Renovations and Meeting Room Counters**

1.4 PHASED CONSTRUCTION

- A. The Work shall be conducted in 3 phases, with each phase substantially complete as indicated.
- B. Before commencing Work of each phase, submit an updated copy of Contractor's construction schedule showing the sequence, commencement and completion dates for all phases of the Work.

1.5 ACCESS TO SITE

- A. General: Contractor shall have limited use of Project site for construction operations as indicated on Drawings by the Contract limits and as indicated by requirements of this Section.
- B. Use of Site: Limit use of Project site to Work in areas indicated. Do not disturb portions of Project site beyond areas in which the Work is indicated.
 - 1. Driveways, Walkways, and Entrances: Keep driveways, parking garage, loading areas, and entrances serving premises clear and available to Owner, Owner's employees, and emergency vehicles at all times. Do not use these areas for parking or for storage of materials.
- C. Condition of Existing Building: Maintain portions of existing building affected by construction operations in a weathertight condition throughout construction period. Repair damage caused by construction operations.

1.6 COORDINATION WITH OCCUPANTS

- A. Full Owner Occupancy: Owner will occupy site and existing buildings during entire construction period. Cooperate with Owner during construction operations to minimize conflicts and facilitate Owner usage. Perform the Work so as not to interfere with Owner's day-to-day operations. Maintain existing exits unless otherwise indicated.

1.7 WORK RESTRICTIONS

- A. Work Restrictions, General: Comply with restrictions on construction operations.
 - 1. Comply with limitations on use of public streets and with other requirements of authorities having jurisdiction.
- B. Existing Utility Interruptions: Do not interrupt utilities serving facilities occupied by Owner or others unless permitted under the following conditions and then only after providing temporary utility services according to requirements indicated:
 - 1. Notify Owner not less than two days in advance of proposed utility interruptions.
 - 2. Obtain Owner's written permission before proceeding with utility interruptions.

**Okaloosa County TDC – Emerald Coast Convention Center
Restroom Renovations and Meeting Room Counters**

- C. Restricted Substances: Use of tobacco products and other controlled substances within the existing building is not permitted.

1.8 SPECIFICATION AND DRAWING CONVENTIONS

- A. Specification Content: The Specifications use certain conventions for the style of language and the intended meaning of certain terms, words, and phrases when used in particular situations. These conventions are as follows:
 - 1. Imperative mood and streamlined language are generally used in the Specifications. The words "shall," "shall be," or "shall comply with," depending on the context, are implied where a colon (:) is used within a sentence or phrase.
 - 2. Specification requirements are to be performed by Contractor unless specifically stated otherwise.
- B. Division 01 General Requirements: Requirements of Sections in Division 01 apply to the Work of all Sections in the Specifications.

PART 2 - PRODUCTS (Not Used)

PART 3 - EXECUTION (Not Used)

END OF SECTION 011000

**Okaloosa County TDC – Emerald Coast Convention Center
Restroom Renovations and Meeting Room Counters**

Page Left Blank

**Okaloosa County TDC – Emerald Coast Convention Center
Restroom Renovations and Meeting Room Counters**

SECTION 012500 - SUBSTITUTION PROCEDURES

PART 1 - GENERAL

1.1 SUMMARY

- A. Section includes administrative and procedural requirements for substitutions.
- B. Related Requirements:
 - 1. Section 016000 "Product Requirements" for requirements for submitting comparable product submittals for products by listed manufacturers.

1.2 DEFINITIONS

- A. Substitutions: Changes in products, materials, equipment, and methods of construction from those required by the Contract Documents and proposed by Contractor.
 - 1. Substitutions for Cause: Changes proposed by Contractor that are required due to changed Project conditions, such as unavailability of product, regulatory changes, or unavailability of required warranty terms.
 - 2. Substitutions for Convenience: Changes proposed by Contractor or Owner that are not required in order to meet other Project requirements but may offer advantage to Contractor or Owner.

1.3 ACTION SUBMITTALS

- A. Substitution Requests: Submit three copies of each request for consideration. Identify product or fabrication or installation method to be replaced. Include Specification Section number and title and Drawing numbers and titles.
 - 1. Documentation: Show compliance with requirements for substitutions and the following, as applicable:
 - a. Statement indicating why specified product or fabrication or installation method cannot be provided, if applicable.
 - b. Coordination of information, including a list of changes or revisions needed to other parts of the Work and to construction performed by Owner and separate contractors that will be necessary to accommodate proposed substitution.
 - c. Detailed comparison of significant qualities of proposed substitutions with those of the Work specified. Include annotated copy of applicable Specification Section. Significant qualities may include attributes, such as performance, weight, size, durability, visual effect, sustainable design characteristics, warranties, and specific

**Okaloosa County TDC – Emerald Coast Convention Center
Restroom Renovations and Meeting Room Counters**

features and requirements indicated. Indicate deviations, if any, from the Work specified.

- d. Product Data, including drawings and descriptions of products and fabrication and installation procedures.
 - e. Samples, where applicable or requested.
 - f. Certificates and qualification data, where applicable or requested.
 - g. List of similar installations for completed projects, with project names and addresses as well as names and addresses of architects and owners.
 - h. Material test reports from a qualified testing agency, indicating and interpreting test results for compliance with requirements indicated.
 - i. Research reports evidencing compliance with building code in effect for Project.
 - j. Detailed comparison of Contractor's construction schedule using proposed substitutions with products specified for the Work, including effect on the overall Contract Time. If specified product or method of construction cannot be provided within the Contract Time, include letter from manufacturer, on manufacturer's letterhead, stating date of receipt of purchase order, lack of availability, or delays in delivery.
 - k. Cost information, including a proposal of change, if any, in the Contract Sum.
 - l. Contractor's certification that proposed substitution complies with requirements in the Contract Documents, except as indicated in substitution request, is compatible with related materials and is appropriate for applications indicated.
 - m. Contractor's waiver of rights to additional payment or time that may subsequently become necessary because of failure of proposed substitution to produce indicated results.
2. Architect's Action: If necessary, Architect will request additional information or documentation for evaluation within seven days of receipt of a request for substitution. Architect will notify Contractor of acceptance or rejection of proposed substitution within 15 days of receipt of request, or seven days of receipt of additional information or documentation, whichever is later.
- a. Forms of Acceptance: Change Order, Construction Change Directive, or Architect's Supplemental Instructions for minor changes in the Work.
 - b. Use product specified if Architect does not issue a decision on use of a proposed substitution within time allocated.

1.4 QUALITY ASSURANCE

- A. Compatibility of Substitutions: Investigate and document compatibility of proposed substitution with related products and materials. Engage a qualified testing agency to perform compatibility tests recommended by manufacturers.

1.5 PROCEDURES

- A. Coordination: Revise or adjust affected work as necessary to integrate work of the approved substitutions.

**Okaloosa County TDC – Emerald Coast Convention Center
Restroom Renovations and Meeting Room Counters**

1.6 SUBSTITUTIONS

- A. Substitutions for Cause: Submit requests for substitution immediately on discovery of need for change, but not later than 15 days prior to time required for preparation and review of related submittals.
1. Conditions: Architect will consider Contractor's request for substitution when the following conditions are satisfied. If the following conditions are not satisfied, Architect will return requests without action, except to record noncompliance with these requirements:
- a. Requested substitution is consistent with the Contract Documents and will produce indicated results.
 - b. Substitution request is fully documented and properly submitted.
 - c. Requested substitution will not adversely affect Contractor's construction schedule.
 - d. Requested substitution has received necessary approvals of authorities having jurisdiction.
 - e. Requested substitution is compatible with other portions of the Work.
 - f. Requested substitution has been coordinated with other portions of the Work.
 - g. Requested substitution provides specified warranty.
 - h. If requested substitution involves more than one contractor, requested substitution has been coordinated with other portions of the Work, is uniform and consistent, is compatible with other products, and is acceptable to all contractors involved.
- B. Substitutions for Convenience: Not allowed unless otherwise indicated.
- C. Substitutions for Convenience: Architect will consider requests for substitution if received within 60 days after the Notice to Proceed. Requests received after that time may be considered or rejected at discretion of Architect.
1. Conditions: Architect will consider Contractor's request for substitution when the following conditions are satisfied. If the following conditions are not satisfied, Architect will return requests without action, except to record noncompliance with these requirements:
- a. Requested substitution offers Owner a substantial advantage in cost, time, energy conservation, or other considerations, after deducting additional responsibilities Owner must assume. Owner's additional responsibilities may include compensation to Architect for redesign and evaluation services, increased cost of other construction by Owner, and similar considerations.
 - b. Requested substitution does not require extensive revisions to the Contract Documents.
 - c. Requested substitution is consistent with the Contract Documents and will produce indicated results.
 - d. Substitution request is fully documented and properly submitted.
 - e. Requested substitution will not adversely affect Contractor's construction schedule.
 - f. Requested substitution has received necessary approvals of authorities having jurisdiction.
 - g. Requested substitution is compatible with other portions of the Work.

**Okaloosa County TDC – Emerald Coast Convention Center
Restroom Renovations and Meeting Room Counters**

- h. Requested substitution has been coordinated with other portions of the Work.
- i. Requested substitution provides specified warranty.
- j. If requested substitution involves more than one contractor, requested substitution has been coordinated with other portions of the Work, is uniform and consistent, is compatible with other products, and is acceptable to all contractors involved.

PART 2 - PRODUCTS (Not Used)

PART 3 - EXECUTION (Not Used)

END OF SECTION 012500

**Okaloosa County TDC – Emerald Coast Convention Center
Restroom Renovations and Meeting Room Counters**

SECTION 012600 - CONTRACT MODIFICATION PROCEDURES

PART 1 - GENERAL

1.1 SUMMARY

- A. Section includes administrative and procedural requirements for handling and processing Contract modifications.

1.2 MINOR CHANGES IN THE WORK

- A. Architect will issue supplemental instructions authorizing minor changes in the Work, not involving adjustment to the Contract Sum or the Contract Time, on AIA Document G710.

1.3 PROPOSAL REQUESTS

- A. Owner-Initiated Proposal Requests: Architect will issue a detailed description of proposed changes in the Work that may require adjustment to the Contract Sum or the Contract Time. If necessary, the description will include supplemental or revised Drawings and Specifications.
 - 1. Work Change Proposal Requests issued by Architect are not instructions either to stop work in progress or to execute the proposed change.
 - 2. Within time specified in Proposal Request or 20 days, when not otherwise specified, after receipt of Proposal Request, submit a quotation estimating cost adjustments to the Contract Sum and the Contract Time necessary to execute the change.
 - a. Include a list of quantities of products required or eliminated and unit costs, with total amount of purchases and credits to be made. If requested, furnish survey data to substantiate quantities.
 - b. Indicate applicable taxes, delivery charges, equipment rental, and amounts of trade discounts.
 - c. Include costs of labor and supervision directly attributable to the change.
 - d. Include an updated Contractor's construction schedule that indicates the effect of the change, including, but not limited to, changes in activity duration, start and finish times, and activity relationship. Use available total float before requesting an extension of the Contract Time.
- B. Contractor-Initiated Proposals: If latent or changed conditions require modifications to the Contract, Contractor may initiate a claim by submitting a request for a change to Architect.
 - 1. Include a statement outlining reasons for the change and the effect of the change on the Work. Provide a complete description of the proposed change. Indicate the effect of the proposed change on the Contract Sum and the Contract Time.

**Okaloosa County TDC – Emerald Coast Convention Center
Restroom Renovations and Meeting Room Counters**

2. Include a list of quantities of products required or eliminated and unit costs, with total amount of purchases and credits to be made. If requested, furnish survey data to substantiate quantities.
3. Indicate applicable taxes, delivery charges, equipment rental, and amounts of trade discounts.
4. Include costs of labor and supervision directly attributable to the change.
5. Include an updated Contractor's construction schedule that indicates the effect of the change, including, but not limited to, changes in activity duration, start and finish times, and activity relationship. Use available total float before requesting an extension of the Contract Time.
6. Comply with requirements in Section 012500 "Substitution Procedures" if the proposed change requires substitution of one product or system for product or system specified.

1.4 CHANGE ORDER PROCEDURES

- A. On Owner's approval of a Work Change Proposal Request, Architect will issue a Change Order for signatures of Owner and Contractor on AIA Document G701.

1.5 CONSTRUCTION CHANGE DIRECTIVE

- A. Construction Change Directive: Architect may issue a Construction Change Directive on AIA Document G714. Construction Change Directive instructs Contractor to proceed with a change in the Work, for subsequent inclusion in a Change Order.
 1. Construction Change Directive contains a complete description of change in the Work. It also designates method to be followed to determine change in the Contract Sum or the Contract Time.
- B. Documentation: Maintain detailed records on a time and material basis of work required by the Construction Change Directive.
 1. After completion of change, submit an itemized account and supporting data necessary to substantiate cost and time adjustments to the Contract.

1.6 WORK CHANGE DIRECTIVE

- A. Work Change Directive: Architect may issue a Work Change Directive. Work Change Directive instructs Contractor to proceed with a change in the Work, for subsequent inclusion in a Change Order.
 1. Work Change Directive contains a complete description of change in the Work. It also designates method to be followed to determine change in the Contract Sum or the Contract Time.
- B. Documentation: Maintain detailed records on a time and material basis of work required by the Work Change Directive.

**Okaloosa County TDC – Emerald Coast Convention Center
Restroom Renovations and Meeting Room Counters**

1. After completion of change, submit an itemized account and supporting data necessary to substantiate cost and time adjustments to the Contract.

PART 2 - PRODUCTS (Not Used)

PART 3 - EXECUTION (Not Used)

END OF SECTION 012600

**Okaloosa County TDC – Emerald Coast Convention Center
Restroom Renovations and Meeting Room Counters**

Page left blank

**Okaloosa County TDC – Emerald Coast Convention Center
Restroom Renovations and Meeting Room Counters**

SECTION 013100 - PROJECT MANAGEMENT AND COORDINATION

PART 1 - GENERAL

1.1 RELATED DOCUMENTS

- A. Drawings and general provisions of the Contract, including General and Supplementary Conditions and other Division 01 Specification Sections, apply to this Section.

1.2 SUMMARY

- A. Section includes administrative provisions for coordinating construction operations on Project including, but not limited to, the following:
 - 1. General coordination procedures.
 - 2. Coordination drawings.
 - 3. RFIs.
 - 4. Digital project management procedures.
 - 5. Project meetings.
- B. Related Requirements:
 - 1. Section 017300 "Execution" for procedures for coordinating general installation and field-engineering services, including establishment of benchmarks and control points.

1.3 DEFINITIONS

- A. RFI: Request for Information. Request from Owner, Architect, or Contractor seeking information required by or clarifications of the Contract Documents.

1.4 INFORMATIONAL SUBMITTALS

- A. Subcontract List: Prepare a written summary identifying individuals or firms proposed for each portion of the Work, including those who are to furnish products or equipment fabricated to a special design. Include the following information in tabular form:
 - 1. Name, address, telephone number, and email address of entity performing subcontract or supplying products.
 - 2. Number and title of related Specification Section(s) covered by subcontract.
 - 3. Drawing number and detail references, as appropriate, covered by subcontract.

**Okaloosa County TDC – Emerald Coast Convention Center
Restroom Renovations and Meeting Room Counters**

1.5 GENERAL COORDINATION PROCEDURES

- A. Coordination: Coordinate construction operations included in different Sections of the Specifications to ensure efficient and orderly installation of each part of the Work. Coordinate construction operations included in different Sections that depend on each other for proper installation, connection, and operation.
1. Schedule construction operations in sequence required to obtain the best results where installation of one part of the Work depends on installation of other components, before or after its own installation.
 2. Coordinate installation of different components to ensure maximum performance and accessibility for required maintenance, service, and repair.
 3. Make adequate provisions to accommodate items scheduled for later installation.
- B. Administrative Procedures: Coordinate scheduling and timing of required administrative procedures with other construction activities to avoid conflicts and to ensure orderly progress of the Work. Such administrative activities include, but are not limited to, the following:
1. Preparation of Contractor's construction schedule.
 2. Preparation of the schedule of values.
 3. Installation and removal of temporary facilities and controls.
 4. Delivery and processing of submittals.
 5. Progress meetings.
 6. Preinstallation conferences.
 7. Project closeout activities.
 8. Startup and adjustment of systems.

1.6 COORDINATION DRAWINGS

- A. Coordination Drawings, General: Prepare coordination drawings according to requirements in individual Sections, and additionally where installation is not completely indicated on Shop Drawings, where limited space availability necessitates coordination, or if coordination is required to facilitate integration of products and materials fabricated or installed by more than one entity.
1. Content: Project-specific information, drawn accurately to a scale large enough to indicate and resolve conflicts. Do not base coordination drawings on standard printed data. Include the following information, as applicable:
 - a. Indicate functional and spatial relationships of components of architectural, structural, civil, mechanical, and electrical systems.
 - b. Indicate dimensions shown on Drawings. Specifically note dimensions that appear to be in conflict with submitted equipment and minimum clearance requirements. Provide alternative sketches to Architect indicating proposed resolution of such conflicts. Minor dimension changes and difficult installations will not be considered changes to the Contract.
- B. Coordination Drawing Organization: Organize coordination drawings as follows:

**Okaloosa County TDC – Emerald Coast Convention Center
Restroom Renovations and Meeting Room Counters**

1. Floor Plans and Reflected Ceiling Plans: Show architectural and structural elements, and mechanical, plumbing, fire-protection, fire-alarm, and electrical Work. Show locations of visible ceiling-mounted devices relative to acoustical ceiling grid. Supplement plan drawings with section drawings where required to adequately represent the Work.
2. Plenum Space: Indicate subframing for support of ceiling and wall systems, mechanical and electrical equipment, and related Work. Locate components within plenums to accommodate layout of light fixtures and other components indicated on Drawings. Indicate areas of conflict between light fixtures and other components.
3. Mechanical Rooms: Provide coordination drawings for mechanical rooms showing plans and elevations of mechanical, plumbing, fire-protection, fire-alarm, and electrical equipment.
4. Structural Penetrations: Indicate penetrations and openings required for all disciplines.
5. Slab Edge and Embedded Items: Indicate slab edge locations and sizes and locations of embedded items for metal fabrications, sleeves, anchor bolts, bearing plates, angles, door floor closers, slab depressions for floor finishes, curbs and housekeeping pads, and similar items.
6. Review: Architect will review coordination drawings to confirm that in general the Work is being coordinated, but not for the details of the coordination, which are Contractor's responsibility.

1.7 REQUEST FOR INFORMATION (RFI)

- A. General: Immediately on discovery of the need for additional information, clarification, or interpretation of the Contract Documents, Contractor shall prepare and submit an RFI in the form specified.
 1. Architect will return without response those RFIs submitted to Architect by other entities controlled by Contractor.
 2. Coordinate and submit RFIs in a prompt manner so as to avoid delays in Contractor's work or work of subcontractors.
- B. Content of the RFI: Include a detailed, legible description of item needing information or interpretation and the following:
 1. Project name.
 2. Project number.
 3. Date.
 4. Name of Contractor.
 5. Name of Architect.
 6. RFI number, numbered sequentially.
 7. RFI subject.
 8. Specification Section number and title and related paragraphs, as appropriate.
 9. Drawing number and detail references, as appropriate.
 10. Field dimensions and conditions, as appropriate.
 11. Contractor's suggested resolution. If Contractor's suggested resolution impacts the Contract Time or the Contract Sum, Contractor shall state impact in the RFI.
 12. Contractor's signature.

**Okaloosa County TDC – Emerald Coast Convention Center
Restroom Renovations and Meeting Room Counters**

13. Attachments: Include sketches, descriptions, measurements, photos, Product Data, Shop Drawings, coordination drawings, and other information necessary to fully describe items needing interpretation.
- C. RFI Forms: AIA Document G716 or software-generated form with substantially the same content as indicated above, acceptable to Architect].
- D. Architect's Action: Architect will review each RFI, determine action required, and respond. Allow seven working days for Architect's response for each RFI. RFIs received by Architect after 1:00 p.m. will be considered as received the following working day.
 1. The following Contractor-generated RFIs will be returned without action:
 - a. Requests for approval of submittals.
 - b. Requests for approval of substitutions.
 - c. Requests for approval of Contractor's means and methods.
 - d. Requests for coordination information already indicated in the Contract Documents.
 - e. Requests for adjustments in the Contract Time or the Contract Sum.
 - f. Requests for interpretation of Architect's actions on submittals.
 - g. Incomplete RFIs or inaccurately prepared RFIs.
 2. Architect's action may include a request for additional information, in which case Architect's time for response will date from time of receipt by Architect of additional information.
 3. Architect's action on RFIs that may result in a change to the Contract Time or the Contract Sum may be eligible for Contractor to submit Change Proposal according to Section 012600 "Contract Modification Procedures."
 - a. If Contractor believes the RFI response warrants change in the Contract Time or the Contract Sum, notify Architect in writing within 10 days of receipt of the RFI response.
- E. RFI Log: Prepare, maintain, and submit a tabular log of RFIs organized by the RFI number. Submit log weekly. Include the following:
 1. Project name.
 2. Name and address of Contractor.
 3. Name and address of Architect.
 4. RFI number including RFIs that were returned without action or withdrawn.
 5. RFI description.
 6. Date the RFI was submitted.
 7. Date Architect's response was received.
- F. On receipt of Architect's action, update the RFI log and immediately distribute the RFI response to affected parties. Review response and notify Architect within seven days if Contractor disagrees with response.

**Okaloosa County TDC – Emerald Coast Convention Center
Restroom Renovations and Meeting Room Counters**

1.8 DIGITAL PROJECT MANAGEMENT PROCEDURES

- A. Use of Architect's Digital Data Files: Digital data files of Architect's CAD drawings will be provided by Architect for Contractor's use during construction.
1. Digital data files may be used by Contractor in preparing coordination drawings, Shop Drawings, and Project record Drawings.
 2. Architect makes no representations as to the accuracy or completeness of digital data files as they relate to Contract Drawings.
 3. Contractor shall execute a data licensing agreement in the form of AIA Document C106 Digital Data Licensing Agreement.
 - a. Subcontractors, and other parties granted access by Contractor to Architect's digital data files shall execute a data licensing agreement in the form of AIA Document C106.
- B. PDF Document Preparation: Where PDFs are required to be submitted to Architect, prepare as follows:
1. Assemble complete submittal package into a single indexed file incorporating submittal requirements of a single Specification Section and transmittal form with links enabling navigation to each item.
 2. Name file with submittal number or other unique identifier, including revision identifier.
 3. Certifications: Where digitally submitted certificates and certifications are required, provide a digital signature with digital certificate on where indicated.

1.9 PROJECT MEETINGS

- A. General: Schedule and conduct meetings and conferences at Project site unless otherwise indicated.
- B. Preconstruction Conference: Architect will schedule and conduct a preconstruction conference before starting construction, at a time convenient to Owner and Architect, but no later than 15 days after execution of the Agreement.
1. Attendees: Authorized representatives of Owner, Architect, and their consultants; Contractor and its superintendent; major subcontractors; suppliers; and other concerned parties shall attend the conference. Participants at the conference shall be familiar with Project and authorized to conclude matters relating to the Work.
 2. Agenda: Discuss items of significance that could affect progress, including the following:
 - a. Responsibilities and personnel assignments.
 - b. Tentative construction schedule.
 - c. Phasing.
 - d. Critical work sequencing and long lead items.
 - e. Designation of key personnel and their duties.
 - f. Lines of communications.
 - g. Use of web-based Project software.

**Okaloosa County TDC – Emerald Coast Convention Center
Restroom Renovations and Meeting Room Counters**

- h. Procedures for processing field decisions and Change Orders.
 - i. Procedures for RFIs.
 - j. Procedures for testing and inspecting.
 - k. Procedures for processing Applications for Payment.
 - l. Distribution of the Contract Documents.
 - m. Submittal procedures.
 - n. Sustainable design requirements.
 - o. Preparation of Record Documents.
 - p. Use of the premises[and existing building].
 - q. Work restrictions.
 - r. Working hours.
 - s. Owner's occupancy requirements.
 - t. Responsibility for temporary facilities and controls.
 - u. Procedures for moisture and mold control.
 - v. Procedures for disruptions and shutdowns.
 - w. Construction waste management and recycling.
 - x. Parking availability.
 - y. Office, work, and storage areas.
 - z. Equipment deliveries and priorities.
 - aa. First aid.
 - bb. Security.
 - cc. Progress cleaning.
3. Minutes: Entity responsible for conducting meeting will record and distribute meeting minutes.
- C. Preinstallation Conferences: Conduct a preinstallation conference at Project site before each construction activity when required by other sections and when required for coordination with other construction.
- 1. Attendees: Installer and representatives of manufacturers and fabricators involved in or affected by the installation and its coordination or integration with other materials and installations that have preceded or will follow, shall attend the meeting. Advise Architect, and Owner of scheduled meeting dates.
 - 2. Agenda: Review progress of other construction activities and preparations for the particular activity under consideration, including requirements for the following:
 - a. Contract Documents.
 - b. Options.
 - c. Related RFIs.
 - d. Related Change Orders.
 - e. Purchases.
 - f. Deliveries.
 - g. Submittals.
 - h. Sustainable design requirements.
 - i. Review of mockups.
 - j. Possible conflicts.
 - k. Compatibility requirements.
 - l. Time schedules.

**Okaloosa County TDC – Emerald Coast Convention Center
Restroom Renovations and Meeting Room Counters**

- m. Weather limitations.
 - n. Manufacturer's written instructions.
 - o. Warranty requirements.
 - p. Compatibility of materials.
 - q. Acceptability of substrates.
 - r. Temporary facilities and controls.
 - s. Space and access limitations.
 - t. Regulations of authorities having jurisdiction.
 - u. Testing and inspecting requirements.
 - v. Installation procedures.
 - w. Coordination with other work.
 - x. Required performance results.
 - y. Protection of adjacent work.
 - z. Protection of construction and personnel.
- 3. Record significant conference discussions, agreements, and disagreements, including required corrective measures and actions.
 - 4. Reporting: Distribute minutes of the meeting to each party present and to other parties requiring information.
 - 5. Do not proceed with installation if the conference cannot be successfully concluded. Initiate whatever actions are necessary to resolve impediments to performance of the Work and reconvene the conference at earliest feasible date.
- D. Progress Meetings: Conduct progress meetings at weekly intervals.
- 1. Coordinate dates of meetings with preparation of payment requests.
 - 2. Attendees: In addition to representatives of Owner and Architect, each contractor, subcontractor, supplier, and other entity concerned with current progress or involved in planning, coordination, or performance of future activities shall be represented at these meetings. All participants at the meeting shall be familiar with Project and authorized to conclude matters relating to the Work.
 - 3. Agenda: Review and correct or approve minutes of previous progress meeting. Review other items of significance that could affect progress. Include topics for discussion as appropriate to status of Project.
 - a. Contractor's Construction Schedule: Review progress since the last meeting. Determine whether each activity is on time, ahead of schedule, or behind schedule, in relation to Contractor's construction schedule. Determine how construction behind schedule will be expedited; secure commitments from parties involved to do so. Discuss whether schedule revisions are required to ensure that current and subsequent activities will be completed within the Contract Time.
 - 1) Review schedule for next period.
 - b. Review present and future needs of each entity present, including the following:
 - 1) Interface requirements.
 - 2) Sequence of operations.
 - 3) Resolution of BIM component conflicts.

**Okaloosa County TDC – Emerald Coast Convention Center
Restroom Renovations and Meeting Room Counters**

- 4) Status of submittals.
 - 5) Status of sustainable design documentation.
 - 6) Deliveries.
 - 7) Off-site fabrication.
 - 8) Access.
 - 9) Site use.
 - 10) Temporary facilities and controls.
 - 11) Progress cleaning.
 - 12) Quality and work standards.
 - 13) Status of correction of deficient items.
 - 14) Field observations.
 - 15) Status of RFIs.
 - 16) Status of Proposal Requests.
 - 17) Pending changes.
 - 18) Status of Change Orders.
 - 19) Pending claims and disputes.
 - 20) Documentation of information for payment requests.
4. Minutes: Entity responsible for conducting the meeting will record and distribute the meeting minutes to each party present and to parties requiring information.
- a. Schedule Updating: Revise Contractor's construction schedule after each progress meeting where revisions to the schedule have been made or recognized. Issue revised schedule concurrently with the report of each meeting.

PART 2 - PRODUCTS (Not Used)

PART 3 - EXECUTION (Not Used)

END OF SECTION 013100

**Okaloosa County TDC – Emerald Coast Convention Center
Restroom Renovations and Meeting Room Counters**

SECTION 015000 - TEMPORARY FACILITIES AND CONTROLS

PART 1 - GENERAL

1.1 SUMMARY

- A. Section includes requirements for temporary utilities, support facilities, and security and protection facilities.
- B. Related Requirements:
 - 1. Section 011000 "Summary" for work restrictions and limitations on utility interruptions.

1.2 USE CHARGES

- A. General: Installation and removal of and use charges for temporary facilities shall be included in the Contract Sum unless otherwise indicated. Allow other entities engaged in the Project to use temporary services and facilities without cost, including, but not limited to, Owner's construction forces, Architect, occupants of Project, testing agencies, and authorities having jurisdiction.
- B. Water and Sewer Service from Existing System: Water from Owner's existing water system is available for use without metering and without payment of use charges. Provide connections and extensions of services as required for construction operations.
- C. Electric Power Service from Existing System: Electric power from Owner's existing system is available for use without metering and without payment of use charges. Provide connections and extensions of services as required for construction operations.

1.3 INFORMATIONAL SUBMITTALS

- A. Site Utilization Plan: Show temporary facilities, temporary utility lines and connections, staging areas, construction site entrances, vehicle circulation, and parking areas for construction personnel.
- B. Project Identification and Temporary Signs: Show fabrication and installation details, including plans, elevations, details, layouts, typestyles, graphic elements, and message content.
- C. Fire-Safety Program: Show compliance with requirements of NFPA 241 and authorities having jurisdiction. Indicate Contractor personnel responsible for management of fire-prevention program.
- D. Moisture-and Mold-Protection Plan: Describe procedures and controls for protecting materials and construction from water absorption and damage and mold.

**Okaloosa County TDC – Emerald Coast Convention Center
Restroom Renovations and Meeting Room Counters**

- E. Dust- and HVAC-Control Plan: Submit coordination drawing and narrative that indicates the dust- and HVAC-control measures proposed for use, proposed locations, and proposed time frame for their operation. Include the following:
1. Locations of dust-control partitions at each phase of work.
 2. HVAC system isolation schematic drawing.
 3. Location of proposed air-filtration system discharge.
 4. Waste-handling procedures.
 5. Other dust-control measures.

1.4 QUALITY ASSURANCE

- A. Electric Service: Comply with NECA, NEMA, and UL standards and regulations for temporary electric service. Install service to comply with NFPA 70.
- B. Tests and Inspections: Arrange for authorities having jurisdiction to test and inspect each temporary utility before use. Obtain required certifications and permits.
- C. Accessible Temporary Egress: Comply with applicable provisions in the United States Access Board's ADA-ABA Accessibility Guidelines and ICC/ANSI A117.1.

1.5 PROJECT CONDITIONS

- A. Temporary Use of Permanent Facilities: Engage Installer of each permanent service to assume responsibility for operation, maintenance, and protection of each permanent service during its use as a construction facility before Owner's acceptance, regardless of previously assigned responsibilities.

PART 2 - PRODUCTS

2.1 TEMPORARY FACILITIES

- A. Field Offices, General: Prefabricated or mobile units with serviceable finishes, temperature controls, and foundations adequate for normal loading.
- B. Common-Use Field Office: Of sufficient size to accommodate needs of Owner, Architect, and construction personnel office activities and to accommodate Project meetings specified in other Division 01 Sections. Keep office clean and orderly. Furnish and equip offices as follows:
1. Furniture required for Project-site documents including file cabinets, plan tables, plan racks, and bookcases.
 2. Drinking water and private toilet.
 3. Heating and cooling equipment necessary to maintain a uniform indoor temperature of 68 to 72 deg F (20 to 22 deg C).

**Okaloosa County TDC – Emerald Coast Convention Center
Restroom Renovations and Meeting Room Counters**

4. Lighting fixtures capable of maintaining average illumination of 20 fc (215 lx) at desk height.

2.2 EQUIPMENT

- A. Fire Extinguishers: Portable, UL rated; with class and extinguishing agent as required by locations and classes of fire exposures.
- B. HVAC Equipment: Unless Owner authorizes use of permanent HVAC system, provide vented, self-contained, liquid-propane-gas or fuel-oil heaters with individual space thermostatic control.
 1. Use of gasoline-burning space heaters, open-flame heaters, or salamander-type heating units is prohibited.
 2. Heating Units: Listed and labeled for type of fuel being consumed, by a qualified testing agency acceptable to authorities having jurisdiction, and marked for intended location and application.
 3. Permanent HVAC System: If Owner authorizes use of permanent HVAC system for temporary use during construction, provide filter with MERV of 8 at each return-air grille in system and remove at end of construction and clean HVAC system as required in Section 017700 "Closeout Procedures."]
- C. Air-Filtration Units: Primary and secondary HEPA-filter-equipped portable units with four-stage filtration. Provide single switch for emergency shutoff. Configure to run continuously.

PART 3 - EXECUTION

3.1 TEMPORARY FACILITIES, GENERAL

- A. Conservation: Coordinate construction and use of temporary facilities with consideration given to conservation of energy, water, and materials. Coordinate use of temporary utilities to minimize waste.
 1. Salvage materials and equipment involved in performance of, but not actually incorporated into, the Work. See other Sections for disposition of salvaged materials that are designated as Owner's property.

3.2 INSTALLATION, GENERAL

- A. Locate facilities where they will serve Project adequately and result in minimum interference with performance of the Work. Relocate and modify facilities as required by progress of the Work.
- B. Provide each facility ready for use when needed to avoid delay. Do not remove until facilities are no longer needed or are replaced by authorized use of completed permanent facilities.

**Okaloosa County TDC – Emerald Coast Convention Center
Restroom Renovations and Meeting Room Counters**

3.3 TEMPORARY UTILITY INSTALLATION

- A. General: Install temporary service or connect to existing service.
 - 1. Arrange with utility company, Owner, and existing users for time when service can be interrupted, if necessary, to make connections for temporary services.
- B. Sewers and Drainage: Provide temporary utilities to remove effluent lawfully.
 - 1. Connect temporary sewers to private system indicated as directed by authorities having jurisdiction.
- C. Water Service: Install water service and distribution piping in sizes and pressures adequate for construction.
- D. Sanitary Facilities: Provide temporary toilets, wash facilities, and drinking water for use of construction personnel. Comply with requirements of authorities having jurisdiction for type, number, location, operation, and maintenance of fixtures and facilities.
- E. Temporary Heating and Cooling: Provide temporary heating and cooling required by construction activities for curing or drying of completed installations or for protecting installed construction from adverse effects of low temperatures or high humidity. Select equipment that will not have a harmful effect on completed installations or elements being installed.
 - 1. Provide temporary dehumidification systems when required to reduce ambient and substrate moisture levels to level required to allow installation or application of finishes and their proper curing or drying.
- F. Isolation of Work Areas in Occupied Facilities: Prevent dust, fumes, and odors from entering occupied areas.
- G. Electric Power Service: Provide electric power service and distribution system of sufficient size, capacity, and power characteristics required for construction operations.
 - 1. Install electric power service overhead unless otherwise indicated.
- H. Lighting: Provide temporary lighting with local switching that provides adequate illumination for construction operations, observations, inspections, and traffic conditions.
 - 1. Install and operate temporary lighting that fulfills security and protection requirements without operating entire system.

3.4 SUPPORT FACILITIES INSTALLATION

- A. General: Comply with the following:

**Okaloosa County TDC – Emerald Coast Convention Center
Restroom Renovations and Meeting Room Counters**

1. Provide construction for temporary offices, shops, and sheds located within construction area or within **30 feet (9 m)** of building lines that is noncombustible according to ASTM E136. Comply with NFPA 241.
 2. Maintain support facilities until Architect schedules Substantial Completion inspection. Remove before Substantial Completion. Personnel remaining after Substantial Completion will be permitted to use permanent facilities, under conditions acceptable to Owner.
- B. Traffic Controls: Comply with requirements of authorities having jurisdiction.
1. Protect existing site improvements to remain including curbs, pavement, and utilities.
 2. Maintain access for fire-fighting equipment and access to fire hydrants.
- C. Parking: Use designated areas of Owner's existing parking areas for construction personnel.
- D. Project Signs: Provide Project signs as indicated. Unauthorized signs are not permitted.
1. Identification Signs: Provide Project identification signs as indicated on Drawings.
 2. Temporary Signs: Provide other signs as indicated and as required to inform public and individuals seeking entrance to Project.
 - a. Provide temporary, directional signs for construction personnel and visitors.
 3. Maintain and touch up signs so they are legible at all times.
- E. Waste Disposal Facilities: Provide waste-collection containers in sizes adequate to handle waste from construction operations. Comply with requirements of authorities having jurisdiction. Comply with progress cleaning requirements in Section 017300 "Execution."
- F. Lifts and Hoists: Provide facilities necessary for hoisting materials and personnel.
1. Truck cranes and similar devices used for hoisting materials are considered "tools and equipment" and not temporary facilities.
- G. Existing Stair Usage: Use of Owner's existing stairs will be permitted, provided stairs are cleaned and maintained in a condition acceptable to Owner. At Substantial Completion, restore stairs to condition existing before initial use.
1. Provide protective coverings, barriers, devices, signs, or other procedures to protect stairs and to maintain means of egress. If stairs become damaged, restore damaged areas so no evidence remains of correction work.
- 3.5 SECURITY AND PROTECTION FACILITIES INSTALLATION
- A. Protection of Existing Facilities: Protect existing vegetation, equipment, structures, utilities, and other improvements at Project site and on adjacent properties, except those indicated to be removed or altered. Repair damage to existing facilities.

**Okaloosa County TDC – Emerald Coast Convention Center
Restroom Renovations and Meeting Room Counters**

1. Where access to adjacent properties is required in order to affect protection of existing facilities, obtain written permission from adjacent property owner to access property for that purpose.
- B. Environmental Protection: Provide protection, operate temporary facilities, and conduct construction as required to comply with environmental regulations and that minimize possible air, waterway, and subsoil contamination or pollution or other undesirable effects.
- C. Pest Control: Engage pest-control service to recommend practices to minimize attraction and harboring of rodents, roaches, and other pests and to perform extermination and control procedures at regular intervals so Project will be free of pests and their residues at Substantial Completion. Perform control operations lawfully, using materials approved by authorities having jurisdiction.
- D. Site Enclosure Fence: Before construction operations begin, furnish and install site enclosure fence in a manner that will prevent people from easily entering site except by entrance gates.
 1. Extent of Fence: As required to enclose entire Project site or portion determined sufficient to accommodate construction operations.
 2. Maintain security by limiting number of keys and restricting distribution to authorized personnel. Furnish one set of keys to Owner.
- E. Security Enclosure and Lockup: Install temporary enclosure around partially completed areas of construction. Provide lockable entrances to prevent unauthorized entrance, vandalism, theft, and similar violations of security. Lock entrances at end of each workday.
- F. Barricades, Warning Signs, and Lights: Comply with requirements of authorities having jurisdiction for erecting structurally adequate barricades, including warning signs and lighting.
- G. Temporary Egress: Maintain temporary egress from existing occupied facilities as indicated and as required by authorities having jurisdiction.
- H. Temporary Enclosures: Provide temporary enclosures for protection of construction, in progress and completed, from exposure, foul weather, other construction operations, and similar activities. Provide temporary weathertight enclosure for building exterior.
 1. Where heating or cooling is needed and permanent enclosure is incomplete, insulate temporary enclosures.
- I. Temporary Partitions: Provide floor-to-ceiling dustproof partitions to limit dust and dirt migration and to separate areas occupied by Owner from fumes and noise.
 1. Construct dustproof partitions with gypsum wallboard with joints taped on occupied side, and fire-retardant-treated plywood on construction operations side.
 2. Where fire-resistance-rated temporary partitions are indicated or are required by authorities having jurisdiction, construct partitions according to the rated assemblies.
 3. Provide walk-off mats at each entrance through temporary partition.

**Okaloosa County TDC – Emerald Coast Convention Center
Restroom Renovations and Meeting Room Counters**

- J. Temporary Fire Protection: Install and maintain temporary fire-protection facilities of types needed to protect against reasonably predictable and controllable fire losses. Comply with NFPA 241; manage fire-prevention program.
1. Prohibit smoking in construction areas. Comply with additional limits on smoking specified in other Sections.
 2. Supervise welding operations, combustion-type temporary heating units, and similar sources of fire ignition according to requirements of authorities having jurisdiction.
 3. Develop and supervise an overall fire-prevention and -protection program for personnel at Project site. Review needs with local fire department and establish procedures to be followed. Instruct personnel in methods and procedures. Post warnings and information.
 4. Provide temporary standpipes and hoses for fire protection. Hang hoses with a warning sign stating that hoses are for fire-protection purposes only and are not to be removed. Match hose size with outlet size and equip with suitable nozzles.

3.6 MOISTURE AND MOLD CONTROL

- A. Contractor's Moisture-Protection Plan: Describe delivery, handling, storage, installation, and protection provisions for materials subject to water absorption or water damage.
1. Indicate procedures for discarding water-damaged materials, protocols for mitigating water intrusion into completed Work, and replacing water-damaged Work.
 2. Indicate sequencing of work that requires water, such as sprayed fire-resistive materials, plastering, and terrazzo grinding, and describe plans for dealing with water from these operations. Show procedures for verifying that wet construction has dried sufficiently to permit installation of finish materials.
 3. Indicate methods to be used to avoid trapping water in finished work.
- B. Exposed Construction Period: Before installation of weather barriers, when materials are subject to wetting and exposure and to airborne mold spores, protect as follows:
1. Protect porous materials from water damage.
 2. Protect stored and installed material from flowing or standing water.
 3. Keep porous and organic materials from coming into prolonged contact with concrete.
 4. Remove standing water from decks.
 5. Keep deck openings covered or dammed.
- C. Partially Enclosed Construction Period: After installation of weather barriers but before full enclosure and conditioning of building, when installed materials are still subject to infiltration of moisture and ambient mold spores, protect as follows:
1. Do not load or install drywall or other porous materials or components, or items with high organic content, into partially enclosed building.
 2. Keep interior spaces reasonably clean and protected from water damage.
 3. Periodically collect and remove waste containing cellulose or other organic matter.
 4. Discard or replace water-damaged material.
 5. Do not install material that is wet.
 6. Discard and replace stored or installed material that begins to grow mold.

**Okaloosa County TDC – Emerald Coast Convention Center
Restroom Renovations and Meeting Room Counters**

7. Perform work in a sequence that allows wet materials adequate time to dry before enclosing the material in gypsum board or other interior finishes.
- D. Controlled Construction Period: After completing and sealing of the building enclosure but prior to the full operation of permanent HVAC systems, maintain as follows:
1. Control moisture and humidity inside building by maintaining effective dry-in conditions.
 2. Use temporary or permanent HVAC system to control humidity within ranges specified for installed and stored materials.
 3. Comply with manufacturer's written instructions for temperature, relative humidity, and exposure to water limits.

3.7 OPERATION, TERMINATION, AND REMOVAL

- A. Supervision: Enforce strict discipline in use of temporary facilities. To minimize waste and abuse, limit availability of temporary facilities to essential and intended uses.
- B. Maintenance: Maintain facilities in good operating condition until removal.
1. Maintain operation of temporary enclosures, heating, cooling, humidity control, ventilation, and similar facilities on a 24-hour basis where required to achieve indicated results and to avoid possibility of damage.
- C. Temporary Facility Changeover: Do not change over from using temporary security and protection facilities to permanent facilities until Substantial Completion.
- D. Termination and Removal: Remove each temporary facility when need for its service has ended, when it has been replaced by authorized use of a permanent facility, or no later than Substantial Completion. Complete or, if necessary, restore permanent construction that may have been delayed because of interference with temporary facility. Repair damaged Work, clean exposed surfaces, and replace construction that cannot be satisfactorily repaired.
1. Materials and facilities that constitute temporary facilities are property of Contractor. Owner reserves right to take possession of Project identification signs.
 2. At Substantial Completion, repair, renovate, and clean permanent facilities used during construction period. Comply with final cleaning requirements specified in Section 017700 "Closeout Procedures."

END OF SECTION 015000

**Okaloosa County TDC – Emerald Coast Convention Center
Restroom Renovations and Meeting Room Counters**

SECTION 016000 - PRODUCT REQUIREMENTS

1.1 ACTION SUBMITTALS

- A. Comparable Product Requests: Architect will notify Contractor of approval or rejection within 15 days of receipt of request, or seven days of receipt of additional information.

1.2 PRODUCT DELIVERY, STORAGE, AND HANDLING

- A. Use means and methods that will prevent damage, deterioration, and loss, including theft.
- B. Store products to allow for inspection and measurement or counting of units.
- C. Provide for storage of materials and equipment by Owner.

1.3 PRODUCT WARRANTIES

- A. Manufacturer's disclaimers and limitations on product warranties do not relieve Contractor of obligations under requirements of the Contract Documents.
- B. Special Warranties: Prepare a written document that contains appropriate terms and identification, ready for execution.

1.4 PRODUCT SELECTION PROCEDURES

- A. Product Selection Procedures:
 - 1. Product: Product named that complies with requirements.
 - 2. Manufacturer/Source: Product by manufacturer or from source named that complies with requirements.
 - 3. Products: One of the products listed that complies with requirements. Comparable products will be considered unless otherwise indicated.
 - 4. Manufacturers: Product by one of the manufacturers listed that complies with requirements. Comparable products will be considered unless otherwise indicated.
 - 5. Basis-of-Design Product: Either the specified product or a comparable product by one of the other named manufacturers.
 - 6. Visual Matching Specification: Product that matches Architect's sample. Architect's decision will be final.
 - 7. Visual Selection Specification: Product (and manufacturer) that complies with other specified requirements. Architect will select color, gloss, pattern, density, or texture from manufacturer's product line that includes both standard and premium items.

**Okaloosa County TDC – Emerald Coast Convention Center
Restroom Renovations and Meeting Room Counters**

1.5 COMPARABLE PRODUCTS

A. Conditions for Consideration:

1. Product does not require revisions to the Contract Documents, is consistent with the Contract Documents and will produce the indicated results, and is compatible with other portions of the Work.
2. Comparison of proposed product with those named in the Specifications.
3. Product provides specified warranty.
4. Similar installations, if requested.
5. Samples, if requested.

END OF SECTION 016000

**Okaloosa County TDC – Emerald Coast Convention Center
Restroom Renovations and Meeting Room Counters**

SECTION 017300 - EXECUTION

PART 1 - GENERAL

1.1 SUMMARY

- A. Section includes general administrative and procedural requirements governing execution of the Work including, but not limited to, the following:
 - 1. Construction layout.
 - 2. Field engineering and surveying.
 - 3. Installation of the Work.
 - 4. Cutting and patching.
 - 5. Progress cleaning.
 - 6. Starting and adjusting.
 - 7. Protection of installed construction.

- B. Related Requirements:
 - 1. Section 011000 "Summary" for limits on use of Project site.

1.2 INFORMATIONAL SUBMITTALS

- A. Landfill Receipts: Submit copy of receipts issued by a landfill facility, licensed to accept hazardous materials, for hazardous waste disposal.

1.3 QUALITY ASSURANCE

- A. Cutting and Patching: Comply with requirements for and limitations on cutting and patching of construction elements.
 - 1. Structural Elements: When cutting and patching structural elements, notify Architect of locations and details of cutting and await directions from Architect before proceeding. Shore, brace, and support structural elements during cutting and patching. Do not cut and patch structural elements in a manner that could change their load-carrying capacity or increase deflection.
 - 2. Operational Elements: Do not cut and patch operating elements and related components in a manner that results in reducing their capacity to perform as intended or that results in increased maintenance or decreased operational life or safety.
 - 3. Other Construction Elements: Do not cut and patch other construction elements or components in a manner that could change their load-carrying capacity, that results in reducing their capacity to perform as intended, or that results in increased maintenance or decreased operational life or safety.

**Okaloosa County TDC – Emerald Coast Convention Center
Restroom Renovations and Meeting Room Counters**

4. Visual Elements: Do not cut and patch construction in a manner that results in visual evidence of cutting and patching. Do not cut and patch exposed construction in a manner that would, in Architect's opinion, reduce the building's aesthetic qualities. Remove and replace construction that has been cut and patched in a visually unsatisfactory manner.
- B. Manufacturer's Installation Instructions: Obtain and maintain on-site manufacturer's written recommendations and instructions for installation of products and equipment.

PART 2 - PRODUCTS

2.1 MATERIALS

- A. In-Place Materials: Use materials for patching identical to in-place materials. For exposed surfaces, use materials that visually match in-place adjacent surfaces to the fullest extent possible.
1. If identical materials are unavailable or cannot be used, use materials that, when installed, will provide a match acceptable to Architect for the visual and functional performance of in-place materials.

PART 3 - EXECUTION

3.1 EXAMINATION

- A. Existing Conditions: The existence and location of utilities and construction indicated as existing are not guaranteed. Before beginning work, investigate and verify the existence and location of utilities, mechanical and electrical systems, and other construction affecting the Work.
1. Before construction, verify the location and points of connection of sanitary sewer, storm sewer, and water-service piping; underground electrical services; and other utilities.
 2. Furnish location data for work related to Project that must be performed by public utilities serving Project site.
- B. Examination and Acceptance of Conditions: Before proceeding with each component of the Work, examine substrates, areas, and conditions, with Installer or Applicator present where indicated, for compliance with requirements for installation tolerances and other conditions affecting performance. Record observations.
1. Examine roughing-in for mechanical and electrical systems to verify actual locations of connections before equipment and fixture installation.
 2. Examine walls, floors, and roofs for suitable conditions where products and systems are to be installed.
 3. Verify compatibility with and suitability of substrates, including compatibility with existing finishes or primers.

**Okaloosa County TDC – Emerald Coast Convention Center
Restroom Renovations and Meeting Room Counters**

- C. Proceed with installation only after unsatisfactory conditions have been corrected. Proceeding with the Work indicates acceptance of surfaces and conditions.

3.2 PREPARATION

- A. Existing Utility Information: Furnish information to Owner that is necessary to adjust, move, or relocate existing utility structures, utility poles, lines, services, or other utility appurtenances located in or affected by construction. Coordinate with authorities having jurisdiction.
- B. Field Measurements: Take field measurements as required to fit the Work properly. Recheck measurements before installing each product. Where portions of the Work are indicated to fit to other construction, verify dimensions of other construction by field measurements before fabrication. Coordinate fabrication schedule with construction progress to avoid delaying the Work.
- C. Space Requirements: Verify space requirements and dimensions of items shown diagrammatically on Drawings.
- D. Review of Contract Documents and Field Conditions: Immediately on discovery of the need for clarification of the Contract Documents caused by differing field conditions outside the control of Contractor, submit a request for information to Architect.

3.3 CONSTRUCTION LAYOUT

- A. Verification: Before proceeding to lay out the Work, verify layout information shown on Drawings. If discrepancies are discovered, notify Architect promptly.
- B. General: Lay out the Work using accepted surveying practices.
 - 1. Establish benchmarks and control points to set lines and levels of construction and elsewhere as needed to locate each element of Project.
 - 2. Establish limits on use of Project site.
 - 3. Establish dimensions within tolerances indicated. Do not scale Drawings to obtain required dimensions.
 - 4. Inform installers of lines and levels to which they must comply.
 - 5. Check the location, level and plumb, of every major element as the Work progresses.
 - 6. Notify Architect when deviations from required lines and levels exceed allowable tolerances.

3.4 INSTALLATION

- A. General: Locate the Work and components of the Work accurately, in correct alignment and elevation, as indicated.
 - 1. Make vertical work plumb and make horizontal work level.

**Okaloosa County TDC – Emerald Coast Convention Center
Restroom Renovations and Meeting Room Counters**

2. Where space is limited, install components to maximize space available for maintenance and ease of removal for replacement.
 3. Conceal pipes, ducts, and wiring in finished areas unless otherwise indicated.
- B. Comply with manufacturer's written instructions and recommendations for installing products in applications indicated.
- C. Install products at the time and under conditions that will ensure the best possible results. Maintain conditions required for product performance until Substantial Completion.
- D. Conduct construction operations so no part of the Work is subjected to damaging operations or loading in excess of that expected during normal conditions of occupancy.
- E. Sequence the Work and allow adequate clearances to accommodate movement of construction items on site and placement in permanent locations.
- F. Tools and Equipment: Where possible, select tools or equipment that minimize production of excessive noise levels.
- G. Templates: Obtain and distribute to the parties involved templates for work specified to be factory prepared and field installed. Check Shop Drawings of other portions of the Work to confirm that adequate provisions are made for locating and installing products to comply with indicated requirements.
- H. Attachment: Provide blocking and attachment plates and anchors and fasteners of adequate size and number to securely anchor each component in place, accurately located and aligned with other portions of the Work. Where size and type of attachments are not indicated, verify size and type required for load conditions.
1. Mounting Heights: Where mounting heights are not indicated, mount components at heights directed by Architect.
 2. Allow for building movement, including thermal expansion and contraction.
 3. Coordinate installation of anchorages. Furnish setting drawings, templates, and directions for installing anchorages, including sleeves, concrete inserts, anchor bolts, and items with integral anchors, that are to be embedded in concrete or masonry. Deliver such items to Project site in time for installation.
- I. Joints: Make joints of uniform width. Where joint locations in exposed work are not indicated, arrange joints for the best visual effect. Fit exposed connections together to form hairline joints.
- J. Remove and replace damaged, defective, or non-conforming Work.

3.5 CUTTING AND PATCHING

- A. Cutting and Patching, General: Employ skilled workers to perform cutting and patching. Proceed with cutting and patching at the earliest feasible time, and complete without delay.

**Okaloosa County TDC – Emerald Coast Convention Center
Restroom Renovations and Meeting Room Counters**

1. Cut in-place construction to provide for installation of other components or performance of other construction, and subsequently patch as required to restore surfaces to their original condition.
- B. Existing Warranties: Remove, replace, patch, and repair materials and surfaces cut or damaged during installation or cutting and patching operations, by methods and with materials so as not to void existing warranties.
- C. Temporary Support: Provide temporary support of work to be cut.
- D. Protection: Protect in-place construction during cutting and patching to prevent damage. Provide protection from adverse weather conditions for portions of Project that might be exposed during cutting and patching operations.
- E. Adjacent Occupied Areas: Where interference with use of adjoining areas or interruption of free passage to adjoining areas is unavoidable, coordinate cutting and patching according to requirements in Section 011000 "Summary."
- F. Existing Utility Services and Mechanical/Electrical Systems: Where existing services/systems are required to be removed, relocated, or abandoned, bypass such services/systems before cutting to minimize or prevent interruption to occupied areas.
- G. Cutting: Cut in-place construction by sawing, drilling, breaking, chipping, grinding, and similar operations, including excavation, using methods least likely to damage elements retained or adjoining construction. If possible, review proposed procedures with original Installer; comply with original Installer's written recommendations.
 1. In general, use hand or small power tools designed for sawing and grinding, not hammering and chopping. Cut holes and slots neatly to minimum size required, and with minimum disturbance of adjacent surfaces. Temporarily cover openings when not in use.
 2. Finished Surfaces: Cut or drill from the exposed or finished side into concealed surfaces.
 3. Concrete and Masonry: Cut using a cutting machine, such as an abrasive saw or a diamond-core drill.
 4. Excavating and Backfilling: Comply with requirements in applicable Sections where required by cutting and patching operations.
 5. Mechanical and Electrical Services: Cut off pipe or conduit in walls or partitions to be removed. Cap, valve, or plug and seal remaining portion of pipe or conduit to prevent entrance of moisture or other foreign matter after cutting.
 6. Proceed with patching after construction operations requiring cutting are complete.
- H. Patching: Patch construction by filling, repairing, refinishing, closing up, and similar operations following performance of other work. Patch with durable seams that are as invisible as practicable. Provide materials and comply with installation requirements specified in other Sections, where applicable.
 1. Inspection: Where feasible, test and inspect patched areas after completion to demonstrate physical integrity of installation.

**Okaloosa County TDC – Emerald Coast Convention Center
Restroom Renovations and Meeting Room Counters**

2. Exposed Finishes: Restore exposed finishes of patched areas and extend finish restoration into retained adjoining construction in a manner that will minimize evidence of patching and refinishing.
 3. Floors and Walls: Where walls or partitions that are removed extend one finished area into another, patch and repair floor and wall surfaces in the new space. Provide an even surface of uniform finish, color, texture, and appearance. Remove in-place floor and wall coverings and replace with new materials, if necessary, to achieve uniform color and appearance.
 4. Ceilings: Patch, repair, or rehang in-place ceilings as necessary to provide an even-plane surface of uniform appearance.
 5. Exterior Building Enclosure: Patch components in a manner that restores enclosure to a weathertight condition and ensures thermal and moisture integrity of building enclosure.
- I. Cleaning: Clean areas and spaces where cutting and patching are performed. Remove paint, mortar, oils, putty, and similar materials from adjacent finished surfaces.

3.6 PROGRESS CLEANING

- A. General: Clean Project site and work areas daily, including common areas. Enforce requirements strictly. Dispose of materials lawfully.
1. Comply with requirements in NFPA 241 for removal of combustible waste materials and debris.
 2. Do not hold waste materials more than seven days during normal weather or three days if the temperature is expected to rise above 80 deg F (27 deg C).
 3. Containerize hazardous and unsanitary waste materials separately from other waste. Mark containers appropriately and dispose of legally, according to regulations.
 - a. Use containers intended for holding waste materials of type to be stored.
 4. Coordinate progress cleaning for joint-use areas where Contractor and other contractors are working concurrently.
- B. Site: Maintain Project site free of waste materials and debris.
- C. Work Areas: Clean areas where work is in progress to the level of cleanliness necessary for proper execution of the Work.
1. Remove liquid spills promptly.
 2. Where dust would impair proper execution of the Work, broom-clean or vacuum the entire work area, as appropriate.
- D. Installed Work: Keep installed work clean. Clean installed surfaces according to written instructions of manufacturer or fabricator of product installed, using only cleaning materials specifically recommended. If specific cleaning materials are not recommended, use cleaning materials that are not hazardous to health or property and that will not damage exposed surfaces.
- E. Concealed Spaces: Remove debris from concealed spaces before enclosing the space.

**Okaloosa County TDC – Emerald Coast Convention Center
Restroom Renovations and Meeting Room Counters**

- F. Exposed Surfaces in Finished Areas: Clean exposed surfaces and protect as necessary to ensure freedom from damage and deterioration at time of Substantial Completion.
- G. Waste Disposal: Do not bury or burn waste materials on-site. Do not wash waste materials down sewers or into waterways.
- H. During handling and installation, clean and protect construction in progress and adjoining materials already in place. Apply protective covering where required to ensure protection from damage or deterioration at Substantial Completion.
- I. Clean and provide maintenance on completed construction as frequently as necessary through the remainder of the construction period. Adjust and lubricate operable components to ensure operability without damaging effects.
- J. Limiting Exposures: Supervise construction operations to ensure that no part of the construction, completed or in progress, is subject to harmful, dangerous, damaging, or otherwise deleterious exposure during the construction period.

3.7 PROTECTION OF INSTALLED CONSTRUCTION

- A. Provide final protection and maintain conditions that ensure installed Work is without damage or deterioration at time of Substantial Completion.
- B. Protection of Existing Items: Provide protection and ensure that existing items to remain undisturbed by construction are maintained in condition that existed at commencement of the Work.
- C. Comply with manufacturer's written instructions for temperature and relative humidity.

END OF SECTION 017300

**Okaloosa County TDC – Emerald Coast Convention Center
Restroom Renovations and Meeting Room Counters**

Page left blank

**Okaloosa County TDC – Emerald Coast Convention Center
Restroom Renovations and Meeting Room Counters**

SECTION 024119 - SELECTIVE DEMOLITION

PART 1 - GENERAL

1.1 SUMMARY

A. Section Includes:

1. Demolition and removal of selected portions of building or structure.
2. Demolition and removal of selected system elements.
3. Salvage of existing items to be reused or recycled.

1.2 MATERIALS OWNERSHIP

- A. Unless otherwise indicated, demolition waste becomes property of Contractor.

1.3 PREINSTALLATION MEETINGS

- A. Predemolition Conference: Conduct conference at Project site.

1.4 INFORMATIONAL SUBMITTALS

- A. Survey: Submit survey of conditions of the building and systems to be replaced.
- B. Proposed Protection Measures: Submit report, including Drawings, that indicates the measures proposed for protecting individuals and property, for environmental protection, for dust control and for noise control. Indicate proposed locations and construction of barriers.
- C. Schedule of selective demolition activities with starting and ending dates for each activity.
- D. Predemolition photographs or video.

1.5 CLOSEOUT SUBMITTALS

- A. Inventory of items that have been removed and salvaged.

1.6 FIELD CONDITIONS

- A. Owner will occupy portions of building immediately adjacent to selective demolition area. Conduct selective demolition so Owner's operations will not be disrupted.

**Okaloosa County TDC – Emerald Coast Convention Center
Restroom Renovations and Meeting Room Counters**

- B. Conditions existing at time of inspection for bidding purpose will be maintained by Owner as far as practical.
- C. Notify Architect of discrepancies between existing conditions and Drawings before proceeding with selective demolition.
- D. Hazardous Materials: It is not expected that hazardous materials will be encountered in the Work.
 - 1. If suspected hazardous materials are encountered, do not disturb; immediately notify Architect and Owner. Hazardous materials will be removed by Owner under a separate contract.
- E. Storage or sale of removed items or materials on-site is not permitted.
- F. Utility Service: Maintain existing utilities indicated to remain in service and protect them against damage during selective demolition operations.
 - 1. Maintain fire-protection facilities in service during selective demolition operations.
- G. Arrange selective demolition schedule so as not to interfere with Owner's operations.

1.7 WARRANTY

- A. Existing Warranties: Remove, replace, patch, and repair materials and surfaces cut or damaged during selective demolition, by methods and with materials and using approved contractors so as not to void existing warranties.

PART 2 - PRODUCTS

2.1 PERFORMANCE REQUIREMENTS

- A. Regulatory Requirements: Comply with governing EPA notification regulations before beginning selective demolition. Comply with hauling and disposal regulations of authorities having jurisdiction.
- B. Standards: Comply with ASSE A10.6 and NFPA 241.

PART 3 - EXECUTION

3.1 EXAMINATION

- A. Verify that utilities have been disconnected and capped before starting selective demolition operations.

**Okaloosa County TDC – Emerald Coast Convention Center
Restroom Renovations and Meeting Room Counters**

- B. Perform a survey of condition of building to determine whether removing any element might result in structural deficiency or unplanned collapse of any portion of structure or adjacent structures during selective building demolition operations.
- C. Inventory and record the condition of items to be removed and salvaged.

3.2 UTILITY SERVICES AND MECHANICAL/ELECTRICAL SYSTEMS

- A. Existing Services/Systems to Remain: Maintain services/systems indicated to remain and protect them against damage.
- B. Existing Services/Systems to Be Removed, Relocated, or Abandoned: Locate, identify, disconnect, and seal or cap off utility services and mechanical/electrical systems serving areas to be selectively demolished.
 - 1. Owner will arrange to shut off indicated services/systems when requested by Contractor.
 - 2. Arrange to shut off utilities with utility companies.
 - 3. If services/systems are required to be removed, relocated, or abandoned, provide temporary services/systems that bypass area of selective demolition and that maintain continuity of services/systems to other parts of building.
 - 4. Disconnect, demolish, and remove fire-suppression systems, plumbing, and equipment, and components indicated on Drawings to be removed.
 - a. Piping to Be Removed: Remove portion of piping indicated to be removed and cap or plug remaining piping with same or compatible piping material.
 - b. Piping to Be Abandoned in Place: Drain piping and cap or plug piping with same or compatible piping material and leave in place.
 - c. Equipment to Be Removed: Disconnect and cap services and remove equipment.
 - d. Equipment to Be Removed and Reinstalled: Disconnect and cap services and remove, clean, and store equipment; when appropriate, reinstall, reconnect, and make equipment operational.
 - e. Equipment to Be Removed and Salvaged: Disconnect and cap services and remove equipment and deliver to Owner.

3.3 PROTECTION

- A. Temporary Protection: Provide temporary barricades and other protection required to prevent injury to people and damage to adjacent buildings and facilities to remain.
- B. Temporary Shoring: Design, provide, and maintain shoring, bracing, and structural supports as required to preserve stability and prevent movement, settlement, or collapse of construction and finishes to remain, and to prevent unexpected or uncontrolled movement or collapse of construction being demolished.
- C. Remove temporary barricades and protections where hazards no longer exist.

**Okaloosa County TDC – Emerald Coast Convention Center
Restroom Renovations and Meeting Room Counters**

3.4 SELECTIVE DEMOLITION

- A. General: Demolish and remove existing construction only to the extent required by new construction and as indicated. Use methods required to complete the Work within limitations of governing regulations and as follows:
1. Neatly cut openings and holes plumb, square, and true to dimensions required. Use cutting methods least likely to damage construction to remain or adjoining construction. Use hand tools or small power tools designed for sawing or grinding, not hammering and chopping. Temporarily cover openings to remain.
 2. Cut or drill from the exposed or finished side into concealed surfaces to avoid marring existing finished surfaces.
 3. Do not use cutting torches until work area is cleared of flammable materials. At concealed spaces, such as duct and pipe interiors, verify condition and contents of hidden space before starting flame-cutting operations. Maintain portable fire-suppression devices during flame-cutting operations.
 4. Maintain fire watch during and for at least 24 hours after flame-cutting operations.
 5. Locate selective demolition equipment and remove debris and materials so as not to impose excessive loads on supporting walls, floors, or framing.
 6. Dispose of demolished items and materials promptly.
- B. Site Access and Temporary Controls: Conduct selective demolition and debris-removal operations to ensure minimum interference with roads, streets, walks, walkways, and other adjacent occupied and used facilities.
- C. Removed and Salvaged Items:
1. Clean salvaged items.
 2. Pack or crate items after cleaning. Identify contents of containers.
 3. Store items in a secure area until delivery to Owner.
 4. Transport items to Owner's storage area designated by Owner.
 5. Protect items from damage during transport and storage.
- D. Removed and Reinstalled Items:
1. Clean and repair items to functional condition adequate for intended reuse.
 2. Pack or crate items after cleaning and repairing. Identify contents of containers.
 3. Protect items from damage during transport and storage.
 4. Reinstall items in locations indicated. Comply with installation requirements for new materials and equipment. Provide connections, supports, and miscellaneous materials necessary to make item functional for use indicated.
- E. Existing Items to Remain: Protect construction indicated to remain against damage and soiling during selective demolition. When permitted by Architect, items may be removed to a suitable, protected storage location during selective demolition and cleaned and reinstalled in their original locations after selective demolition operations are complete.

**Okaloosa County TDC – Emerald Coast Convention Center
Restroom Renovations and Meeting Room Counters**

3.5 CLEANING

- A. Remove demolition waste materials from Project site and dispose of them in an EPA-approved construction and demolition waste landfill acceptable to authorities having jurisdiction.
 - 1. Do not allow demolished materials to accumulate on-site.
 - 2. Remove and transport debris in a manner that will prevent spillage on adjacent surfaces and areas.
- B. Burning: Do not burn demolished materials.
- C. Clean adjacent structures and improvements of dust, dirt, and debris caused by selective demolition operations. Return adjacent areas to condition existing before selective demolition operations began.

END OF SECTION 024119

**Okaloosa County TDC – Emerald Coast Convention Center
Restroom Renovations and Meeting Room Counters**

Page Left Blank

**Okaloosa County TDC – Emerald Coast Convention Center
Restroom Renovations and Meeting Room Counters**

SECTION 072100 - THERMAL INSULATION

PART 1 - GENERAL

1.1 SUMMARY

- A. Section Includes:
 - 1. Glass-fiber blanket.

1.2 ACTION SUBMITTALS

- A. Product Data: For each type of product.
- B. Low-emitting product certification.

1.3 INFORMATIONAL SUBMITTALS

- A. Product test reports.
- B. Research reports.

PART 2 - PRODUCTS

2.1 GLASS-FIBER BLANKET

- A. Sustainability Requirements: Provide glass-fiber blanket insulation as follows:
 - 1. Free of Formaldehyde: Insulation manufactured with 100 percent acrylic binders and no formaldehyde.
 - 2. Low Emitting: Insulation tested according to ASTM D 5116 and shown to emit less than 0.05-ppm formaldehyde.
 - 3. Low Emitting: Complies with the testing and product requirements of the California Department of Public Health's (formerly, the California Department of Health Services') "Standard Method for the Testing and Evaluation of Volatile Organic Chemical Emissions from Indoor Sources Using Environmental Chambers."
- B. Glass-Fiber Blanket, Unfaced: ASTM C 665, Type I; with maximum flame-spread and smoke-developed indexes of 25 and 50, respectively, per ASTM E 84; passing ASTM E 136 for combustion characteristics.

2.2 ACCESSORIES

- A. Insulation for Miscellaneous Voids:

**Okaloosa County TDC – Emerald Coast Convention Center
Restroom Renovations and Meeting Room Counters**

- B. Insulation Anchors, Spindles, and Standoffs: To prevent sagging and movement as recommended by manufacturer.

PART 3 - EXECUTION

3.1 INSTALLATION, GENERAL

- A. Comply with insulation manufacturer's written instructions applicable to products and applications.
- B. Install insulation that is undamaged, dry, and unsoiled and that has not been left exposed to ice, rain, or snow at any time.
- C. Extend insulation to envelop entire area to be insulated. Fit tightly around obstructions and fill voids with insulation. Remove projections that interfere with placement.
- D. Provide sizes to fit applications and selected from manufacturer's standard thicknesses, widths, and lengths. Apply single layer of insulation units unless multiple layers are otherwise shown or required to make up total thickness or to achieve R-value.
- E. Install sound batting insulation as shown on drawings

3.2 INSTALLATION OF INSULATION IN FRAMED CONSTRUCTION

- A. Blanket Insulation: Install in cavities formed by framing members according to the following requirements:
 - 1. Use insulation widths and lengths that fill the cavities formed by framing members. If more than one length is required to fill the cavities, provide lengths that will produce a snug fit between ends.
 - 2. Place insulation in cavities formed by framing members to produce a friction fit between edges of insulation and adjoining framing members.
 - 3. Maintain 3-inch (76-mm) clearance of insulation around recessed lighting fixtures not rated for or protected from contact with insulation.
 - 4. For metal-framed wall cavities where cavity heights exceed 96 inches (2438 mm), support unfaced blankets mechanically.
- B. Miscellaneous Voids: Install insulation in miscellaneous voids and cavity spaces where required to prevent gaps in insulation using the following materials:
 - 1. Glass-Fiber Insulation: Compact to approximately 40 percent of normal maximum volume equaling a density of approximately 2.5 lb/cu. ft. (40 kg/cu. m).

END OF SECTION 072100

**Okaloosa County TDC – Emerald Coast Convention Center
Restroom Renovations and Meeting Room Counters**

SECTION 072119 - FOAMED-IN-PLACE INSULATION

PART 1 - GENERAL

1.1 RELATED DOCUMENTS

- A. Drawings and general provisions of the Contract, including General and Supplementary Conditions and Division 01 Specification Sections, apply to this Section.

1.2 SUMMARY

- A. Section Includes:
 - 1. Closed-cell spray polyurethane foam.
 - 2. Intumescent Coating

1.3 ACTION SUBMITTALS

- A. Product Data: For each type of product.

1.4 INFORMATIONAL SUBMITTALS

- A. Qualification Data: For Installer.
- B. Product Test Reports: For each product, for tests performed by a qualified testing agency.
- C. Evaluation Reports: For each product, from ICC-ES.

1.5 QUALITY ASSURANCE

- A. Installer Qualifications: An authorized representative who is trained and approved by manufacturer.

PART 2 - PRODUCTS

2.1 CLOSED-CELL SPRAY POLYURETHANE FOAM

- A. Closed-Cell Spray Polyurethane Foam: ASTM C1029, Type II, minimum density of 1.5 lb/cu. ft. (24 kg/cu. m) and minimum aged R-value at 1-inch (25.4-mm) thickness of 6.2 deg F x h x sq. ft./Btu at 75 deg F (43 K x sq. m/W at 24 deg C).

**Okaloosa County TDC – Emerald Coast Convention Center
Restroom Renovations and Meeting Room Counters**

1. Surface-Burning Characteristics: Comply with ASTM E84; testing by a qualified testing agency. Identify products with appropriate markings of applicable testing agency.
 - a. Flame-Spread Index: 25 or less.
 - b. Smoke-Developed Index: 450 or less.
2. Fire Propagation Characteristics: Passes NFPA 285 testing as part of an approved assembly.

2.2 INTUMESCENT COATING

- A. Intumescent coating approved as an Alternative Barrier System, applied over SPF and tested to the criteria of NFPA 286, UL 1715 or ISO-CAN/ULC 9705 for duration of 15-20 minutes by an accredited fire testing facility.
- B. Coating must be approved for installation in high humidity and unconditioned exterior spaces.
- C. Color as selected by architect from full range of manufacture's colors available.

2.3 MISCELLANEOUS MATERIALS

- A. Primer: Material recommended by insulation manufacturer where required for adhesion of insulation to substrates.

PART 3 - EXECUTION

3.1 PREPARATION

- A. Verify that substrates are clean, dry, and free of substances that are harmful to insulation.
- B. Priming: Prime substrates where recommended by insulation manufacturer. Apply primer to comply with insulation manufacturer's written instructions. Confine primers to areas to be insulated; do not allow spillage or migration onto adjoining surfaces.
- C. Mask or seal piping, hangers or other penetrations as required and recommended by insulation manufacturer.

3.2 INSTALLATION

- A. Comply with insulation manufacturer's written instructions applicable to products and applications.
- B. Spray insulation to envelop entire area to be insulated and fill voids. Apply intumescent coating over all exposed SPF surfaces in accordance with manufacturer's written instructions.

**Okaloosa County TDC – Emerald Coast Convention Center
Restroom Renovations and Meeting Room Counters**

- C. Apply in multiple passes to not exceed maximum thicknesses recommended by manufacturer. Do not spray into rising foam.
- D. Miscellaneous Voids: Apply according to manufacturer's written instructions.

3.3 PROTECTION

- A. Protect installed insulation from damage due to harmful weather exposures, physical abuse, and other causes.

PART 4 – SCHEDULE

- A. Two (2) inch cured thickness foamed in place insulation with intumescent coating under Restrooms #1, #2, #3, #4, #5 & #6 slabs as designated on Sheet A101.

END OF SECTION 072119

**Okaloosa County TDC – Emerald Coast Convention Center
Restroom Renovations and Meeting Room Counters**

Page left blank

**Okaloosa County TDC – Emerald Coast Convention Center
Restroom Renovations and Meeting Room Counters**

SECTION 079200 - JOINT SEALANTS

PART 1 - GENERAL

1.1 SUMMARY

A. Section Includes:

1. Silicone joint sealants.
2. Nonstaining silicone joint sealants.
3. Mildew-resistant joint sealants.

1.2 PREINSTALLATION MEETINGS

- A. Preinstallation Conference: Conduct conference at [Project site] <Insert location>.

1.3 ACTION SUBMITTALS

- A. Product Data: For each joint-sealant product.
- B. Samples: For each kind and color of joint sealant required.
- C. Joint-Sealant Schedule: Include the following information:
1. Joint-sealant application, joint location, and designation.
 2. Joint-sealant manufacturer and product name.
 3. Joint-sealant formulation.
 4. Joint-sealant color.

1.4 INFORMATIONAL SUBMITTALS

- A. Product test reports.
- B. Preconstruction laboratory test reports.
- C. Preconstruction field-adhesion-test reports.
- D. Field-adhesion-test reports.
- E. Sample warranties.

**Okaloosa County TDC – Emerald Coast Convention Center
Restroom Renovations and Meeting Room Counters**

1.5 QUALITY ASSURANCE

- A. Testing Agency Qualifications: Qualified according to ASTM C1021 to conduct the testing indicated.

1.6 PRECONSTRUCTION TESTING

- A. Preconstruction Laboratory Testing: Submit to joint-sealant manufacturers, for testing indicated below, samples of materials that will contact or affect joint sealants.
 - 1. Adhesion Testing: Use ASTM C794 to determine whether priming and other specific joint preparation techniques are required to obtain rapid, optimum adhesion of joint sealants to joint substrates.
 - 2. Compatibility Testing: Use ASTM C1087 to determine sealant compatibility when in contact with glazing and gasket materials.
- B. Preconstruction Field-Adhesion Testing: Before installing sealants, field test their adhesion to Project joint substrates. Test joint sealants according to Method A, Field-Applied Sealant Joint Hand Pull Tab, in Appendix X1.1 in ASTM C1193 or Method A, Tail Procedure, in ASTM C1521.

1.7 WARRANTY

- A. Special Installer's Warranty: Installer agrees to repair or replace joint sealants that do not comply with performance and other requirements specified in this Section within specified warranty period.
 - 1. Warranty Period: Two years from date of Substantial Completion.
- B. Special Manufacturer's Warranty: Manufacturer agrees to furnish joint sealants to repair or replace those joint sealants that do not comply with performance and other requirements specified in this Section within specified warranty period.
 - 1. Warranty Period: Five years from date of Substantial Completion.

PART 2 - PRODUCTS

2.1 JOINT SEALANTS, GENERAL

- A. Colors of Exposed Joint Sealants: As selected by Architect from manufacturer's full range.

**Okaloosa County TDC – Emerald Coast Convention Center
Restroom Renovations and Meeting Room Counters**

2.2 SILICONE JOINT SEALANTS

- A. Silicone, S, NS, 100/50, NT: Single-component, nonsag, plus 100 percent and minus 50 percent movement capability, nontraffic-use, neutral-curing silicone joint sealant; ASTM C920, Type S, Grade NS, Class 100/50, Use NT.

2.3 NONSTAINING SILICONE JOINT SEALANTS

- A. Nonstaining Joint Sealants: No staining of substrates when tested according to ASTM C1248.
- B. Silicone, Nonstaining, S, NS, 100/50, NT: Nonstaining, single-component, nonsag, plus 100 percent and minus 50 percent movement capability, nontraffic-use, neutral-curing silicone joint sealant; ASTM C920, Type S, Grade NS, Class 100/50, Use NT.

2.4 MILDEW-RESISTANT JOINT SEALANTS

- A. Mildew-Resistant Joint Sealants: Formulated for prolonged exposure to humidity with fungicide to prevent mold and mildew growth.
- B. Silicone, Mildew Resistant, Acid Curing, S, NS, 25, NT: Mildew-resistant, single-component, nonsag, plus 25 percent and minus 25 percent movement capability, nontraffic-use, acid-curing silicone joint sealant; ASTM C920, Type S, Grade NS, Class 25, Use NT.
- C. Acrylic Latex: Acrylic latex or siliconized acrylic latex, ASTM C834, Type OP, Grade NF.

2.5 MISCELLANEOUS MATERIALS

- A. Primer: Material recommended by joint-sealant manufacturer where required for adhesion of sealant to joint substrates indicated, as determined from preconstruction joint-sealant-substrate tests and field tests.
- B. Cleaners for Nonporous Surfaces: Chemical cleaners acceptable to manufacturers of sealants and sealant backing materials.
- C. Masking Tape: Nonstaining, nonabsorbent material compatible with joint sealants and surfaces adjacent to joints.

PART 3 - EXECUTION

3.1 PREPARATION

- A. Surface Cleaning of Joints: Clean out joints immediately before installing joint sealants to comply with joint-sealant manufacturer's written instructions and the following requirements:
 - 1. Remove laitance and form-release agents from concrete.

**Okaloosa County TDC – Emerald Coast Convention Center
Restroom Renovations and Meeting Room Counters**

2. Clean nonporous joint substrate surfaces with chemical cleaners or other means that do not stain, harm substrates, or leave residues capable of interfering with adhesion.
- B. Joint Priming: Prime joint substrates where recommended by joint-sealant manufacturer or as indicated by preconstruction joint-sealant-substrate tests or prior experience.
- C. Masking Tape: Use masking tape where required to prevent contact of sealant or primer with adjoining surfaces.

3.2 INSTALLATION OF JOINT SEALANTS

- A. General: Comply with ASTM C1193 and joint-sealant manufacturer's written installation instructions for products and applications indicated, unless more stringent requirements apply.
- B. Install sealant backings of kind indicated to support sealants during application and at position required to produce cross-sectional shapes and depths of installed sealants relative to joint widths that allow optimum sealant movement capability.
- C. Install bond-breaker tape behind sealants where sealant backings are not used between sealants and backs of joints.
- D. Install sealants using proven techniques that comply with the following and at the same time backings are installed:
 1. Place sealants so they directly contact and fully wet joint substrates.
 2. Completely fill recesses in each joint configuration.
 3. Produce uniform, cross-sectional shapes and depths relative to joint widths that allow optimum sealant movement capability.
- E. Tooling of Nonsag Sealants: Immediately after sealant application and before skinning or curing begins, tool sealants to form smooth, uniform beads of configuration indicated. Use tooling agents that are approved in writing by sealant manufacturer and that do not discolor sealants or adjacent surfaces.
 1. Provide concave joint profile per Figure 8A in ASTM C1193 unless otherwise indicated.

3.3 FIELD QUALITY CONTROL

- A. Field-Adhesion Testing: Field test joint-sealant adhesion to joint substrates as follows:
 1. Extent of Testing: Test completed and cured sealant joints as follows:
 - a. Perform one test for each 50 feet of joint length.
 2. Test Method: Test joint sealants according to Method A, Field-Applied Sealant Joint Hand Pull Tab, in Appendix X1 in ASTM C1193 or Method A, Tail Procedure, in ASTM C1521.

**Okaloosa County TDC – Emerald Coast Convention Center
Restroom Renovations and Meeting Room Counters**

- B. Evaluation of Field-Adhesion-Test Results: Sealants not evidencing adhesive failure from testing or noncompliance with other indicated requirements will be considered satisfactory. Remove sealants that fail to adhere to joint substrates during testing or to comply with other requirements. Retest failed applications until test results prove sealants comply with indicated requirements.

3.4 JOINT-SEALANT SCHEDULE

- A. Joint-Sealant Application: Interior joints in vertical surfaces and horizontal nontraffic surfaces].
 - 1. Joint Locations:
 - a. Control and expansion joints on exposed interior surfaces of walls.
 - b. Tile control and expansion joints.
 - c. Vertical joints on exposed surfaces of walls and partitions.
 - d. Other joints as indicated on Drawings.
 - 2. Joint-Sealant Color: As selected by Architect from manufacturer's full range of colors.

- B. Joint-Sealant Application: Mildew-resistant interior joints in vertical surfaces and horizontal nontraffic surfaces.
 - 1. Joint Locations:
 - a. Joints between plumbing fixtures and adjoining walls, floors, and counters.
 - b. Tile control and expansion joints where indicated.
 - c. Other joints as indicated on Drawings.
 - 2. Joint-Sealant Color: As selected by Architect from manufacturer's full range of colors.

END OF SECTION 079200

**Okaloosa County TDC – Emerald Coast Convention Center
Restroom Renovations and Meeting Room Counters**

Page Left Blank

**Okaloosa County TDC – Emerald Coast Convention Center
Restroom Renovations and Meeting Room Counters**

SECTION 081113 - HOLLOW METAL DOORS AND FRAMES**PART 1 - GENERAL****1.1 SUMMARY**

- A. Section Includes:
 - 1. Standard hollow metal doors and frames.

1.2 SUBMITTALS

- A. Product Data: For each type of product indicated.
- B. Shop Drawings: Include elevations, door edge details, frame profiles, metal thicknesses, preparations for hardware, and other details.
- C. Schedule: Prepared by or under the supervision of supplier, using same reference numbers for details and openings as those on Drawings.

1.3 QUALITY ASSURANCE

- A. Steel Door and Frame Standard: Comply with ANSI A 250.8, unless more stringent requirements are indicated.

1.4 DELIVERY, STORAGE, AND HANDLING

- A. Deliver doors and frames palletized, wrapped, or crated to provide protection during transit and Project-site storage. Do not use nonvented plastic.
- B. Deliver welded frames with two removable spreader bars across bottom of frames, tack welded to jambs and mullions.

PART 2 - PRODUCTS**2.1 MANUFACTURERS**

- A. Manufacturers: Subject to compliance with requirements, provide products by one of the following:
 - 1. Amweld Building Products, LLC.
 - 2. Ceco Door Products; an Assa Abloy Group company.
 - 3. Steelcraft; an Ingersoll-Rand company.

2.2 MATERIALS

- A. Cold-Rolled Steel Sheet: ASTM A 1008/A 1008M, CS, Type B; suitable for exposed applications.
- B. Hot-Rolled Steel Sheet: ASTM A 1011/A 1011M, CS, Type B, Commercial Steel (CS).
- C. Galvanized Steel Sheets: Shall be manufactured from hot-dipped galvanized steel, G60 zinc coating conforming to ASTM A 525. Galvanized doors shall have galvanized hardware reinforcement.

**Okaloosa County TDC – Emerald Coast Convention Center
Restroom Renovations and Meeting Room Counters**

- D. Frame Anchors: ASTM A 591/A 591M, Commercial Steel (CS), 40Z (12G) coating designation; mill phosphatized.
 - 1. For anchors built into exterior walls, steel sheet complying with ASTM A 1008/A 1008M or ASTM A 1011/A 1011M, hot-dip galvanized according to ASTM A 153/A 153M, Class B.
- E. Inserts, Bolts, and Fasteners: Hot-dip galvanized according to ASTM A 153/A 153M.
- F. Grout: ASTM C 476, except with a maximum slump of 4 inches (102 mm), as measured according to ASTM C 143/C 143M.
- G. Core: Provide manufacturer's standard core for thermally improved doors with maximum U-value of 0.24 btu/hr/sq.ft./degree F (ASTM C236) for all exterior doors.
- H. Glazing: Division 08 Section "Glazing."
- I. Bituminous Coating: Cold-applied asphalt mastic, SSPC-Paint 12, compounded for 15-mil (0.4-mm) dry film thickness per coat. Provide inert-type non-corrosive compound free of asbestos fibers, sulfur components, and other
- J. Finish: All doors, frames and frame components shall be cleaned, phosphatized and finished as standard with one coat of baked-on rust inhibiting prime painted in accordance with the ANSI A224.1 "Test Procedure and Acceptance Criteria for Prime Painted Steel Surfaces for Steel Doors and Frames." Doors and Frames shall be in compliance with 200-hour salt spray and 500-hour humidity test in accordance with ASTM test method B117 "Standard Practice for Operating Salt Spray (Fog) Apparatus" and D1735 "Standard Practice for Testing Water Resistance."

2.3 STANDARD HOLLOW METAL FRAMES

- A. General: ANSI A250.8; concealed fastenings, unless otherwise indicated.
- B. Frame Steel Sheet Thickness:
 - 1. 0.042-inch-thick (18 gage) for wood doors.
- C. Plaster Guards: 0.016-inch- (0.4-mm-) thick, steel sheet plaster guards or mortar boxes to close off interior of openings at mortised cutouts.
- D. Supports and Anchors: Not less than 0.042-inch-(1.0-mm-) thick zinc-coated steel sheet.
 - 1. Masonry Wall Anchors: 0.177-inch- (4.5-mm-) diameter, steel wire complying with ASTM A 510 (ASTM A510M) may be used in place of steel sheet.
- E. Inserts, Bolts, and Fasteners: Manufacturer's standard units. Zinc-coat items that are to be built into exterior walls according to ASTM A 153/A 153M, Class C or D as applicable.

2.4 FRAME ANCHORS

- A. Jamb Anchors:
 - 1. Masonry Type: Adjustable strap-and-stirrup or T-shaped anchors to suit frame size, not less than 0.042 inch (1.0 mm) thick, with corrugated or perforated straps not less than 2 inches (50 mm) wide by 10 inches (250 mm) long; or wire anchors not less than 0.177 inch (4.5 mm) thick.
 - 2. Stud-Wall Type: Designed to engage stud, welded to back of frames; not less than 0.042 inch (1.0 mm) thick.
 - 3. Postinstalled Expansion Type for In-Place Concrete or Masonry: Minimum 3/8-inch-(9.5-mm-) diameter bolts with expansion shields or inserts. Provide pipe spacer from

**Okaloosa County TDC – Emerald Coast Convention Center
Restroom Renovations and Meeting Room Counters**

frame to wall, with throat reinforcement plate, welded to frame at each anchor location.

2.5 STOPS AND MOLDINGS

- A. Fixed Frame Moldings: Formed integral with hollow metal frames, a minimum of **5/8 inch (16 mm)** high unless otherwise indicated. Door lites shall be screw type only.

2.6 ACCESSORIES

- A. Grout Guards: Formed from same material as frames, not less than **0.016 inch (0.4 mm)** thick.

2.7 FABRICATION

- A. Tolerances: Fabricate hollow metal work to tolerances indicated in SDI 117.
- B. Hollow Metal Frames: Where frames are fabricated in sections, provide alignment plates or angles at each joint, fabricated of same thickness metal as frames.
1. Welded Frames: Weld flush face joints continuously; grind, fill, dress, and make smooth, flush, and invisible.
 2. Provide countersunk, flat- or oval-head exposed screws and bolts for exposed fasteners unless otherwise indicated.
 3. Grout Guards: Weld guards to frame at back of hardware mortises in frames to be grouted.
 4. Jamb Anchors: Provide number and spacing of anchors as follows:
 - a. Masonry Type: Locate anchors not more than **18 inches (457 mm)** from top and bottom of frame. Space anchors not more than **32 inches (813 mm)** o.c. and as follows:
 - 1) Three anchors per jamb from **60 to 90 inches (1524 to 2286 mm)** high.
 - b. Stud-Wall Type: Locate anchors not more than **18 inches** from top and bottom of frame. Space anchors not more than **32 inches** o.c. and as follows:
 - 1) Four anchors per jamb from **60 to 90 inches** high.
 - c. Compression Type: Not less than two anchors in each jamb.
 - d. Postinstalled Expansion Type: Locate anchors not more than **6 inches** from top and bottom of frame. Space anchors not more than **26 inches** o.c.
- C. Hardware Preparation: Factory prepare hollow metal work to receive templated mortised hardware according to the Door Hardware Schedule and templates furnished as specified in Division 08 Section "Door Hardware."
1. Locate hardware as indicated, or if not indicated, according to ANSI/SDI A250.8.
 2. Reinforce doors and frames to receive nontemplated, mortised and surface-mounted door hardware.
 3. Comply with applicable requirements in ANSI/SDI A250.6 and ANSI/DHI A115 Series specifications for preparation of hollow metal work for hardware.

**Okaloosa County TDC – Emerald Coast Convention Center
Restroom Renovations and Meeting Room Counters**

2.8 STEEL FINISHES

- A. Prime Finish: Apply manufacturer's standard primer immediately after cleaning and pretreating.
 - 1. Shop Primer: Provide shop applied primer compatible with finish coat specified in Division 09 Painting Sections.

PART 3 - EXECUTION

3.1 INSTALLATION

- A. Hollow Metal Frames: Comply with ANSI/SDI A250.11.
 - 1. Set frames accurately in position, plumbed, aligned, and braced securely until permanent anchors are set. After wall construction is complete, remove temporary braces, leaving surfaces smooth and undamaged.
 - a. At fire-protection-rated openings, install frames according to NFPA 80.
 - b. Where frames are fabricated in sections because of shipping or handling limitations, field splice at approved locations by welding face joint continuously; grind, fill, dress, and make splice smooth, flush, and invisible on exposed faces.
 - c. Install frames with removable glazing stops located on secure side of opening.
 - d. Install door silencers in frames before grouting.
 - e. Remove temporary braces necessary for installation only after frames have been properly set and secured.
 - f. Check plumbness, squareness, and twist of frames as walls are constructed. Shim as necessary to comply with installation tolerances.
 - g. Field apply bituminous coating to backs of frames that are filled with grout containing antifreezing agents.
 - 2. Masonry Walls: Coordinate installation of frames to allow for solidly filling space between frames and masonry with grout.
 - 3. In-Place Concrete or Masonry Construction: Secure frames in place with postinstalled expansion anchors. Countersink anchors, and fill and make smooth, flush, and invisible on exposed faces.
 - 4. In-Place Gypsum Board Partitions: Secure frames in place with postinstalled expansion anchors through floor anchors at each jamb. Countersink anchors, and fill and make smooth, flush, and invisible on exposed faces.
- B. Prior to installation, adjust and securely brace welded hollow metal frames for squareness, alignment, twist, and plumbness to the following tolerances:
 - 1. Squareness: Plus or minus **1/16 inch (1.6 mm)**, measured at door rabbet on a line 90 degrees from jamb perpendicular to frame head.
 - 2. Alignment: Plus or minus **1/16 inch (1.6 mm)**, measured at jambs on a horizontal line parallel to plane of wall.
 - 3. Twist: Plus or minus **1/16 inch (1.6 mm)**, measured at opposite face corners of jambs on parallel lines, and perpendicular to plane of wall.
 - 4. Plumbness: Plus or minus **1/16 inch (1.6 mm)**, measured at jambs on a perpendicular line from head to floor.

**Okaloosa County TDC – Emerald Coast Convention Center
Restroom Renovations and Meeting Room Counters**

3.2 ADJUSTING AND CLEANING

- A. Final Adjustments: Check and readjust operating hardware items immediately before final inspection. Leave work in complete and proper operating condition. Remove and replace defective work, including hollow metal work that is warped, bowed, or otherwise unacceptable.
- B. Prime-Coat Touchup: Immediately after erection, sand smooth rusted or damaged areas of prime coat and apply touchup of compatible air-drying, rust-inhibitive primer.

END OF SECTION 081113

**Okaloosa County TDC – Emerald Coast Convention Center
Restroom Renovations and Meeting Room Counters**

Page left blank

**Okaloosa County TDC – Emerald Coast Convention Center
Restroom Renovations and Meeting Room Counters**

SECTION 081416 - FLUSH WOOD DOORS

PART 1 - GENERAL

1.1 SUMMARY

- A. Section Includes:
 - 1. Five-ply flush wood doors for opaque finish.
 - 2. Factory priming flush wood doors

1.2 ACTION SUBMITTALS

- A. Product Data: For each type of product, including the following:
 - 1. Door core materials and construction.
 - 2. Door edge construction
 - 3. Door face type and characteristics.
 - 4. Door trim for openings.
 - 5. Door frame construction.
 - 6. Factory-machining criteria.
 - 7. Factory-priming specifications.
- B. Shop Drawings: Indicate location, size, and hand of each door; elevation of each type of door; construction details not covered in Product Data; and the following:
 - 1. Door schedule indicating door **and frame** location, type, size, and swing.
 - 2. Door elevations, dimension and locations of hardware, and lite cutouts, and glazing thicknesses.
 - 3. Details of frame for each frame type, including dimensions and profile.
 - 4. Dimensions and locations of blocking for hardware attachment.
 - 5. Clearances and undercuts.
 - 6. Apply AWI Quality Certification Program label to Shop Drawings.

1.3 CLOSEOUT SUBMITTALS

- A. Quality Standard Compliance Certificates: AWI Quality Certification Program certificates.

1.4 QUALITY ASSURANCE

- A. Manufacturer's Certification: Licensed participant in AWI's Quality Certification Program.

**Okaloosa County TDC – Emerald Coast Convention Center
Restroom Renovations and Meeting Room Counters**

PART 2 - PRODUCTS**2.1 PERFORMANCE REQUIREMENTS****2.2 FLUSH WOOD DOORS AND FRAMES, GENERAL**

A. Quality Standard: In addition to requirements specified, comply with ANSI/WDMA I.S. 1A.

1. Provide labels and certificates from AWI certification program indicating that doors and frames comply with requirements of grades specified.

2.3 SOLID-CORE FIVE-PLY FLUSH WOOD DOORS FOR OPAQUE FINISH

A. Interior Solid-Core Doors:

1. Performance Grade:
 - a. ANSI/WDMA I.S. 1A Extra Heavy Duty: public toilets.
2. ANSI/WDMA I.S. 1A Grade: Premium.
3. Faces: Any closed-grain hardwood of mill option.
4. Core for Non-Fire-Rated Doors:
 - a. ANSI A208.1, Grade LD-1 particleboard.
 - 1) Blocking: Provide wood blocking in particleboard-core doors as needed to eliminate through-bolting hardware.
 - b. Either glued wood stave or WDMA I.S. 10 structural composite lumber.
5. Construction: Five plies, hot-pressed bonded (vertical and horizontal edging is bonded to core), with entire unit abrasive planed before veneering.

2.4 LIGHT FRAMES

A. Wood Beads for Light Openings in Wood Doors: Provide manufacturer's standard wood beads unless otherwise indicated.

1. Wood Species: Species compatible with door faces.
2. Profile: Flush rectangular beads.

2.5 FABRICATION

A. Factory fit doors to suit frame-opening sizes indicated.

**Okaloosa County TDC – Emerald Coast Convention Center
Restroom Renovations and Meeting Room Counters**

1. Comply with clearance requirements of referenced quality standard for fitting unless otherwise indicated.
- B. Factory machine doors for hardware that is not surface applied.
 1. Locate hardware to comply with DHI-WDHS-3.
 2. Comply with final hardware schedules, door frame Shop Drawings, ANSI/BHMA-156.115-W, and hardware templates.
 3. Coordinate with hardware mortises in metal frames, to verify dimensions and alignment before factory machining.
- C. Openings: Factory cut and trim openings through doors. Provide lights as indicated on drawings
 1. Light Openings: Trim openings with moldings of material and profile indicated.
 2. Glazing: ¼” tempered frosted: Factory install glazing in doors.

2.6 FACTORY PRIMING

- A. Doors for Opaque Finish: Factory prime faces, all four edges, edges of cutouts, and mortises with one coat of wood primer.

2.7 FACTORY FINISHING

- A. Comply with referenced quality standard for factory finishing.
 1. Complete fabrication, including fitting doors for openings and machining for hardware that is not surface applied, before finishing.
 2. Finish faces, all four edges, edges of cutouts, and mortises.
- B. Opaque Finish:
 1. ANSI/WDMA I.S. 1A Grade: Premium
 2. Finish: Architectural Woodwork Standards System-9, UV Curable, Acrylated Epoxy, Polyester, or Urethane.
 3. Color and Sheen: As selected by Architect from manufacturer's full range.

PART 3 - EXECUTION

3.1 INSTALLATION

- A. Hardware: For installation, see Section 087100 "Door Hardware"
- B. Install doors and frames to comply with manufacturer's written instructions and referenced quality standard, and as indicated.
- C. Install frames level, plumb, true, and straight.

**Okaloosa County TDC – Emerald Coast Convention Center
Restroom Renovations and Meeting Room Counters**

1. Shim as required with concealed shims. Install level and plumb to a tolerance of **1/8 inch in 96 inches (3.2 mm in 2400 mm)**.
2. Anchor frames to anchors or blocking built in or directly attached to substrates.
 - a. Secure with countersunk, concealed fasteners and blind nailing.
 - b. Use fine finishing nails or finishing screws for exposed fastening, countersunk and filled flush with woodwork.
 - 1) For factory-finished items, use filler matching finish of items being installed.

D. Job-Fitted Doors:

1. Align and fit doors in frames with uniform clearances and bevels as indicated below.
 - a. Do not trim stiles and rails in excess of limits set by manufacturer or permitted for fire-rated doors.
2. Machine doors for hardware.
3. Seal edges of doors, edges of cutouts, and mortises after fitting and machining.
4. Clearances:
 - a. Provide **1/8 inch (3.2 mm)** at heads, jambs, and between pairs of doors.
 - b. Provide **1/8 inch (3.2 mm)** from bottom of door to top of decorative floor finish or covering unless otherwise indicated on Drawings.
 - c. Where threshold is shown or scheduled, provide **1/4 inch (6.4 mm)** from bottom of door to top of threshold unless otherwise indicated.
 - d. Comply with NFPA 80 for fire-rated doors.

3.2 FIELD QUALITY CONTROL

- A. Repair or remove and replace installations where inspections indicate that they do not comply with specified requirements.
- B. Reinspect repaired or replaced installations to determine if replaced or repaired door assembly installations comply with specified requirements.

3.3 ADJUSTING

- A. Operation: Rehang or replace doors that do not swing or operate freely.
- B. Finished Doors: Replace doors that are damaged or that do not comply with requirements. Doors may be repaired or refinished if Work complies with requirements and shows no evidence of repair or refinishing.

END OF SECTION 081416

**Okaloosa County TDC – Emerald Coast Convention Center
Restroom Renovations and Meeting Room Counters**

SECTION 083113 - ACCESS DOORS AND FRAMES

PART 1 - GENERAL

1.1 SUMMARY

- A. Section Includes:
 - 1. Access doors and frames for walls and ceilings.

1.2 ACTION SUBMITTALS

- A. Product Data: For each type of product.
- B. Shop Drawings: Include plans, elevations, sections, details, and attachments to other work.
- C. Samples: For each door face material.
- D. Schedule: Types, locations, sizes, latching or locking provisions, and other data pertinent to installation.

PART 2 - PRODUCTS

2.1 PERFORMANCE REQUIREMENTS

- A. Fire-Rated Access Doors and Frames: Units complying with NFPA 80 tested according to the following test method:
 - 1. NFPA 252 or UL 10B for fire-rated access door assemblies installed vertically.
 - 2. NFPA 288 for fire-rated access door assemblies installed horizontally.

2.2 ACCESS DOORS AND FRAMES FOR WALLS AND CEILINGS

- A. Manufacturers: Subject to compliance with requirements, available manufacturers offering products that may be incorporated into the Work include, but are not limited to, the following:
- B. Basis-of-Design Product: Subject to compliance with requirements, provide product indicated or comparable product by one of the following:
 - 1. Acudor Products, Inc.
 - 2. Activar, Inc.
 - 3. Larsen's Manufacturing Company.
 - 4. Milcor Inc.

**Okaloosa County TDC – Emerald Coast Convention Center
Restroom Renovations and Meeting Room Counters**

- C. Source Limitations: Obtain each type of access door and frame from single source from single manufacturer.
- D. Flush Access Doors with Exposed Flanges:
1. Basis-of-Design Product: Milcor Inc
 2. Assembly Description: Fabricate door to fit flush to frame. Provide manufacturer's standard-width exposed flange, proportional to door size.
 3. Locations: Wall.
 4. Uncoated Steel Sheet for Door: 16 gage.
 - a. Finish: Factory prime;
 5. Frame Material: Same material, thickness, and finish as door
 6. Hinges: Manufacturer's standard.
 7. Hardware: Latch.
- E. Flush Access Doors with Concealed Flanges:
1. Basis-of-Design Product: Milcor Inc.
 2. Assembly Description: Fabricate door to fit flush to frame. Provide frame with gypsum board beads for concealed flange installation.
 3. Locations: Ceiling.
 4. Uncoated Steel Sheet for Door: 16 gage
 - a. Finish: Factory prime.
 5. Frame Material: Same material and thickness as door.
 6. Hinges: Manufacturer's standard
 7. Hardware: Latch.
 8. Fire-Rated, Flush Access Doors with Exposed Flanges
- F. Flush Access Doors with Fire Rating
1. Basis-of-Design Product: Activar, Inc.
 2. Assembly Description: Fabricate door to fit flush to frame, with a core of mineral-fiber insulation enclosed in sheet metal. Provide self-latching door with automatic closer and interior latch release. Provide manufacturer's standard-width exposed flange, proportional to door size.
 3. Locations: Wall and ceiling.
 4. Fire-Resistance Rating: Not less than 1 hour or as scheduled.
 5. Temperature-Rise Rating: 450 deg F (250 deg C) at the end of 30 minutes'
 6. Uncoated Steel Sheet for Door: 20 gage.
 7. Finish: Factory prime.
 8. Frame Material: Same material, thickness, and finish as door.
 9. Hinges: Manufacturer's standard.
 10. Hardware: Latch.
 11. Latch: Cam

2.3 FINISHES

- A. Comply with NAAMM's "Metal Finishes Manual for Architectural and Metal Products" for recommendations for applying and designating finishes.

**Okaloosa County TDC – Emerald Coast Convention Center
Restroom Renovations and Meeting Room Counters**

- B. Protect mechanical finishes on exposed surfaces from damage by applying a strippable, temporary protective covering before shipping.
- C. Appearance of Finished Work: Noticeable variations in same piece are not acceptable. Variations in appearance of adjoining components are acceptable if they are within the range of approved Samples and are assembled or installed to minimize contrast.
- D. Steel and Metallic-Coated-Steel Finishes:
 - 1. Factory Prime: Apply manufacturer's standard, fast-curing, lead- and chromate-free, universal primer immediately after surface preparation and pretreatment.

PART 3 - EXECUTION

3.1 INSTALLATION

- A. Comply with manufacturer's written instructions for installing access doors and frames.
- B. Install doors flush with adjacent finish surfaces or recessed to receive finish material.

3.2 ADJUSTING

- A. Adjust doors and hardware, after installation, for proper operation.
- B. Remove and replace doors and frames that are warped, bowed, or otherwise damaged.

END OF SECTION 083113

**Okaloosa County TDC – Emerald Coast Convention Center
Restroom Renovations and Meeting Room Counters**

PAGE LEFT BLANK

**Okaloosa County TDC – Emerald Coast Convention Center
Restroom Renovations and Meeting Room Counters**

SECTION 087100 – DOOR HARDWARE

GENERAL

1.1 SUMMARY:

- A. Section Includes: Finish Hardware for door openings, except as otherwise specified herein.
 - 1. Door hardware for wood doors.
 - 2. Keyed cylinders as indicated.

- B. References: Comply with applicable requirements of the following standards. Where these standards conflict with other specific requirements, the most restrictive shall govern.
 - 1. Builders Hardware Manufacturing Association (BHMA)
 - 2. NFPA 101 Life Safety Code
 - 3. NFPA 80 -Standard for Fire Doors and Other Opening Protectives (2013)
 - 4. ANSI-A156.xx- Various Performance Standards for Finish Hardware
 - 5. UL10C – Positive Pressure Fire Test of Door Assemblies
 - 6. ANSI-A117.1 – Accessible and Usable Buildings and Facilities 2009
 - 7. DHI /ANSI A115.IG – Installation Guide for Doors and Hardware
 - 8. Florida Building Code 2017, 6th Edition

- C. Intent of Hardware Groups
 - 1. Should items of hardware not definitely specified be required for completion of the Work, furnish such items of type and quality comparable to adjacent hardware and appropriate for service required.
 - 2. Where items of hardware are not definitely or correctly specified, are required for completion of the Work, a written statement of such omission, error, or other discrepancy to be submitted to Architect, prior to date specified for receipt of bids for clarification by addendum; or, furnish such items in the type and quality established by this specification, and appropriate to the service intended.

1.2 SUBSTITUTIONS:

- A. Comply with Division 01.

1.3 SUBMITTALS:

- A. Comply with Division 01.

- B. Special Submittal Requirements: Combine submittals of this Section with Sections listed below to ensure the "design intent" of the system/assembly is understood and can be reviewed together.

- C. Product Data: Manufacturer's specifications and technical data including the following:
 - 1. Detailed specification of construction and fabrication.
 - 2. Manufacturer's installation instructions.
 - 3. Wiring diagrams for each electric product specified. Coordinate voltage with electrical before submitting.
 - 4. Submit 6 copies of catalog cuts with hardware schedule.

**Okaloosa County TDC – Emerald Coast Convention Center
Restroom Renovations and Meeting Room Counters**

5. Provide 9001-Quality Management and 14001-Environmental Management for products listed in Materials Section 2.2
- D. Shop Drawings - Hardware Schedule: Submit 6 complete reproducible copy of detailed hardware schedule in a vertical format.
1. List groups and suffixes in proper sequence.
 2. Completely describe door and list architectural door number.
 3. Manufacturer, product name, and catalog number.
 4. Function, type, and style.
 5. Size and finish of each item.
 6. Mounting heights.
 7. Explanation of abbreviations and symbols used within schedule.
 8. Detailed wiring diagrams, specially developed for each opening, indicating all electric hardware, security equipment and access control equipment, and door and frame rough-ins required for specific opening.
- E. Templates: Submit templates and "reviewed Hardware Schedule" to door and frame supplier and others as applicable to enable proper and accurate sizing and locations of cutouts and reinforcing.
1. Templates, wiring diagrams and "reviewed Hardware Schedule" of electrical terms to electrical for coordination and verification of voltages and locations.
- F. Samples: (If requested by the Architect)
1. 1 sample of Lever and Rose/Escutcheon design, (pair).
 2. 3 samples of metal finishes
- G. Contract Closeout Submittals: Comply with Division 01 including specific requirements indicated.
1. Operating and maintenance manuals: Submit 3 sets containing the following.
 - a. Complete information in care, maintenance, and adjustment, and data on repair and replacement parts, and information on preservation of finishes.
 - b. Catalog pages for each product.
 - c. Name, address, and phone number of local representative for each manufacturer.
 - d. Parts list for each product.
 2. Copy of final hardware schedule, edited to reflect, "As installed".
 3. Copy of final keying schedule.
 4. As installed "Wiring Diagrams" for each piece of hardware connected to power, both low voltage and 120 VAC.
 5. One set of special tools required for maintenance and adjustment of hardware, including changing of cylinders.

1.4 QUALITY ASSURANCE

- A. Comply with Division 01.
1. Statement of qualification for distributor and installers.
 2. Statement of compliance with regulatory requirements and single source responsibility.

**Okaloosa County TDC – Emerald Coast Convention Center
Restroom Renovations and Meeting Room Counters**

3. Distributor's Qualifications: Firm with 3 years experience in the distribution of commercial hardware.
 - a. Distributor to employ full time Architectural Hardware Consultants (AHC) for the purpose of scheduling and coordinating hardware and establishing keying schedule.
 - b. Hardware Schedule shall be prepared and signed by an AHC.
 4. Installer's Qualifications: Firm with 3 years experienced in installation of similar hardware to that required for this Project, including specific requirements indicated.
 5. Single Source Responsibility: Except where specified in hardware schedule, furnish products of only one manufacturer for each type of hardware.
- B. Review Project for extent of finish hardware required to complete the Work. Where there is a conflict between these Specifications and the existing hardware, notify the Architect in writing and furnish hardware in compliance with the Specification unless otherwise directed in writing by the Architect.

1.5 DELIVERY, STORAGE, AND HANDLING

- A. Packing and Shipping: Comply with Division 01.
1. Deliver products in original unopened packaging with legible manufacturer's identification.
 2. Package hardware to prevent damage during transit and storage.
 3. Mark hardware to correspond with "reviewed hardware schedule".
 4. Deliver hardware to door and frame manufacturer upon request.
- B. Storage and Protection: Comply with manufacturer's recommendations.

1.6 PROJECT CONDITIONS:

- A. Coordinate hardware with other work. Furnish hardware items of proper design for use on doors and frames of the thickness, profile, swing, security and similar requirements indicated, as necessary for the proper installation and function, regardless of omissions or conflicts in the information on the Contract Documents.
- B. Review Shop Drawings for doors and entrances to confirm that adequate provisions will be made for the proper installation of hardware.

1.7 WARRANTY:

- A. Refer to Conditions of the Contract
- B. Manufacturer's Warranty:
1. Closers: Ten years
 2. Exit Devices: Three Years
 3. Locksets & Cylinders: Three years
 4. All other Hardware: Two years.

1.8 OWNER'S INSTRUCTION:

- A. Instruct Owner's personnel in operation and maintenance of hardware units.

**Okaloosa County TDC – Emerald Coast Convention Center
Restroom Renovations and Meeting Room Counters**

1.9 MAINTENANCE:

- A. Extra Service Materials: Deliver to Owner extra materials from same production run as products installed. Package products with protective covering and identify with descriptive labels. Comply with Division 01 Closeout Submittals Section.
 - 1. Special Tools: Provide special wrenches and tools applicable to each different or special hardware component.
 - 2. Maintenance Tools: Provide maintenance tools and accessories supplied by hardware component manufacturer.
 - 3. Delivery, Storage and Protection: Comply with Owner’s requirements for delivery, storage and protection of extra service materials.
- B. Maintenance Service: Submit for Owner’s consideration maintenance service agreement for electronic products installed.

PRODUCTS

1.10 MANUFACTURERS:

- A. The following manufacturers are approved subject to compliance with requirements of the Contract Documents. Approval of manufacturers other than those listed shall be in accordance with Division 01.

<u>Item:</u>	<u>Manufacturer:</u>	<u>Approved:</u>
Double Act Closer Pivot set	Dorma	Rixson
Deadbolt	Best	
Cylinders	Best (Cormax)	
Push Plates	Trimco	Burns, Rockwood
Protection Plates	Trimco	Burns, Rockwood
Door Stops	Trimco	Burns, RockwoodHinges Stanley Bommer,

- B. Concealed Overhead Double-Acting Closer:
 - 1. Double acting closer
 - a. For doors up to 250Lbs.
 - b. Closer body shall fit into 1 ¾” x 4” header
 - c. Closer is to be non-handed
 - d. Closer body shall include pressure relief valve to protect closer from damage
 - e. Double acting set shall include mounting channel, cover plate, top arm with channel, bottom arm and floor bearing.
 - 2. Cylindrical Deadbolt:
 - a. Tested and approved by ANSI A156.36, Operational Grade 1,
 - b. Fit modified ANSI A115.3 door preparation
 - c. Provide 9001-Quality Management and 14001-Environmental Management.
 - d. Locksets and cores to be of the same manufacturer to maintain complete lockset warranty.
 - e. 2-3/4 inch (70mm) backset, or 2-3/8 inch backset as needed.
 - f. 1-inch throw deadbolt.
 - g. Provide locksets with 7-pin core.

**Okaloosa County TDC – Emerald Coast Convention Center
Restroom Renovations and Meeting Room Counters**

- C. Door Stops: Provide a dome floor or wall stop for every opening as listed in the hardware sets. Use appropriate stop on all double acting doors
 - 1. Wall stop and floor stop shall be wrought bronze, brass or stainless steel.
 - 2. Provide fastener suitable for wall construction.
 - 3. Coordinate reinforcement of walls where wall stop is specified.
 - 4. Provide dome stops where wall stops are not practical. Provide spacers or carpet riser for floor conditions encountered
- D. Push Plates: Provide with four beveled edges ANSI J301, .050 thickness, size as indicated in hardware set. Furnish oval-head countersunk screws to match finish.
- E. Kickplates: Provide with four beveled edges ANSI J102, 10 inches high by width less 2 inches on single doors and 1 inch on pairs of doors. Furnish oval-head countersunk screws to match finish.

1.11 FINISH:

- A. Designations used in Schedule of Finish Hardware - 3.05, and elsewhere to indicate hardware finishes are those listed in ANSI/BHMA A156.18 including coordination with traditional U.S. finishes shown by certain manufacturers for their products
- B. Powder coat door closers to match other hardware, unless otherwise noted.
- C. Aluminum items shall be finished to match predominant adjacent material. Seals to coordinate with frame color.

1.12 KEYS AND KEYING:

- A. Provide keyed brass construction cores and keys during the construction period. Construction control and operating keys and core shall not be part of the Owner's permanent keying system or furnished in the same keyway (or key section) as the Owner's permanent keying system. Permanent cores and keys (prepared according to the accepted keying schedule) will be furnished to the Owner.
- B. Cylinders, removable and interchangeable core system: Best CORMAX™ Patented 7-pin SFIC. Coordinate with Owner for specific keying requirements.
- C. Permanent keys and cores: Stamped with the applicable key mark for identification. These visual key control marks or codes will not include the actual key cuts. Permanent keys will also be stamped "Do Not Duplicate."
- D. Transmit Grand Master Keys, Master Keys and other Security keys to Owner by Registered Mail, return receipt requested.
- E. Furnish keys in the following quantities:
 - 1. 1 each Grand Master Keys
 - 2. 1 each Master Keys
 - 3. 2 each Change keys each keyed core
 - 4. 5 each Construction Master Keys
 - 5. 1 each Control keys

**Okaloosa County TDC – Emerald Coast Convention Center
Restroom Renovations and Meeting Room Counters**

- F. The Owner, or the Owner's agent, will install permanent cores and return the construction cores to the Hardware Supplier. Construction cores and keys remain the property of the Hardware Supplier.
- G. Keying Schedule: Arrange for a keying meeting, and programming meeting with Architect Owner and hardware supplier, and other involved parties to ensure locksets and locking hardware, are functionally correct and keying and programming complies with project requirements. Furnish 3 typed copies of keying and programming schedule to Architect.

EXECUTION**1.13 EXAMINATION**

- A. Verification of conditions: Examine doors, frames, related items and conditions under which Work is to be performed and identify conditions detrimental to proper and or timely completion.
 - 1. Do not proceed until unsatisfactory conditions have been corrected.

1.14 HARDWARE LOCATIONS:

- A. Mount hardware units at heights indicated in the following publications except as specifically indicated or required to comply with the governing regulations.
 - 1. Recommended Locations for Builder's Hardware for Standard Steel Doors and Frames, by the Door and Hardware Institute (DHI).
 - 2. Recommended locations for Architectural Hardware for flush wood doors (DHI).
 - 3. WDMA Industry Standard I.S.-1A-04, Industry Standard for Architectural wood flush doors.

1.15 INSTALLATION:

- A. Install each hardware item per manufacturer's instructions and recommendations. Do not install surface mounted items until finishes have been completed on the substrate. Set units level, plumb and true to line and location. Adjust and reinforce the attachment substrate as necessary for proper installation and operation.
- B. Conform to local governing agency security ordinance.
- C. Install Conforming to ICC/ANSI A117.1 Accessible and Usable Building and Facilities.
 - 1. Adjust door closer sweep periods so that from the open position of 70 degrees, the door will take at least 3 seconds to move to a point 3 inches from the latch, measured to the landing side of the door.
- D. Installed hardware using the manufacturers fasteners provided. Drill and tap all screw holes located in metallic materials. Do not use "Riv-Nuts" or similar products.

1.16 FIELD QUALITY CONTROL AND FINAL ADJUSTMENT

- A. Contractor/Installers, Field Services: After installation is complete, contractor shall inspect the completed door openings on site to verify installation of hardware is complete and properly adjusted, in accordance with both the Contract Documents and final shop drawings.

**Okaloosa County TDC – Emerald Coast Convention Center
Restroom Renovations and Meeting Room Counters**

1. Check and adjust closers to ensure proper operation.
2. Check locking devices are properly installed and adjusted to ensure proper operation.
 - a. Ensure dead bolts are engaged into strike and hardware is functioning.
3. Report findings, in writing, to architect indicating that all hardware is installed and functioning properly. Include recommendations outlining corrective actions for improperly functioning hardware if required.

1.17 SCHEDULE OF FINISH HARDWARE:

Manufacturer List

<u>Code</u>	<u>Name</u>
BE	Best Access Systems
DM	Dorma Door Controls
TR	Trimco

Finish List

<u>Code</u>	<u>Description</u>
626	Satin Chromium Plated
630	Satin Stainless Steel

Option List

<u>Code</u>	<u>Description</u>
CS	CONCEALED SCREWS (8T ONLY)
BFI	BARRIER FREE OPENING FORCE (5 LB)
CSK	COUNTER SINKING OF KICK and MOP PLATES
B4E-HEAVY-KP	BEVELED 4 EDGES - KICK PLATES

Hardware Sets

SET #1

Doors: 223, 224, 225, 226, 227, 228

1	Deadlock	8T3-7S PATD CS	626	BE
1	Concealed Closer	RTS/04 BFI	626	DM
2	Kick Plate	K0050 8" x 35" B4E-HEAVY-KP CSK	630	TR
2	Push Plate	1001-3	630	TR
2	Door Stop	1214H	626	TR

**Okaloosa County TDC – Emerald Coast Convention Center
Restroom Renovations and Meeting Room Counters**

Page Left Blank

**Okaloosa County TDC – Emerald Coast Convention Center
Restroom Renovations and Meeting Room Counters**

SECTION 092216 - NON-STRUCTURAL METAL FRAMING

PART 1 - GENERAL

1.1 SUMMARY

A. Section Includes:

1. Non-load-bearing steel framing systems for interior partitions.
2. Suspension systems for interior ceilings and soffits.

1.2 ACTION SUBMITTALS

A. Product Data: For each type of product.

1.3 INFORMATIONAL SUBMITTALS

A. Product Certificates: For each type of code-compliance certification for studs and tracks.

1.4 QUALITY ASSURANCE

- A. Code-Compliance Certification of Studs and Tracks: Provide documentation that framing members are certified according to the product-certification program of the Certified Steel Stud Association, the Steel Framing Industry Association or the Steel Stud Manufacturers Association.

PART 2 - PRODUCTS

2.1 FRAMING SYSTEMS

A. Framing Members, General: Comply with ASTM C754 for conditions indicated.

1. Steel Sheet Components: Comply with ASTM C645 requirements for steel unless otherwise indicated.
2. Protective Coating: ASTM A653/A653M, G40 (Z120), hot-dip galvanized unless otherwise indicated.

B. Studs and Tracks: ASTM C645. Use either conventional steel studs and tracks or embossed, high-strength steel studs and tracks.

1. Minimum Base-Steel Thickness: As required by performance requirements for horizontal deflection.
2. Depth: As indicated on Drawings

**Okaloosa County TDC – Emerald Coast Convention Center
Restroom Renovations and Meeting Room Counters**

- C. Slip-Type Head Joints: Where indicated, provide one of the following:
1. Clip System: Clips designed for use in head-of-wall deflection conditions that provide a positive attachment of studs to tracks while allowing minimum vertical movement.
 2. Single Long-Leg Track System: ASTM C645 top track with 2-inch- (51-mm-) deep flanges in thickness not less than indicated for studs, installed with studs friction fit into top track and with continuous bridging located within 12 inches (305 mm) of the top of studs to provide lateral bracing.
 3. Double-Track System: ASTM C645 top outer tracks, inside track with 2-inch- (51-mm-) deep flanges in thickness not less than indicated for studs and fastened to studs, and outer track sized to friction-fit over inner track.
 4. Deflection Track: Steel sheet top track manufactured to prevent cracking of finishes applied to interior partition framing resulting from deflection of structure above; in thickness not less than indicated for studs and in width to accommodate depth of studs.
- D. Flat Strap and Backing Plate: Steel sheet for blocking and bracing in length and width indicated.
1. Minimum Base-Steel Thickness 0.0329 inch (0.836 mm).
- E. Cold-Rolled Channel Bridging: Steel, 0.0538-inch (1.367-mm) minimum base-steel thickness, with minimum 1/2-inch- (13-mm-) wide flanges.
1. Depth: 1-1/2 inches (38 mm).
 2. Clip Angle: Not less than 1-1/2 by 1-1/2 inches (38 by 38 mm), 0.068-inch- (1.72-mm-) thick, galvanized steel.
- F. Hat-Shaped, Rigid Furring Channels: ASTM C645.
1. Minimum Base-Steel Thickness 0.0329 inch (0.836 mm).
 2. Depth: 1-1/2 inches (38 mm).
- G. Z-Shaped Furring: With slotted or nonslotted web, face flange of 1-1/4 inches (32 mm), wall attachment flange of 7/8 inch (22 mm), minimum uncoated-steel thickness of 0.0179 inch (0.455 mm), and depth required to fit insulation thickness indicated.

2.2 SUSPENSION SYSTEMS

- A. Tie Wire: ASTM A641/A641M, Class 1 zinc coating, soft temper, 0.062-inch- (1.59-mm-) diameter wire, or double strand of 0.048-inch- (1.21-mm-) diameter wire.
- B. Hanger Attachments to Concrete:
1. Post-Installed Anchors: Fastener systems with an evaluation report acceptable to authorities having jurisdiction, based on ICC-ES or AC308 as appropriate for the substrate.
 - a. Uses: Securing hangers to structure.
 - b. Material for Interior Locations: Carbon-steel components zinc-plated to comply with ASTM B633 or ASTM F1941 (ASTM F1941M), Class Fe/Zn 5, unless otherwise indicated.

**Okaloosa County TDC – Emerald Coast Convention Center
Restroom Renovations and Meeting Room Counters**

- C. Wire Hangers: ASTM A641/A641M, Class 1 zinc coating, soft temper, 0.16 inch (4.12 mm) in diameter.
- D. Flat Hangers: Steel sheet, 1 by 3/16 inch (25 by 5 mm) by length indicated.
- E. Carrying Channels (Main Runners): Cold-rolled, commercial-steel sheet with a base-steel thickness of 0.0538 inch (1.367 mm) and minimum 1/2-inch- (13-mm-) wide flanges.
 - 1. Depth: 2 inches (51 mm).
- F. Furring Channels (Furring Members):
 - 1. Cold-Rolled Channels: 0.0538-inch (1.367-mm) uncoated-steel thickness, with minimum 1/2-inch- (13-mm-) wide flanges, 3/4 inch (19 mm) deep.
 - 2. Steel Studs and Tracks: ASTM C645.
 - a. Minimum Base-Steel Thickness: 0.0329 inch (0.836 mm).
 - b. Depth: 3-5/8 inches (92 mm).
 - 3. Hat-Shaped, Rigid Furring Channels: ASTM C645, 7/8 inch (22 mm) deep.
 - a. Minimum Base-Steel Thickness: 0.0329 inch (0.836 mm).

2.3 AUXILIARY MATERIALS

- A. General: Provide auxiliary materials that comply with referenced installation standards.
 - 1. Fasteners for Steel Framing: Of type, material, size, corrosion resistance, holding power, and other properties required to fasten steel members to substrates.
- B. Isolation Strip at Exterior Walls:
 - 1. Foam Gasket: Adhesive-backed, closed-cell vinyl foam strips that allow fastener penetration without foam displacement, 1/8 inch (3.2 mm) thick, in width to suit steel stud size.

PART 3 - EXECUTION

3.1 INSTALLATION, GENERAL

- A. Installation Standard: ASTM C754.
 - 1. Gypsum Plaster Assemblies: Also comply with requirements in ASTM C841 that apply to framing installation.
 - 2. Portland Cement Plaster Assemblies: Also comply with requirements in ASTM C1063 that apply to framing installation.
 - 3. Gypsum Veneer Plaster Assemblies: Also comply with requirements in ASTM C844 that apply to framing installation.

**Okaloosa County TDC – Emerald Coast Convention Center
Restroom Renovations and Meeting Room Counters**

4. Gypsum Board Assemblies: Also comply with requirements in ASTM C840 that apply to framing installation.
- B. Install framing and accessories plumb, square, and true to line, with connections securely fastened.
- C. Install supplementary framing, and blocking to support fixtures, equipment services, heavy trim, grab bars, toilet accessories, furnishings, or similar construction.
- D. Install bracing at terminations in assemblies.
- E. Do not bridge building control and expansion joints with non-load-bearing steel framing members. Frame both sides of joints independently.

3.2 INSTALLING FRAMED ASSEMBLIES

- A. Install framing system components according to spacings indicated, but not greater than spacings required by referenced installation standards for assembly types.
- B. Where studs are installed directly against exterior masonry walls or dissimilar metals at exterior walls, install isolation strip between studs and exterior wall.
- C. Install studs so flanges within framing system point in same direction.
- D. Install tracks at floors and overhead supports. Extend framing full height to structural supports or substrates above suspended ceilings except where partitions are indicated to terminate at suspended ceilings. Continue framing around ducts that penetrate partitions above ceiling.
 1. Slip-Type Head Joints: Where framing extends to overhead structural supports, install to produce joints at tops of framing systems that prevent axial loading of finished assemblies.
 2. Door Openings: Screw vertical studs at jambs to jamb anchor clips on door frames; install track section (for cripple studs) at head and secure to jamb studs.
 - a. Install two studs at each jamb unless otherwise indicated.
 - b. Install cripple studs at head adjacent to each jamb stud, with a minimum 1/2-inch (13-mm) clearance from jamb stud to allow for installation of control joint in finished assembly.
 - c. Extend jamb studs through suspended ceilings and attach to underside of overhead structure.
 3. Other Framed Openings: Frame openings other than door openings the same as required for door openings unless otherwise indicated. Install framing below sills of openings to match framing required above door heads.
 4. Fire-Resistance-Rated Partitions: Install framing to comply with fire-resistance-rated assembly indicated and support closures and to make partitions continuous from floor to underside of solid structure.

**Okaloosa County TDC – Emerald Coast Convention Center
Restroom Renovations and Meeting Room Counters**

- a. Firestop Track: Where indicated, install to maintain continuity of fire-resistance-rated assembly indicated.
5. Sound-Rated Partitions: Install framing to comply with sound-rated assembly indicated.
6. Curved Partitions:
 - a. Bend track to uniform curve and locate straight lengths so they are tangent to arcs.
 - b. Begin and end each arc with a stud, and space intermediate studs equally along arcs. On straight lengths of no fewer than two studs at ends of arcs, place studs 6 inches (150 mm) o.c.
- E. Direct Furring:
 1. Screw to wood framing.
 2. Attach to concrete or masonry with stub nails, screws designed for masonry attachment, or powder-driven fasteners spaced 24 inches (610 mm) o.c.
- F. Z-Shaped Furring Members:
 1. Erect insulation, specified in Section 072100 "Thermal Insulation," vertically and hold in place with Z-shaped furring members spaced [24 inches (610 mm)] <Insert dimension> o.c.
 2. Except at exterior corners, securely attach narrow flanges of furring members to wall with concrete stub nails, screws designed for masonry attachment, or powder-driven fasteners spaced 24 inches (610 mm) o.c.
 3. At exterior corners, attach wide flange of furring members to wall with short flange extending beyond corner; on adjacent wall surface, screw-attach short flange of furring channel to web of attached channel. At interior corners, space second member no more than 12 inches (305 mm) from corner and cut insulation to fit.
- G. Installation Tolerance: Install each framing member so fastening surfaces vary not more than 1/8 inch (3 mm) from the plane formed by faces of adjacent framing.

3.3 INSTALLING CEILING SUSPENSION SYSTEMS

- A. Install suspension system components according to spacings indicated, but not greater than spacings required by referenced installation standards for assembly types.
- B. Isolate suspension systems from building structure where they abut or are penetrated by building structure to prevent transfer of loading imposed by structural movement.
- C. Suspend hangers from building structure as follows:
 1. Install hangers plumb and free from contact with insulation or other objects within ceiling plenum that are not part of supporting structural or suspension system.
 - a. Splay hangers only where required to miss obstructions and offset resulting horizontal forces by bracing, countersplaying, or other equally effective means.

**Okaloosa County TDC – Emerald Coast Convention Center
Restroom Renovations and Meeting Room Counters**

2. Where width of ducts and other construction within ceiling plenum produces hanger spacings that interfere with locations of hangers required to support standard suspension system members, install supplemental suspension members and hangers in the form of trapezes or equivalent devices.
 - a. Size supplemental suspension members and hangers to support ceiling loads within performance limits established by referenced installation standards.
 3. Wire Hangers: Secure by looping and wire tying, either directly to structures or to inserts, eye screws, or other devices and fasteners that are secure and appropriate for substrate, and in a manner that will not cause hangers to deteriorate or otherwise fail.
 4. Flat Hangers: Secure to structure, including intermediate framing members, by attaching to inserts, eye screws, or other devices and fasteners that are secure and appropriate for structure and hanger, and in a manner that will not cause hangers to deteriorate or otherwise fail.
 5. Do not attach hangers to steel roof deck.
 6. Do not attach hangers to permanent metal forms. Furnish cast-in-place hanger inserts that extend through forms.
 7. Do not attach hangers to rolled-in hanger tabs of composite steel floor deck.
 8. Do not connect or suspend steel framing from ducts, pipes, or conduit.
- D. Installation Tolerances: Install suspension systems that are level to within 1/8 inch in 12 feet (3 mm in 3.6 m) measured lengthwise on each member that will receive finishes and transversely between parallel members that will receive finishes.

END OF SECTION 092216

**Okaloosa County TDC – Emerald Coast Convention Center
Restroom Renovations and Meeting Room Counters**

SECTION 092900 - GYPSUM BOARD

PART 1 - GENERAL

1.1 SUMMARY

A. Section Includes:

1. Interior gypsum board.
2. Tile backing panels.

1.2 ACTION SUBMITTALS

- A. Product Data: For each type of product.

PART 2 - PRODUCTS

2.1 GYPSUM BOARD, GENERAL

- A. Size: Provide maximum lengths and widths available that will minimize joints in each area and that correspond with support system indicated.

2.2 INTERIOR GYPSUM BOARD

- A. Gypsum Board, Type X: ASTM C1396/C1396M.
1. Thickness: 5/8 inch (15.9 mm).
 2. Long Edges: Tapered and featured (rounded or beveled) for prefilling.
- B. Mold-Resistant Gypsum Board: ASTM C1396/C1396M. With moisture- and mold-resistant core and paper surfaces.
1. Core: 5/8 inch (15.9 mm), Type X]
 2. Long Edges: Tapered.
 3. Mold Resistance: ASTM D3273, score of 10 as rated according to ASTM D3274.

2.3 TILE BACKING PANELS

- A. Glass-Mat, Water-Resistant Backing Board: ASTM C1178/C1178M, with manufacturer's standard edges.
1. Core: 5/8 inch (15.9 mm), Type X.
 2. Mold Resistance: ASTM D3273, score of 10 as rated according to ASTM D3274.

**Okaloosa County TDC – Emerald Coast Convention Center
Restroom Renovations and Meeting Room Counters**

2.4 TRIM ACCESSORIES

- A. Interior Trim: ASTM C1047.
 - 1. Material: Galvanized or aluminum-coated steel sheet, rolled zinc, plastic, or paper-faced galvanized-steel sheet.
 - 2. Shapes:
 - a. LC-Bead: J-shaped; exposed long flange receives joint compound.
 - b. L-Bead: L-shaped; exposed long flange receives joint compound.
 - c. U-Bead: J-shaped; exposed short flange does not receive joint compound.
 - d. Expansion (control) joint.

2.5 JOINT TREATMENT MATERIALS

- A. General: Comply with ASTM C475/C475M.
- B. Joint Tape:
 - 1. Interior Gypsum Board: Paper.
 - 2. Glass-Mat Gypsum Sheathing Board: 10-by-10 glass mesh.
 - 3. Tile Backing Panels: As recommended by panel manufacturer.
- C. Joint Compound for Interior Gypsum Board: For each coat, use formulation that is compatible with other compounds applied on previous or for successive coats.
 - 1. Prefilling: At open joints and damaged surface areas, use setting-type taping compound.
 - 2. Embedding and First Coat: For embedding tape and first coat on joints, fasteners, and trim flanges, use drying-type, all-purpose compound.
 - a. Use setting-type compound for installing paper-faced metal trim accessories.
 - 3. Fill Coat: For second coat, use drying-type, all-purpose compound.
 - 4. Finish Coat: For third coat, use drying-type, all-purpose compound.
 - 5. Skim Coat: For final coat of Level 5 finish, use drying-type, all-purpose compound.
- D. Joint Compound for Tile Backing Panels:
 - 1. Glass-Mat, Water-Resistant Backing Panel: As recommended by backing panel manufacturer.

2.6 AUXILIARY MATERIALS

- A. General: Provide auxiliary materials that comply with referenced installation standards and manufacturer's written instructions.
- B. Laminating Adhesive: Adhesive or joint compound recommended for directly adhering gypsum panels to continuous substrate.

**Okaloosa County TDC – Emerald Coast Convention Center
Restroom Renovations and Meeting Room Counters**

- C. Steel Drill Screws: ASTM C1002 unless otherwise indicated.
 - 1. Use screws complying with ASTM C954 for fastening panels to steel members from 0.033 to 0.112 inch (0.84 to 2.84 mm) thick.
 - 2. For fastening cementitious backer units, use screws of type and size recommended by panel manufacturer.
- D. Thermal Insulation: As specified in Section 072100 "Thermal Insulation."

PART 3 - EXECUTION

3.1 APPLYING AND FINISHING PANELS

- A. Examine panels before installation. Reject panels that are wet, moisture damaged, and mold damaged.
- B. Comply with ASTM C840.
- C. Isolate perimeter of gypsum board applied to non-load-bearing partitions at structural abutments. Provide 1/4- to 1/2-inch- (6.4- to 12.7-mm-) wide spaces at these locations and trim edges with edge trim where edges of panels are exposed. Seal joints between edges and abutting structural surfaces with acoustical sealant.
- D. For trim with back flanges intended for fasteners, attach to framing with same fasteners used for panels. Otherwise, attach trim according to manufacturer's written instructions.
- E. Prefill open joints and damaged surface areas.
- F. Apply joint tape over gypsum board joints, except for trim products specifically indicated as not intended to receive tape.
- G. Gypsum Board Finish Levels: Finish panels to levels indicated below and according to ASTM C840:
 - 1. Level 1: Ceiling plenum areas, concealed areas.
 - 2. Level 2: Panels that are substrate for tile.
 - 3. Level 5: Exposed walls.
- H. Glass-Mat Faced Panels: Finish according to manufacturer's written instructions.
- I. Cementitious Backer Units: Finish according to manufacturer's written instructions.

**Okaloosa County TDC – Emerald Coast Convention Center
Restroom Renovations and Meeting Room Counters**

3.2 PROTECTION

- A. Protect installed products from damage from weather, condensation, direct sunlight, construction, and other causes during remainder of the construction period.
- B. Remove and replace panels that are wet, moisture damaged, and mold damaged.

END OF SECTION 092900

**Okaloosa County TDC – Emerald Coast Convention Center
Restroom Renovations and Meeting Room Counters**

SECTION 093013 - CERAMIC TILING

PART 1 - GENERAL

1.1 SUMMARY

- A. Section Includes:
 - 1. Porcelain floor and wall tile.
 - 2. Tile backing panels.
 - 3. Waterproof membrane for thinset applications.
 - 4. Crack isolation membrane.
 - 5. Metal edge strips.

1.2 ACTION SUBMITTALS

- A. Product Data: For each type of product.
- B. Samples:
 - 1. Each type and composition of tile and for each color and finish required.

1.3 INFORMATIONAL SUBMITTALS

- A. Qualification Data: For Installer.

1.4 MAINTENANCE MATERIAL SUBMITTALS

- A. Furnish extra materials that match and are from same production runs as products installed and that are packaged with protective covering for storage and identified with labels describing contents.
 - 1. Tile and Trim Units: Furnish quantity of full-size units equal to 3 percent of amount installed for each type, composition, color, pattern, and size indicated.

1.5 QUALITY ASSURANCE

- A. Installer Qualifications:
 - 1. Installer is a Five-Star member of the National Tile Contractors Association.
 - 2. Installer's supervisor for Project holds the International Masonry Institute's Foreman Certification.

**Okaloosa County TDC – Emerald Coast Convention Center
Restroom Renovations and Meeting Room Counters**

3. Installer employs only Ceramic Tile Education Foundation Certified Installers for Project.
 4. Installer employs at least one installer for Project that has completed the Advanced Certification for Tile Installers (ACT) certification for installation of membranes porcelain tile and large format tile.
- B. Mockups: Build mockups to verify selections made under Sample submittals and to demonstrate aesthetic effects and set quality standards for materials and execution.
1. Subject to compliance with requirements, approved mockups may become part of the completed Work if undisturbed at time of Substantial Completion.

PART 2 - PRODUCTS

2.1 PRODUCTS, GENERAL

- A. ANSI Ceramic Tile Standard: Provide Standard-grade tile that complies with ANSI A137.1 for types, compositions, and other characteristics indicated.
- B. ANSI Standards for Tile Installation Materials: Provide materials complying with ANSI A108.02, ANSI standards referenced in other Part 2 articles, ANSI standards referenced by TCNA installation methods specified in tile installation schedules, and other requirements specified.

2.2 TILE PRODUCTS

- A. Porcelain Tile Type PT-1: Porcelain Honed or Lappato floor and wall tile.
 1. Composition: porcelain
 2. Certification: Porcelain tile certified by Urbatek Porcelanosa Group.
 3. Module Size: 12"x 24" or 11 11/16" x 23 7/16"
 4. Thickness: 13/32" thick approx.
 5. Face: Plain [tone variations 3]
 6. Surface: Lappato- slip resistance
 7. Dynamic Coefficient of Friction: Not less than 0.56. Friction wet- 0.56 and Friction when dry 0.75
 8. Finish: Lappato
 9. Tile Color and Pattern: Avenue Grey Lappato 100143115-c220400321
 10. Grout Color: Tac color 929 charcoal grey (or similar)
 11. Trim Units: Coordinated with sizes and coursing of adjoining flat tile where applicable and matching characteristics of adjoining flat tile. Provide shapes as follows, selected from manufacturer's standard shapes:
 - a. Base Cove: Cove, module size
 - b. Base Cap:
 - c. Wainscot Cap:
 - d. Internal Corners:

**Okaloosa County TDC – Emerald Coast Convention Center
Restroom Renovations and Meeting Room Counters**

- a. Tapered Transition Tile: Shape designed to effect transition between thickness of tile floor and adjoining floor finishes of different thickness, tapered to provide reduction in thickness from

2.3 THRESHOLDS

- A. General: Fabricate to sizes and profiles indicated or required to provide transition between adjacent floor finishes.
 1. Bevel edges at 1:2 slope, with lower edge of bevel aligned with or up to **1/16 inch (1.5 mm)** above adjacent floor surface. Finish bevel to match top surface of threshold. Limit height of threshold to **1/4 inch** or less above adjacent floor surface.
- B. Marble Thresholds: ASTM C503/C503M, with a minimum abrasion resistance of **10** according to ASTM C1353 or ASTM C241/C241M and with honed finish.
 1. Description: Uniform, fine- to medium-grained white stone with gray veining.

2.4 TILE BACKING PANELS

- A. Cementitious Backer Units: ANSI A118.9 or ASTM C1325, Type A.
 1. Thickness: **5/8 inch (15.9 mm)**.

2.5 WATERPROOF MEMBRANE

- A. General: Manufacturer's standard product that complies with ANSI A118.10 and is recommended by the manufacturer for the application indicated. Include reinforcement and accessories recommended by manufacturer.

2.6 CRACK ISOLATION MEMBRANE

- A. General: Manufacturer's standard product that complies with ANSI A118.12 for standard performance and is recommended by the manufacturer for the application indicated. Include reinforcement and accessories recommended by manufacturer.

2.7 SETTING MATERIALS

- A. Portland Cement Mortar (Thickset) Installation Materials: ANSI A108.02.
- B. Standard Dry-Set Mortar (Thinset): ANSI A118.1.
 1. For wall applications, provide nonsagging mortar.

**Okaloosa County TDC – Emerald Coast Convention Center
Restroom Renovations and Meeting Room Counters**

2.8 GROUT MATERIALS

- A. Sand-Portland Cement Grout: ANSI A108.10, consisting of white or gray cement and white or colored aggregate as required to produce color indicated.

2.9 MISCELLANEOUS MATERIALS

- A. Trowelable Underlayments and Patching Compounds: Latex-modified, portland cement-based formulation provided or approved by manufacturer of tile-setting materials for installations indicated.
- B. Metal Edge Strips: Angle or L-shape, height to match tile and setting-bed thickness, metallic or combination of metal and PVC or neoprene base, designed specifically for wall and flooring applications
- C. Floor Sealer: Manufacturer's standard product for sealing grout joints and that does not change color or appearance of grout.

PART 3 - EXECUTION

3.1 EXAMINATION

- A. Examine substrates, areas, and conditions where tile will be installed, with Installer present, for compliance with requirements for installation tolerances and other conditions affecting performance of the Work.
 - 1. Verify that substrates for setting tile are firm; dry; clean; free of coatings that are incompatible with tile-setting materials, including curing compounds and other substances that contain soap, wax, oil, or silicone; and comply with flatness tolerances required by ANSI A108.01 for installations indicated.
 - 2. Verify that concrete substrates for tile floors installed with bonded mortar bed or thinset mortar comply with surface finish requirements in ANSI A108.01 for installations indicated.
- B. Proceed with installation only after unsatisfactory conditions have been corrected.

3.2 PREPARATION

- A. Fill cracks, holes, and depressions in concrete substrates for tile floors installed with thinset mortar with trowelable leveling and patching compound specifically recommended by tile-setting material manufacturer.
- B. Where indicated, prepare substrates to receive waterproof membrane by applying a reinforced mortar bed that complies with ANSI A108.1A and is sloped **1/4 inch per foot (1:50)** toward drains.

**Okaloosa County TDC – Emerald Coast Convention Center
Restroom Renovations and Meeting Room Counters**

- C. Blending: For tile exhibiting color variations, verify that tile has been factory blended and packaged so tile units taken from one package show same range of colors as those taken from other packages and match approved Samples. If not factory blended, either return to manufacturer or blend tiles at Project site before installing.

3.3 INSTALLATION

- A. Comply with TCNA's "Handbook for Ceramic, Glass, and Stone Tile Installation" for TCNA installation methods specified in tile installation schedules. Comply with parts of the ANSI A108 series "Specifications for Installation of Ceramic Tile" that are referenced in TCNA installation methods, specified in tile installation schedules, and apply to types of setting and grouting materials used.
1. For the following installations, follow procedures in the ANSI A108 series of tile installation standards for providing 95 percent mortar coverage:
 - a. Tile floors in wet areas.
 - b. Tile floors consisting of tiles **8 by 8 inches (200 by 200 mm)** or larger.
- B. Extend tile work into recesses and under or behind equipment and fixtures to form complete covering without interruptions unless otherwise indicated. Terminate work neatly at obstructions, edges, and corners without disrupting pattern or joint alignments.
- C. Accurately form intersections and returns. Perform cutting and drilling of tile without marring visible surfaces. Carefully grind cut edges of tile abutting trim, finish, or built-in items for straight aligned joints. Fit tile closely to electrical outlets, piping, fixtures, and other penetrations so plates, collars, or covers overlap tile.
- D. Provide manufacturer's standard trim shapes where necessary to eliminate exposed tile edges.
- E. Where accent tile differs in thickness from field tile, vary setting bed thickness so that tiles are flush.
- F. Jointing Pattern: Lay tile in grid pattern unless otherwise indicated. Lay out tile work and center tile fields in both directions in each space or on each wall area. Lay out tile work to minimize the use of pieces that are less than half of a tile. Provide uniform joint widths unless otherwise indicated.
- G. Joint Widths: Unless otherwise indicated, install tile with the following joint widths:
1. Ceramic Mosaic Tile: **1/16 inch (1.6 mm)**.
 2. Porcelain Tile: **1/4 inch (6.4 mm)**.
- H. Expansion Joints: Provide expansion joints and other sealant-filled joints, including control, contraction, and isolation joints, where indicated. Form joints during installation of setting materials, mortar beds, and tile. Do not saw-cut joints after installing tiles.
1. Where joints occur in concrete substrates, locate joints in tile surfaces directly above them.

**Okaloosa County TDC – Emerald Coast Convention Center
Restroom Renovations and Meeting Room Counters**

- I. Stone Thresholds: Install stone thresholds in same type of setting bed as adjacent floor unless otherwise indicated.
 - 1. At locations where mortar bed (thickset) would otherwise be exposed above adjacent floor finishes, set thresholds in modified dry-set mortar (thinset).
 - 2. Do not extend waterproof membrane or [crack isolation membrane under thresholds set in standard dry-set mortar. Fill joints between such thresholds and adjoining tile set on waterproof membrane or crack isolation membrane with elastomeric sealant.
- J. Metal Edge Strips: Install at locations indicated. Schluter metal transition strips at wall and floor transition. Schluter metal edge protection at outside corners.
- K. Floor Sealer: Apply floor sealer to cementitious grout joints in tile wall and floors] according to floor-sealer manufacturer's written instructions. As soon as floor sealer has penetrated grout joints, remove excess sealer and sealer from tile faces by wiping with soft cloth.
- L. Install tile backing panels and treat joints according to ANSI A108.11 and manufacturer's written instructions for type of application indicated. Use modified dry-set mortar for bonding material unless otherwise directed in manufacturer's written instructions.
- M. Install waterproof membrane to comply with ANSI A108.13 and manufacturer's written instructions to produce waterproof membrane of uniform thickness that is bonded securely to substrate.
- N. Install crack isolation membrane to comply with ANSI A108.17 and manufacturer's written instructions to produce membrane of uniform thickness that is bonded securely to substrate.

3.4 INTERIOR CERAMIC TILE INSTALLATION SCHEDULE

- A. Interior Floor Installations, Concrete Subfloor:
 - 1. Ceramic Tile Installation: TCNA F111 and ANSI A108.1A; cement mortar bed (thickset) with cleavage membrane.
 - a. Bond Coat for Cured-Bed Method: Standard dry-set mortar.
 - b. Grout: Sand-portland cement.
- B. Interior Wall Installations, Wood or Metal Studs or Furring:
 - 1. Ceramic Tile Installation: TCNA W221 and ANSI A108.1A over waterproof membrane on solid backing.
 - a. Bond Coat for Wet-Set Method: Standard dry-set mortar.
 - b. Grout: Sand-portland cement.

END OF SECTION 093013

**Okaloosa County TDC – Emerald Coast Convention Center
Restroom Renovations and Meeting Room Counters**

SECTION 093123 – Thin-Set Glass Mosaic Tiling

PART 1 - GENERAL

1.1 SUMMARY

- A. Section Includes:
 - 1. Mosaic glass tile.
 - 2. Surface preparation products.
 - 3. Tile setting mortars and adhesives.
 - 4. Grout for tile.
 - 5. Waterproofing membrane for tile

1.2 ACTION SUBMITTALS

- A. Product Data: For each type of product.
- B. Manufacturer Installation Instructions
- C. Samples:
 - 1. Each type and composition of tile and for each color and finish required.
 - 2. Assembled samples mounted on a rigid panel, with grouted joints, for each type and composition of tile and for each color and finish required.

1.3 INFORMATIONAL SUBMITTALS

- A. Qualification Data: For Installer.

1.4 MAINTENANCE MATERIAL SUBMITTALS

- A. Furnish extra materials that match and are from same production runs as products installed and that are packaged with protective covering for storage and identified with labels describing contents.
 - 1. Tile and Trim Units: Furnish quantity of full-size units equal to 3 percent of amount installed for each type, composition, color, pattern, and size indicated.

1.5 QUALITY ASSURANCE

- A. Installer Qualifications:

**Okaloosa County TDC – Emerald Coast Convention Center
Restroom Renovations and Meeting Room Counters**

1. Installer is a Five-Star member of the National Tile Contractors Association or a Trowel of Excellence member of the Tile Contractors' Association of America.
2. Installer's supervisor for Project holds the International Masonry Institute's Foreman Certification.
3. Installer employs only Ceramic Tile Education Foundation Certified Installers or installers recognized by the U.S. Department of Labor as Journeyman Tile Layers for Project.
4. Installer employs at least one installer for Project that has completed the Advanced Certification for Tile Installers (ACT) certification for installation of mud floors, gauged porcelain tile/gauged porcelain tile panels and large format tile.

B. Source

1. To ensure warranty requirements and compatibility of products; provide all tile grout, setting materials, additives, accessories, and factory-prepared dry-set mortars from the same manufacturer.

C. Mockups: Build mockups to verify selections made under Sample submittals and to demonstrate aesthetic effects and set quality standards for materials and execution.

1. Build mockup of each type of floor tile installation.
2. Build mockup of each type of wall tile installation.
3. Subject to compliance with requirements, approved mockups may become part of the completed Work if undisturbed at time of Substantial Completion.

1.6 DELIVERY, STORAGE AND HANDLING

- A. Deliver and store packaged materials in original containers with seals unbroken and labels intact until time of use. Prevent damage or contamination to materials by water, freezing, foreign matter or other causes.
- B. Do not use frozen materials unless specifically allowed by manufacturer.
- C. Deliver and store materials on site at least 24 hours before work begins.
- D. Provide heated and dry storage facilities on site.

1.7 ENVIRONMENTAL REQUIREMENTS

- A. Comply with requirements of referenced standards and recommendations of material manufacturers for environmental conditions before, during, and after installation.
- B. For interior applications:
 1. Do not begin installation until building is completely enclosed and maintaining temperature and humidity conditions consistent with "after occupancy" conditions for a minimum of 2 weeks.
 2. Maintain continuous and uniform building temperatures of not less than 10 degrees C (50 degrees F) during installation.

**Okaloosa County TDC – Emerald Coast Convention Center
Restroom Renovations and Meeting Room Counters**

3. Ventilate spaces receiving tile in accordance with material manufacturer's instruction.

PART 2 - PRODUCTS

2.1 MANUFACTURERS

- A. MAPEI, Inc. Canada, 2900 Francis-Hughes, Laval, PQ, Canada, H7L3J5. Toll Free Tel: 800-361-9309; Tel: 450-662-1212; Fax: 450-662-0444; Email: TServicesCA@mapei.com; Web: www.mapei.ca.
- B. MAPEI Americas U.S.A., 1144 E. Newport Center Rd., Deerfield Beach, FL 33442; ASD. Toll Free Tel: 800-42-MAPEI; Tel: 954-246-8888; Fax: 954-246-8801; Email: mapeitechsvcs@mapei.com; Web: www.mapei.us.
- C. Substitutions: Not permitted.

2.2 SUBSTRATE MATERIALS

- A. Steel Framing: Non-corrosive load-bearing C-type steel studs conforming to ASTM C955 and rigid furring channels for screw application of Cementitious Backer Unit. Minimum base metal thickness and individual measurement shall be not less than 20 Gauge (0.84 mm or 0.033 inch).
- B. Water Resistant Gypsum Backing Board: Glass-Mat, Water-Resistant Backing Board: ASTM C1178/C1178M, with manufacturer's standard edges.
 1. Core: 5/8 inch (15.9 mm), Type X.
 2. Mold Resistance: ASTM D3273, score of 10 as rated according to ASTM D3274.

2.3 GLASS TILE

- A. Impervious Glass Mosaic Tiles: Bodesi glass mosaics, face-mounted (4x12, Hand painted series, color Peacock 80), as manufactured in Canada by Bodesi Glass Tile, 2076 192 St #104, Surrey, BC V3Z 0N2 and provided in Canada by manufacturer Bodesi Tile. Bo Wojityra, 1 888 658 2488, Info@bodesi.com

2.4 WALL RENDERING MORTAR

- A. MAPEI's Planitop 330 Fast, quick-setting, fiber-reinforced, cementitious rendering mortar applied from 3 mm to 3.2 cm (0.125 inch to 1.25 inches) thick.

**Okaloosa County TDC – Emerald Coast Convention Center
Restroom Renovations and Meeting Room Counters**

2.5 SELF-LEVELING UNDERLAYMENTS

- A. MAPEI's Novoplan 2 Plus, professional self-leveling underlayment for smoothing and repairing interior floors before the installation of floor coverings applied from 3 mm to 2.5 cm (0.125 inch to 1 inch) thick. Requires a MAPEI primer.
- B. MAPEI's Ultraplan 1 Plus, high-performance, quick-setting, self-leveling underlayment, for smoothing and repairing interior floors before the installation of floor coverings applied from featheredge to 3.8 cm (1.5 inch) thick. Requires a MAPEI primer.

2.6 SELF-LEVELING UNDERLAYMENT AND GYPSYM DRYWALL LATEX PRIMER

- A. MAPEI's Primer T, all-purpose, low odor primer.

2.7 WATERPROOFING MEMBRANE

- A. MAPEI's Mapelastic 315, trowel-applied professional cement-based waterproofing complying with ANSI A118.10 and having IAPMO certification as a shower pan liner.
 - 1. MAPEI's Fiberglass Mesh, ready-to-use, strong, flexible, alkali-resistant mesh for embedment with waterproofing and crack-isolation membranes.

2.8 GROUTS:

- a. Mapei color: 93 Warm Gray (or similar)
- b. Alternate option: Tec Color- 949 Silverado
- B. MAPEI's Keracolor U, unsanded polymer-modified Portland cement ceramic tile grout, complying with ANSI A118.6 and ISO 13007 CG2WA, for joints between 1.5 mm and 3 mm (0.0625 inch to 0.125 inch) wide.
 - 1. Color: TBD Mapei 93 warm grey or similar.

TILE-SETTING MORTARS

- C. MAPEI's Adesilex P10, single-component, bright white, polymer-modified thin-set glass tile mortar with non-sag properties; complying with ANSI A118.4 and ISO 13007 C2TE.
 - 1. Can be mixed with MAPEI's Keraply in lieu of water; complying with ANSI A118.4, ANSI A118.11 and ISO 13007 C2TES1P1.

2.9 FLEXIBLE SEALANT

- A. MAPEI's Mapesil T, professional-grade, 100-percent silicone sealant specifically formulated for heavy traffic for expansion/movement joints complying with ASTM standards; slump (ASTM C639), Tack-Free time (ASTM C679,) shore "A" hardness (ASTM C661), joint movement (ASTM C920), elongation at break (ASTM D412), flexibility (ASTM C734) and passes weatherability (Accelerated Weathering Tester QUV).

**Okaloosa County TDC – Emerald Coast Convention Center
Restroom Renovations and Meeting Room Counters**

B. MIXES

1. Proportion and mix materials in accordance with manufacturer's most current written instructions.

PART 3 - EXECUTION

3.1 EXAMINATION

- A.** Examine substrates, areas, and conditions where tile will be installed, with Installer present, for compliance with requirements for installation tolerances and other conditions affecting performance of the Work.

1. Verify that substrates for setting tile are firm; dry; clean; free of coatings that are incompatible with tile-setting materials, including curing compounds and other substances that contain soap, wax, oil, or silicone; and comply with flatness tolerances required by ANSI A108.01 for installations indicated.
2. The concrete substrate shall be completely cured, solid, sound and shall have a direct tensile cohesive strength greater than 1.21 MPa (175 psi) when tested in accordance with ACI 503R Appendix A procedure.
3. Concrete must not exceed a Water Vapour Emission Rate (MVER) of 1.36 kg per 92.9 square metres (3 pounds per 1000 square feet) per 24 hours when tested per ASTM F1869 or a Relative Humidity (RH) not exceeding 75 percent when tested per ASTM F2170. When Mapelastic AquaDefense is used, the MVER limit is 3.63 kg per 92.9 square metres (8 pounds per 1000 square feet) per 24 hours when tested per ASTM F1869 and the RH limit is 85 percent when tested per ASTM F2170.
4. On-grade or below-grade concrete slabs must be installed over an effective vapour barrier. The on-going presence of free water under the bottom of the surface of the tile must be avoided in order to prevent the unleashing of potentially damaging chemical reaction or staining.
5. Prior to installation, set aside for further inspection and replacement on a tile for tile basis by the tile supplier, all sub-standard tiles, fractured tiles or tiles with chipped corners, pinholes or voids that are unusable for cuts. The installer shall replace at his own expense, without any charge to the architect, owner, tile supplier or manufacturer, all sub-standard and pre-damaged tiles once they are installed.
6. Carefully select, set aside and shade-mix the tiles to a homogeneous blend throughout. During installation, provide supplementary lighting equipment if necessary to easily identify shade differences, which are normally very slight or inexistent, and provide a standard even aesthetic blend effect. This is best achieved by using a strong floodlight or spotlight fitted to a movable pole stand immediately over the work area.
7. Before setting, examine tile backs for possible dust or other contaminants. If necessary, use a slightly damp towel and wipe the tile backs to remove any such dust or contaminant residue.

- B.** Proceed with installation only after unsatisfactory conditions have been corrected.

**Okaloosa County TDC – Emerald Coast Convention Center
Restroom Renovations and Meeting Room Counters**

3.2 PREPARATION

A. Concrete:

1. Perform surface preparation in compliance with the most recent ICRI Technical Guideline No. 310.2R. Concrete must be clean and textured. All oil, dirt, debris, paint and unsound concrete must be removed. The surface must be prepared mechanically using a diamond-cup grinder or other engineer-approved methods, to produce a surface profile matching CSP 3 per ICRI 310.2R.
2. If the concrete is excessively dry or porous, pre-moisten the concrete substrate before work begins. Remove all excess water or standing water allowing the surface to become saturated surface dry (SSD) before installing the leveling coat or tile-setting mortar.

B. Gypsum Drywall Panels:

1. Prime the substrate surface with Primer T (diluted to a 2 parts of water per 1 part of Primer T) using a 10 mm (0.375 inch) nap roller. Let dry for 3 to 4 hours.

C. If wall rendering is required:

1. If installing over concrete walls or cement-block masonry walls, the substrate surface must be clean and porous with a minimum concrete surface profile (CSP) of 2. Substrate surfaces should be saturated surface-dry (SSD).
2. If installing over new gypsum wallboard or substrate containing gypsum patching compound, prime the substrate surface with Primer T (diluted to a 2 parts of water per 1 part of Primer T) using a 10 mm (0.375 inch) nap roller. Let dry for 3 to 4 hours.
3. Apply a thin skimcoat/bonding layer of Planitop 330 Fast into the substrate with a flat trowel. Immediately apply a build layer of Planitop 330 Fast into the fresh skimcoat at the thickness required to level and even the substrate in a single layer, up to a maximum of 3.2 cm (1.25 inches).
4. Let Planitop 330 Fast cure for at least 24 hours based at 21 degrees C (70 degrees F) before applying a waterproofing membrane or setting tiles.

D. If floor leveling is required:

1. The substrate surface temperature must be at least 2.8 degrees C (5 degrees F) above the dew point to avoid condensation on the substrate surface as Primer T dries.
2. On absorbent surfaces, dilute Primer T with water at a ratio of 1:1 to 2:1 (water to primer). On non-absorbent surfaces, use Primer T undiluted.
3. Apply Primer T with a 10 mm (0.375 inch) nap roller working it into the surface. Do not puddle.
4. Let dry 3 hours and up to 24 hours based at 23 degrees C (73 degrees F) before application of a self-leveling underlayment. If the primer remains uncovered for more than 24 hours, re-apply a second undiluted coat and install the self-leveling underlayment within the correct application window.
5. Close doors and windows and turn off HVAC systems to prevent drafts during application and until the self-leveling underlayment is cured. Adjust ventilation system to prevent air movement across surface. Protect areas from direct sunlight.
6. Quickly pour the mixed self-leveling underlayment onto the properly prepared and primed surface in a ribbon pattern.
7. Set the width of the pour at a distance that is ideal for maintaining a wet edge throughout placement and in consideration of expansion and control joints.

**Okaloosa County TDC – Emerald Coast Convention Center
Restroom Renovations and Meeting Room Counters**

8. Provide a continuous flow of wet material which will help to prevent trapping air or creating a cold joint.
9. Shortly after placing the self-leveling underlayment, spread the material with a gauge rake to assist in gauging out the self-leveling underlayment to the desired depth. After achieving the desired depth, smooth the surface with a smoother to obtain evenness.
10. All existing expansion joints, isolation joints, construction joints and control joints, as well as any moving cracks, must be honored up through the self-leveling underlayment.
11. Let Novoplan 2 Plus cure for 24 hours before installing tile or 48 to 72 hours before installing a waterproofing membrane based at 21 degrees C (70 degrees F) Let Ultraplan 1 Plus cure 3 to 4 hours before installing tile or 16 to 24 hours before installing a waterproofing membrane, based at 21 degrees C (70 degrees F).

3.3 INSTALLATION

A. Waterproofing Membrane:

1. Set aside pre-cut sections of the Reinforcing Fabric.
2. Apply a generous coat of Mapelastic AquaDefense liquid on corners, coves, drains and penetration with a paintbrush. Incorporate MAPEI's Reinforcing Fabric immediately in the fresh coat of Mapelastic AquaDefense and remove the excess of material with an appropriate tool. The Reinforcing Fabric should be bed in the waterproofing membrane at 100 percent and immediately recovered with another coat of Mapelastic AquaDefense. Reinforcing Fabric should be perfectly installed at a 90 degree angle in the corners. When using Reinforcing Fabric avoid air pockets, bubbles or excess of material behind it (see technical data sheet for further instructions). Reinforcing Fabric must be at least 5 cm (2 inches) overlapped during the application process.
3. Apply Mapelastic AquaDefense on the areas to be waterproofed using a 10 mm (0.375 inch) nap roller. Let the Mapelastic AquaDefense dry for 30 to 50 minutes (0.375 inch) nap roller.

B. Mapelastic 315:

1. Set aside pre-cut sections of the Fiberglass Mesh.
2. Key a liberal amount of Mapelastic 315 using the trowel's flat side into the corners, coves, drains and penetration.
3. Immediately apply additional Mapelastic 315 and comb with a 4.5 mm by 4 mm (0.1875 inch by 0.1562 inch) v-notch trowel.
4. Embed the pre-cut sections of Fiberglass Mesh into the fresh Mapelastic 315. Lap all seams and ends in the Fiberglass Mesh by 5 cm (2 inches).
5. Using the trowel's flat side, immediately flatten the material to a smooth, voidless membrane with a thickness of up to 2 mm (0.078 inch).
6. Let the Mapelastic 315 cure 4 to 6 hours based at 23 degrees C (73 degrees F). Install Mapelastic 315 over the entire area to be waterproofed following steps 2 to 5 above.
7. Let the Mapelastic 315 cure 8 to 12 hours based at 23 degrees C (73 degrees F). Apply Mapesil T over the Mapelastic 315 membrane to secure waterproofing accessories (drains, water outlet) to ensure perfect waterproofing.

C. Tile-Setting Mortar:

**Okaloosa County TDC – Emerald Coast Convention Center
Restroom Renovations and Meeting Room Counters**

1. Choose a typical notched trowel with sufficient depth to achieve more than 95 percent mortar contact to both the tile and substrate. It may be necessary to backbutter the tile in order to meet these requirements.
2. With pressure, apply a coat by using the trowel's flat side to key mortar into the substrate. Apply additional mortar, combing it in a single direction with the trowel's notched side. Spread only as much mortar as can be tiled before the product skins over. Open time can vary with jobsite conditions.
3. Place the tiles firmly into the wet mortar. Push the tiles back and forth in a direction perpendicular to trowel lines, to collapse the mortar ridges and to help achieve maximum coverage. Ensure proper contact between mortar, tile, and substrate by periodically lifting a few tiles to check for acceptable coverage.
4. Remove excess mortar from the joint areas so that at least two thirds of the tile depth is available for grouting.
5. Let regular-setting tile mortar cure for at least 24 hours before grouting and fast-setting tile mortar cure for at least 3 to 4 hours before grouting.
6. Provide for expansion and control joints in accordance with TTMAC 301MJ method.

D. Grouting:

1. When grouting with sanded cement grouts, pigmented grouts and epoxy grouts, special care and precautions must be taken to prevent staining, scratching, dulling or otherwise damaging the tile appearance.
2. Keracolor U and Ultracolor Plus FA:
 - a. Force grout into the joints with a rubber grout float. Make sure all joints are well-compacted and free of voids and gaps.
 - b. Remove excess grout from the tile surface, moving the grout float diagonally to the joints while the grout is still fresh.
 - c. The grout surface should be flush with the tile edge.
 - d. Allow the grout to firm up in the joints sufficiently to avoid damaging the grout surface, usually in 15 to 30 minutes, depending upon the temperature, humidity and absorption rate of the tile.
 - e. Use two buckets of cleaning water: one for rinsing the majority of the grout residue from the grout sponge, and one for moistening the sponge in clean water.
 - f. Dip the sponge in a bucket of water and wring out the excess, so that the sponge does not drip water. Using very little pressure, pull the sponge diagonally across the grout joints to remove the excess grout from the tile surface. Also use the sponge to smooth the surface of the grout joint. Turn the sponge over and make another pass in an adjacent area. After using both sides, rinse the sponge in one bucket and wring out the excess water. Dip the sponge in the second bucket of water, wringing out the excess and continue the process.
 - g. Change the water in the buckets frequently to help limit the amount of haze that forms on the tile surface.
 - h. To control color variations, buff the grouted surface with cheesecloth or a clean, dry cotton cloth when a haze is visible on the tile surface, usually 30 to 60 minutes after grouting. This should remove any remaining surface water or grout residue.

E. Kerapoxy CQ:

1. Remove mixed product from the container and place it in small piles. (If grouting a wall, place the product on kraft paper laid on the floor.) Kerapoxy CQ is a thermosetting product, so that it sets up faster in a container or in a large mass.

**Okaloosa County TDC – Emerald Coast Convention Center
Restroom Renovations and Meeting Room Counters**

2. Use a hard-rubber float with a sharp edge to force the grout into the joints in a continuous manner, leaving it flush with the tile edge. Make sure all joints are well-compacted and free of voids and gaps.
 3. Remove excess grout from the tile surface, moving the grout float diagonally to the joints while the grout is still fresh.
 4. Apply a liberal amount of cold water to the freshly grouted area. Scrub the tile surface diagonally to the joint line using a nonwoven nylon white scouring pad (use a more aggressive pad if tile has an abrasive surface). Apply enough pressure on the pad to loosen any film without removing grout from the joints. Rinse pads frequently while cleaning. Be careful not to get any water in the ungrouted joints.
 5. To remove the loosened epoxy residue and water, drag a clean sponge diagonally across the tile surface. Use one side of the sponge for each pass over the tile, rinsing the sponge following the second pass and regularly changing water in the buckets to avoid residue buildup.
 6. Do not allow excess water to remain on the tile surface, which would allow a film to form on the surface that would be difficult to remove once hardened.
 7. Within 15 to 20 minutes perform a final wash. To aid in the cleaning process, 30 ml (1 U.S. ounce) of clear dishwashing soap may be added to a 11.4 L (3 U.S. gallon) pail of clean water. Next, use a clean nonwoven nylon white scouring pad to loosen any remaining residue left on the tile from the first wash. Then follow the same cleaning process.
- F. MAPEI Flexcolor CQ and 3D:
1. Grout small areas of between 2.79 to 3.72 square metres (30 to 40 square feet) at a time, so that cleaning can begin before the grout skins over and dries on the tile surface.
 2. To aid in spreading MAPEI Flexcolor CQ and 3D, slightly moisten the tile surface with a damp, rounded grout sponge just before application.
 3. Force MAPEI Flexcolor CQ and 3D into the joints with a medium- to hard-rubber grout float held at a 45-degree angle to the tile surface. Make sure all joints are well-compacted and free of voids and gaps.
 4. Remove excess grout from the tile surface, holding the grout float at an almost 90-degree angle to the surface and moving the grout float diagonally to the joints while the grout is still fresh.
 5. The grout surface should be flush with the tile edge.
 6. Cleaning should begin after the surface develops a dry, skinned-over appearance, within 5 to 10 minutes, depending upon the temperature, humidity and absorption rate of the tile.
 7. Use two buckets of cleaning water: one for rinsing the majority of the grout residue from the grout sponge, and one for moistening the sponge in clean water.
 8. Move a moderately damp, rounded grout sponge across the tile surface in a circular motion to loosen grout and to shape the joints. Drag a clean and moderately damp sponge diagonally across the tile joints, applying slight pressure. Use one side of the sponge for each pass over the tile, rinsing the sponge after the second pass.
 9. Under certain conditions, a milky film can appear on the grout surface. This film will dissipate in 20 to 30 minutes after the washing step is completed.
 10. Change the water bucket frequently to prevent the development of a haze on the tile surface.
 11. If a residue is observed on the tile surface, a final wash can be performed about one hour after the initial wash. Add 30 mL (1 U.S. oz.) of a clear dishwashing soap to a pail

**Okaloosa County TDC – Emerald Coast Convention Center
Restroom Renovations and Meeting Room Counters**

containing 11.4 L (3 U.S. gallons) of clean water. Then use a clean, white, moistened scrub pad and a moistened sponge to remove the residue.

12. If the joints are not fully flush, MAPEI Flexcolor CQ and 3D can be re-applied after 24 hours of drying. If accent tile is used, verify tile thicknesses and retain first paragraph below if necessary. If difference in thickness is significant, consider providing a thicker substrate under thinner tile.

3.4 PROTECTION

- A. Protect installed tile work from damages by other trades and general abuse until substantial work completion and acceptance.
- B. Refer to manufacturer's product data sheet for recommendations regarding protection.

END OF SECTION 093123

**Okaloosa County TDC – Emerald Coast Convention Center
Restroom Renovations and Meeting Room Counters**

SECTION 099123 - INTERIOR PAINTING

PART 1 - GENERAL

1.1 SUMMARY

- A. This Section includes surface preparation and the application of paint systems on the following interior substrates:
1. Concrete masonry units (CMU).
 2. Steel.
 3. Galvanized metal.
 4. Gypsum board.

1.2 SUBMITTALS

- A. Product Data: For each type of product indicated.
- B. Samples: For each finish and for each color and texture required.
1. Submit samples on rigid backing, 8-inches (200 mm) square.
 2. Step coats on samples to show each coat required for system.
 3. Label each coat of each sample.
 4. Label each sample for location and application area.
- C. Product List: Printout of current "MPI Approved Products List" for each product category specified in Part 2, with the proposed product highlighted.

1.3 QUALITY ASSURANCE

- A. Applicator Qualifications: A firm or individual experienced in applying paints and coatings similar in material, design and extent to those indicated for this Project, whose work has resulted in applications with a record of successful in-service performance.
- B. Source Limitations: Obtain block filler and primers for each coating system from the same manufacturer as the finish coats.
- C. MPI Standards:
1. Products: Complying with MPI standards indicated and listed in "MPI Approved Products List."
 2. Preparation and Workmanship: Comply with requirements in "MPI Architectural Painting Specification Manual" for products and paint systems indicated.
- D. Mockups: Apply benchmark samples of each paint system indicated and each color and finish selected to verify preliminary selections made under sample submittals and to demonstrate aesthetic effects and set quality standards for materials and execution.
1. Architect will select one surface to represent surfaces and conditions for application of each paint system specified in Part 3.
 - a. Wall and Ceiling Surfaces: Provide samples of at least 100 sq. ft. (9 sq. m).
 - b. Other Items: Architect will designate items or areas required.
 2. Apply benchmark samples after permanent lighting and other environmental services have been activated.
 3. Final approval of color selections will be based on benchmark samples.
 - a. If preliminary color selections are not approved, apply additional benchmark samples of additional colors selected by Architect at no added cost to Owner.

**Okaloosa County TDC – Emerald Coast Convention Center
Restroom Renovations and Meeting Room Counters**

1.4 EXTRA MATERIALS

- A. Furnish extra materials described below that are from same production run (batch mix) as materials applied and that are packaged for storage and identified with labels describing contents.
 - 1. Quantity: Furnish an additional 5 percent, but not less than 1 gal. (3.8 L) of each material and color applied.

PART 2 - PRODUCTS

2.1 PAINT, GENERAL

- A. Material Compatibility:
 - 1. Provide materials for use within each paint system that are compatible with one another and substrates indicated, under conditions of service and application as demonstrated by manufacturer, based on testing and field experience.
 - 2. For each coat in a paint system, provide products recommended in writing by manufacturers of topcoat for use in paint system and on substrate indicated.
- B. Colors: As selected by Architect from manufacturer's full range.

2.2 BLOCK FILLERS

- A. Interior/Exterior Latex Block Filler: MPI #4.
 - 1. Epoxy Block Filler: MPI #116.

2.3 PRIMERS/SEALERS

- A. Interior Latex Primer/Sealer: MPI #50.

2.4 METAL PRIMERS

- A. Quick-Drying Alkyd Metal Primer: MPI #76.
- B. Waterborne Galvanized-Metal Primer: MPI #134.

2.5 LATEX PAINTS

- A. Interior Latex (Flat): MPI #53 (Gloss Level 1).
- B. Interior Latex (Satin): MPI #43 (Gloss Level 4).
- C. Interior Latex (Semigloss): MPI #54 (Gloss Level 5).

2.6 SOLVENT-BASED PAINTS

- A. Quick Dry (semigloss) MPI #81 (Gloss Level 5)

2.7 EPOXY PAINTS

- A. Epoxy cold cured gloss: MPI #77 (gloss level 5).

**Okaloosa County TDC – Emerald Coast Convention Center
Restroom Renovations and Meeting Room Counters**

2.8 FLOOR COATINGS

- A. Interior/Exterior Clear Concrete Floor Sealer (Water Based): MPI #99.
- B. Tile Clad High Solids with double cast grit (MPI#98)

PART 3 - EXECUTION

3.1 EXAMINATION

- A. Examine substrates and conditions, with Applicator present, for compliance with requirements for maximum moisture content and other conditions affecting performance of work.
- B. Maximum Moisture Content of Substrates: When measured with an electronic moisture meter as follows:
 - 1. Concrete: 12 percent.
 - 2. Masonry (Clay and CMU): 12 percent.
 - 3. Gypsum Board: 12 percent.
- C. Verify suitability of substrates, including surface conditions and compatibility with existing finishes and primers.
- D. Begin coating application only after unsatisfactory conditions have been corrected and surfaces are dry.
 - 1. Beginning coating application constitutes Contractor's acceptance of substrates and conditions.

3.2 PREPARATION AND APPLICATION

- A. Comply with manufacturer's written instructions and recommendations in "MPI Architectural Painting Specification Manual" applicable to substrates indicated.
- B. Remove plates, machined surfaces, and similar items already in place that are not to be painted. If removal is impractical or impossible because of size or weight of item, provide surface-applied protection before surface preparation and painting.
 - 1. After completing painting operations, use workers skilled in the trades involved to reinstall items that were removed. Remove surface-applied protection if any.
 - 2. Do not paint over labels of independent testing agencies or equipment name, identification, performance rating, or nomenclature plates.
- C. Concrete Substrates: Remove release agents, curing compounds, efflorescence and chalk. Do not paint surfaces if moisture content or alkalinity of surfaces to be painted exceeds that permitted in manufacturer's written instructions.
 - 1. Clean concrete floors to be painted with a 5 percent solution of muriatic acid or other etching cleaner. Flush the floor with clean water to remove acid, neutralize with ammonia, rinse, allow to dry and vacuum before painting.
- D. Concrete Masonry Substrates: Remove efflorescence and chalk. Do not paint surfaces if moisture content or alkalinity of surfaces to be painted exceeds that permitted in manufacturer's written instructions.
- E. Steel Substrates: Remove rust and loose mill scale. Clean using methods recommended in writing by paint manufacturer.

**Okaloosa County TDC – Emerald Coast Convention Center
Restroom Renovations and Meeting Room Counters**

1. Treat bare and sandblasted or pickled clean metal with a metal treatment wash coat before priming.
 2. Touch up bare areas and shop-applied prime coats that have been damaged. Wire brush, clean with solvents recommended by paint manufacturer, and tough up with same primer as the shop coat.
- F. Galvanized-Metal Substrates: Remove grease and oil residue from galvanized sheet metal fabricated from coil stock by mechanical methods to produce clean, lightly etched surfaces that promise adhesion of subsequently applied paints.
- G. Aluminum Substrates: Remove surface oxidation.
- H. Gypsum Board Substrates: Do not begin paint application until finishing compound is dry and sanded smooth.
- I. Clean substrates of substances that could impair bond of paints, including dirt, oil, grease, and incompatible paints and encapsulants.
1. Remove incompatible primers and reprime substrate with compatible primers as required to produce paint systems indicated.
- J. Apply paints according to manufacturer's written instructions.
1. Use applicators and techniques suited for paint and substrate indicated.
 2. Paint surfaces behind movable equipment and furniture same as similar exposed surfaces. Before final installation, paint surfaces behind permanently fixed equipment or furniture with prime coat only.
 3. Paint front and backsides of access panels, removable or hinged covers, and similar hinged items to match exposed surfaces.
 4. Do not paint over dirt, rust, scale, grease, moisture, scuffed surfaces, or conditions detrimental to formation of durable paint film.
 5. Provide finish coats that are compatible with primers used.
 6. The term "exposed surfaces" includes areas visible when permanent or built-in-fixtures, grilles, convector covers, covers for finned-tube radiation, and similar components are in place. Extend coatings in these areas, as required, to maintain system integrity and provide desired protection.
 7. Paint interior surfaces of ducts with a flat, nonspecular black paint where visible through registers or grilles.
 8. Finish interior of wall and base cabinets and similar field-finished casework to match exterior.
 9. Sand lightly between each succeeding enamel or varnish coat.
- K. Apply paints to produce surface films without cloudiness, spotting, holidays, laps, brush marks, roller tracking, runs, sags, ropiness, or other surface imperfections. Cut in sharp lines and color breaks.
- L. Painting Steel, Mechanical and Electrical Work: Paint items exposed, but not limited to the following:
1. Steel Work:
 - a. Exposed beams, columns, purlins, girts.
 - b. Exposed metal decking
 - c. Handrails, Guardrails, Risers, Stringers not scheduled to be galvanized.
 - d. Exposed miscellaneous fasteners, plates, angles
 - e. Other elements exposed to finished interior areas.
 2. Mechanical Work:
 - a. Uninsulated metal piping.
 - b. Uninsulated plastic piping.

**Okaloosa County TDC – Emerald Coast Convention Center
Restroom Renovations and Meeting Room Counters**

- c. Pipe hangers and supports.
- d. Tanks that do not have factory-applied final finishes.
- e. Visible portions of internal surfaces of metal ducts, without liner, behind air inlets and outlets.
- f. Duct, equipment, and pipe insulation having cotton or canvas insulation covering or other paintable jacket material.
- g. Mechanical equipment that is indicated to have a factory-primed finish for field painting.
- h. Fire Sprinkler piping and components.
- 3. Electrical Work:
 - a. Switchgear.
 - b. Panelboards.
 - c. Electrical equipment that is indicated to have a factory-primed finish for field painting.
 - d. Exposed conduit and boxes
- M. Protect work of other trades against damage from paint application. Correct damage to work of other trades by cleaning, repairing, replacing, and refinishing, as approved by Architect, and leave in an undamaged condition.
- N. Provide “Wet Paint” signs to protect newly painted finishes. After completing painting operations, remove temporary protective wrappings provided by others to protect their work.
- O. At completion of construction activities of other trades, touch up and restore damaged or defaced painted surfaces.

3.3 INTERIOR PAINTING SCHEDULE

- A. CMU Substrates:
 - 1. Latex System: MPI INT 4.2A.
 - a. Prime Coat: Interior/exterior latex block filler.
 - b. Intermediate Coat: Interior latex matching topcoat.
 - c. Topcoat: Interior latex (satin).
 - 2. Epoxy System: MPI INT 4.2G.
 - a. Prime Coat: Epoxy block filler.
 - b. Intermediate Coat: Epoxy cold cured gloss matching topcoat.
 - c. Topcoat: Epoxy cold cured (gloss).
- B. Steel Substrates:
 - 1. Alkyd Gloss Finish: MPI INT 5.1E.
 - a. Prime Coat: Quick-drying alkyd metal primer.
 - b. Intermediate Coat: Alkyd matching topcoat.
 - c. Topcoat: Alkyd (semigloss).
- C. Galvanized-Metal Substrates:
 - 1. Alkyd System: MPI INT 5.3L.
 - a. Prime Coat: Waterborne galvanized-metal primer.
 - b. Intermediate Coat: Alkyd matching topcoat.
 - c. Topcoat: Alkyd (semigloss).
- D. Gypsum Board Substrates:
 - 1. Latex System: MPI INT 9.2A.
 - a. Prime Coat: Interior latex primer/sealer.

**Okaloosa County TDC – Emerald Coast Convention Center
Restroom Renovations and Meeting Room Counters**

- b. Intermediate Coat: Interior latex matching topcoat.
- c. Topcoat: Interior latex (flat) at ceiling applications and (Satin) at wall applications.
- 2. Epoxy System: MPI INT 9.2F.
 - a. Prime Coat: Interior latex primer/sealer.
 - b. Intermediate Coat: Epoxy cold cured gloss matching topcoat.
 - c. Topcoat: Epoxy cold cured gloss.
- E. Interior Concrete Substrates:
 - 1. Epoxy System: MPI 98.
 - a. Tile-Clad High Solids epoxy polyamide coating.

END OF SECTION 099123

**Okaloosa County TDC – Emerald Coast Convention Center
Restroom Renovations and Meeting Room Counters**

SECTION 102113.40 - STONE TOILET COMPARTMENTS

PART 1 - GENERAL

1.1 SUMMARY

- A. Section includes: StonePly toilet compartments, urinal screens, privacy screens including required fittings, hardware, and accessories.
- B. Furnish and install supplementary blocking and accessories as shown in drawings for a complete and secure installation.

1.2 REFERENCES

- A. Americans with Disabilities (ADA) Standards for Accessible Design.
- B. ANSI A117.1 - American National Standard for Buildings and Facilities - Providing Accessibility and Usability for Physically Handicapped People.
- C. ASTM E84 - Surface Burning Characteristics of Building Materials.
- D. UFAS - Uniform Federal Accessibility Standards.
- E. ASTM C 119-04: Terminology Relating to Dimension Stone

1.3 SUBMITTALS

- A. Product Data: Submit product data, specifications and manufacturer's installation instructions.
- B. Shop Drawings: Submit shop drawings for Architect's review and approval prior to fabrication, including pertinent details for installation, showing layout plan, sizes, attachments, supports and adaptation of system to specific project.
- C. Samples: Submit a minimum of one 6" by 6" sample for each stone type selected.
- D. Test Data: Submit a summary of testing conducted verifying partition panel performance characteristics.

1.4 QUALITY ASSURANCE

- A. Source: Provide StonePly partitions which are the products of one manufacturer.

1.5 FIELD MEASUREMENTS

- A. Installer shall verify that field measurements are as indicated on shop drawings. Advise of any changes before fabrication and indicate measurements on Shop Drawings.
- B. Coordination: Coordinate location and quantity of any concealed in wall blocking.

1.6 DELIVERY, STORAGE AND HANDLING

**Okaloosa County TDC – Emerald Coast Convention Center
Restroom Renovations and Meeting Room Counters**

- A. Deliver materials and products in unopened factory labeled packages.=
- B. Store products in manufacturer's unopened packaging until ready for installation, in a clean dry area protected from weather, moisture and damage; store units upright and not stacked unless permitted by manufacturer.

PART 2 - PRODUCTS

2.1 ACCEPTABLE MANUFACTURER

- A. Acceptable Manufacturer: StonePly Co., 4400 Oneal St, Greenville, TX 75401 Tel: (903) 454-0904. Fax: (903)454-3642. Email: sales@stoneply.com www.Stoneply.com
- B. Substitutions: Not permitted.

2.2 MATERIALS AND PRODUCTS

- A. Varieties and Source:
 - 1. Stone: [Silestone Classic Calacatta Engineered Quartz] by StonePly Co.
- B. The stone shall match the sample
 - 1. Stone Finish shall be polished, [to match the approved sample]. Polished finish is standard.
- C. All reinforced stone partition panels and doors shall have the following properties.
 - 1. Thickness 1¼" to match standard of design
 - 2. Facing: ¼" thickness of engineered quartz as selected
 - 3. All exposed edges of panel shall be engineered quartz
 - 4. Reinforcing: ¾" aluminum honeycomb composite bonded with high strength epoxy
 - 5. Average Weight: 4.5 lbs. per sq. ft.
 - 6. Dimensional Tolerance: Plus or minus 1/8" (3.2mm) in all directions. Plus or minus 1/8" (3.2mm) diagonally.

2.3 PERFORMANCE REQUIREMENTS

- A. The stone panel's performance shall meet or exceed the following properties.
- B. Acid-Freeze-Thaw: Loss in flexural strength shall not exceed 20% after 100 freeze thaw cycles + 170F to -10F immersed in dilute sulfuric acid.
- C. Large Missile Impact test: Missile impact panel with a solid wood stud, nominal 2 x 4, #2 surface dry, Southern Pine of not less than 8'-6'. in length and 9 lbs. in weight at a velocity between 50 and 52 ft./sec. without defined specimen failure.
- D. Tension Bond Capacity: Shall exceed the tensile strength of the stone selected or 320 psi following accelerated aging by rapid freeze thaw temperature cycling from -20 degrees F to +130 degrees F.
- E. Flame Spread ASTM E-84 : 0 Maximum smoke development: 5. Maximum fuel contribution: 0

**Okaloosa County TDC – Emerald Coast Convention Center
Restroom Renovations and Meeting Room Counters**

2.4 ACCESSORIES

- A. Brackets: Stirrup Type: U-brackets,
 - 1. Stainless steel
- B. Hardware and Accessories: Manufacturer's standard design hardware and accessories.
 - 1. Stainless steel
- C. Fasteners: Manufacturer's exposed fasteners of stainless steel finished to match hardware.
 - 1. Provide theft-resistant-type heads.
 - 2. Provide through-bolt applications.

2.5 DOORS:

- A. Provide 24-inch- wide in-swinging StonePly doors for standard toilet compartments
- B. Provide 36-inch- wide out-swinging StonePly doors with a minimum 32-inch- wide clear opening for toilet compartments indicated to be ADA accessible.
- C. Hardware:
 - 1. Hinges: Self-closing type, adjustable to hold doors open at angle up to 90 degrees.
 - 2. Latch and Keeper: Latch unit designed for emergency access with door strike and keeper.
 - 3. Coat Hook: Combination hook and rubber-tipped bumper, sized to prevent door from hitting compartment-mounted accessories.
 - 4. Door Bumper: Rubber-tipped bumper at out-swinging doors.
 - 5. Door Pull: Door pulls complying with accessibility requirements at out-swinging doors. Provide units on both sides of doors at accessible compartments.

PART 3 – EXECUTION

3.1 PREPARATION

- A. Verify that site conditions are ready to receive work and opening dimensions are as indicated on shop drawings.
- B. Verify correct spacing of plumbing fixtures.

3.2 INSTALLATION

- A. Install in accordance with applicable code and manufacturer's recommendations, secure, plumb and true to line.
- B. Attach panels and pilasters to brackets with tamper-resistant thru-bolted screws.
- C. All panels shall be installed in proper alignment in accordance with the approved Shop Drawings.

3.3 ADJUSTMENT

- A. Adjust doors to work smoothly and correctly.
- B. Adjust and align hardware to uniform clearance at vertical edge of doors.

**Okaloosa County TDC – Emerald Coast Convention Center
Restroom Renovations and Meeting Room Counters**

- C. Adjust hinges to locate in swing doors in partial open position and out swing doors in closed position when unlatched.

3.4 CLEANING

- A. Clean all dirt and marks from stone partition panels using water or a stone cleaner appropriate for the type of stone and per manufacturer's recommendations.

END OF SECTION

**Okaloosa County TDC – Emerald Coast Convention Center
Restroom Renovations and Meeting Room Counters**

SECTION 102519 – MODULAR INTEGRATED LAVATORY SYSTEM

PART 1 - GENERAL

1.1 SUMMARY

A. Section Includes:

1. Integrated sink system with deck-mounted hand wash station accessories.

1.2 RELATED SECTIONS

- A. Division 22 Section "Domestic Water Piping Specialties" for thermostatic mixing valves.

1.3 REFERENCES

A. American Society of Sanitary Engineering (ASSE):

1. ASSE 1070 – Water Temperature Limiting Devices..

B. American National Standards Institute (ANSI):

1. ANSI Z 124.3 - Plastic Lavatories.
2. ANSI/ICPA SS-1-2001 - Performance Standard for Solid Surface Materials.

C. American Society of Mechanical Engineers (ASME):

1. ASME A112.18.1 - Plumbing Fixture Fittings.
2. ASME A112.18.2 - Plumbing Fixture Waste Fittings.
3. ASME A112.18.3 M - Performance Requirements for Backflow Protection Devices and Systems in Plumbing Fixture Fittings.

D. ASTM International (ASTM):

1. ASTM E 84 - Standard Test Method for Surface Burning Characteristics of Building Materials.

E. International Code Council (ICC)

1. ICC/ANSI A117.1 – Accessible and Usable Buildings and Facilities.

F. NSF International (NSF):

1. NSF 61 - Drinking Water System Components - Health Effects.

- G. Public Law 102-486, Energy Policy Act, requires that public lavatories manufactured after December 31, 1996, have flow rate or consumption not greater than 0.5 gpm (1.5 L/min.) or 0.25 gal. (0.95 L) per metering cycle.

H. Underwriters Laboratories, Inc.

1. UL 499 – Standard for Electric Heating Appliances
2. UL 723 - Test for Surface Burning Characteristics of Building Materials.

**Okaloosa County TDC – Emerald Coast Convention Center
Restroom Renovations and Meeting Room Counters**

3. UL 1951 - Electric Plumbing Accessories.

I. US Federal Government:

1. Public Law 102-486 - Energy Policy Act. 1992.
2. U.S. Architectural & Transportation Barriers Compliance Board. Americans with Disabilities Act (ADA), Accessibility Guidelines for Buildings and Facilities (ADAAG).

1.4 ACTION SUBMITTALS

- A. Product Data: Manufacturer's data sheets for lavatory unit and components.
- B. Installation Drawings: Include unit installation instructions, seam location and treatment if any, requirements for concealed blocking, plumbing and electrical rough-in and connection requirements, and wiring diagrams.

1.5 INFORMATION SUBMITTALS

- A. Manufacturer's Certificates: Indicate compliance with specification requirements.

1.6 MAINTENANCE SUBMITTALS

- A. Operation and maintenance data.

1.7 QUALITY ASSURANCE

- A. Manufacturer Qualifications: Approved manufacturer listed in this section. Manufacturers seeking approval must submit the following:
 1. Product data, including test data from qualified independent testing agency indicating compliance with requirements.
 2. Samples of each component of product specified.
 3. List of successful installations of similar products available for evaluation by Architect.
 4. Submit substitution request in compliance with Division 00 and Division 01 requirements.
- B. Source Limitations: Obtain each type of plumbing fixture and compatible accessories through one source from a single approved manufacturer.
- C. Accessibility Requirements: Comply with requirements of ADA/ABA and with requirements of authorities having jurisdiction.
- D. Water Flow and Consumption Requirements: Comply with Public Law 102-486 "Energy Policy Act."
- E. Drinking Water Standard: Comply with NSF 61, "Drinking Water System Components – Health Effects," where applicable.

**Okaloosa County TDC – Emerald Coast Convention Center
Restroom Renovations and Meeting Room Counters**

- F. Electrical Components: Listed and labeled per NFPA 70, Article 100, by a testing agency acceptable to authorities having jurisdiction.

PART 2 - PRODUCTS

2.1 MANUFACTURERS

- A. Basis-of-Design Product: Subject to compliance with requirements of this Section, provide D|13 Group, D|13 Sink System Model D|13 ISS-XL, 245 West Central Street, Natick MA 01760; 888-670-3107; pmarquez@d13group.com; www.d13group.com.

2.2 INTEGRATED SINK (LAVATORY) SYSTEM

- A. Integrated Sink System Unit (ISS): Deck with integral rectangular bowl, with under-deck enclosure panels, low-flow faucet, [soap dispenser,] and hand dryer, with stainless steel support system.
1. Basis of Design Manufacturer/Model: D|13 Group, D|13 Sink System Model D13- ISS-XL
 2. Configuration: Two Single units and One Three unit wash station unit.
 - a. Size: 24 by 30 inch ea.
 - b. Size: 24 by 90 inch ea.
 3. Mounting: Wall-mounted
 - a. Mounting Height to Sink Rim: [34 inch (863 mm)] unless otherwise indicated on Drawings.
 4. Deck Material: Silestone Quartz agglomerate material
 - a. Color: As selected by Architect [color Stellar Snow 13]
 5. Bowl: Solid surface material Corian under-mounted, 25 by 15 inches (635 by 381 mm).
 - a. Color: As selected by Architect [color Glacier White] .
 6. Enclosure: Solid Surface material Corian, sliding access panels.
 - a. Color and Pattern: [glacier white]
- B. Accessories
1. Hand Dryer: High-speed drying system integrated into lavatory deck with above-deck air spout that reverses air flow toward the back of the basin and concealed dryer. Equip with infrared optical sensor, adjustable speed/sound level and heating temperature controls, and HEPA filtration system with removable and washable metal mesh pre-filter.
 - a. Basis of Design Manufacturer/Model: Excel, XLERATOR.
 - b. Dry Time and Energy Use: 10-15 seconds.
 - c. Air Delivery Spout Material and Finish: Die-cast, polished chrome finish
 - d. Power Supply: Voltage: 110 VAC, 1500 W, 12.5 A. Equip unit with power chord for use with NEMA 5-20 receptacle on 20 A dedicated circuit, located as indicated on shop drawings.
 2. Faucet: Deck-mounted single-hole vandal-resistant handwashing faucet with battery backup, double-infrared sensor activated, with all serviceable components above deck.
 - a. Basis of Design Manufacturer/Model: [Sloan, EFX200 Series] [Insert faucet model].

**Okaloosa County TDC – Emerald Coast Convention Center
Restroom Renovations and Meeting Room Counters**

- b. Flow Rate: Not greater than 0.50 gpm (0.032 L/s).
- c. Material and Finish: [Die-cast, polished chrome finish] [Insert finish].
- d. Water Supply: Tempered supply.
 - 1) Solenoid Valve: 6.75 VDC, 50/60 Hz, electronically-activated, in removable carrier.
 - 2) Mixer Lever: Removable mechanical lever for manual pre-setting of temperature.
 - 3) Mixing Valve: Thermostatic mixing valve, ASSE 1070 listed, with stop/strainer/check valves, and flexible stainless steel connectors.
- e. Activation Controls: Low-voltage self-adjusting sensor using infrared transmitting beam and adjustable timed turn-off delay.
 - 1) Power Pack: Class II, UL, CSA-listed plug-in transformer.
- 3. Soap Dispenser: Below-deck-mounted unit with battery-powered sensor-operated valve, integrated into lavatory basin, with integral check valve.
 - a. Basis of Design Manufacturer/Model: liquid soap 5 liter dispenser Material and Finish: Die-cast, polished chrome finish
 - b. Refillable 5 liter Soap dispenser: provide two per unit.

2.3 LAVATORY DECK MATERIALS

- A. Quartz Agglomerate: Solid sheets consisting of quartz aggregates bound together with a matrix of filled plastic resin and complying with performance requirements of ANSI/ICPA-SS-1-2001.
 - 1. Products: Provide one of the following:
 - a. Cosentino USA, Silestone.
 - 2. Integral Sink Bowls: Solid surface material complying with CSA B45.5/IAPMO Z124, with tethered stainless-steel strainers and integral tailpieces.

2.4 ENCLOSURE MATERIAL

- A. Solid Surface Material: Homogeneous-filled plastic resin complying with ICPA SS-1.
 - 1. Products: Provide one of the following:
 - a. E. I. du Pont de Nemours and Company; Corian.
 - 2. Integral Sink Bowls: Solid surface material complying with CSA B45.5/IAPMO Z124, with optional tethered stainless-steel strainers and integral tailpieces.
 - 3. Integral Sink Bowls: Solid surface material complying with CSA B45.5/IAPMO Z124, with tethered stainless-steel strainers and integral tailpieces.
 - 4. Match Architect's samples for color, finish, and other stone characteristics relating to aesthetic effects.
 - 5. Integral Sink Bowls: Solid surface material complying with CSA B45.5/IAPMO Z124, with tethered stainless-steel strainers and integral tailpieces.
- B. Phenolic Composite: Solid, high-pressure decorative laminate fused to substrate during panel manufacture, complying with NEMA LD 3, Grade CGS.
 - 1. Products: Provide one of the following:
 - a. Formica Corporation; Compact Structural Laminates.
 - b. Wilsonart; Compact Laminate.

**Okaloosa County TDC – Emerald Coast Convention Center
Restroom Renovations and Meeting Room Counters**

2.5 ACCESSORY MATERIALS

- A. Composite Wood Products: Formaldehyde-free.
 - 1. Medium-Density Fiberboard (MDF): ANSI A208.2, Grade 130.
 - 2. Softwood Plywood: DOC PS 1, exterior.
- B. Stainless Steel Brackets: AISI Type 304, cold-formed.
- C. Removable Access Panel Fasteners: Integrated Z-clips.
- D. Fabrication Adhesive: Product recommended by material manufacturer.
 - 1. Adhesives shall have a VOC content of 70 g/L or less.
 - 2. Adhesive shall comply with the testing and product requirements of the California Department of Public Health's "Standard Method for the Testing and Evaluation of Volatile Organic Chemical Emissions from Indoor Sources Using Environmental Chambers."
- E. Installation Sealant for Unit-to-Wall Joints: Silicone, mildew-resistant, single-component, nonsag, plus 25 percent and minus 25 percent movement capability, nontraffic-use, acid-curing silicone joint sealant; ASTM C 920, Type S, Grade NS, Class 25, Use NT.

2.6 FABRICATION

- A. Deck Joints: Fabricate units in sections for joining in field, with joints at locations indicated on approved installation drawings.

PART 3 - EXECUTION

3.1 INSTALLATION

- A. Assemble fixtures and associated fittings and trim in accordance with manufacturer's instructions.
- B. Install unit supports firmly attached to building structure. Fasten units to wall by bolting through frame into blocking concealed in wall.
- C. Install fixtures level, plumb, and in accordance with manufacturer's rough-in instructions.
- D. Bond deck joints with adhesive and draw tight as units are set. Mask areas of deck adjacent to joints to prevent adhesive smears.
- E. Install splines in kerfs in deck edges at joints. Fill kerfs with adhesive before inserting splines and remove excess immediately after adjoining units are drawn into position.
- F. Clamp units to temporary bracing, supports, or each other to ensure that units are properly aligned.

**Okaloosa County TDC – Emerald Coast Convention Center
Restroom Renovations and Meeting Room Counters**

- G. Install water supply piping. Provide stop on each supply in readily-serviceable location. Fasten supply piping to supports or substrate.
- H. Install trap and waste piping to each fixture.
- I. Install escutcheons at exposed piping penetrations in finished locations and within cabinets.
- J. Seal joints between fixtures and walls, floors, and units with mildew-resistant silicone sealant.

3.2 CLEANING AND PROTECTION

- A. Repair or replace defective work, including damaged fixtures and components.
- B. Clean unit surfaces, test fixtures, and leave in ready-to-use condition.
- C. Install new batteries in battery-operated devices at time of Substantial Completion.
- D. Turn over keys, tools, maintenance instructions, and maintenance stock to Owner.
- E. Protect units with water-resistant temporary covering. Do not allow temporary use of plumbing fixtures. Remove protection at Substantial Completion and dispose.

3.3 TESTING AND ADJUSTING

- A. Set field-adjustable temperature set points of water mixing valves. Adjust set point within allowable temperature range.
- B. Test and adjust installation.

END OF SECTION 102519

**Okaloosa County TDC – Emerald Coast Convention Center
Restroom Renovations and Meeting Room Counters**

SECTION 260500 - ELECTRICAL GENERAL REQUIREMENTS**PART 1 - GENERAL****1.1 SUMMARY**

The Electrical General Requirements are supplementing and applicable to Division 26 Sections and shall apply to all phases of work specified herein, shown on the Drawings, or required to provide a complete installation of electrical systems. Section 26 is sub-divided for convenience only.

A. This Section includes the following:

1. Job Conditions
2. Regulatory Requirements
3. Electrical equipment coordination and installation.
4. Submittals, Operating and Maintenance instructions and As-built drawings.
5. Common electrical installation requirements.
6. Warranty of work.

1.2 JOB CONDITIONS:

- A. SITE INSPECTIONS:** Before submitting proposals, each bidder should visit the site and fully familiarize himself with all job conditions and shall be fully informed as to the extent of his work. No consideration will be given after bid opening date for alleged misunderstanding as to the requirements of work involved in connecting to the utilities or as to requirements of materials to be furnished. The contractor shall contact the utility prior to bid and make appropriate provisions in such bid as required by the utility for the utility's routing and connection.
- B. SCHEDULED INTERRUPTIONS:** Planned interruptions of utilities service, to any facility affected by this contract, shall be carefully planned and approved by Architect at least ten (10) days in advance of the requested interruption. The Contractor shall not interrupt services until the Architect has granted specific approval. The request shall indicate services to be affected, date and time of interruption and duration of outage. Request for interruption of service will not be approved until all equipment and materials required for the completion of that particular phase of work are on the job site. The work may have to be scheduled after normal working hours.
- C. ACCIDENTAL INTERRUPTIONS:** All excavation and/or remodeling work required shall be performed with care so as not to interrupt other existing services (water, gas, electrical, sewer, sprinklers, etc.). If accidental utility interruption resulting from work performed by the Contractor occurs, service shall be immediately restored to its original condition without delay, by and at the expense of the Contractor, using skilled workmen of the trade required.

**Okaloosa County TDC – Emerald Coast Convention Center
Restroom Renovations and Meeting Room Counters**

1.3 REGULATORY REQUIREMENTS:

- A. PERMITS, FEES, AND INSPECTIONS: This Contractor shall secure and pay for all permits, and inspections required on work performed under this section of the Specifications. He shall assume full responsibility for all assessments and taxes necessary for the completion and acceptance of the work.
- B. APPLICABLE STANDARDS AND CODES: The electrical installation shall comply with all applicable building codes; local, state, and federal ordinances; and the 2014 edition of the National Electrical Code. In case of a discrepancy among these applicable regulatory codes and ordinances, the most stringent requirement shall govern. The Contractor shall notify the Architect in writing of any such discrepancy. Should the Contractor perform any work that does not comply with the applicable regulatory codes and ordinances he shall bear all cost arising in correcting the deficiencies. Application standards and codes shall include all local ordinances, all state laws, and the applicable requirements of the following:
1. American National Standards Institute - ANSI
 2. National Electrical Manufacturer's Association - NEMA
 3. National Fire Protection Association – NFPA (latest editions)
 4. The Life Safety Code – NFPA 101, as adopted in Florida Edition
 5. The National Fire Alarm Code – NFPA 72, as adopted in Florida Edition
 6. Florida Building Code, latest Edition
 7. Underwriters' Laboratories, Inc. – UL
- C. DRAWINGS AND SPECIFICATIONS: The drawings and these specifications are complementary each to the other. What is called for by one shall be as binding as if called for by both. Omissions from the drawings and specifications of details of work which are evidently necessary to carry out the intent of the drawings and specifications, or which are customarily performed, shall not relieve the Contractor from performing such work. In any case of discrepancy in the figures or catalog numbers, the matter shall be submitted to the Architect, who shall promptly make a determination in writing. Any adjustment by the Contractor shall be at the Contractor's own risk and expense. Electrical drawings are diagrammatic only. Do not scale these drawings. All equipment shall be installed in accordance with manufacturer's recommendations and any conflicting data shall be verified before bidding.
- D. The Contractor shall after completion of the work, furnish the Architect a certificate of final inspection and approval from the applicable local inspection department. Make necessary changes to plans and specifications to meet code standards at no additional cost to the Owner.

1.4 COOPERATION:

- A. INTERFACING WITH OTHER CRAFTS: It shall be the responsibility of the Contractor to cooperate and coordinate with all other crafts working on this project. This Contractor shall do all cutting, trenching, backfill and structural removals to permit entry of the electrical system components. The General Contractor shall do all patching and finishing.

**Okaloosa County TDC – Emerald Coast Convention Center
Restroom Renovations and Meeting Room Counters**

- B. **EQUIPMENT FURNISHED UNDER OTHER SECTIONS:** This Contractor shall furnish and install, complete electrical roughing-in and connections to all equipment furnished under other sections and indicate on drawings. This includes all outlets as shown on mechanical, telecom, and electrical drawings. All such equipment shall be set in place as work of other sections.
- C. **HEATING AND AIR CONDITIONING:**
1. The Contractor shall furnish all branch circuit wiring to motors and control panels or centers including disconnects, receptacles, switches, and appurtenances to which the system at the units may be connected, to provide a complete system of wiring for power. Control equipment and control circuit wiring is specified in the Mechanical Section.
 2. Control devices to be included in the branch circuit, except those furnished integral with the equipment, will be delivered by the Heating and Air Conditioning Contractor and installed by the Electrical Contractor.
- 1.5 **WORKMANSHIP:** All work shall be executed in a neat and substantial manner by skilled workman, well qualified, and regularly engaged in the type of work required. Substandard work shall be removed and replaced by the Contractor at no cost to the Owner.
- 1.6 **APPROVAL OF MATERIALS AND EQUIPMENT:**
- A. **PRIOR-SUBMITTALS:** The Contractor shall base his proposal on the materials specified herein and on the drawings. Reference to a particular product by manufacturer, trade name, or catalog number establishes the quality standards of material and equipment required for this installation and is not intended to exclude products equal in quality and similar design. The Architect reserves the sole right to decide the equality of materials proposed for use in lieu of these specified. It shall be the Contractor's responsibility to furnish the information and data sufficient to establish the quality and utility of the items in question, including furnishing of samples if required.
- B. **SUBMITTALS:**
1. Submittals: The Contractor shall submit a list of equipment proposed for installation. He shall submit catalog data and shop drawings on all proposed systems and their components. Where substitutions alter the design or space requirements, the Contractor shall defray all items of cost for the revised design and construction including costs to all allied trades involved. Provide an electronic copy and (1) hard copy to the engineer of submittals and shop drawings as a minimum unless the General Conditions requires a greater number of copies.
 - a. **Submittals Schedule:** Submittals shall be submitted within thirty (30) days after the contract is awarded. It is not the responsibility of the Engineer to expedite the review of submittals if the contractor has not adequately prepared the submittals in a time efficient manner. The contractor bears all the responsibility for the added time requirements of resubmittals.

**Okaloosa County TDC – Emerald Coast Convention Center
Restroom Renovations and Meeting Room Counters**

- b. Identification: Place a permanent label or title block on each submittal for identification. Each major section of submittals such as power equipment, lighting equipment, fire alarm, etc., shall be secured in a booklet or stapled with a covering index which lists the following information:
 - 1) Project name and date
 - 2) Name, address, and phone number of General contractor and project manager.
 - 3) Name, address, and phone number of Sub-contractor and project manager.
 - 4) Supplier of equipment with phone number and person responsible for this project.
 - 5) Index of each item covered in submittal and model number.
 - 6) Any deviation from contract documents shall be specifically noted on submittal cover index and specifically identified with highlighting, encircling, or boldly on specific submittal sheet.

- c. Resubmittals: Make resubmittals in same form and number of copies as initial submittal.
 - 1) Include previous submittal review comments.
 - 2) For each item being resubmitted, include previous review comment and explain how resubmitted item meets the criteria of the previous review comment.

2. Electrical and Mechanical/Plumbing/Fire Protection Equipment Coordinations:

The electrical power equipment submittals shall be accompanied by a letter verifying coordination of electrical services for all mechanical, plumbing, and fire protection equipment requiring power. The letter shall follow the format listed below.

To: (General Contractor)

Re: (Project name and location)

We the undersigned subcontractors certify that we have coordinated the electrical requirements for mechanical, plumbing, and fire protection sprinkler equipment as evidenced by the coordination chart listed herein.

Item	Load Full Load Amps	1 Phase or 3 Phase	Number of Electrical Connections	Maximum Overcurrent Protection	Minimum Overcurrent Protection	Breaker Proposed	Circuit Proposed

**Okaloosa County TDC – Emerald Coast Convention Center
Restroom Renovations and Meeting Room Counters**

The above list details all required electrical connections for mechanical equipment.

Signed: _____

For: Mechanical Subcontractor

The above list details all required electrical connections for plumbing equipment.

Signed: _____

For: Plumbing Subcontractor

The above list details all required electrical and fire alarm connections for fire protection equipment.

Signed: _____

For: _____
Fire Protection Sprinkler Subcontractor

The above list of equipment has been reviewed and the required connections are being provided. (Any exceptions or request for direction shall be listed here)

Signed: _____

For: Electrical Subcontractor

1.7 PRODUCT DELIVERY, STORAGE AND HANDLING

- A. PROTECTION: Take necessary precautions to protect all material, equipment, apparatus and work from damage. Failure to do so to the satisfaction of the Architect will be sufficient cause for the rejection of the material, equipment or work in question. Contractor is responsible for the safety and good condition of the materials installed until final acceptance by the owner.
- B. CLEANING: Conduit openings shall be capped or plugged during installation. Fixtures and equipment shall be tightly covered and protected against dirt, moisture, chemical and mechanical injury. At the completion of the work the fixtures, material and equipment shall be thoroughly cleaned and delivered in condition satisfactory to the Architect.

**Okaloosa County TDC – Emerald Coast Convention Center
Restroom Renovations and Meeting Room Counters**

- 1.8 TESTING AND BALANCING: Make tests that may be required by the Owner or the Architect in connection with the operation of the electrical system in the buildings. Balance all single-phase loads connected to all panelboards in the buildings to insure approximate equal divisions of these loads on the main secondary power supply serving the buildings. All tests shall be made in accordance with the latest standards of the IEEE and the NEC. The installation shall be tested for performance, grounds and insulation resistance. A "megger" type instrument shall be used. Contractor shall perform circuit continuity and operational tests on all equipment furnished or connected by Contractor. The tests shall be made in the presence of the Architect or his representative. The Contractor shall notify the Architect at least twenty-four (24) hours in advance of tests. The Contractor shall provide all testing equipment and all costs shall be borne by him. Written reports shall be made of all tests. All faults shall be corrected immediately.
- A. A letter shall be written giving the following:
1. Measured amps on each phase of each panel.
 2. Resistance to ground of each new grounding electrode.
 3. Measured voltage phase to phase and phase to neutral at each panel.
 4. Ground continuity and polarity instrument used.
- 1.9 OPERATING AND MAINTENANCE INSTRUCTIONS/AS BUILT DRAWINGS:
- A. Four (4) complete sets of instructions containing the manufacturer's operating and maintenance instructions for each piece of equipment shall be furnished to the Owner. Each set shall be permanently bound and shall have a hard cover. One complete set shall be furnished at the time that the test procedure is submitted, and remaining sets shall be furnished before the Contract is completed. Flysheets shall be placed before instructions covering each subject. The instruction sheets shall be approximately 8-1/2" by 11" with large sheets of Drawings folded in. The instructions shall include information for major pieces of equipment and systems.
- B. Upon completion of the work and at the time designated, the services of one project engineer shall be provided by the Contractor to instruct the representative of the Owner in the operation and maintenance of the systems.
- C. This Contractor shall provide as-built Drawings at the completion of the job. Drawings shall show all significant changes in equipment, wiring, routing, location, etc. All underground conduit routing shall be accurately indicated with locations dimensioned. As-built drawings shall be submitted for review as red-lined on a field hard copy. After review by the Architect, the Contractor will be given digital AutoCAD files and shall make revisions and resubmit final on disk.
- 1.10 GUARANTEE AND SERVICE: Upon completion of all tests and acceptance, the Contractor shall furnish the Owner a written guarantee covering the electrical work done for a period of one (1) year from date of acceptance. Guarantee includes equipment capacity and performance ratings specified without excessive noise levels. Upon notice from the Architect or the Owner, the Contractor shall, during the guarantee period, rectify and replace any defective material or workmanship and repair any damage caused thereby without additional cost.

**Okaloosa County TDC – Emerald Coast Convention Center
Restroom Renovations and Meeting Room Counters**

PART 2 - PRODUCTS

PART 3 - EXECUTION

3.1 COMMON REQUIREMENTS FOR ELECTRICAL INSTALLATION

- A. Comply with NECA 1.
- B. Measure indicated mounting heights to bottom of unit for suspended items and to center of unit for wall-mounting items.
- C. Headroom Maintenance: If mounting heights or other location criteria are not indicated, arrange and install components and equipment to provide maximum possible headroom consistent with these requirements.
- D. Equipment: Install to facilitate service, maintenance, and repair or replacement of components of both electrical equipment and other nearby installations. Connect in such a way as to facilitate future disconnecting with minimum interference with other items in the vicinity.
- E. Right of Way: Give to raceways and piping systems installed at a required slope.

END OF SECTION 260500

**Okaloosa County TDC – Emerald Coast Convention Center
Restroom Renovations and Meeting Room Counters**

Page left blank

**Okaloosa County TDC – Emerald Coast Convention Center
Restroom Renovations and Meeting Room Counters**

SECTION 260510 – ELECTRICAL METHODS AND BASIC MATERIALS

PART 1 - GENERAL

1.1 SECTION INCLUDES:

- A. SUPPORTS
- B. EXCAVATION, TRENCHING, AND BACKFILLING
- C. CUTTING AND PATCHING
- D. EQUIPMENT CONNECTION
- E. IDENTIFICATION OF EQUIPMENT
- F. CLEANING AND PAINTING

PART 2 - PRODUCTS

2.1 SUPPORTS:

- A. FRAMING STEEL: Galvanized or painted rolled steel of standard shapes and sizes.
- B. MANUFACTURED CHANNEL: Hot dipped galvanized with all hardware required for mounting as manufactured by Unistrut, Steel City, or approved equal.
- C. MISCELLANEOUS HARDWARE: Standard sizes treated for corrosion resistance.

2.2 IDENTIFICATION:

- A. NAMEPLATES: Laminated black micarta with ¼” high engraved white letters.
- B. PANEL DIRECTORIES: Typewritten under plastic cover.
- C. WIRE AND CABLE MARKERS: Cloth, split sleeve, or tubing type.

PART 3 - EXECUTION

3.1 INSTALLATION

**Okaloosa County TDC – Emerald Coast Convention Center
Restroom Renovations and Meeting Room Counters**

- A. Products shall be installed in accordance with manufacturer's instructions.
- B. Install support systems sized and fastened to accommodate weight of equipment and conduit, including wiring, which they carry.
 - 1. Fasten hanger rods, conduit clamps, and outlet junction boxes to building structure using pre-cast insert system, expansion anchors, preset inserts, beam clamps, or spring steel clips.
 - 2. Use toggle bolts or hollow wall fasteners in hollow masonry, plaster, or gypsum board partitions and walls; expansion anchors or preset inserts in solid masonry walls; self-drilling anchors or expansion and anchors on concrete surfaces; sheet metal screws in sheet metal studs; and wood screws in wood construction.
 - 3. Do not fasten supports to piping, ceiling support wires, ductwork, mechanical equipment, or conduit.
 - 4. Do not use powder-actuated anchors.
 - 5. Do not drill structural steel members without written consent from the Architect.
 - 6. Fabricate supports from structural steel or steel channel.
 - 7. Install surface mounted cabinets and panel boards with minimum of four anchors.
 - 8. Provide steel channel supports to stand cabinets one inch off wall in wet locations.
 - 9. Bridge studs top and bottom with channels to support flush mounted cabinets and panel boards in stud walls.
- C. Excavating, trenching, and backfilling shall be accomplished as indicated on the Drawings or where required to install systems and/or equipment.
 - 1. Trenches for all underground conduits or equipment shall be excavated to the required depths. Where soft, wet, or unstable soil is encountered, the bottom of the trench shall be filled with 6 inches of compacted gravel and sand fill. All trench bottoms shall be tamped hard. Trenches shall be shored as required to meet OSHA requirements and general safe working conditions.
 - 2. After conduits or equipment have been inspected and approved by the Architect and prior to backfilling, all forms shall be removed and the excavation shall be cleaned of all trash and debris. Material for backfilling shall consist of the excavation, or borrow of sand, gravel, or other materials approved by the Architect and shall be free of trash, lumber or other debris. Backfill shall be placed in horizontal layers, not exceeding 9 inches in depth and properly moistened to approximate optimum requirements. Each layer shall be compacted by hand, or machine tamped to a density equivalent to surrounding soil. Backfill shall be brought to suitable elevation above ground to provide

**Okaloosa County TDC – Emerald Coast Convention Center
Restroom Renovations and Meeting Room Counters**

for anticipated settlement and shrinkage. All paving broken up shall be repaired and returned to the original condition.

3. All exterior underground conduits shall have an underground (metal foil) tape installed 12 inches above conduit identified as ELECTRICAL to aid in future location of conduit.
 4. All underground conduits shall have an underground red tape installed 12” above conduit.
- D. **CUTTING AND PATCHING:** This Contractor shall provide all cutting, digging, etc., incident to his work and shall make all required repairs thereafter to the satisfaction of the Architect, but in no case shall the Contractor cut into any major structural element, beam, or column without written approval of the Architect.
1. Pavements, sidewalks, roads, curbs, walls, ceilings, floors, and roofs shall be sawcut, patched, repaired and/or replaced as required to permit the installation of the electrical work. Existing concrete floors and other slabs, which require vertical piercing for installation of conduit raceways shall be neatly core drilled. The Contractor shall carefully lay out his drilling in advance and arrange it to minimize exposed work.
 2. The Contractor shall bear the expense of all cutting, patching, painting, repairing, or replacing of the work of other trades required because of his fault, error, or tardiness or because of any damage done by him.
 3. All patching, and finishing shall be performed by the General Contractor.
- E. Make electrical connections to equipment in accordance with equipment manufacturer’s instructions.
1. Verify that wiring and outlet rough-in work is complete and that equipment is ready for electrical connection, wiring, and energization.
 2. Make wiring connections in control panel or in wiring compartment of pre-wired equipment. Provide interconnecting wiring where indicated.
 3. Install and connect disconnect switches, controllers, control stations, and control devices as indicated.
 4. Make conduit connections to equipment using flexible conduit. Use liquid-tight flexible conduit in damp or wet locations.
 5. Install pre-fabricated cord set where connections with attachment plug is indicated or specified, or use attachment plug with suitable strain-relief clamps.
 6. Provide suitable strain-relief clamps for cord connections to outlet boxes and equipment connection boxes.

**Okaloosa County TDC – Emerald Coast Convention Center
Restroom Renovations and Meeting Room Counters**

- F. Identify electrical distribution and control equipment, and loads served, to meet regulatory requirements and as specified herein.
1. Degrease and clean surface to receive nameplates.
 2. Secure nameplates to equipment fronts using screws or rivets with edges parallel to equipment lines.
 3. Each new panel shall have an external nameplate. Disconnect switches, starters or similar devices shall have a micarta engraved nameplate mechanically affixed indicating the load served and the location, such as “A/C 2” or “A/C 3 above ceiling”. Letters shall be ¼” white on a black background. Panels shall be designated in this manner:

“Panel A
120/208 Volts
3 Phase 4 Wire
Served from Panel MP”
 4. Panel directories shall accurately indicate load served and location of load.
 5. Engrave plates as indicated on the Drawings.
- G. Raceway junction boxes for each system shall be identified by painting the inside of the junction box cover for exposed work and both sides of the covers for concealed work according to the following code:
- | | |
|--------------------------|-------|
| Receptacle Circuits | Black |
| 120 V. Lighting Circuits | White |
| 208 V. Power & Misc. | Green |
| Fire Alarm System | Red |
- If the established color code at this site conflicts with the above, the contractor shall so state in a letter outlining his proposed colors to maintain conformity
- H. Install wire markers on each conductor in panel board gutters, boxes, and at load connections.
1. Use distribution panel and branch circuit or feeder number to identify power and lighting circuits.
 2. Use control wire number as indicated on schematic and interconnection diagrams or equipment manufacturer’s shop drawings to identify control wiring.
- I. Cleaning and Painting: The respective Contractors for the various phases of work shall clear away all debris, surplus materials, etc., resulting from their work or operations, leaving the job and equipment furnished in the clean first class condition.

**Okaloosa County TDC – Emerald Coast Convention Center
Restroom Renovations and Meeting Room Counters**

1. All fixtures and equipment shall be thoroughly cleaned of plaster, stickers, rust, stains and other foreign matter or discoloration, leaving every part in an acceptable condition ready for use.
2. The Contractor shall refinish and restore to the original condition and appearance, all electrical equipment, which has sustained damage to manufacturer's prime and finish coats or enamel or paint. Materials and workmanship shall be equal to the requirements described for other painting.

END OF SECTION 260510

**Okaloosa County TDC – Emerald Coast Convention Center
Restroom Renovations and Meeting Room Counters**

Page left blank

**Okaloosa County TDC – Emerald Coast Convention Center
Restroom Renovations and Meeting Room Counters**

SECTION 260519 – LOW-VOLTAGE ELECTRICAL POWER CONDUCTORS AND CABLES (600 VOLTS OR LESS)

PART 1 - GENERAL

1.1 SUMMARY

- A. This Section includes building wires and cables and associated connectors, splices, and terminations for wiring systems rated 600 V and less.

1.2 SUBMITTALS

- A. Field quality-control test reports.

1.3 QUALITY ASSURANCE

- A. Electrical Components, Devices, and Accessories: Listed and labeled as defined in NFPA 70, Article 100, by a testing agency acceptable to authorities having jurisdiction, and marked for intended use.
- B. Comply with NFPA 70.

PART 2 - PRODUCTS

2.1 MANUFACTURERS

- A. In other Part 2 articles where subparagraph titles below introduce lists, the following requirements apply for product selection:

Available Manufacturers: Subject to compliance with requirements, manufacturers offering products that may be incorporated into the Work include, but are not limited to, the manufacturers specified.

2.2 CONDUCTORS AND CABLES

- A. Manufacturers:
 - 1. American Insulated Wire Corp.; a Leviton Company.
 - 2. General Cable Corporation.
 - 3. Senator Wire & Cable Company.
 - 4. Southwire Company.
 - 5. Okonite

**Okaloosa County TDC – Emerald Coast Convention Center
Restroom Renovations and Meeting Room Counters**

- B. Refer to Part 3 "Conductor and Insulation Applications" Article for insulation type, cable construction, and ratings.
- C. Conductor Material: Copper. Solid conductor for No. 10 AWG and smaller, stranded for No. 8 AWG and larger. Aluminum conductors using compact sector stranding will be permitted for circuits 100 amps and above. Contractor shall upsize conductor and conduits for aluminum equivalents and submit for approval.
- D. Conductor Insulation Types: THHN-THWN and SO.

2.3 CONNECTORS AND SPLICES

- A. Manufacturers: AFC Cable Systems, Inc.
 - 1. AMP Incorporated/Tyco International.
 - 2. Hubbell/Anderson.
 - 3. O-Z/Gedney; EGS Electrical Group LLC.
 - 4. 3M Company; Electrical Products Division.
- B. Description: Factory-fabricated connectors and splices of size, ampacity rating, material, type, and class for application and service indicated.
- C. Connections from boxes to lay-in fixtures in grid ceiling may be made with MC (metal clad) cable cut to minimum length.

PART 3 - EXECUTION

3.1 CONDUCTOR AND INSULATION APPLICATIONS

- A. Service Entrance: Type THHN-THWN, single conductors in raceway.
- B. Exposed Feeders: Type THHN-THWN, single conductors in raceway.
- C. Feeders Concealed in Ceilings, Walls, and Partitions: Type THHN-THWN, single conductors in raceway.
- D. Feeders Concealed in Concrete, below Slabs-on-Grade, and in Crawlspace: Type THHN-THWN, single conductors in raceway.
- E. Exposed Branch Circuits, including in Crawlspace: Type THHN-THWN, single conductors in raceway.
- F. Branch Circuits Concealed in Ceilings, Walls, and Partitions: Type THHN-THWN, single conductors in raceway.
- G. Branch Circuits Concealed in Concrete and below Slabs-on-Grade: Type THHN-THWN, single conductors in raceway.

**Okaloosa County TDC – Emerald Coast Convention Center
Restroom Renovations and Meeting Room Counters**

- H. Cord Drops and Portable Appliance Connections: Type SO, hard service cord.
- I. Fire Alarm Circuits: Type THHN-THWN, in raceway.
- J. Class 1 Control Circuits: Type THHN-THWN, in raceway.
- K. Class 2 Control Circuits: Power-limited cable, concealed in building finishes.

3.2 INSTALLATION

- A. Conceal cables in finished walls, ceilings, and floors, unless otherwise indicated.
- B. Use manufacturer-approved pulling compound or lubricant where necessary; compound used must not deteriorate conductor or insulation. Do not exceed manufacturer's recommended maximum pulling tensions and sidewall pressure values.
- C. Use pulling means, including fish tape, cable, rope, and basket-weave wire/cable grips, that will not damage cables or raceway.
- D. Install exposed cables parallel and perpendicular to surfaces of exposed structural members, and follow surface contours where possible.
- E. Support cables according to Division 26 Section "Raceways and Boxes for Electrical Systems."
- F. Seal around cables penetrating fire-rated elements according to Division 21 Section "Firestop Systems and Sleeves."
- G. Identify and color-code conductors and cables according to Division 26 Section "Identification for Electrical Systems."
- H. Make splices and taps that are compatible with conductor material and that possess equivalent or better mechanical strength and insulation ratings than unspliced conductors.
 - 1. Use oxide inhibitor in each splice and tap conductor for aluminum conductors.
- I. Wiring at Outlets: Install conductor at each outlet, with at least 6 inches (150 mm) of slack.

3.3 FIELD QUALITY CONTROL

- A. Testing: Perform each electrical test and visual and mechanical inspection stated in NETA ATS, Section 7.3.1. Certify compliance with test parameters.
- B. Test Reports: Prepare a written report to record the following:
 - 1. Test procedures used.
 - 2. Test results that comply with requirements.

**Okaloosa County TDC – Emerald Coast Convention Center
Restroom Renovations and Meeting Room Counters**

3. Test results that do not comply with requirements and corrective action taken to achieve compliance with requirements.

END OF SECTION 260519

**Okaloosa County TDC – Emerald Coast Convention Center
Restroom Renovations and Meeting Room Counters**

SECTION 260523 – FIRESTOP SYSTEMS AND SLEEVES

PART 1 - GENERAL

1.1 SUMMARY

- A. This Section includes the following:
 - 1. Through penetration firestop systems.
 - 2. Sleeves for raceways and cables.
 - 3. Sleeve seals.

1.2 PERFORMANCE REQUIREMENTS

- A. Rated Systems: Provide through-penetration firestop systems with the following ratings determined per UL 1479:
 - 1. F-Rated Systems: Provide through-penetration firestop systems with F-ratings indicated, but not less than that equaling or exceeding fire-resistance rating of constructions penetrated.
 - 2. T-Rated Systems: For the following conditions, provide through-penetration firestop systems with T-ratings indicated, as well as F-ratings, where systems protect penetrating items exposed to potential contact with adjacent materials in occupiable floor areas:
 - a. Penetrations located outside wall cavities.
 - b. Penetrations located outside fire-resistance-rated shaft enclosures.
 - 3. L-Rated Systems: Where through-penetration firestop systems are indicated in smoke barriers, provide through-penetration firestop systems with L-ratings of not more than 3.0 cfm/sq. ft (0.01524cu. m/s x sq. m) at both ambient temperatures and 400 deg F (204 deg C).
- B. For through-penetration firestop systems exposed to view, traffic, moisture, and physical damage, provide products that, after curing, do not deteriorate when exposed to these conditions both during and after construction.
- C. For through-penetration firestop systems exposed to view, provide products with flame-spread and smoke-developed indexes of less than 25 and 450, respectively, as determined per ASTM E 84.

1.3 QUALITY ASSURANCE

- A. Installer Qualifications: A firm that has been approved by FMG according to FMG 4991, "Approval of Firestop Contractors."

**Okaloosa County TDC – Emerald Coast Convention Center
Restroom Renovations and Meeting Room Counters**

- B. Installation Responsibility: Assign installation of through-penetration firestop systems and fire-resistive joint systems in Project to a single qualified installer.
- C. Fire-Test-Response Characteristics: Provide through-penetration firestop systems that comply with the following requirements and those specified in Part 1 "Performance Requirements" Article:
 - 1. Firestopping tests are performed by a qualified testing and inspecting agency. A qualified testing and inspecting agency is UL or another agency performing testing and follow-up inspection services for firestop systems acceptable to authorities having jurisdiction.
 - 2. Through-penetration firestop systems are identical to those tested per testing standard referenced in "Part 1 Performance Requirements" Article. Provide rated systems bearing classification marking of qualified testing and inspecting agency.
- D. Coordinate construction of openings and penetrating items to ensure that through-penetration firestop systems are installed according to specified requirements.
- E. Do not cover up through-penetration firestop system installations that will become concealed behind other construction until each installation has been examined by building inspector, if required by authorities having jurisdiction.

PART 2 - PRODUCTS

2.1 MANUFACTURERS

- A. Products: Subject to compliance with requirements, provide one of the through-penetration firestop systems indicated for each application that are produced by one of the following manufacturers:
 - 1. A/D Fire Protection Systems Inc.
 - 2. Hilti, Inc.
 - 3. Nelson Firestop Products.
 - 4. NUCO Inc.
 - 5. RectorSeal Corporation (The).
 - 6. Specified Technologies Inc.
 - 7. 3M; Fire Protection Products Division.
 - 8. Tremco; Sealant/Weatherproofing Division.

2.2 FIRESTOPPING

- A. Compatibility: Provide through-penetration firestop systems that are compatible with one another; with the substrates forming openings; and with the items, if any, penetrating through-penetration firestop systems, under conditions of service and application, as demonstrated by through-penetration firestop system manufacturer based on testing and field experience.

**Okaloosa County TDC – Emerald Coast Convention Center
Restroom Renovations and Meeting Room Counters**

- B. Accessories: Provide components for each through-penetration firestop system that are needed to install fill materials and to comply with Part 1 "Performance Requirements" Article. Use only components specified by through-penetration firestop system manufacturer and approved by qualified testing and inspecting agency for firestop systems indicated.

2.3 SLEEVES FOR RACEWAYS AND CABLES

- A. Steel Pipe Sleeves: ASTM A 53/A 53M, Type E, Grade B, Schedule 40, galvanized steel, plain ends.
- B. Cast-Iron Pipe Sleeves: Cast or fabricated "wall pipe," equivalent to ductile-iron pressure pipe, with plain ends and integral waterstop, unless otherwise indicated.
- C. Coordinate sleeve selection and application with selection and application of firestopping.

2.4 SLEEVE SEALS

- A. Description: Modular sealing device, designed for field assembly, to fill annular space between sleeve and raceway or cable.
 - 1. Sealing Elements: EPDM interlocking links shaped to fit surface of cable or conduit. Include type and number required for material and size of raceway or cable.
 - 2. Pressure Plates: Plastic. Include two for each sealing element.
 - 3. Connecting Bolts and Nuts: Carbon steel with corrosion-resistant coating of length required to secure pressure plates to sealing elements. Include one for each sealing element.

PART 3 - EXECUTION

3.1 THROUGH-PENETRATION FIRESTOP SYSTEM INSTALLATION

- A. General: Install through-penetration firestop systems to comply with Part 1 "Performance Requirements" Article and with firestop system manufacturer's written installation instructions and published drawings for products and applications indicated.
- B. Install forming/damming/backing materials and other accessories of types required to support fill materials during their application and in the position needed to produce cross-sectional shapes and depths required to achieve fire ratings indicated.
 - 1. After installing fill materials and allowing them to fully cure, remove combustible forming materials and other accessories not indicated as permanent components of firestop systems.
- C. Install fill materials for firestop systems by proven techniques to produce the following results:

**Okaloosa County TDC – Emerald Coast Convention Center
Restroom Renovations and Meeting Room Counters**

1. Fill voids and cavities formed by openings, forming materials, accessories, and penetrating items as required to achieve fire-resistance ratings indicated.
 2. Apply materials so they contact and adhere to substrates formed by openings and penetrating items.
 3. For fill materials that will remain exposed after completing Work, finish to produce smooth, uniform surfaces that are flush with adjoining finishes.
- D. Identification: Identify through-penetration firestop systems with preprinted metal or plastic labels. Attach labels permanently to surfaces adjacent to and within 6 inches (150 mm) of edge of the firestop systems so that labels will be visible to anyone seeking to remove penetrating items or firestop systems. Use mechanical fasteners for metal labels. Include the following information on labels:
1. The words "Warning - Through-Penetration Firestop System - Do Not Disturb. Notify Building Management of Any Damage."
 2. Contractor's name, address, and phone number.
 3. Through-penetration firestop system designation of applicable testing and inspecting agency.
 4. Date of installation.
 5. Through-penetration firestop system manufacturer's name.
 6. Installer's name.

3.2 FIELD QUALITY CONTROL

- A. Inspecting Agency: Owner will engage an independent inspecting agency to inspect through-penetration firestops. Independent inspecting agency shall comply with ASTM E 2174 requirements including those related to qualifications, conducting inspections, and preparing test reports.
- B. Where deficiencies are found, repair or replace through-penetration firestop systems so they comply with requirements.
- C. Proceed with enclosing through-penetration firestop systems with other construction only after inspection reports are issued and firestop installations comply with requirements.

3.3 SLEEVE INSTALLATION FOR ELECTRICAL PENETRATIONS

- A. Electrical penetrations occur when raceways, cables, wireways, cable trays, or busways penetrate concrete slabs, concrete or masonry walls, or fire-rated floor and wall assemblies.
- B. Coordinate sleeve selection and application with selection and application of firestopping.
- C. Concrete Slabs and Walls: Install sleeves for penetrations unless core-drilled holes or formed openings are used. Install sleeves during erection of slabs and walls.

**Okaloosa County TDC – Emerald Coast Convention Center
Restroom Renovations and Meeting Room Counters**

- D. Fire-Rated Assemblies: Install sleeves for penetrations of fire-rated floor and wall assemblies unless openings compatible with firestop system used are fabricated during construction of floor or wall.
- E. Cut sleeves to length for mounting flush with both surfaces of walls.
- F. Extend sleeves installed in floors 2 inches (50 mm) above finished floor level.
- G. Size pipe sleeves to provide 1/4-inch (6.4-mm) annular clear space between sleeve and raceway or cable unless sleeve seal is to be installed.
- H. Seal space outside of sleeves with grout for penetrations of concrete and masonry and with approved joint compound for gypsum board assemblies.
- I. Interior Penetrations of Non-Fire-Rated Walls and Floors: Seal annular space between sleeve and raceway or cable, using joint sealant appropriate for size, depth, and location of joint.
- J. Fire-Rated-Assembly Penetrations: Maintain indicated fire rating of walls, partitions, ceilings, and floors at raceway and cable penetrations. Install sleeves and seal raceway and cable penetration sleeves with firestop materials.
- K. Roof-Penetration Sleeves: Seal penetration of individual raceways and cables with flexible boot-type flashing units applied in coordination with roofing work.
- L. Aboveground, Exterior-Wall Penetrations: Seal penetrations using sleeves and mechanical sleeve seals. Select sleeve size to allow for 1-inch (25-mm) annular clear space between pipe and sleeve for installing mechanical sleeve seals.
- M. Underground, Exterior-Wall Penetrations: Install "wall pipes" for sleeves. Size sleeves to allow for 1-inch (25-mm) annular clear space between raceway or cable and sleeve for installing mechanical sleeve seals.

END OF SECTION 260523

**Okaloosa County TDC – Emerald Coast Convention Center
Restroom Renovations and Meeting Room Counters**

Page left bank

**Okaloosa County TDC – Emerald Coast Convention Center
Restroom Renovations and Meeting Room Counters**

SECTION 260526 - GROUNDING AND BONDING FOR ELECTRICAL SYSTEMS

PART 1 - GENERAL

1.1 SUMMARY

- A. This Section includes methods and materials for grounding systems and equipment.

1.2 SUBMITTALS

- A. Product Data: For each type of product indicated.
- B. Field quality-control test reports.

1.3 QUALITY ASSURANCE

- A. Electrical Components, Devices, and Accessories: Listed and labeled as defined in NFPA 70, Article 100, by a testing agency acceptable to authorities having jurisdiction, and marked for intended use.
- B. Comply with UL 467 for grounding and bonding materials and equipment.

PART 2 - PRODUCTS

2.1 CONDUCTORS

- A. Insulated Conductors: Copper wire or cable insulated for 600 V unless otherwise required by applicable Code or authorities having jurisdiction.
- B. Bare Copper Conductors:
 - 1. Solid Conductors: ASTM B 3.
 - 2. Stranded Conductors: ASTM B 8.
 - 3. Tinned Conductors: ASTM B 33.
 - 4. Bonding Cable: 28 kcmil, 14 strands of No. 17 AWG conductor, 1/4 inch (6 mm) in diameter.
 - 5. Bonding Conductor: No. 4 or No. 6 AWG, stranded conductor.
 - 6. Bonding Jumper: Copper tape, braided conductors, terminated with copper ferrules; 1-5/8 inches (41 mm) wide and 1/16 inch (1.6 mm) thick.
 - 7. Tinned Bonding Jumper: Tinned-copper tape, braided conductors, terminated with copper ferrules; 1-5/8 inches (41 mm) wide and 1/16 inch (1.6 mm) thick.

**Okaloosa County TDC – Emerald Coast Convention Center
Restroom Renovations and Meeting Room Counters**

2.2 CONNECTORS

- A. Listed and labeled by a nationally recognized testing laboratory acceptable to authorities having jurisdiction for applications in which used, and for specific types, sizes, and combinations of conductors and other items connected.
- B. Bolted Connectors for Conductors and Pipes: Copper or copper alloy, bolted pressure-type, with at least two bolts.
 - 1. Pipe Connectors: Clamp type, sized for pipe.
- C. Welded Connectors: Exothermic-welding kits of types recommended by kit manufacturer for materials being joined and installation conditions.

2.3 GROUNDING ELECTRODES

- A. Ground Rods: Copper-clad steel, sectional type; 3/4 inch in diameter by 20 feet long (19 mm by 3 m).

PART 3 - EXECUTION

3.1 APPLICATIONS

- A. Conductors: Install solid conductor for No. 8 AWG and smaller, and stranded conductors for No. 6 AWG and larger, unless otherwise indicated.
- B. Underground Grounding Conductors: Install insulated copper conductor, No. 2/0 AWG minimum. Bury at least 24 inches (600 mm) below grade.
- C. Isolated Grounding Conductors: Green-colored insulation with continuous yellow stripe. On feeders with isolated ground, identify grounding conductor where visible to normal inspection, with alternating bands of green and yellow tape, with at least three bands of green and two bands of yellow.
- D. Conductor Terminations and Connections:
 - 1. Pipe and Equipment Grounding Conductor Terminations: Bolted connectors.
 - 2. Underground Connections: Welded connectors, except at test wells and as otherwise indicated.
 - 3. Connections to Ground Rods at Test Wells: Bolted connectors.
 - 4. Connections to Structural Steel: Welded connectors.

**Okaloosa County TDC – Emerald Coast Convention Center
Restroom Renovations and Meeting Room Counters**

3.2 EQUIPMENT GROUNDING

- A. Install insulated equipment grounding conductors with the following items, in addition to those required by NFPA 70:
1. Feeders and branch circuits.
 2. Lighting circuits.
 3. Receptacle circuits.
 4. Single-phase motor and appliance branch circuits.
 5. Three-phase motor and appliance branch circuits.
 6. Flexible raceway runs.
 7. Computer and Rack-Mounted Electronic Equipment Circuits: Install insulated equipment grounding conductor in branch-circuit runs from equipment-area power panels and power-distribution units.
- B. Air-Duct Equipment Circuits: Install insulated equipment grounding conductor to duct-mounted electrical devices operating at 120 V and more, including air cleaners, heaters, dampers, humidifiers, and other duct electrical equipment. Bond conductor to each unit and to air duct and connected metallic piping.
- C. Water Heater and Heat-Tracing Cables: Install a separate insulated equipment grounding conductor to each electric water heater and heat-tracing cable. Bond conductor to heater units, piping, connected equipment, and components.
- D. Isolated Equipment Enclosure Circuits: For designated equipment supplied by a branch circuit or feeder, isolate equipment enclosure from supply circuit raceway with a nonmetallic raceway fitting listed for the purpose. Install fitting where raceway enters enclosure, and install a separate insulated equipment grounding conductor. Isolate conductor from raceway and from panelboard grounding terminals. Terminate at equipment grounding conductor terminal of the applicable derived system or service, unless otherwise indicated.
- E. Signal and Communication Equipment: For telephone, alarm, voice and data, and other communication equipment, provide No. 4 AWG minimum insulated grounding conductor in raceway from grounding electrode system to each service location, terminal cabinet, wiring closet, and central equipment location.
1. Service and Central Equipment Locations and Wiring Closets: Terminate grounding conductor on a 1/4-by-2-by-12-inch (6-by-50-by-300-mm) grounding bus.
 2. Terminal Cabinets: Terminate grounding conductor on cabinet grounding terminal.
- F. Metal Poles Supporting Outdoor Lighting Fixtures: Install grounding electrode and a separate insulated equipment grounding conductor in addition to grounding conductor installed with branch-circuit conductors.

**Okaloosa County TDC – Emerald Coast Convention Center
Restroom Renovations and Meeting Room Counters**

3.3 INSTALLATION

- A. Grounding Conductors: Route along shortest and straightest paths possible, unless otherwise indicated or required by Code. Avoid obstructing access or placing conductors where they may be subjected to strain, impact, or damage.
- B. Ground Rods: Drive rods until tops are 2 inches (50 mm) below finished floor or final grade, unless otherwise indicated.
 - 1. Interconnect ground rods with grounding electrode conductor below grade and as otherwise indicated. Make connections without exposing steel or damaging coating, if any.
 - 2. For grounding electrode system, install at least two rods spaced at least one-rod length from each other and located at least the same distance from other grounding electrodes, and connect to the service grounding electrode conductor.
- C. Bonding Straps and Jumpers: Install in locations accessible for inspection and maintenance, except where routed through short lengths of conduit.
 - 1. Bonding to Structure: Bond straps directly to basic structure, taking care not to penetrate any adjacent parts.
 - 2. Bonding to Equipment Mounted on Vibration Isolation Hangers and Supports: Install so vibration is not transmitted to rigidly mounted equipment.
 - 3. Use exothermic-welded connectors for outdoor locations, but if a disconnect-type connection is required, use a bolted clamp.
- D. Grounding and Bonding for Piping: Provide grounding for all new metal pipes.
- E. Bonding Interior Metal Ducts: Bond metal air ducts to equipment grounding conductors of associated fans, blowers, electric heaters, and air cleaners. Install bonding jumper to bond across flexible duct connections to achieve continuity.

3.4 FIELD QUALITY CONTROL

- A. Perform the following tests and inspections and prepare test reports:
 - 1. After installing new grounding electrode systems but before permanent electrical circuits have been energized, test for compliance with requirements.
 - 2. Test completed grounding system at each location where a maximum ground-resistance level is specified, at service disconnect enclosure grounding terminal, and at ground test wells.
 - a. Measure ground resistance not less than two full days after last trace of precipitation and without soil being moistened by any means other than natural drainage or seepage and without chemical treatment or other artificial means of reducing natural ground resistance.
 - b. Perform tests by fall-of-potential method according to IEEE 81.

**Okaloosa County TDC – Emerald Coast Convention Center
Restroom Renovations and Meeting Room Counters**

- B. Report measured ground resistances that exceed 5 ohms.

END OF SECTION 260526

**Okaloosa County TDC – Emerald Coast Convention Center
Restroom Renovations and Meeting Room Counters**

Page left blank

**Okaloosa County TDC – Emerald Coast Convention Center
Restroom Renovations and Meeting Room Counters**

SECTION 260529 - ELECTRICAL SUPPORTS

PART 1 - GENERAL

1.1 SUMMARY

- A. This Section includes the following:
 - 1. Hangers and supports for electrical equipment and systems.
 - 2. Construction requirements for concrete bases.

1.2 SUBMITTALS

- A. Product Data: Illustrate and indicate style, material, strength, fastening provision, and finish for each type and size of support component used.
- B. Shop Drawings for Supports: For supports and their attachments to structure not defined on Drawings, identify hardware, and indicate analysis, forces, strengths, materials, and dimensions, signed and sealed by a qualified professional engineer.

1.3 QUALITY ASSURANCE

- A. Welding: Qualify procedures and personnel according to AWS D1.1/D1.1M, "Structural Welding Code - Steel."

PART 2 - PRODUCTS

2.1 MANUFACTURERS

- A. In other Part 2 articles where titles below introduce lists, the following requirements apply to product selection:
 - 1. Available Manufacturers: Subject to compliance with requirements, manufacturers offering products that may be incorporated into the Work include, but are not limited to, manufacturers specified.

2.2 SUPPORT, ANCHORAGE, AND ATTACHMENT COMPONENTS

- A. Rated Strength: Adequate in tension, shear, and pullout force to resist maximum loads calculated or imposed under this Project, with a minimum structural safety factor of five the applied force.

**Okaloosa County TDC – Emerald Coast Convention Center
Restroom Renovations and Meeting Room Counters**

- B. Steel Slotted Support Systems: Comply with MFMA-3, factory-fabricated components for field assembly, and provide finish suitable for the environment in which installed.
1. Available Manufacturers:
 - a. Cooper B-Line; a division of Cooper Industries.
 - b. ERICO International Corporation.
 - c. Allied Support Systems; Power-Strut Unit.
 - d. GS Metals Corp.
 - e. Michigan Hanger Co., Inc.; O-Strut Div.
 - f. National Pipe Hanger Corp.
 - g. Thomas & Betts Corporation.
 - h. Unistrut; Tyco International, Ltd.
 - i. Wesanco, Inc.
 2. Channel Dimensions: Selected for structural loading.
- C. Raceway and Cable Supports: As described in NECA 1.
- D. Conduit and Cable Support Devices: Steel and malleable-iron hangers, clamps, and associated fittings, designed for types and sizes of raceway or cable to be supported.
- E. Support for Conductors in Vertical Conduit: Factory-fabricated assembly consisting of threaded body and insulating wedging plug or plugs for non-armored electrical conductors or cables in riser conduits. Plugs shall have number, size, and shape of conductor gripping pieces as required to suit individual conductors or cables supported. Body shall be malleable iron.
- F. Structural Steel for Fabricated Supports and Restraints: ASTM A 36/A 36M, steel plates, shapes, and bars; black and galvanized.
- G. Mounting, Anchoring, and Attachment Components: Items for fastening electrical items or their supports to building surfaces include the following:
1. Mechanical-Expansion Anchors: Insert-wedge-type, zinc-coated steel, for use in hardened portland cement concrete with tension, shear, and pullout capacities appropriate for supported loads and building materials in which used.
 - a. Available Manufacturers:
 - 1) Cooper B-Line; a division of Cooper Industries.
 - 2) Empire Tool and Manufacturing Co., Inc.
 - 3) Hilti, Inc.
 - 4) ITW Construction Products.
 - 5) MKT Fastening, LLC.
 - 6) Powers Fasteners.
 2. Concrete Inserts: Steel or malleable-iron slotted-support-system units similar to MSS Type 18; complying with MFMA-3 or MSS SP-58.

**Okaloosa County TDC – Emerald Coast Convention Center
Restroom Renovations and Meeting Room Counters**

3. Clamps for Attachment to Steel Structural Elements: MSS SP-58, type suitable for attached structural element.
4. Through Bolts: Structural type, hex head, high strength. Comply with ASTM A 325.
5. Toggle Bolts: All-steel springhead type.
6. Hanger Rods: Threaded steel.

2.3 FABRICATED METAL EQUIPMENT SUPPORT ASSEMBLIES

- A. Description: Welded or bolted, structural-steel shapes, shop or field fabricated to fit dimensions of supported equipment.

PART 3 - EXECUTION

3.1 APPLICATION

- A. Comply with NECA 1 for application of hangers and supports for electrical equipment and systems, unless requirements in this Section or applicable Code are stricter.

3.2 SUPPORT INSTALLATION

- A. Comply with NECA 1 for installation requirements, except as specified in this Article.
- B. Raceway Support Methods: In addition to methods described in NECA 1, EMT, IMC, and RMC may be supported by openings through structure members, as permitted in NFPA 70.
- C. Strength of Support Assemblies: Where not indicated, select sizes of components so strength will be adequate to carry present and future static loads within specified loading limits. Minimum static design load used for strength determination shall be weight of supported components plus 200 lb (90 kg).
- D. Mounting and Anchorage of Surface-Mounted Equipment and Components: Anchor and fasten electrical items and their supports to building structural elements by the following methods, unless otherwise indicated by Code:
 1. To Wood: Fasten with lag screws or through bolts.
 2. To New Concrete: Bolt to concrete inserts.
 3. To Masonry: Approved toggle-type bolts on hollow masonry units and expansion anchor fasteners on solid masonry units.
 4. To Existing Concrete: Expansion anchor fasteners.
 5. To Steel: Beam clamps (MSS Type 19, 21, 23, 25, or 27) complying with MSS SP-69.
 6. To Light Steel: Sheet metal screws.
 7. Items Mounted on Hollow Walls and Nonstructural Building Surfaces: Mount on slotted-channel racks attached to substrate.

**Okaloosa County TDC – Emerald Coast Convention Center
Restroom Renovations and Meeting Room Counters**

- E. Drill holes for expansion anchors in concrete at locations and to depths that avoid reinforcing bars.

3.3 INSTALLATION OF FABRICATED METAL SUPPORTS

- A. Cut, fit, and place miscellaneous metal supports accurately in location, alignment, and elevation to support and anchor electrical materials and equipment.
- B. Field Welding: Comply with AWS D1.1/D1.1M.

3.4 CONCRETE BASES

- A. Concrete Bases: Anchor equipment to concrete base according to equipment manufacturer's written instructions.
- B. Construct concrete bases of dimensions indicated but not less than 4 inches (100 mm) larger in both directions than supported unit, and so expansion anchors will be a minimum of 10 bolt diameters from edge of the base.
 - 1. Install dowel rods to connect concrete base to concrete floor. Unless otherwise indicated, install dowel rods on 18-inch (450-mm) centers around full perimeter of the base.
 - 2. Install epoxy-coated anchor bolts for supported equipment that extend through concrete base, and anchor into structural concrete floor.
 - 3. Place and secure anchorage devices. Use supported equipment manufacturer's setting drawings, templates, diagrams, instructions, and directions furnished with items to be embedded.
 - 4. Install anchor bolts to elevations required for proper attachment to supported equipment.
 - 5. Install anchor bolts according to anchor-bolt manufacturer's written instructions.
 - 6. Use 3000-psi (20.7-MPa), 28-day compressive-strength concrete.

3.5 INSTALLATION OF SEISMIC-RESTRAINT COMPONENTS

- A. Install bushing assemblies for anchor bolts for floor-mounted equipment, arranged to provide resilient media between anchor bolt and mounting hole in concrete base.
- B. Install bushing assemblies for mounting bolts for wall-mounted equipment, arranged to provide resilient media where equipment or equipment-mounting channels are attached to wall.
- C. Restraint Cables: Provide slack within maximums recommended by manufacturer.
- D. Attachment to Structure: If specific attachment is not indicated, anchor bracing to structure at flanges of beams, upper truss chords of bar joists, or at concrete members.

**Okaloosa County TDC – Emerald Coast Convention Center
Restroom Renovations and Meeting Room Counters**

3.6 ACCOMMODATION OF DIFFERENTIAL SEISMIC MOTION

- A. Make flexible connections in runs of raceways, cables, wireways, cable trays, and busways where they cross expansion joints, where adjacent sections or branches are supported by different structural elements, and where they terminate with connection to electrical equipment that is anchored to a different structural element from the one supporting them as they approach equipment.

END OF SECTION 260529

**Okaloosa County TDC – Emerald Coast Convention Center
Restroom Renovations and Meeting Room Counters**

Page left blank

**Okaloosa County TDC – Emerald Coast Convention Center
Restroom Renovations and Meeting Room Counters**

SECTION 260533 - RACEWAYS AND BOXES FOR ELECTRICAL SYSTEMS

PART 1 - GENERAL

1.1 SUMMARY

- A. This Section includes raceways, fittings, boxes, enclosures, and cabinets for electrical wiring.
- B. See Division 26 Section "Firestop Systems and Sleeves" for firestopping materials and installation at penetrations through walls, ceilings, and other fire-rated elements.
- C. See Division 26 Section "Electric Methods and Basic Materials" for supports, anchors, and identification products.
- D. See Division 26 Section "Wiring Devices" for devices installed in boxes and for floor-box service fittings.

1.2 SUBMITTALS

- A. Product Data: For surface raceways, wireways and fittings, floor boxes, hinged-cover enclosures, and cabinets indicated.
- B. Shop Drawings: Show fabrication and installation details of components for raceways, fittings, boxes, enclosures, and cabinets.

1.3 QUALITY ASSURANCE

- A. Electrical Components, Devices, and Accessories: Listed and labeled as defined in NFPA 70, Article 100, by a testing agency acceptable to authorities having jurisdiction, and marked for intended use.
- B. Comply with NFPA 70.

PART 2 - PRODUCTS

2.1 MANUFACTURERS

- A. In other Part 2 articles where subparagraph titles below introduce lists, the following requirements apply for product selection:

**Okaloosa County TDC – Emerald Coast Convention Center
Restroom Renovations and Meeting Room Counters**

Available Manufacturers: Subject to compliance with requirements, manufacturers offering products that may be incorporated into the Work include, but are not limited to, the manufacturers specified.

2.2 METAL CONDUIT AND TUBING

A. Manufacturers:

1. AFC Cable Systems, Inc.
2. Alflex Inc.
3. Anamet Electrical, Inc.; Anaconda Metal Hose.
4. Electri-Flex Co.
5. Grinnell Co./Tyco International; Allied Tube and Conduit Div.
6. LTV Steel Tubular Products Company.
7. Manhattan/CDT/Cole-Flex.
8. O-Z Gedney; Unit of General Signal.
9. Wheatland Tube Co.

B. Rigid Steel Conduit: ANSI C80.1.

C. EMT and Fittings: ANSI C80.3.

1. Fittings: Steel, Set-screw or compression type. No die-cast.

D. LFMC: Flexible steel conduit with PVC jacket.

E. Fittings: NEMA FB 1; compatible with conduit and tubing materials.

2.3 NONMETALLIC CONDUIT AND TUBING

A. Manufacturers:

1. American International.
2. Anamet Electrical, Inc.; Anaconda Metal Hose.
3. Arnco Corp.
4. Cantex Inc.
5. Certainteed Corp.; Pipe & Plastics Group.
6. Condux International.
7. ElecSYS, Inc.
8. Electri-Flex Co.
9. Lamson & Sessions; Carlon Electrical Products.
10. Manhattan/CDT/Cole-Flex.
11. RACO; Division of Hubbell, Inc.
12. Spiralduct, Inc./AFC Cable Systems, Inc.
13. Thomas & Betts Corporation.

B. RNC: NEMA TC 2, Schedule 40 and Schedule 80 PVC.

**Okaloosa County TDC – Emerald Coast Convention Center
Restroom Renovations and Meeting Room Counters**

- C. RNC Fittings: NEMA TC 3; match to conduit or tubing type and material.

2.4 METAL WIREWAYS

- A. Manufacturers:

1. Hoffman.
2. Square D.

- B. Material and Construction: Sheet metal sized and shaped as indicated.

- C. Fittings and Accessories: Include couplings, offsets, elbows, expansion joints, adapters, hold-down straps, end caps, and other fittings to match and mate with wireways as required for complete system.

- D. Select features, unless otherwise indicated, as required to complete wiring system and to comply with NFPA 70.

- E. Wireway Covers: Screw-cover type.

- F. Finish: Manufacturer's standard enamel finish.

2.5 BOXES, ENCLOSURES, AND CABINETS

- A. Manufacturers:

1. Cooper Crouse-Hinds; Div. of Cooper Industries, Inc.
2. Emerson/General Signal; Appleton Electric Company.
3. Erickson Electrical Equipment Co.
4. Hoffman.
5. Hubbell, Inc.; Killark Electric Manufacturing Co.
6. O-Z/Gedney; Unit of General Signal.
7. RACO; Division of Hubbell, Inc.
8. Thomas & Betts Corporation.
9. Walker Systems, Inc.; Wiremold Company (The).

- B. Sheet Metal Outlet and Device Boxes: NEMA OS 1.

- C. Cast-Metal Outlet and Device Boxes: NEMA FB 1, Type FD, with gasketed cover.

- D. Nonmetallic Outlet and Device Boxes: NEMA OS 2.

- E. Small Sheet Metal Pull and Junction Boxes: NEMA OS 1.

- F. Cast-Metal Pull and Junction Boxes: NEMA FB 1, cast aluminum with gasketed cover.

- G. Hinged-Cover Enclosures: NEMA 250, Type 1, with continuous hinge cover and flush latch.

**Okaloosa County TDC – Emerald Coast Convention Center
Restroom Renovations and Meeting Room Counters**

1. Metal Enclosures: Steel, finished inside and out with manufacturer's standard enamel.
2. Nonmetallic Enclosures: Plastic, finished inside with radio-frequency-resistant paint.

H. Cabinets: NEMA 250, Type 1, galvanized steel box with removable interior panel and removable front, finished inside and out with manufacturer's standard enamel. Hinged door in front cover with flush latch and concealed hinge. Key latch to match panelboards. Include metal barriers to separate wiring of different systems and voltage and include accessory feet where required for freestanding equipment.

2.6 FACTORY FINISHES

- A. Finish: For raceway, enclosure, or cabinet components, provide manufacturer's standard paint applied to factory-assembled surface raceways, enclosures, and cabinets before shipping.

PART 3 - EXECUTION

3.1 RACEWAY APPLICATION

A. Outdoors:

1. Exposed: Rigid steel.
2. Concealed: Rigid steel.
3. Underground, Single Run: SCH 40 PVC.
4. Underground, Grouped: SCH 40 PVC.
5. Connection to Vibrating Equipment (Including Transformers and Hydraulic, Pneumatic, Electric Solenoid, or Motor-Driven Equipment): LFMC.
6. Boxes and Enclosures: NEMA 250, Type 3R.

B. Indoors:

1. Exposed: EMT in unfinished areas where shown or permitted.
2. Concealed: EMT.
3. Connection to Vibrating Equipment (Including Transformers and Hydraulic, Pneumatic, Electric Solenoid, or Motor-Driven Equipment): FMC; except use LFMC in damp or wet locations or where exposed to view (not concealed).
4. Damp or Wet Locations: Rigid steel conduit.
5. Boxes and Enclosures: NEMA 250, Type 1, except as follows:
 - a. Damp or Wet Locations: NEMA 250, Type 4, nonmetallic.
6. Flexible metal conduit: Where applications are not concealed by the building construction, liquid tight flexible conduit and grounding type fittings shall be used and system shall be fully bonded.

C. Minimum Raceway Size: 1/2-inch trade size (DN 16), except underground shall be 3/4" minimum.

D. Raceway Fittings: Compatible with raceways and suitable for use and location.

**Okaloosa County TDC – Emerald Coast Convention Center
Restroom Renovations and Meeting Room Counters**

1. Steel Conduit: Use threaded rigid steel conduit fittings, unless otherwise indicated.

3.2 INSTALLATION

- A. Keep raceways at least 6 inches (150 mm) away from parallel runs of flues and steam or hot-water pipes. Install horizontal raceway runs above water and steam piping.
- B. Complete raceway installation before starting conductor installation.
- C. Support raceways as required by NEC.
- D. Install temporary closures to prevent foreign matter from entering raceways.
- E. Protect stub-ups from damage where conduits rise through floor slabs. Arrange so curved portions of bends are not visible above finished slab.
- F. Make bends and offsets so ID is not reduced. Keep legs of bends in same plane and keep straight legs of offsets parallel, unless otherwise indicated.
- G. Conceal conduit and EMT within finished walls, ceilings, and floors, unless otherwise indicated.
 1. Install concealed raceways with a minimum of bends in shortest practical distance, considering type of building construction and obstructions, unless otherwise indicated.
- H. Raceways Embedded in Slabs: Install in middle 1/3 of slab thickness where practical and leave at least 2 inches (50 mm) of concrete cover.
 1. Secure raceways to reinforcing rods to prevent sagging or shifting during concrete placement.
 2. Space raceways laterally to prevent voids in concrete.
 3. Run conduit larger than 1-inch trade size (DN 27) parallel or at right angles to main reinforcement. Where at right angles to reinforcement, place conduit close to slab support.
 4. Change from nonmetallic tubing to Schedule 80 nonmetallic conduit, rigid steel conduit, or IMC before rising above floor, except PVC branch circuits may rise concealed in walls to first box maximum 48" AFF.
- I. Install exposed raceways parallel or at right angles to nearby surfaces or structural members and follow surface contours as much as possible.
 1. Run parallel or banked raceways together on common supports.
 2. Make parallel bends in parallel or banked runs. Use factory elbows only where elbows can be installed parallel; otherwise, provide field bends for parallel raceways.
- J. Join raceways with fittings designed and approved for that purpose and make joints tight.
 1. Use insulating bushings to protect conductors.

**Okaloosa County TDC – Emerald Coast Convention Center
Restroom Renovations and Meeting Room Counters**

- K. Tighten set screws of threadless fittings with suitable tools.
 - L. Terminations:
 - 1. Where raceways are terminated with locknuts and bushings, align raceways to enter squarely and install locknuts with dished part against box. Use two locknuts, one inside and one outside box.
 - 2. Where raceways are terminated with threaded hubs, screw raceways or fittings tightly into hub so end bears against wire protection shoulder. Where chase nipples are used, align raceways so coupling is square to box; tighten chase nipple so no threads are exposed.
 - M. Install pull cords in empty raceways. Use polypropylene or monofilament plastic line with not less than 200-lb (90-kg) tensile strength. Leave at least 12 inches (300 mm) of slack at each end of pull cord.
 - N. Install raceway sealing fittings at suitable, approved, and accessible locations and fill them with UL-listed sealing compound. For concealed raceways, install each fitting in a flush steel box with a blank cover plate having a finish similar to that of adjacent plates or surfaces. Install raceway sealing fittings at the following points:
 - 1. Where conduits pass from warm to cold locations, such as boundaries of refrigerated spaces.
 - 2. Where otherwise required by NFPA 70.
 - O. Stub-up Connections: Extend conduits through concrete floor for connection to freestanding equipment. Install with an adjustable top or coupling threaded inside for plugs set flush with finished floor. Extend conductors to equipment with rigid steel conduit; FMC may be used 6 inches (150 mm) above the floor. Install screwdriver-operated, threaded plugs flush with floor for future equipment connections.
 - P. Flexible Connections: Use maximum of 72 inches (1830 mm) of flexible conduit for recessed and semirecessed lighting fixtures; for equipment subject to vibration, noise transmission, or movement; and for all motors. Use LFMC in damp or wet locations or where exposed to view (not concealed). Install separate ground conductor across flexible connections.
 - Q. Surface Raceways: Install a separate, green, ground conductor in raceways from junction box supplying raceways to receptacle or fixture ground terminals.
 - R. Install hinged-cover enclosures and cabinets plumb. Support at each corner.
- 3.3 PROTECTION
- A. Provide final protection and maintain conditions that ensure coatings, finishes, and cabinets are without damage or deterioration at time of Substantial Completion.
 - 1. Repair damage to galvanized finishes with zinc-rich paint recommended by manufacturer.

**Okaloosa County TDC – Emerald Coast Convention Center
Restroom Renovations and Meeting Room Counters**

2. Repair damage to PVC or paint finishes with matching touchup coating recommended by manufacturer.

END OF SECTION 260533

**Okaloosa County TDC – Emerald Coast Convention Center
Restroom Renovations and Meeting Room Counters**

Page left blank

**Okaloosa County TDC – Emerald Coast Convention Center
Restroom Renovations and Meeting Room Counters**

SECTION 260553 – IDENTIFICATION FOR ELECTRICAL SYSTEMS

PART 1 - GENERAL

1.1 SUMMARY

A. This Section includes the following:

1. Identification for conductors and communication and control cable.
2. Warning labels and signs.
3. Equipment identification labels.

1.2 SUBMITTALS

A. Product Data: For each electrical identification product indicated.

1.3 QUALITY ASSURANCE

A. Comply with ANSI A13.1.

1.4 COORDINATION

A. Coordinate identification names, abbreviations, colors, and other features with requirements in the Contract Documents, Shop Drawings, manufacturer's wiring diagrams, and the Operation and Maintenance Manual, and with those required by codes, standards, and 29 CFR 1910.145. Use consistent designations throughout Project.

PART 2 - PRODUCTS

2.1 CONDUCTOR AND COMMUNICATION- AND CONTROL-CABLE IDENTIFICATION MATERIALS

A. Marker Tape: Vinyl or vinyl -cloth, self-adhesive wraparound type, with circuit identification legend machine printed by thermal transfer or equivalent process.

2.2 WARNING LABELS AND SIGNS

A. Comply with NFPA 70 and 29 CFR 1910.145.

B. Self-Adhesive Warning Labels: Factory printed, multicolor, pressure-sensitive adhesive labels, configured for display on front cover, door, or other access to equipment, unless otherwise indicated.

**Okaloosa County TDC – Emerald Coast Convention Center
Restroom Renovations and Meeting Room Counters**

- C. Baked-Enamel Warning Signs: Preprinted aluminum signs, punched or drilled for fasteners, with colors, legend, and size required for application. 1/4-inch (6.4-mm) grommets in corners for mounting. Nominal size, 7 by 10 inches (180 by 250 mm).
- D. Fasteners for Signs: Self-tapping, stainless-steel screws or stainless-steel machine screws with nuts and flat and lock washers.
- E. Warning label and sign shall include, but are not limited to, the following legends:
 - 1. Multiple Power Source Warning: "DANGER - ELECTRICAL SHOCK HAZARD - EQUIPMENT HAS MULTIPLE POWER SOURCES."
 - 2. Workspace Clearance Warning: "WARNING - OSHA REGULATION - AREA IN FRONT OF ELECTRICAL EQUIPMENT MUST BE KEPT CLEAR FOR 36 INCHES (915 mm)."

2.3 EQUIPMENT IDENTIFICATION LABELS

- A. Adhesive Film Label with Clear Protective Overlay: Machine printed, in black, by thermal transfer or equivalent process. Minimum letter height shall be 3/8 inch (10 mm). Overlay shall provide a weatherproof and ultraviolet-resistant seal for label.
- B. Self-Adhesive, Engraved, Laminated Acrylic or Melamine Label: Adhesive backed, with white letters on a dark-gray background. Minimum letter height shall be 3/8 inch (10 mm).

PART 3 - EXECUTION

3.1 APPLICATION

- A. Auxiliary Electrical Systems Conductor and Cable Identification: Use marker tape to identify field-installed alarm, control, signal, sound, intercommunications, voice, and data wiring connections.
 - 1. Identify conductors, cables, and terminals in enclosures and at junctions, terminals, and cable pull points. Identify by system and circuit designation.
 - 2. Use system of designations that is uniform and consistent with system used by manufacturer for factory-installed connections.
- B. Warning Labels for Indoor Cabinets, Boxes, and Enclosures for Power and Lighting: Comply with 29 CFR 1910.145 and apply baked-enamel warning signs. Identify system voltage with black letters on an orange background. Apply to exterior of door, cover, or other access.
 - 1. Equipment with Multiple Power or Control Sources: Apply to door or cover of equipment including, but not limited to, the following:
 - a. Power transfer switches.
 - b. Controls with external control power connections.

**Okaloosa County TDC – Emerald Coast Convention Center
Restroom Renovations and Meeting Room Counters**

2. Equipment Requiring Workspace Clearance According to NFPA 70: Unless otherwise indicated, apply to door or cover of equipment but not on flush panelboards and similar equipment in finished spaces.
- C. Equipment Identification Labels: On each unit of equipment, install unique designation label that is consistent with wiring diagrams, schedules, and Operation and Maintenance Manual. Apply labels to disconnect switches and protection equipment, central or master units, control panels, control stations, terminal cabinets, and racks of each system. Systems include power, lighting, control, communication, signal, monitoring, and alarm systems unless equipment is provided with its own identification.
1. Labeling Instructions:
 - a. Indoor Equipment: Self-adhesive, engraved, laminated acrylic or melamine label. Unless otherwise indicated, provide a single line of text with 1/2-inch- (13-mm-) high letters on 1-1/2-inch- (38-mm-) high label; where 2 lines of text are required, use labels 2 inches (50 mm) high.
 - b. Outdoor Equipment: Engraved, laminated acrylic or melamine label, drilled for screw attachment.
 - c. Elevated Components: Increase sizes of labels and legend to those appropriate for viewing from the floor.
 2. Equipment to Be Labeled:
 - a. Panelboards, electrical cabinets, and enclosures.
 - b. Electrical switchgear and switchboards.
 - c. Disconnect switches.
 - d. Enclosed circuit breakers.
 - e. Motor starters.
 - f. Push-button stations.
 - g. Power transfer equipment.
 - h. Contactors.
 - i. Receptacles: Provide panel and circuit designation.
- 3.2 INSTALLATION
- A. Verify identity of each item before installing identification products.
 - B. Location: Install identification materials and devices at locations for most convenient viewing without interference with operation and maintenance of equipment.
 - C. Apply identification devices to surfaces that require finish after completing finish work.
 - D. Self-Adhesive Identification Products: Clean surfaces before application, using materials and methods recommended by manufacturer of identification device.
 - E. Attach nonadhesive signs and plastic labels with screws and auxiliary hardware appropriate to the location and substrate.

**Okaloosa County TDC – Emerald Coast Convention Center
Restroom Renovations and Meeting Room Counters**

- F. Color-Coding for Phase and Voltage Level Identification, 600 V and Less: Use the colors listed below for ungrounded service, feeder, and branch-circuit conductors.
 - 1. Color shall be factory applied.
 - 2. Colors for 208/120-V Circuits: (unless existing color code is different)
 - a. Phase A: Black.
 - b. Phase B: Red.
 - c. Phase C: Blue.
 - d. Neutral: White.

END OF SECTION 260553

**Okaloosa County TDC – Emerald Coast Convention Center
Restroom Renovations and Meeting Room Counters**

SECTION 260923 – LIGHTING CONTROLS AND DEVICES

PART 1 – GENERAL

1. SECTION INCLUDES

- A. Network lighting control system and components:
 - 1. Lighting management panels
 - 2. Lighting management modules
 - 3. Low voltage wall stations
 - 4. Wired sensors

2. RELATED DOCUMENTS

- A. Section 262726 Wiring Devices
- B. Section 265100 Interior Lighting Fixtures

1.3 SUMMARY

- A. The lighting control system specified in this section shall provide time-based, sensor-based (both occupancy and daylight), and manual lighting control
- B. The system shall be capable of turning lighting loads on/off as well as dimming lights (if lighting load is capable of being dimmed). Specific dimmers will be capable of “dimming lights to off”
- C. The system architecture shall be capable of enabling stand-alone groups (rooms) of devices to function in some default capacity, even if network connectivity to the greater system is lo

1.4 SUBMITTALS

- A. Product Datasheets (general device descriptions, dimensions, electrical specifications, wiring details, nomenclature)
- B. Riser Diagrams – typical per room type (detailed drawings showing interconnectivity of devices)
- C. Other Diagrams – as needed for special operation or interaction with other system(s)
- D. Example Contractor Startup/Commissioning Worksheet – must be completed prior to factory start-up

**Okaloosa County TDC – Emerald Coast Convention Center
Restroom Renovations and Meeting Room Counters**

- E. Hardware and Software Operation Manuals.
- F. Other operational descriptions as needed.

1.5 ON-SITE COMMISSIONING REQUIREMENTS

A. Pre-Wire Meeting Requirements

1. Certified Technician will meet onsite with the electrical contractors to coordinate installation details, review best practices, and discuss project specific challenges. This should happen prior to the installation being started, enabling the contractors to work with a lighting systems expert to prepare and make changes up prior to installation commencement.

- ##### B. A manufacturer's lighting systems team works onsite, after fixture and controls installation is completed. The project is reviewed and checked for proper wiring, installation and functionality of the system as a whole. Any problems are addressed and resolved with the onsite contractors. If fixture addressing is required, the manufacturer's technicians will perform this task in accordance with the intended lighting design.

C. Onsite programming requirements

1. Manufacturer's technicians map out the fixture locations and addresses within the lighting control software. Astronomic timeclock events, scenes, and schedules are programmed per a pre-defined script. These events, scenes, and schedules are tested and finalized for final approval by the project's ownership.

D. Training requirements

1. Manufacturer's technicians provide training for system users and the system maintenance team. The details of the technology are covered from a maintenance and troubleshooting point of view. This covers the lighting control system and its core functionality, with a focus on how to edit existing scenes and astronomic lighting events.
2. The manufacturer's representative will provide in-depth training to the end user on managing the specific control system, giving them the tools and knowledge to operate their system.

1.6 PROJECT CLOSEOUT DOCUMENTATION

A. Provide a factory published manual

1. Warranty
2. Technical support contact
3. Electronic manual on manufacturer's website for free download

1.5 QUALITY ASSURANCE

**Okaloosa County TDC – Emerald Coast Convention Center
Restroom Renovations and Meeting Room Counters**

- A. All components and the manufacturing facility where product was manufactured must be RoHS compliant.
- B. In high humidity or cold environments, the sensors shall be conformably coated and rated for condensing humidity and -40 degree Fahrenheit (and Celsius) operation.
- C. All applicable products must be UL / CUL Listed or other acceptable national testing organization.

1.6 PROJECT CONDITIONS

- A. Only install equipment after the following site conditions are maintained:
 - 1. Ambient Temperature 14 to 105 degrees F (-10 to 40 degrees C)
 - 2. Relative Humidity less than 90% non-condensing
- B. Standard electrical enclosures are permanently installed
- C. Equipment is protected from dust, debris and moisture

1.7 WARRANTY

- A. Five (5) year 100% parts replacement

1.8 MAINTENANCE & SUSTAINABILITY

- A. Provide new parts, upgrades, and/or replacements available for a minimum of 5 years available to the end user
- B. Provide free telephone technical support

PART 2 – PRODUCTS

2.1 MANUFACTURERS

- A. Basis of controls design Manufacturer:
*Acuity Brands, One Lithonia Way
Conyers GA 30012
www.acuitycontrols.com*
- B. Substitutions: Permitted with PRIOR APPROVAL ONLY:
 - 1. All substitutions must be submitted in writing for approval at least 14 days prior to bid date.
 - 2. Proposed substitute products must be documented with a line by line compliance review.

**Okaloosa County TDC – Emerald Coast Convention Center
Restroom Renovations and Meeting Room Counters**

3. Proposal substitute must provide contractor submittal revised lighting plans, lighting control risers and details.

2.2 SYSTEM REQUIREMENTS

- A. System shall have an architecture that is based upon two main concepts;
 1. intelligent lighting control devices
 2. standalone lighting control zones
- B. Intelligent lighting control devices shall consist of one or more basic lighting control components; occupancy sensors, photocell sensors, relays, dimming outputs, manual switch stations, and manual dimming stations. Combining one or more of these components into a single device enclosure should be permissible so as to minimize overall device count of system.
- C. System must interface directly with LED luminaires.
- D. Lighting control zones shall consist of one or more intelligent lighting control components, be capable of stand-alone operation, and be capable of being connected to a higher level network backbone.
- E. Individual lighting zones must continue to provide a user defined default level of lighting control in the event of a system communication failure with the backbone network or the management software becoming unavailable.
- F. Individual lighting zones shall be capable of being segmented into several “local” channels of occupancy, photocell, and switch functionality for more advanced configurations and sequences of operation.
- G. System shall be capable of operating a lighting control zone according to several sequences of operation. System shall be able to change a spaces sequence of operation according to a time schedule so as to enable customized time-of-day, day-of-week, utilization of a space. Note: Operating modes should be utilized only in manners consistent with local energy codes.
 1. Auto-On / Auto-Off (via occupancy sensors)
 - a. Zones with occupancy sensors automatically turn lights on when occupant is detected.
 - b. Zones with occupancy and/or photocell sensors turn lights off when vacancy or sufficient daylight is detected.
 - c. Pressing a switch will turn lights off. The lights will remain off regardless of occupancy until switch is pressed again, restoring the sensor to Automatic On functionality.
 2. Manual-On / Auto-Off (also called Semi-Automatic)
 - a. Pushing a switch will turn lights on.

**Okaloosa County TDC – Emerald Coast Convention Center
Restroom Renovations and Meeting Room Counters**

- b. Zones with occupancy and/or photocell sensors turn lights off when vacancy or sufficient daylight is detected.
 3. Manual-On to Auto-On/Auto-Off
 - a. Pushing a switch will turn lights on.
 - b. After initial lights on, zones with occupancy and/or photocell sensors turn lights on/off according to occupancy/vacancy and/or daylight conditions.
 - c. Sequence can be reset via scheduled (ex. daily each morning) events.
 4. Auto-to-Override On
 - a. Zones with occupancy sensors automatically turn lights on when occupant is detected.
 - b. Zone lighting then goes into an override on state for a set amount of time, or until the next time event returns the lighting to an auto-off style of control.
 - c. Sequence can be reset via scheduled (ex. daily each morning) events.
 5. Manual-to-Override On
 - a. Pushing a switch will turn lights on.
 - b. Zone lighting then goes into an override on state for a set amount of time or until the next time event returns the lighting to an auto-off style of control.
 - c. Sequence can be reset via scheduled (ex. daily each morning) events.
 6. Auto On / Predictive Off
 - a. Zones with occupancy sensors automatically turn lights on when occupant is detected.
 - b. Zones with occupancy and/or photocell sensors turn lights off when vacancy or sufficient daylight is detected.
 - c. Pressing the switch will turn the lights off and a short “exit timer” begins. After the timer expires, sensor scans the room to detect whether occupant is still present. If no occupancy is detected, zone returns to auto-on. If occupancy is detected, lights must be turned on via the switch.
 7. Multi-Level Operation (multiple lighting levels per manual button press)
 - a. Operating mode designed specifically for bi-level applications.
 - b. Enables the user to cycle through up to four potential on/off/dim low/dim high lighting states using only a single button.
 - c. Eliminates user confusion as to which of two buttons controls which load
 - d. Three different transition sequences are available in order to comply with energy codes or user preference).
 - e. Mode available as a setting on all devices that have single manual on/off switch.
 - f. Depending on the sequence selected, every button push steps through relay/dimming states according to below table
 - g. In addition to achieving bi-level lighting control by switching loads with relays, the ability to command dimming outputs to “step” in a sequence that achieves bi-level operation is present.

**Okaloosa County TDC – Emerald Coast Convention Center
Restroom Renovations and Meeting Room Counters**

MLO Mode		State of load after each pushbutton press			
		1st Press	2nd Press	3rd Press	4th Press
2-State (Alternating)	Load A	On	Off	Off	-
	Load B	Off	On	Off	-
2-State (Both On, A First)	Load A	On	On	Off	-
	Load B	Off	On	Off	-
2-State (Both On, B First)	Load A	Off	On	Off	-
	Load B	On	On	Off	-
3-State	Load A	On	Off	On	Off
	Load B	Off	On	On	Off
A and B On ¹	Load A	On	Off	-	-
	Load B	On	Off	-	-
A On Only ¹	Load A	On	Off	-	-
	Load B	Off	Off	-	-
A and B On & Dim High ¹	Load A	High	Off	-	-
	Load B	High	Off	-	-
Dim Low /High	Load A	Low	High	Off	-
Dim Low / High	Load A	High	Low	Off	-

NOTE 1: Modes for use only when Auto-On state of Load A & B is different than first MLO state

2.3 INDIVIDUAL DEVICE SPECIFICATIONS

A. Networked system occupancy sensors

1. Occupancy sensors shall sense the presence of human activity within the desired space and fully control the on/off function of the lights.
2. Sensors shall utilize passive infrared (PIR) technology, which detects occupant motion, to initially turn lights on from an off state, thus preventing false on conditions. Ultrasonic or Microwave based sensing technologies shall not be accepted.
3. For applications where a second method of sensing is necessary to adequately detect maintained occupancy (such as in rooms with obstructions), a sensor with an additional “dual” technology shall be used.
4. Dual technology sensors shall have one of its two technologies not require motion to detect occupancy. Acceptable dual technology includes PIR/Microphonics (also known as Passive Dual Technology or PDT) which both looks for occupant motion and listens for sounds indicating occupants. Sensors where both technologies detect motion (PIR/Ultrasonic) shall not be acceptable.
5. All sensing technologies shall be acoustically passive, meaning they do not transmit sounds waves of any frequency (for example in the Ultrasonic range), as these

**Okaloosa County TDC – Emerald Coast Convention Center
Restroom Renovations and Meeting Room Counters**

technologies have the potential for interference with other electronic devices within the space (such as electronic white board readers). Acceptable detection technologies include Passive Infrared (PIR), and/or Microphonics technology. Ultrasonic or Microwave based sensing technologies shall not be accepted.

6. Sensors shall be available with zero or one integrated dry contact switching relays, capable of switching 1 amp at 24 VAC/VDC (resistive only).
 7. Sensors shall be available with one or two occupancy “poles”, each of which provides a programmable time delay.
 8. All sensors shall have two RJ-45 ports or capable of utilizing a splitter.
 9. All sensors shall have the ability to detect when it is not receiving valid communication and blink its LED in a pattern to visually indicate of a potential wiring issue
 10. Every sensor parameter shall be available and configurable remotely from the software and locally via the device push-button.
 11. Sensors shall be able to function together with other sensors in order to provide expanded coverage areas.
 12. Sensors shall be equipped with an automatic override for 100 hour burn-in of lamps. This feature must be available at any time for lamp replacements.
 13. Wall switch sensors shall recess into single-gang switch box and fit a standard GFI opening.
 14. Wall switch sensors must meet NEC grounding requirements by providing a dedicated ground connection and grounding to mounting strap. Line and load wire connections shall be interchangeable. Sensor shall not allow current to pass to the load when sensor is in the unoccupied (Off) condition.
 15. Wall switch sensors shall have optional features for photocell/daylight override, and low temperature/high humidity operation.
 16. Wall switch sensors shall be available in four standard colors (Ivory, White, Light Almond, Gray)
 17. Wall switch sensors shall be available with optional raise/lower dimming adjustment controls.
 18. Network system shall have sensors that can be embedded into luminaire such that only the lens shows on luminaire face.
 19. Embedded sensors shall be capable of both PIR and Dual Technology occupancy detection
 20. Embedded sensors shall have an optional photocell
 21. Network system shall also have ceiling, fixture, recessed, & corner mounted sensors available.
 22. Sensors shall have optional features for photocell/daylight override, dimming control, and low temperature/high humidity operation.
- B. Networked system power (relay) packs
1. Power Packs shall incorporate one Class 1 relay, a 0-10 VDC dimming output, and contribute low voltage power to the rest of the system. Secondary Packs shall incorporate the relay and 0-10 VDC or line voltage dimming output, but shall not be required to contribute system power. Power Supplies shall provide system power only, but are not required to switch line voltage circuit.
 2. Power Packs shall accept 120 or 277 VAC (or optionally 347 VAC), be plenum rated, and provide Class 2 power to the system.

**Okaloosa County TDC – Emerald Coast Convention Center
Restroom Renovations and Meeting Room Counters**

3. Every Power Pack parameter shall be available and configurable remotely from the software and locally via the device push-button.
 4. Power Pack shall securely mount to junction location through a threaded ½ inch chase nipple or be capable of being secured within a luminaire ballast channel. Plastic clips into junction box shall not be accepted. All Class 1 wiring shall pass through chase nipple into adjacent junction box without any exposure of wire leads. Note: UL Listing under Energy Management or Industrial Control Equipment automatically meets this requirement, whereas Appliance Control Listing does not meet this safety requirement.
 5. When required by local code, Power Pack must install inside standard electrical enclosure and provide UL recognized support to junction box. All Class 1 wiring is to pass through chase nipple into adjacent junction box without any exposure of wire leads.
 6. Power Packs (Secondary) shall be available that provide up to 16 Amp switching of all lighting load types.
 7. Power Packs shall be available that provide up to 5 Amps switching of all lighting load types as well as 0-10 VDC dimming or fluorescent ballasts/LED drivers.
 8. Specific Secondary Packs shall be available that provide up to 5 Amps of switching and can dim 120/277 VAC magnetic low voltage transformers.
 9. Specific Secondary Packs shall be available that provide up to 4 Amps of switching and can dim 120 VAC electronic low voltage transformers.
 10. Specific Power/Secondary Packs shall be available that are UL924 listed for switching of Emergency Power circuits.
 11. Specific Secondary Packs shall be available that control louver/damper motors for skylights.
 12. Specific Secondary Packs shall be available that provide a pulse on/pulse off signal for purposes of controlling shade systems via relay inputs.
 13. Power (Secondary) Packs shall be available that provide up to 20 Amps switching of general purposed receptacle (plug-load) control.
- F. Networked auxiliary input / output (i/o) devices
1. Devices shall be plenum rated and be inline wired, screw mountable, or have an extended chase nipple for mounting to a ½” knockout.
 2. Devices shall have two RJ-45 ports
 3. Specific I/O devices shall have a dimming control output that can control 0-10 VDC dimmable ballasts or LED drivers by sinking up to 20 mA of current.
 4. Specific I/O devices shall have an input that reads a 0-10 VDC signal from an external device.
 5. Specific I/O devices shall have a switch input that can interface with either a maintained or momentary switch and run a switch event (toggle the lighting load) or run a local/remote control profile.
 6. Specific I/O devices shall sense state of low voltage outdoor photocells.
 7. Specific I/O devices shall sense momentary and maintained contact closures, and either toggle a connected load after a momentary contact or ramp the load high/low during a maintained contact (stopping when the contact releases).
- G. Networked system wall switches & dimmers
1. Devices shall recess into single-gang switch box and fit a standard GFI opening.

**Okaloosa County TDC – Emerald Coast Convention Center
Restroom Renovations and Meeting Room Counters**

2. All devices shall provide toggle switch control. Dimming control and low temperature/high humidity operation are available options.
3. Devices shall be available in four colors (Ivory, White, Light Almond, Gray).
4. Devices with mechanical push-buttons shall provide tactile and LED user feedback.
5. Devices with mechanical push-buttons shall be made available with custom button labeling
6. Devices with a single “on” button shall be capable of selecting all possible lighting combinations for a bi-level lighting zone such that the user confusion as to which of two buttons (as is present in multi-button scenarios) controls which load is eliminated.

H. Networked system scene controllers

1. Device shall have two, three, four, or eight buttons for selecting programmable lighting control profiles or acting as on/off switches.
2. Devices shall be available in four colors (Ivory, White, Light Almond, Gray).
3. Device shall recess into single-gang switch box and fit a standard GFI opening.
4. Devices shall provide LED user feedback.
5. Device shall be capable of reprogramming other devices in its zone so as to implement user selected lighting scene.
6. Device shall be capable of selecting a lighting profile be run by the system’s upstream Gateway so as to implement selected lighting profile across multiple zones (and not just its local zone).
7. Device shall have LEDs indicating current selection.

End of Section 260943

**Okaloosa County TDC – Emerald Coast Convention Center
Restroom Renovations and Meeting Room Counters**

Page left blank

**Okaloosa County TDC – Emerald Coast Convention Center
Restroom Renovations and Meeting Room Counters**

SECTION 262726 - WIRING DEVICES

PART 1 - GENERAL

1.1 SUMMARY

- A. This Section includes the following:
 - 1. Single and duplex receptacles, ground-fault circuit interrupters, and integral surge suppression units.
 - 2. Single- and double-pole snap switches and dimmer switches.
 - 3. Device wall plates.

1.2 SUBMITTALS

- A. Product Data: For each type of product indicated.
- B. Shop Drawings: List of legends and description of materials and process used for premarking wall plates.
- C. Samples: One for each type of device and wall plate specified, in each color specified.
- D. Field quality-control test reports.

1.3 QUALITY ASSURANCE

- A. Electrical Components, Devices, and Accessories: Listed and labeled as defined in NFPA 70, Article 100, by a testing agency acceptable to authorities having jurisdiction, and marked for intended use.
- B. Comply with NFPA 70.

PART 2 - PRODUCTS

2.1 MANUFACTURERS

Subject to compliance with requirements, manufacturers offering products that may be incorporated into the Work include, but are not limited to, the following:

- 1. Wiring Devices:
 - a. Bryant Electric, Inc./Hubbell Subsidiary.
 - b. Hubbell Incorporated; Wiring Device-Kellems.

**Okaloosa County TDC – Emerald Coast Convention Center
Restroom Renovations and Meeting Room Counters**

- c. Leviton Mfg. Company Inc.
 - d. Pass & Seymour/Legrand; Wiring Devices Div.
 - 2. Multioutlet Assemblies:
 - a. Hubbell Incorporated; Wiring Device-Kellems.
 - b. Wiremold Company (The).
- 2.2 RECEPTACLES
- A. Straight-Blade-Type Receptacles: Comply with NEMA WD 1, NEMA WD 6, DSCC W-C-596G, and UL 498.
 - B. Straight-Blade and Locking Receptacles: Heavy-Duty grade.
 - C. Straight-Blade Receptacles: Manufacturer’s top grade below Hospital grade.
 - D. GFCI Receptacles: Straight blade, feed-through type, Heavy-Duty grade, with integral NEMA WD 6, Configuration 5-20R duplex receptacle; complying with UL 498 and UL 943. Design units for installation in a 2-3/4-inch- (70-mm-) deep outlet box without an adapter.
- 2.3 PENDANT CORD/CONNECTOR DEVICES
- A. Description: Matching, locking-type plug and receptacle body connector, NEMA WD 6, Configurations L5-20P and L5-20R, Heavy-Duty grade.
 - 1. Body: Nylon with screw-open cable-gripping jaws and provision for attaching external cable grip.
 - 2. External Cable Grip: Woven wire-mesh type made of high-strength galvanized-steel wire strand, matched to cable diameter, and with attachment provision designed for corresponding connector.
- 2.4 SWITCHES
- A. Single- and Double-Pole Switches: Comply with DSCC W-C-896F and UL 20.
 - B. Snap Switches: Heavy-Duty grade, quiet type.
 - C. Combination Switch and Receptacle: Both devices in a single gang unit with plaster ears and removable tab connector that permit separate or common feed connection.
 - 1. Switch: 20 A, 120/277-V ac.
 - 2. Receptacle: NEMA WD 6, Configuration 5-20R.
 - D. Dimmer Switches: Modular, full-wave, solid-state units with integral, quiet on/off switches and audible frequency and EMI/RFI filters.

**Okaloosa County TDC – Emerald Coast Convention Center
Restroom Renovations and Meeting Room Counters**

1. Control: Continuously adjustable slider; with single-pole or three-way switching to suit connections.
2. Fluorescent Lamp Dimmer Switches: Modular; compatible with dimmer ballasts; trim potentiometer to adjust low-end dimming; dimmer-ballast combination capable of consistent dimming with low end not greater than 20 percent of full brightness.
3. LED Dimmer Switches: Modular; compatible with dimmer drivers; trim potentiometer to adjust low-end dimming; dimmer-driver combination capable of consistent dimming with low end not greater than 20 percent of full brightness.

2.5 WALL PLATES

- A. Single and combination types to match corresponding wiring devices.
 1. Plate-Securing Screws: Metal with head color to match plate finish.
 2. Material for Finished Spaces: Smooth Metal 302/304 stainless steel with satin finish.
 3. Material for Unfinished Spaces: Smooth Metal 302/304 stainless steel with satin finish except where shown surface shall be "bell" die-cast aluminum with similar plates.
 4. Material for Wet Locations: Cast aluminum with in-use lift cover, and listed and labeled for use in "wet locations."

2.6 FINISHES

- A. Color:
 1. Wiring Devices: Gray

PART 3 - EXECUTION

3.1 INSTALLATION

- A. Install devices and assemblies level, plumb, and square with building lines.
- B. Install wall dimmers to achieve indicated rating after derating for ganging.
- C. Install unshared neutral conductors on line and load side of dimmers.
- D. Arrangement of Devices: Unless otherwise indicated, mount flush, with long dimension vertical, and with grounding terminal of receptacles on top. Group adjacent switches under single, multigang wall plates.
- E. Remove wall plates and protect devices and assemblies during painting.

**Okaloosa County TDC – Emerald Coast Convention Center
Restroom Renovations and Meeting Room Counters**

3.2 IDENTIFICATION

- A. Comply with Division 26 Section "Identification for Electrical Systems."

3.3 CONNECTIONS

- A. Ground equipment according to Division 26 Section "Grounding and Bonding."
- B. Connect wiring according to Division 26 Section "Conductors and Cables."

3.4 FIELD QUALITY CONTROL

- A. Perform the following field tests and inspections and prepare test reports:
 - 1. After installing wiring devices and after electrical circuitry has been energized, test every outlet for proper polarity, ground continuity, and compliance with requirements.
 - 2. Test GFCI operation with both local and remote fault simulations according to manufacturer's written instructions.
- B. Remove malfunctioning units, replace with new units, and retest as specified above.

END OF SECTION 262726

**Okaloosa County TDC – Emerald Coast Convention Center
Restroom Renovations and Meeting Room Counters**

SECTION 265100 - INTERIOR LIGHTING

PART 1 - GENERAL

1.1 RELATED DOCUMENTS

- A. Drawings and general provisions of the Contract, including General and Supplementary Conditions and Division 1 Specification Sections, apply to this Section.

1.2 SUMMARY

- A. This Section includes the following:
 - 1. Interior lighting fixtures, lamps, and ballasts.
 - 2. Emergency lighting units.
 - 3. Exit signs.
 - 4. Lighting fixture supports.
- B. Related Sections include the following:
 - 1. Division 26 Section "Wiring Devices" for manual wall-box.
 - 2. Division 26 Section "Lighting Controls and Devices" for automatic control of lighting, including time switches, photoelectric relays, occupancy sensors, and multipole lighting relays and contactors.

1.3 DEFINITIONS

- A. BF: Ballast factor.
- B. CRI: Color-rendering index.
- C. CU: Coefficient of utilization.
- D. HID: High-intensity discharge.
- E. LER: Luminaire efficacy rating.
- F. Luminaire: Complete lighting fixture, including ballast/driver housing if provided.
- G. RCR: Room cavity ratio.
- H. SSL: Solid State Lighting (LED)

**Okaloosa County TDC – Emerald Coast Convention Center
Restroom Renovations and Meeting Room Counters**

- I. BUG Rating: Backlight, Uplight, Glare Rating.

1.4 SUBMITTALS

- A. Product Data: For each type of lighting fixture, arranged in order of fixture designation. Include data on features, accessories, finishes, and the following:
1. Physical description of lighting fixture including dimensions.
 2. Emergency lighting units including battery and charger.
 3. Ballast.
 4. Energy-efficiency data.
 5. Life, output, and energy-efficiency data for lamps.
 6. Photometric data, in IESNA format, based on laboratory tests of each lighting fixture type, outfitted with lamps, ballasts, drivers, and accessories identical to those indicated for the lighting fixture as applied in this Project.
 - a. For indicated fixtures, photometric data shall be certified by a qualified independent testing agency. Photometric data for remaining fixtures shall be certified by the manufacturer.
 - b. Photometric data shall be certified by a manufacturer's laboratory with a current accreditation under the National Voluntary Laboratory Accreditation Program (NVLAP) for Energy Efficient Lighting Products.
- B. Shop Drawings: Show details of nonstandard or custom lighting fixtures. Indicate dimensions, weights, methods of field assembly, components, features, and accessories.
- C. Wiring Diagrams: Power and control wiring.
- D. Coordination Drawings: Reflected ceiling plan(s) and other details, drawn to scale, on which the following items are shown and coordinated with each other, based on input from installers of the items involved:
1. Lighting fixtures.
 2. Suspended ceiling components.
 3. Structural members to which suspension systems for lighting fixtures will be attached.
 4. Other items in finished ceiling including the following:
 - a. Air outlets and inlets.
 - b. Speakers.
 - c. Sprinklers.
 - d. Smoke and fire detectors.
 - e. Occupancy sensors.
 - f. Access panels.
 - g. Perimeter moldings.
 5. Product Certificates: For each type of ballast for bi-level and dimmer-controlled fixtures, signed by product manufacturer.
 6. Qualification Data: For agencies providing photometric data for lighting fixtures.
 7. Field quality-control test reports.

**Okaloosa County TDC – Emerald Coast Convention Center
Restroom Renovations and Meeting Room Counters**

8. Operation and Maintenance Data: For lighting equipment and fixtures to include in emergency, operation, and maintenance manuals.
9. Warranties: Special warranties specified in this Section.

1.5 QUALITY ASSURANCE

- A. Luminaire Photometric Data Testing Laboratory Qualifications: Provided by manufacturers' laboratories that are accredited under the National Volunteer Laboratory Accreditation Program for Energy Efficient Lighting Products.
- B. Luminaire Photometric Data Testing Laboratory Qualifications: Provided by an independent agency, with the experience and capability to conduct the testing indicated, that is an NRTL as defined by OSHA in 29 CFR 1910.7.
- C. Electrical Components, Devices, and Accessories: Listed and labeled as defined in NFPA 70, Article 100, by a testing agency acceptable to authorities having jurisdiction, and marked for intended use.
- D. Comply with NFPA 70.
- E. FMG Compliance: Lighting fixtures for hazardous locations shall be listed and labeled for indicated class and division of hazard by FMG.

1.6 COORDINATION

- A. Coordinate layout and installation of lighting fixtures and suspension system with other construction that penetrates ceilings or is supported by them, including HVAC equipment, fire-suppression system, and partition assemblies.

1.7 WARRANTY

- A. Special Warranty for Emergency Lighting Batteries:
 1. Warranty Period for Self-Powered Exit Sign Batteries: 5 years from date of Substantial Completion. Full warranty shall apply for full 5 years, no prorated warranties are permitted.
- B. Special Warranty for Ballasts: Manufacturer's standard form in which ballast manufacturer agrees to repair or replace ballasts that fail in materials or workmanship within specified warranty period.
 1. Warranty Period for Electronic Ballasts: 5 years from date of Substantial Completion.
 2. Warranty Period for Electromagnetic Ballasts: 3 years from date of Substantial Completion.

**Okaloosa County TDC – Emerald Coast Convention Center
Restroom Renovations and Meeting Room Counters**

3. Warranty Period: Two year(s) from date of Substantial Completion.

1.8 EXTRA MATERIALS

- A. Furnish extra materials described below that match products installed and that are packaged with protective covering for storage and identified with labels describing contents.
 1. Lamps: 10 for every 100 of each type and rating installed. Furnish at least one of each type.
 2. Plastic Diffusers and Lenses: 1 for every 100 of each type and rating installed. Furnish at least one of each type.
 3. Battery and Charger Data: One for each emergency lighting unit.
 4. Ballasts: 1 for every 100 of each type and rating installed. Furnish at least one of each type.
 5. Globes and Guards: 1 for every 20 of each type and rating installed. Furnish at least one of each type.

PART 2 - PRODUCTS

2.1 MANUFACTURERS

- A. In other Part 2 articles where titles below introduce lists, the following requirements apply to product selection:
- B. In Interior Lighting Fixture Schedule where titles below are column or row headings that introduce lists, the following requirements apply to product selection:
 1. Available Manufacturers: Subject to compliance with requirements, manufacturers offering products that may be incorporated into the Work include, but are not limited to, manufacturers specified.
 2. Manufacturers: Subject to compliance with requirements, provide products by one of the manufacturers specified.
 3. Basis-of-Design Product: The design for each lighting fixture is based on the product named. Subject to compliance with requirements, provide either the named product or a comparable product by one of the other manufacturers specified.

2.2 LIGHTING FIXTURES AND COMPONENTS, GENERAL REQUIREMENTS

- A. Recessed Fixtures: Comply with NEMA LE 4 for ceiling compatibility for recessed fixtures.
- B. LED Fixtures: Comply with UL 8750. Test according to Illuminating Engineering Society of North America (IESNA) LM-80 standards.
- C. Metal Parts: Free of burrs and sharp corners and edges.

**Okaloosa County TDC – Emerald Coast Convention Center
Restroom Renovations and Meeting Room Counters**

- D. Sheet Metal Components: Steel, unless otherwise indicated. Form and support to prevent warping and sagging.
- E. Doors, Frames, and Other Internal Access: Smooth operating, free of light leakage under operating conditions, and designed to permit relamping without use of tools. Designed to prevent doors, frames, lenses, diffusers, and other components from falling accidentally during relamping and when secured in operating position.
- F. Reflecting surfaces shall have minimum reflectance as follows, unless otherwise indicated:
 - 1. White Surfaces: 85 percent.
 - 2. Specular Surfaces: 83 percent.
 - 3. Diffusing Specular Surfaces: 75 percent.
 - 4. Laminated Silver Metalized Film: 90 percent.
- G. Plastic Diffusers, Covers, and Globes:
 - 1. Acrylic Lighting Diffusers: 100 percent virgin acrylic plastic. High resistance to yellowing and other changes due to aging, exposure to heat, and UV radiation.
 - a. Lens Thickness: At least 0.125 inch minimum unless different thickness is indicated.
 - b. UV stabilized.
- H. Electromagnetic-Interference Filters: Factory installed to suppress conducted electromagnetic-interference as required by MIL-STD-461E. Fabricate lighting fixtures with one filter on each ballast indicated to require a filter.

2.3 LED TROFFERS

- A. Description: Led lighting fixtures shall have long life replaceable LEDs (where applicable) coupled with high-efficiency drivers, provide superior quality and quality of illumination for extended service life. Fixture shall be rated to deliver specified performance for 50,000 hours.
- B. Fixtures noted to be dimmable shall have 0-10-volt control. COORDINATE with dimming system.
- C. Fixtures shall provide (degree) K color temperatures as indicated on drawings.
- D. Fixtures shall have a minimum of 5-year warranty
- E. LM-79-08, IESNA Approved Method for the Electrical and Photometric Measurements of Solid-State Lighting Products

**Okaloosa County TDC – Emerald Coast Convention Center
Restroom Renovations and Meeting Room Counters**

- F. LM-80-08, IESNA Approved Method for Measuring Lumen Maintenance of LED Light Sources

2.4 EMERGENCY LIGHTING UNITS

- A. Description: Self-contained units complying with UL 924.
1. Battery: Sealed, maintenance-free, lead-acid type.
 2. Charger: Fully automatic, solid-state type with sealed transfer relay.
 3. Operation: Relay automatically turns lamp on when power supply circuit voltage drops to 80 percent of nominal voltage or below. Lamp automatically disconnects from battery when voltage approaches deep-discharge level. When normal voltage is restored, relay disconnects lamps from battery, and battery is automatically recharged and floated on charger.
 4. Test Push Button: Push-to-test type, in unit housing, simulates loss of normal power and demonstrates unit operability.
 5. LED Indicator Light: Indicates normal power on. Normal glow indicates trickle charge; bright glow indicates charging at end of discharge cycle.
 6. Wire Guard: Heavy-chrome-plated wire guard protects lamp heads or fixtures.
 7. Integral Time-Delay Relay: Holds unit on for fixed interval of 15 minutes when power is restored after an outage.
 8. Remote Test: Switch in hand-held remote device aimed in direction of tested unit initiates coded infrared signal. Signal reception by factory-installed infrared receiver in tested unit triggers simulation of loss of its normal power supply, providing visual confirmation of either proper or failed emergency response.
 9. Integral Self-Test: Factory-installed electronic device automatically initiates code-required test of unit emergency operation at required intervals. Test failure is annunciated by an integral audible alarm and flashing red LED.

2.5 EXIT SIGNS

- A. Description: Comply with UL 924; for sign colors, visibility, luminance, and lettering size, comply with authorities having jurisdiction.

2.6 LIGHTING FIXTURE SUPPORT COMPONENTS

- A. Comply with Division 26 Section "Electrical Supports" for channel- and angle-iron supports and nonmetallic channel and angle supports.
- B. Single-Stem Hangers: 1/2-inch steel tubing with swivel ball fittings and ceiling canopy. Finish same as fixture.
- C. Twin-Stem Hangers: Two, 1/2-inch steel tubes with single canopy designed to mount a single fixture. Finish same as fixture.

**Okaloosa County TDC – Emerald Coast Convention Center
Restroom Renovations and Meeting Room Counters**

- D. Wires: ASTM A 641/A 641M, Class 3, soft temper, zinc-coated steel, 12 gage.
- E. Wires for Humid Spaces: ASTM A 580/A 580M, Composition 302 or 304, annealed stainless steel, 12 gage.
- F. Rod Hangers: 3/16-inch minimum diameter, cadmium-plated, threaded steel rod.
- G. Hook Hangers: Integrated assembly matched to fixture and line voltage and equipped with threaded attachment, cord, and locking-type plug.

2.7 REQUIREMENTS FOR INDIVIDUAL LIGHTING FIXTURES

- A. Comply with requirements of Lighting Fixture Schedule on electrical drawings.

PART 3 - EXECUTION

3.1 INSTALLATION

- A. Lighting fixtures: Set level, plumb, and square with ceilings and walls. Install lamps in each fixture.
- B. Support for Lighting Fixtures in or on Grid-Type Suspended Ceilings: Use grid as a support element.
 - 1. Install a minimum of four ceiling support system rods or wires for each fixture. Locate not more than 6 inches from lighting fixture corners.
 - 2. Support Clips: Fasten to lighting fixtures and to ceiling grid members at or near each fixture corner with clips that are UL listed for the application.
 - 3. Fixtures of Sizes Less Than Ceiling Grid: Install as indicated on reflected ceiling plans or center in acoustical panel, and support fixtures independently with at least two 3/4-inch metal channels spanning and secured to ceiling tees.
 - 4. Install at least one independent support rod or wire from structure to a tab on lighting fixture. Wire or rod shall have breaking strength of the weight of fixture at a safety factor of 3.
- C. Suspended Lighting Fixture Support:
 - 1. Pendants and Rods: Where longer than 48 inches, brace to limit swinging.
 - 2. Stem-Mounted, Single-Unit Fixtures: Suspend with twin-stem hangers.
 - 3. Continuous Rows: Use tubing or stem for wiring at one point and tubing or rod for suspension for each unit length of fixture chassis, including one at each end.

**Okaloosa County TDC – Emerald Coast Convention Center
Restroom Renovations and Meeting Room Counters**

- D. Adjust aimable lighting fixtures to provide required light intensities.
- E. Connect wiring according to Division 26 Section "Conductors and Cables."

3.2 FIELD QUALITY CONTROL

- A. Test for Emergency Lighting: Interrupt power supply to demonstrate proper operation. Verify transfer from normal power to battery and retransfer to normal.
- B. Prepare a written report of tests, inspections, observations, and verifications indicating and interpreting results. If adjustments are made to lighting system, retest to demonstrate compliance with standards.

END OF SECTION 265100

BID DOCUMENTS EMERALD COAST CONVENTION CENTER RESTROOM RENOVATIONS & MEETING ROOM COUNTERS

1250 MIRACLE STRIP PKWY SE
 FORT WALTON BEACH, FL 32548



ARTISTIC RENDERINGS, AERIAL IMAGES AND AXONOMETRICS ARE PROVIDED FOR PROJECT ORIENTATION ONLY. RENDERINGS, AERIAL IMAGES AND AXONOMETRICS ARE NOT TO SCALE AND DO NOT NECESSARILY ACCURATELY REFLECT ALL PROVISIONS OF THE CONTRACT DOCUMENTS.

PROJECT SCOPE

FULL PROJECT SCOPE INCLUDED IN THE SPECIFICATIONS.

STANDARD SYMBOLS

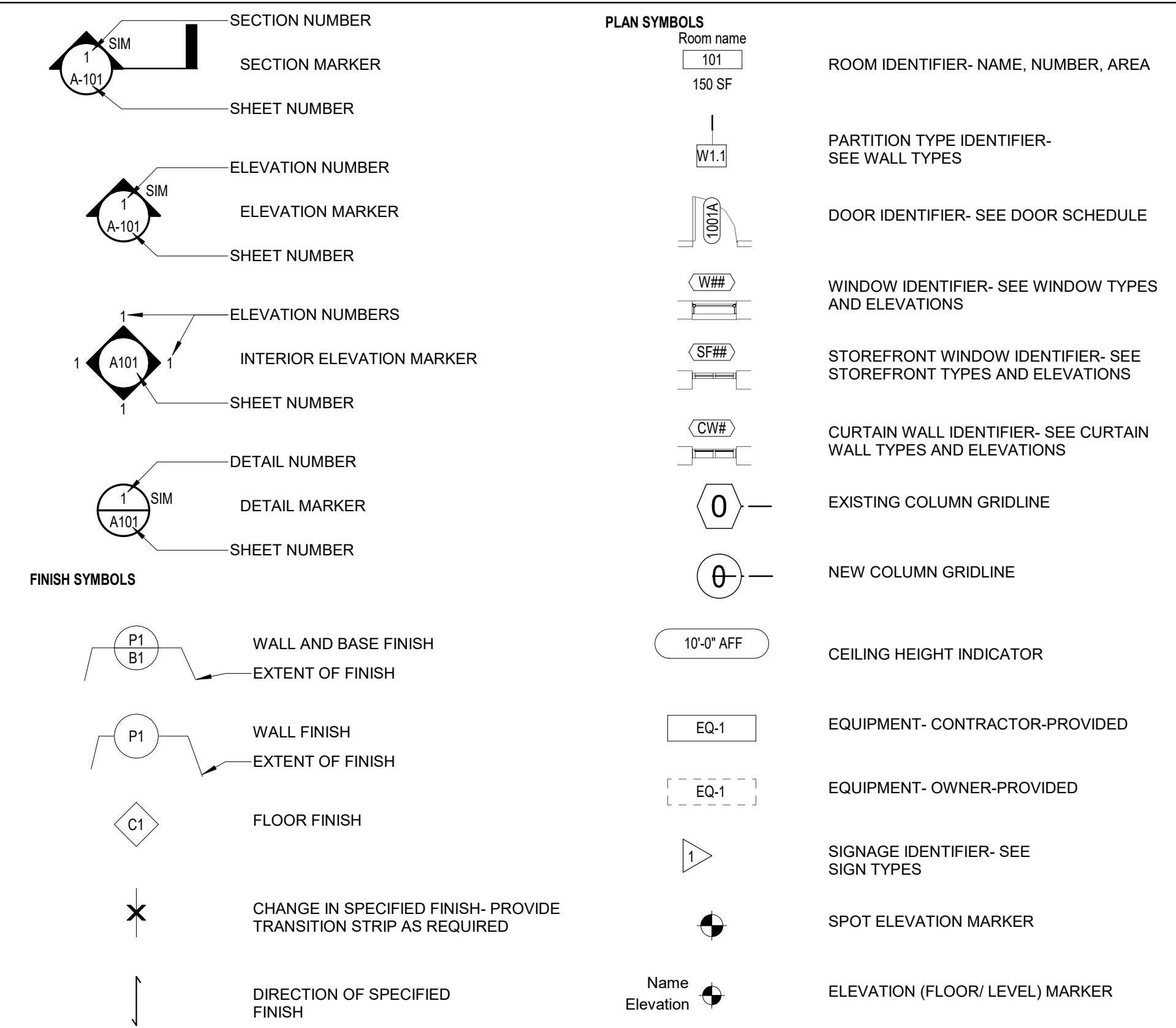

STANDARD ABBREVIATIONS

AC	AIR CONDITIONED	FT	FOOT, FEET	PLYWD	PLYWOOD
AD	AREA DRAIN	FTG	FOOTING	PNL	PANEL
AF	ABOVE FINISHED FLOOR	GA	GAUGE	PRES.	PRESSURE
AHJ	AIR HANDLING UNIT	GAL	GALLON	PSF	POUNDS/SQUARE FOOT
ALT	ALTERNATE	GALV	GALVANIZED	PSI	POUNDS/SQUARE INCH
ALUM	ALUMINUM	GEJ	GUTTER EXPANSION JOINT	PSIG	POUNDS/SQUARE INCH-GAGE
AMP, A	AMPERES	GFE	GOVERNMENT FURNISHED EQUIP	PT	POINT
AO	ACCESS OPENING	GL	GLASS	PTD	PAINTED
APPROX	APPROXIMATELY	GMS	GALVANIZED METAL STUD	QTR	QUARTER
ARCH	ARCHITECTURAL	GND	GROUND	QUAN	QUANTITY
A.T.	ASPHALT TILE	GOVT	GOVERNMENT	R	RISER
ATC	ACOUSTIC TILE CEILING	GPH	GALLONS/HOUR	RA	RETURN AIR
BAL	BALANCE	GPM	GALLONS/MINUTE	RAD	RADIUS
BD	BOARD	GR	GRILLE	RAL	RIVERBANK ACOUSTICAL LABORATORIES
BLDG	BUILDING	GWB	GYPSUM WALLBOARD	RD	ROUND
BLK	BLANK	H	HIGH	RGR	REGISTER
BM	BEAM	HB	HOSE BIB	REF	REINFORCING
BOT	BOTTOM	HC	HOLLOW CORE	REQ	REQUIRED
BRC	BEARING	HT	HEIGHT	RET	RETURN
BTUH	BRITISH THERMO UNIT/HOUR	HORIZ	HORIZONTAL	RG	RETURN GRILLE
CAB	CABINET	HM	HOLLOW METAL	RM	ROOM
CAP	CAPACITY	HP	HORSEPOWER	RPM	REVOLUTIONS/MINUTE
C/B	CIRCUIT BREAKER	HR	HOUR	S	SUPPLY
CD	CEILING DIFFUSER	HTG	HEATING	SA	SUPPLY AIR
CEM	CEMENT	HTR	HEATER	SCH	SCHEDULE
CER	CERAMIC	H&V	HEATING AND VENTILATING	SCHED	SCHEDULE
CFM	CUBIC FEET/MINUTE	HV	HARDWARE	SECT	SECTION
CIRCT	CIRCUIT	HYD	HYDRANT	SERV	SERVICE
CL	CENTERLINE	IC	INSIDE DIAMETER	SHT	SHEET
CEIL	CEILING	IE	INVERT ELEVATION	SJ	SAWED JOINT
CEG	CORNER GUARD	IC	IMPACT INSULATION CLASS	SPEC	SPECIFICATIONS
CL	CLOSET	IN	INCHES	SO FT	SQUARE FEET
CLG	CEILING	INCAND	INCANDESCENT	ST	STEEL
CLR	CLEAR	INSUL	INSULATION	STC	SOUND TRANSMISSION CLASS
CMU	CONCRETE MASONRY UNIT	INT	INTERIOR	STOR	STORAGE
CO	CLEANOUT	JB	JUNCTION BOX	STRUC	STRUCTURAL
COL	COLUMN	JCT	JUNCTION	SUSP	SUSPENDED
CONC	CONCRETE	JT	JOINT	SW	SWITCH
COND	CONDENSATE	KB	KNOX BOX	T	TOILET
CONN	CONNECTION	KVA	KILOVOLT-AMPERE	TEL	TELEPHONE
CONST	CONSTRUCTION	LB, #	POUND	TEMP	TEMPERATURE
CONT	CONTINUOUS	LG	LONG	THK	THICKNESS
CONTR JT	CONTRACTION JOINT	LLV	LONG LEG VERTICAL	THD	THRESHOLD
CSC	COLOR SYMBOL CODE	LP	LIGHTING PANEL	TOC	TOP OF CONCRETE
CT	CERAMIC TILE	LTG	LIGHTING	TOP	TOP OF FOOTING
CTB	CERAMIC TILE BASE	M	MOTOR	TOIL	TOILET
CTOC	CENTER TO CENTER	MAINT	MAINTENANCE	TYP	TYPICAL
DET	DETAIL	MAX	MAXIMUM	UL	UNDERWRITER LABORATORIES
DIA	DIAMETER	MDP	MAIN DISTRIBUTION PANEL	V	VOLT
DIFF	DIFFUSER	MECH	MECHANICAL	VAT	VINYL ASBESTOS TILE
DIM	DIMENSION	MTL	METAL	VENT	VENTILATION
DISC	DISCONNECT	MIN	MINIMUM	VERT	VERTICAL
DJ	DUMMY JOINT	MISC	MISCELLANEOUS	VTR	VENT THROUGH ROOF
DN	DOWN	MO	MASONRY OPENING	W	WATT
DR	DRAIN	MT	METAL THRESHOLD	W/	WITH
DS	DOWNSPOUT	MTD	MOUNTED	WC	WAINSCOTING
DWG(S)	DRAWING(S)	MTG	MOUNTING	WD	WOOD
EA	EACH	MV	MECHANICAL VENTILATION	W.D.	WINDOW DIMENSION
EF	EACH FACE	MGT	MATTE GLAZE TILE	WF	WIDE FLANGE
EJC	EXPANSION JOINT COVER	NA	NOT APPLICABLE	WG	WEATHER GAGE
ELEC	ELECTRIC	NIC	NOT IN CONTRACT	WP	WEATHERPROOF
EQUIP	EQUIPMENT	NO	NUMBER	WTR	WATER
EW	EACH WAY	NRC	NOISE REDUCTION COEFFICIENT	WTF	WELDED WIRE FABRIC
EWC	ELECTRIC WATER COOLER	OA	OUTDOOR AIR	XC	EXPANSION CONTROL
EXH	EXHAUST	OC	ON CENTER		
EXP JT	EXPANSION JOINT	OD	OVERLOAD		
EXT	EXTERIOR	OPNG	OPENING		
EXIST	EXISTING	OPP	OPPOSITE		
FA	FIRE ALARM	OSD	OPEN SIGHT DRAIN		
FC	FLEXIBLE CONNECTION	P	PAPER		
FD	FLOOR DRAIN	PART.	PARTITION		
FE	FIRE EXTINGUISHER AND BRACKET	PER	PERIMETER		
FEC	FIRE EXTINGUISHER AND CABINET	PJF	PREFORMED JOINT FILLER		
FIN	FINISH	PL	PLATE		
FL	FLOOR	PLBG	PLUMBING		

LOCATION MAP

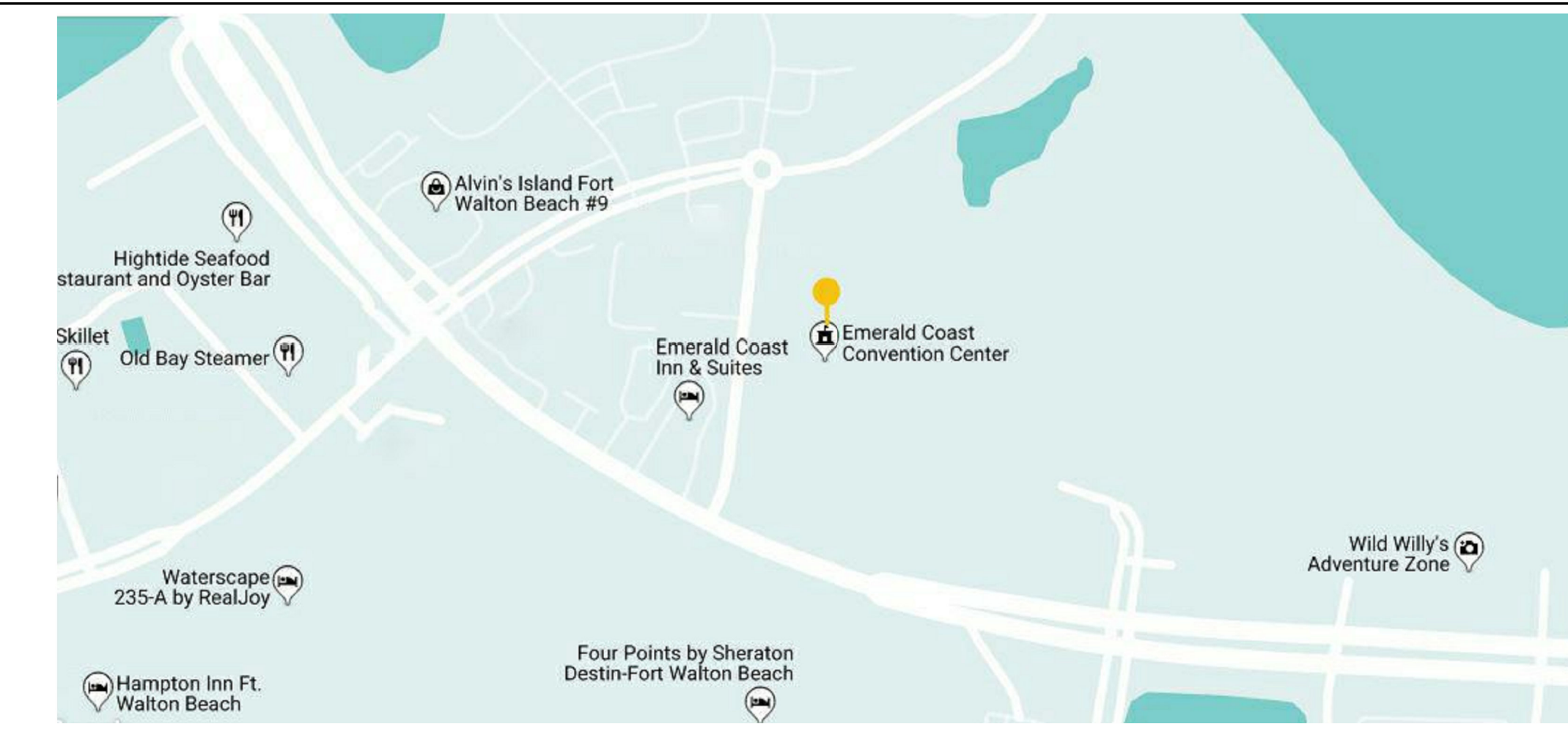

OWNERSHIP OF SERVICE
 ALL REPORTS, PLANS, SPECIFICATIONS, COMPUTER FILES, FIELD DATA, NOTES AND OTHER DOCUMENTS AND INSTRUMENTS PREPARED BY THE CONSULTANT AS AN INSTRUMENT OF SERVICE SHALL REMAIN THE PROPERTY OF THE CONSULTANT. THE CONSULTANT SHALL RETAIN ALL COMMON LAW, STATUTORY AND OTHER RESERVED RIGHTS, INCLUDING THE COPYRIGHT THERE TO.

FURTHER TO FLORIDA STATUTES, SECTION 550.003, AN INDIVIDUAL EMPLOYEE OR AGENT MAY NOT BE HELD INDIVIDUALLY LIABLE FOR NEGLIGENCE.

BID DOCUMENTS

EMERALD COAST CONVENTION CENTER
 RESTROOM RENOVATIONS & MEETING ROOM
 COUNTERS
 TASK ORDER NO. 5 - C-18-2638-TDD
 1250 MIRACLE STRIP PKWY SE
 FORT WALTON BEACH, FL 32548

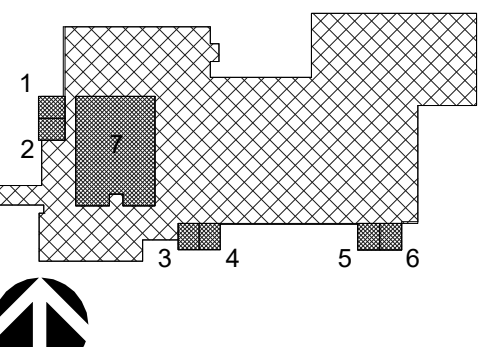

REVISIONS:

No.	Description	Date

COVER SHEET

Project number	17057.5
Dated	JANUARY 2019
PIC	Approver
PM	Designer

G000
 Scale As indicated

PROJECT TEAM	
ARCHITECTURE:	DAC ARCHITECTS 1223 AIRPORT RD DESTIN, FL 32541 CONTACTS: CHARLIE CLARY, ALEX GACIC 850.537.3152
MECHANICAL/PLUMBING:	WATFORD ENGINEERING, INC. 4471 CLINTON ST. MARIANNA, FL 32446 CONTACT NAME: DAVID WATFORD, P.E. PHONE # 850-526-3447
ELECTRICAL:	HUMBER-GARICK 142 EGLIN PARKWAY, S.E. FORT WALTON BEACH, FL 32548 CONTACT NAME: DAN WHITE, P.E. PHONE # 850-243-6723

INDEX OF DRAWINGS	
SHEET NUMBER	SHEET TITLE
ARCHITECTURAL	
D101.1	DEMO PLAN - OVERALL
D101.2	ENLARGED DEMO RCP
ARCHITECTURAL	
A101	OVERALL FIRST FLOOR PLAN
A102	OVERALL ROOF PLAN
A400	INTERIOR FINISH LEGEND
A401	ENLARGED PLAN - RESTROOM 1
A402	ENLARGED PLAN - RESTROOM 2
A403	ENLARGED PLAN - RESTROOM 3
A404	ENLARGED PLAN - RESTROOM 4
A405	ENLARGED PLAN - RESTROOM 5
A406	ENLARGED PLAN - RESTROOM 6
A407	ENLARGED - CONFERENCE ROOMS
A600	CASEWORK AND VANITY DETAILS
PLUMBING	
P 001	PLUMBING LEGEND, SCHEDULE, DETAIL, & NOTES
P 002	PLUMBING SPECIFICATIONS
P 101	PLUMBING OVERALL PLAN
P 201	PLUMBING ENLARGED PLANS

INDEX OF DRAWINGS	
SHEET NUMBER	SHEET TITLE
FIRE PROTECTION	
FP 101	FIRE PROTECTION OVERALL PLAN
FP 201	FIRE PROTECTION ENLARGED PLANS
MECHANICAL	
M 001	MECHANICAL LEGEND, SCHEDULE, DETAIL, & NOTES
M 101	MECHANICAL OVERALL PLAN
M 201	ENLARGED MECHANICAL PLANS
M 301	MECHANICAL DETAILS
M 302	MECHANICAL DETAILS
ELECTRICAL	
E 100	ELECTRICAL LEGEND & NOTES
E 200	ELECTRICAL NEW WORK RESTROOMS
E 300	PARTIAL PLAN ELECTRICAL VIEW WORK MEETING ROOMS
ED 200	ELECTRICAL DEMOLITION RESTROOMS

GENERAL NOTES:

- THE LIMIT OF WORK IN THESE CONTRACT DOCUMENTS IS 5'-0" FROM THE BUILDING PERIMETER OR UNLESS OTHERWISE SPECIFICALLY NOTED.
- CONTRACTOR SHALL PREPARE EXISTING SURFACES TO RECEIVE NEW WORK AND/OR SHALL PATCH AND REPAIR SURFACES DAMAGED DURING REMOVAL OR INSTALLATION OF THE WORK INDICATED. DAMAGED SURFACES SHALL BE REPAIRED TO MATCH THE EXISTING ADJACENT SURFACES. WHERE REMOVAL OF EXISTING ITEMS CREATES VOIDS OR DEPRESSION IN EXISTING CONSTRUCTION CONTRACTOR SHALL PATCH AND REPAIR TO BE FLUSH WITH EXISTING.
- DAG ARCHITECTS DID NOT PERFORM A COMPREHENSIVE FIELD SURVEY AND IS NOT TO BE HELD ACCOUNTABLE FOR INACCURATE DIMENSIONS OR HIDDEN CONDITIONS. ALL DIMENSIONS OF EXISTING CONDITIONS ARE TO FINISHED SURFACES, WERE HAND MEASURED AND MAY HAVE BEEN ROUNDED OFF TO THE VALUES SHOWN ON THE DRAWINGS PROVIDED. THE REPRESENTATION OF HIDDEN CONDITIONS IS BASED UPON DAG ARCHITECTS KNOWLEDGE OF TYPICAL CONSTRUCTION PRACTICES AND SHOULD BE VERIFIED BY THE CONTRACTOR.
- THE CONTRACTOR IS TO FIELD VERIFY ALL EXISTING CONDITIONS TO INCLUDE DIMENSIONS, ELEVATIONS, COMPONENTS AND ASSEMBLIES BEFORE BIDDING, PURCHASE, FABRICATION, ASSEMBLY OR INSTALLATION. CONTRACT ADJUSTMENTS DUE TO FAILURE TO VERIFY NON-HIDDEN CONDITIONS WILL NOT BE ACCEPTED.
- CONTRACTOR SHALL MAINTAIN FREE AND UNOBSTRUCTED ACCESS TO AND EGRESS FROM THE AREA OF WORK.
- CONTRACTOR SHALL CLEAN AND REMOVE DEBRIS ON A DAILY BASIS.
- GENERAL CONTRACTOR SHALL COORDINATE ALL PORTIONS OF THE WORK AND MAINTAIN A QUALIFIED SUPERINTENDENT FULL-TIME WHEN WORK IS TO BE PERFORMED ON SITE AT ALL TIMES, NO EXCEPTIONS.
- THE LOCATIONS OF KNOWN UNDERGROUND UTILITIES ARE SHOWN IN AN APPROXIMATE WAY ONLY AND HAVE NOT BEEN INDEPENDENTLY VERIFIED BY THE OWNER OR ITS REPRESENTATIVE. THE CONTRACTOR SHALL DETERMINE THE EXACT LOCATION OF ALL EXISTING UTILITIES BEFORE COMMENCING WORK, AND AGREES TO BE FULLY RESPONSIBLE FOR ANY AND ALL DAMAGES WHICH MIGHT BE OCCASIONED BY THE CONTRACTOR'S FAILURE TO EXACTLY LOCATE AND PRESERVE ANY AND ALL UNDERGROUND UTILITIES

- GENERAL CONTRACTOR SHALL MAINTAIN RECORD DRAWINGS ON SITE DURING CONSTRUCTION THAT SHOW AS-BUILT CONDITIONS OF ALL WORK INCLUDING PIPING, ELECTRICAL RUNS, DIMENSIONS, DISCOVERED ITEMS DUE TO DEMOLITION, ETC. THESE RECORD DRAWINGS ARE TO BE PROVIDED TO THE ARCHITECT PRIOR TO SUBSTANTIAL COMPLETION.
- ANY DEVIATIONS IN THE WORK SHALL BE COORDINATED BETWEEN OWNER AND ARCHITECT PRIOR TO WORK PERFORMED. IF IT DOES NOT MEET APPROVAL OF OWNER, THE CONTRACTOR SHALL BEAR ALL COSTS ASSOCIATED IN CORRECTING THE WORK AT NO EXPENSE TO THE OWNER.
- CONTRACTOR SHALL PROVIDE ALL LABOR, TOOLS & EQUIPMENT NECESSARY WHETHER INDICATED OR REQUIRED TO PROVIDE THE OWNER WITH A COMPLETE PROJECT READY FOR USE.
- CONTRACTORS SHALL FOLLOW ALL FEDERAL, STATE AND LOCAL CODES AND LAWS IN PERFORMANCE OF THE WORK. ALL CONTRACTORS SHALL PROVIDE WRITTEN PROOF OF INSURANCE PRIOR TO NOTICE TO PROCEED.
- GENERAL CONTRACTOR SHALL WARRANTY ALL PORTIONS OF THE WORK ONE YEAR FROM THE DATE OF SUBSTANTIAL COMPLETION. GENERAL CONTRACTOR SHALL ACQUIRE ALL WARRANTIES FROM ALL TRADES AND SUBMIT FOR SUBSTANTIAL COMPLETION.
- ALL DIMENSIONS FOR NEW CONSTRUCTION ARE TO FACE OF STUD, TO FACE OF CMU AND TO CENTER LINE OF COLUMN.
- GENERAL CONTRACTOR SHALL COORDINATE SITE ACCESS AND SCHEDULE WITH THE OWNER IN ORDER TO MINIMIZE DISRUPTION OF THE OWNER'S ACCESS TO THE FACILITIES.
- PROJECT KEYNOTES ARE SHEET SPECIFIC. EACH KEYNOTE IS FOR THAT PARTICULAR SHEET ONLY. IF SAME KEYNOTES ARE USED ON DIFFERENT SHEETS, THIS IS FOR EASE OF COMMUNICATION, BUT DOES NOT PRECLUDE OR OVERRIDE EACH INDIVIDUAL SHEET'S KEYNOTES.
- CONTRACTOR SHALL COORDINATE ALL PORTIONS OF THE WORK

DEMOLITION NOTES:

- CONTRACTOR SHALL LIMIT REMOVAL AND DEMOLITION WORK TO THAT SPECIFICALLY REQUIRED FOR THE INSTALLATION OF NEW WORK. CONTRACTOR SHALL BE RESPONSIBLE FOR VERIFYING DEMOLITION ANY DAMAGE TO THE EXISTING SITE SHALL BE FULLY REPAIRED AND RESTORED TO MATCH THE ORIGINAL CONSTRUCTION AT NO COST TO THE OWNER. COORDINATE WORK WITH ALL DISCIPLINES INVOLVED PRIOR TO COMMENCEMENT.
- CONTRACTOR SHALL REPAIR ALL VOIDS, OPENINGS OR HOLES IN EXISTING SUBSTRATES THAT RESULT FROM THE REMOVAL OF EXISTING EQUIPMENT, FIXTURES, DEVICES, PIPING AND SIMILAR ITEMS. CONTRACTOR SHALL USE SIMILAR MATERIALS, EQUAL IN QUALITY TO THE AREAS BEING REPAIRED.
- WHERE CONSTRUCTION AROUND EXISTING WALLS HAS BEEN DISTURBED EITHER PARTIAL OR COMPLETE, THE CONTRACTOR SHALL BE RESPONSIBLE FOR RECONSTRUCTING A COVERING TO MATCH THE EXISTING ADJACENT WALL SURFACE, USING SIMILAR MATERIALS EQUAL IN QUALITY TO THE AREAS BEING REPAIRED.
- MECHANICAL AND ELECTRICAL RUNS DISCOVERED WITHIN A DEMOLISHED WALL, YET NOT INDICATED ON THE CONTRACT DOCUMENTS AS TO THEIR REROUTING, GAPPING, ETC., SHALL BE IDENTIFIED IN NATURE AND EXTENT OF RUN BY THE CONTRACTOR AND THEN THE OWNER'S REPRESENTATIVE SHALL BE CONTACTED FOR FURTHER CLARIFICATION.
- CONTRACTOR SHALL REPAIR ALL VOIDS, OPENINGS OR HOLES IN EXISTING SUBSTRATES AND/OR EXISTING EXTERIOR ENVELOPE THAT RESULT FROM THE REMOVAL OF EXISTING EQUIPMENT, FIXTURES, DEVICES, PIPING AND SIMILAR ITEMS. CONTRACTOR SHALL USE SIMILAR MATERIALS, EQUAL IN QUALITY TO THE AREAS BEING REPAIRED.
- CONTRACTOR SHALL BRACE ALL WALLS, ROOFS, AND FLOORING TO PREVENT COLLAPSE.
- THE OWNER IS TO HAVE FIRST RIGHT OF REFUSAL ON ALL MATERIALS, ASSEMBLIES, EQUIPMENT, FIXTURES, APPURTENANCES, ETC. THAT ARE REMOVED FROM THE PROJECT SITE. CONTRACTOR IS TO EXERCISE ALL DUE CARE TO REMOVE ITEMS DESIGNATED BY OWNER IN A MANNER TO MINIMIZE DAMAGE TO ITEMS.
- CONTRACTOR IS TO NOTIFY ARCHITECT IMMEDIATELY OF ANY DISCREPANCIES BETWEEN THESE DRAWINGS AND ACTUAL EXISTING CONDITIONS.
- GC TO NOTIFY ARCHITECT UPON COMPLETION OF DEMOLITION, BEFORE BEGINNING RENOVATION, FOR OBSERVATION OF PREVIOUSLY HIDDEN CONDITIONS.
- ANY EXISTING PENETRATIONS OF THE BUILDING WEATHER ENVELOPE THAT ARE TO BE ABANDONED ARE TO BE CAULKED, SEALED, FLASHED, OR OTHERWISE MADE WEATERTIGHT IN A MANNER COMPATIBLE TO THE EXISTING ASSEMBLY AND TO MATCH EXISTING SYSTEMS.
- ANY NEW PENETRATIONS OF THE BUILDING WEATHER ENVELOPE ARE TO BE CAULKED, SEALED, FLASHED, OR OTHERWISE MADE WEATERTIGHT IN A MANNER COMPATIBLE TO THE EXISTING ASSEMBLY AND TO MATCH EXISTING SYSTEMS.
- THE REPRESENTATION OF EXISTING BUILDING CONDITIONS IS PRIMARILY BASED ON PLANS PROVIDED BY OWNER AND ON DAG ARCHITECTS SITE VISIT OBSERVATIONS.
- DAG ARCHITECTS DID NOT PERFORM A COMPREHENSIVE FIELD SURVEY AND IS NOT TO BE HELD ACCOUNTABLE FOR INACCURATE DIMENSIONS OR HIDDEN CONDITIONS. ALL DIMENSIONS OF EXISTING CONDITIONS ARE TO FINISHED SURFACES, WERE HAND MEASURED AND MAY HAVE BEEN ROUNDED OFF TO THE VALUES. THE REPRESENTATION OF HIDDEN CONDITIONS IS BASED UPON DAG ARCHITECTS KNOWLEDGE OF TYPICAL CONSTRUCTION PRACTICES AND SHOULD BE VERIFIED BY THE CONTRACTOR.

GENERAL DEMO NOTES

- FIELD VERIFY ALL EXISTING CONDITIONS PRIOR TO PERFORMING ANY DEMOLITION OR NEW CONSTRUCTION. PROTECT ANY AND ALL ITEMS WHICH ARE TO REMAIN OR TO BE ALTERED.
- THE DEMOLITION DRAWINGS ARE NOT ALL INCLUSIVE OF ALL ITEMS THAT MAY BE REMOVED IN THE COURSE OF THE PROJECT. THE A/E RESERVES THE RIGHT TO INCLUDE ADDITIONAL DEMOLITION NOTES DISCOVERED DURING CONSTRUCTION.
- ALL RESTROOMS IN AREA OF WORK TO BE FULLY RENOVATED WITH ALL FLOOR, WALL, AND CEILING FINISHES TO BE REMOVED TO SUBSTRATE, TYPICAL.
- ALL MEP AND FIRE PROTECTION SYSTEMS AND/OR FIXTURES ARE TO BE EVALUATED BY A LICENSED ENGINEER AND UPGRADED WHERE POSSIBLE. ANY INDICATION OF ELEMENTS IN ARCHITECTURAL DRAWINGS DIAGRAMMATICALLY REFLECT AN AESTHETIC INTENT, BUT SHOULD BE COORDINATED WITH MEP AND FIRE PROTECTION DRAWINGS FOR FULL EXTENT OF CONSULTANT WORK. AT ANY POINT, WHERE DRAWINGS OF ONE SPECIALTY CONFLICT WITH ANOTHER, THE CONTRACTOR IS RESPONSIBLE FOR BRINGING DISCREPANCIES TO THE ATTENTION OF THE ARCHITECT PRIOR TO THE START OF WORK IN THAT AREA FOR CLARIFICATION OF DESIGN INTENT. ALL MEETING ROOM CEILINGS AND FLOORS ARE NOT INCLUDED IN THIS PHASE OF WORK AND ARE TO REMAIN AS IS, TYPICAL.

LEGEND

- DEMO EXISTING WALL
- DEMO EXISTING CONCRETE SLAB
- NOT IN CURRENT SCOPE OF WORK

KEYNOTES

NUMBER	DESCRIPTION
01.03	NOT PART OF THIS RENOVATION PHASE.
02.01	REMOVE EXISTING TILE TO SUBSTRATE & DISCARD.
02.02	REMOVE AND REPLACE EXISTING PLUMBING FIXTURES.
02.05	REMOVE EXISTING COUNTERTOPS AND BRACKET SUPPORTS.
02.10	REMOVE EXISTING WATER FOUNTAINS & REPLACE.
02.12	REMOVE & REPLACE EXISTING TOILET ACCESSORIES.
02.13	REMOVE & REPLACE EXISTING RESTROOM PARTITIONS.
02.15	REMOVE EXISTING DOOR AND REPLACE WITH CASED OPENING.
02.16	REMOVE EXISTING FLOORING TO SUBSTRATE IN ITS ENTIRETY AND DISCARD.

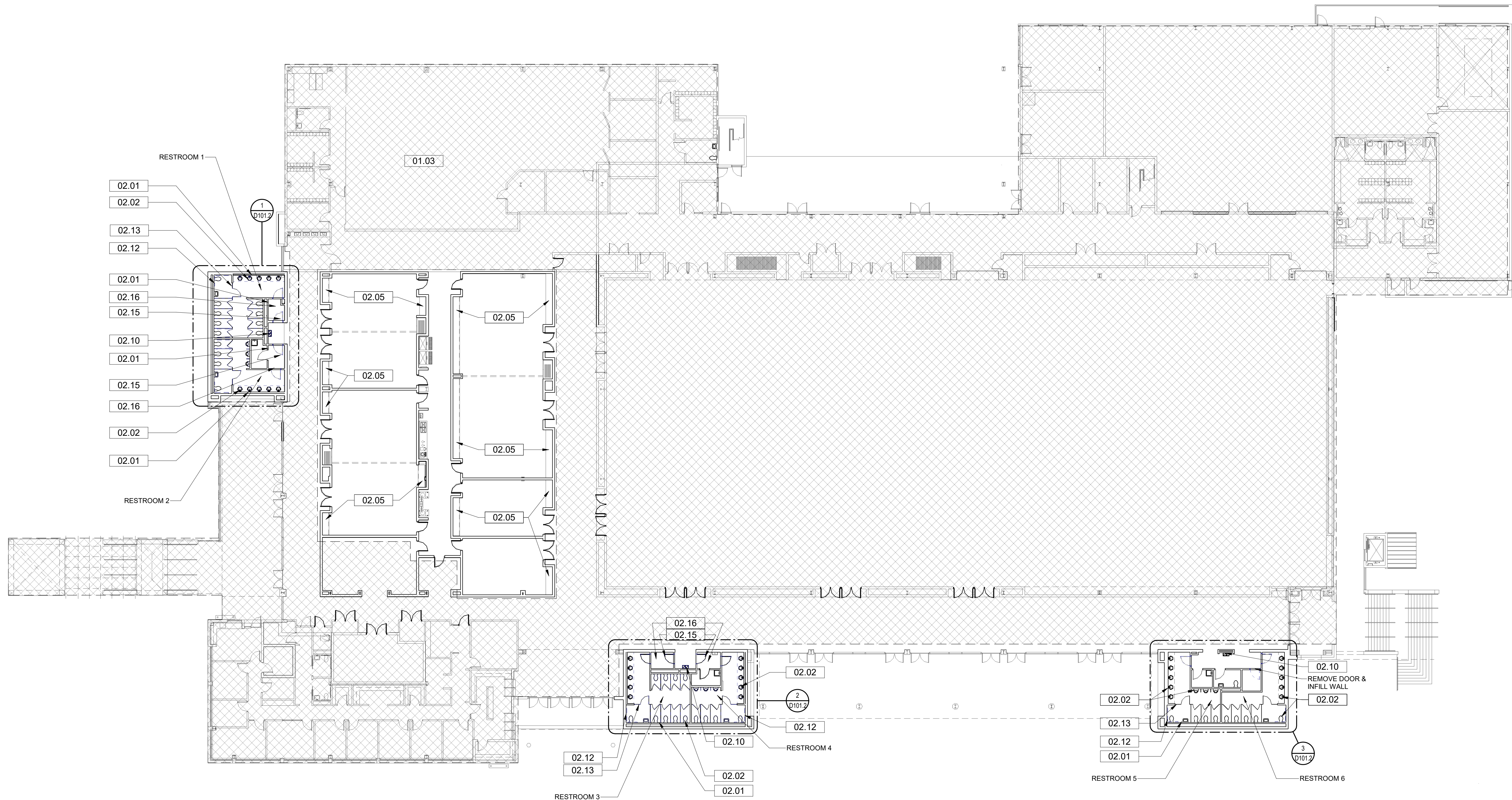

1 OVERALL EXHIBIT LEVEL DEMOLITION PLAN
 SCALE: 1/16" = 1'-0"



CONSULTANT OF RECORD
 ALL REPORTS, PLANS, SPECIFICATIONS, COMPUTER FILES, FIELD DATA, NOTES AND OTHER DOCUMENTS AND INSTRUMENTS PREPARED BY THE CONSULTANT AS AN INSTRUMENT OF SERVICE SHALL REMAIN THE PROPERTY OF THE CONSULTANT. THE CONSULTANT SHALL RETAIN ALL COMMON LAW, STATUTORY AND OTHER RESERVED RIGHTS, INCLUDING THE COPYRIGHT THERE TO.

PURSUANT TO FLORIDA STATUTES, SECTION 550.003, AN INDIVIDUAL EMPLOYEE OR AGENT MAY NOT BE HELD INDIVIDUALLY LIABLE FOR NEGLIGENCE.

BID DOCUMENTS

EMERALD COAST CONVENTION CENTER
RESTROOM RENOVATIONS & MEETING ROOM COUNTERS
 TASK ORDER NO. 5 - C-18-2638-TDD
 1250 MIRACLE STRIP PKWY SE
 FORT WALTON BEACH, FL 32548

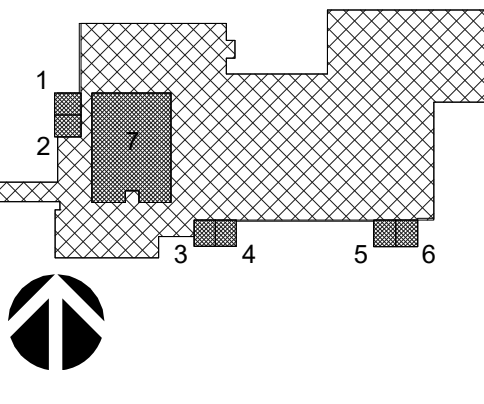

REVISIONS:

No.	Description	Date

DEMO PLAN - OVERALL

Project number	17057.5
Dated	JANUARY 2019
PIC	Approver
PM	Designer

D101.1

Scale As indicated



OWNERSHIP OF SERVICE
 ALL REPORTS, PLANS, SPECIFICATIONS, COMPUTER FILES, FIELD DATA, NOTES AND OTHER DOCUMENTS AND INSTRUMENTS PREPARED BY THE CONSULTANT AS AN INSTRUMENT OF SERVICES SHALL REMAIN THE PROPERTY OF THE CONSULTANT. THE CONSULTANT SHALL RETAIN ALL COMMON LAW, STATUTORY AND OTHER RESERVED RIGHTS, INCLUDING THE COPYRIGHT THEREON.

PURSUANT TO FLORIDA STATUTES, SECTION 550.0030, AN INDIVIDUAL EMPLOYEE OR AGENT MAY NOT BE HELD INDIVIDUALLY LIABLE FOR NEGLIGENCE.

BID DOCUMENTS

EMERALD COAST CONVENTION CENTER
 RESTROOM RENOVATIONS & MEETING ROOM
 COUNTERS
 TASK ORDER NO. 5 - C-18-2638-TDD
 1250 MIRACLE STRIP PKWY SE
 FORT WALTON BEACH, FL 32548

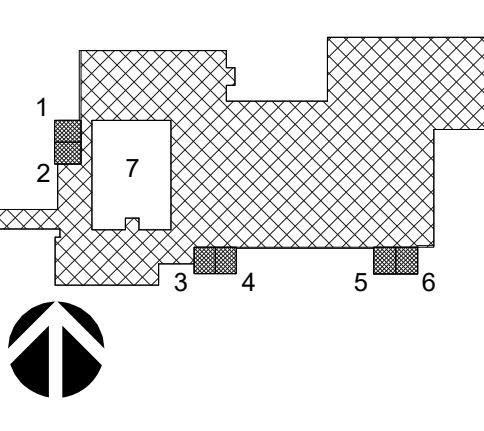

REVISIONS:

No.	Description	Date

ENLARGED DEMO RCP

Project number	17057.5
Dated	JANUARY 2019
PIC	Approver
PM	Designer

D101.2

Scale As indicated

GENERAL NOTES

- FIELD VERIFY ALL EXISTING CONDITIONS PRIOR TO PERFORMING ANY DEMOLITION OR NEW CONSTRUCTION. PROTECT ANY AND ALL ITEMS WHICH ARE TO REMAIN OR TO BE ALTERED.
- THE DEMOLITION DRAWINGS ARE NOT ALL INCLUSIVE OF ALL ITEMS THAT MAY BE REMOVED IN THE COURSE OF THE PROJECT. THE A/E RESERVES THE RIGHT TO INCLUDE ADDITIONAL DEMOLITION NOTES DISCOVERED DURING CONSTRUCTION.
- ALL RESTROOMS IN AREA OF WORK TO BE FULLY RENOVATED WITH ALL FLOOR, WALL, AND CEILING FINISHES TO BE REMOVED TO SUBSTRATE, TYPICAL.
- ALL MEETING ROOM CEILINGS AND FLOORS ARE NOT INCLUDED IN THIS PHASE OF WORK AND ARE TO REMAIN AS IS.
- ALL MEP AND FIRE PROTECTION SYSTEMS AND/OR FIXTURES TO BE EVALUATED BY A LICENSED ENGINEER AND UPGRADED WHERE POSSIBLE. ANY INDICATION OF ELEMENTS IN ARCHITECTURAL DRAWINGS DIAGRAMMATICALLY REFLECT AN AESTHETIC INTENT, BUT SHOULD BE COORDINATED WITH MEP AND FIRE PROTECTION DRAWINGS FOR FULL EXTENT OF CONSULTANT WORK AT ANY POINT. WHERE DRAWINGS OF ONE SPECIALTY CONFLICT WITH ANOTHER, THE CONTRACTOR IS RESPONSIBLE FOR BRINGING DISCREPANCIES TO THE ATTENTION OF THE ARCHITECT PRIOR TO THE START OF WORK IN THAT AREA FOR CLARIFICATION OF DESIGN INTENT.

RCP LEGEND

- LIGHT FIXTURES, SEE ELECTRICAL
- MECHANICAL DEVICES, SEE MECHANICAL
- 2' x 2' ACOUSTICAL CEILING TILE 9'-0" AFF UNLESS NOTED OTHERWISE, SEE FINISH SCHEDULE
- GYPSUM BOARD CEILING 9'-0" AFF UNLESS NOTED OTHERWISE, PROVIDE MOISTURE RESISTANT @ ALL WET AREAS AND JANITOR'S CLOSET
- PREFINISHED VENTILATED METAL SOFFIT PANELS
- WIRE CAGING MOUNTED TO UNDER SIDE OF TRUSS
- EXPOSED TO STRUCTURE
- SPEAKER SYSTEM, SEE FIRE ALARM
- EXIT LIGHT, SEE ELECTRICAL
- DIRECTIONAL EXIT LIGHT, SEE ELECTRICAL
- MOTION DETECTOR, SEE ELECTRICAL
- CEILING HEIGHT DESIGNATION
- EXPOSED CEILING
- PROJECTOR MOUNT
- ACCESS PANEL

DEMOLITION RCP LEGEND

- DEMOLISH EXISTING LIGHT FIXTURES, SEE ELECTRICAL
- DEMOLISH EXISTING MECHANICAL DEVICES, SEE MECHANICAL
- DEMOLISH EXISTING GYPSUM BOARD CEILING, UNLESS NOTED OTHERWISE,
- SPEAKER SYSTEM, SEE FIRE ALARM
- EXIT LIGHT TO REMAIN, SEE ELECTRICAL
- DIRECTIONAL EXIT LIGHT TO REMAIN, SEE ELECTRICAL
- MOTION DETECTOR, SEE ELECTRICAL
- CEILING HEIGHT DESIGNATION GIVEN IS EXISTING
- EXISTING SPRINKLERS REVISED, COORDINATE WITH MECHANICAL

KEYNOTES

NUMBER	DESCRIPTION
01.03	NOT PART OF THIS RENOVATION PHASE
02.06	REMOVE EXISTING LIGHT FIXTURES AND REPLACE WITH LED FIXTURES WHERE POSSIBLE. SEE ELECTRICAL FOR EXACT SPECIFICATIONS.
02.08	EXISTING CEILING TO REMAIN
02.09	EXISTING CEILING TO BE REMOVED.

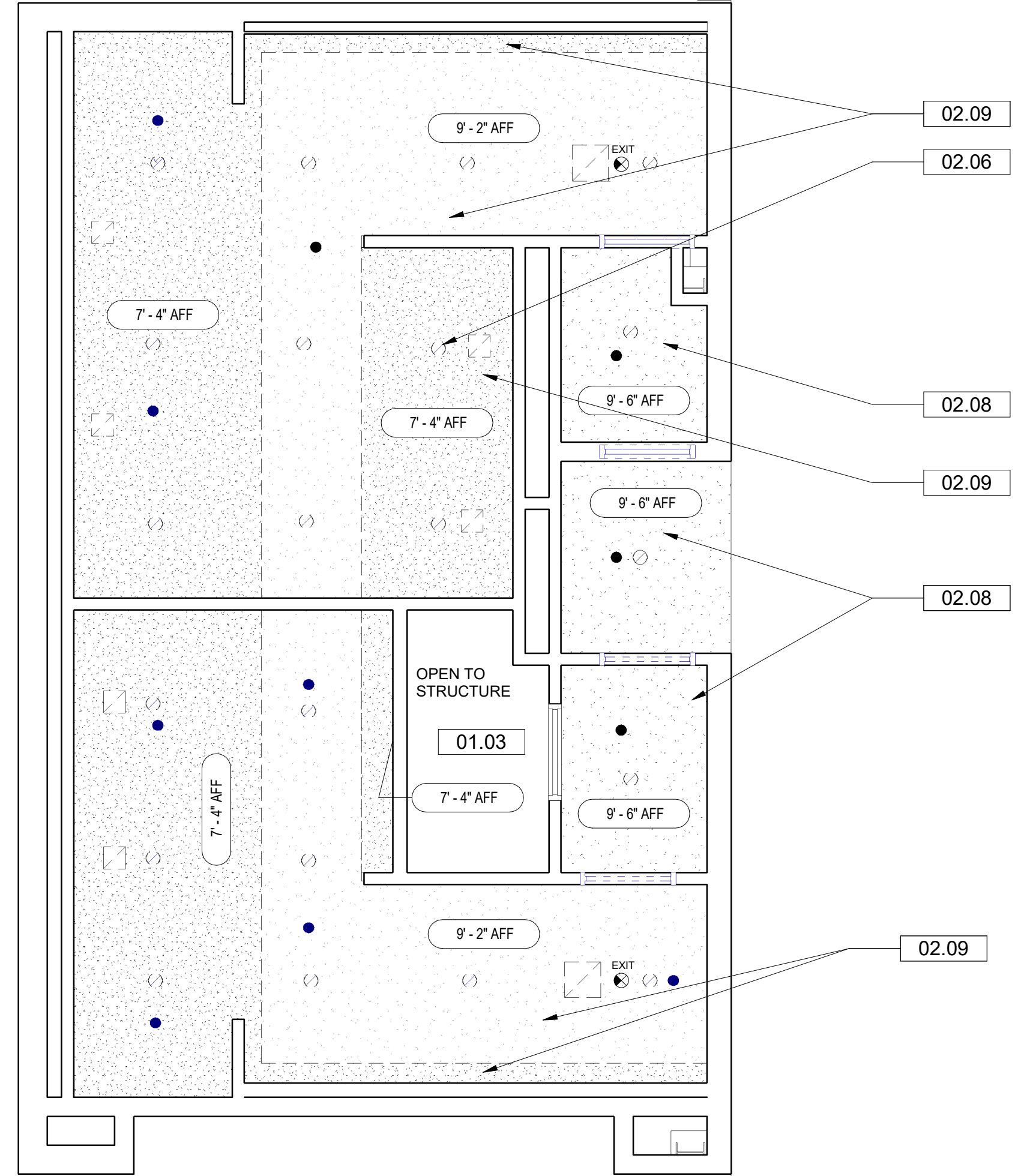

1 01_RCP_Demo - RR 1 & 2
 SCALE: 1/4" = 1'-0"

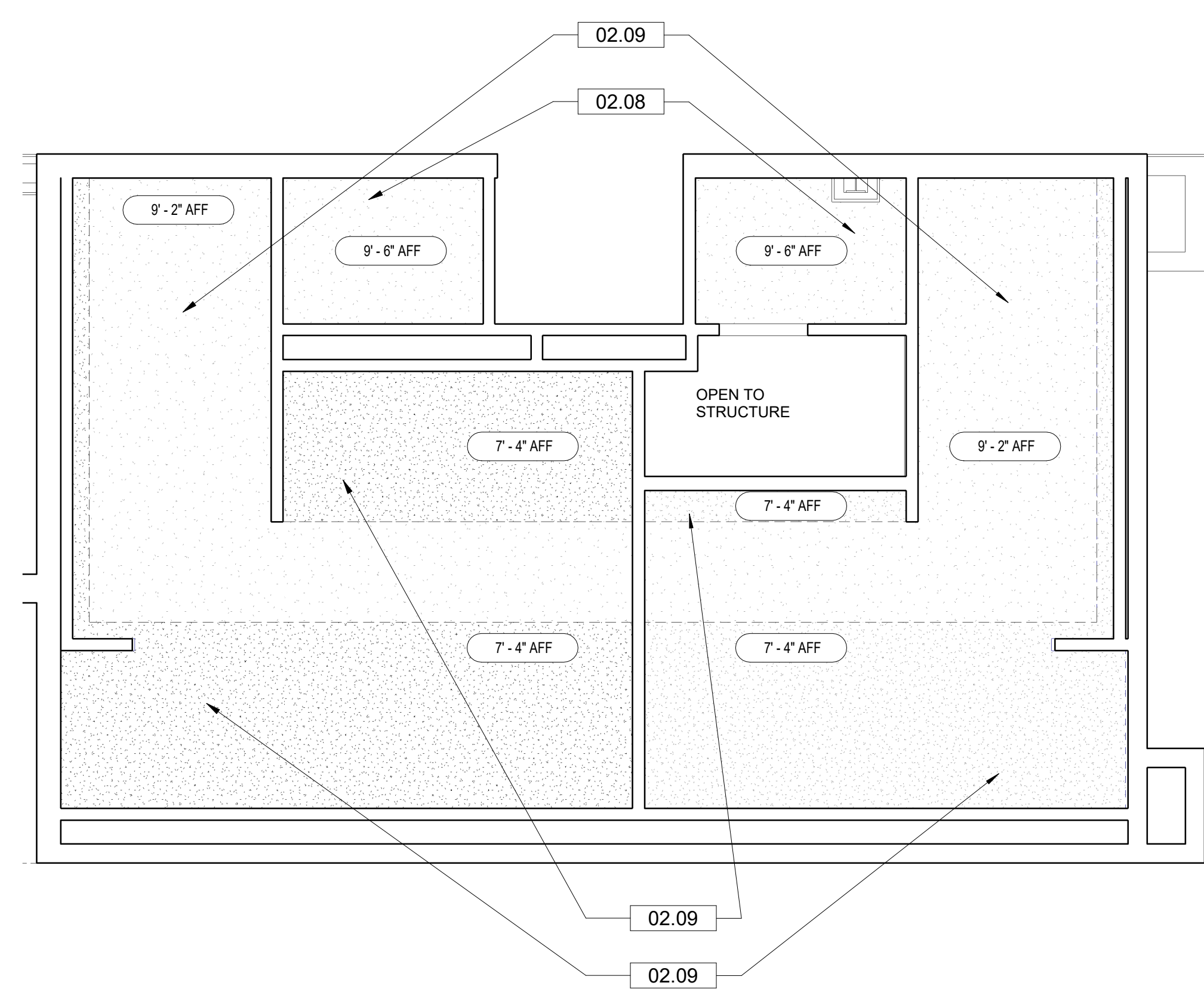

2 01_RCP_Demo - RR 3 & 4
 SCALE: 1/4" = 1'-0"

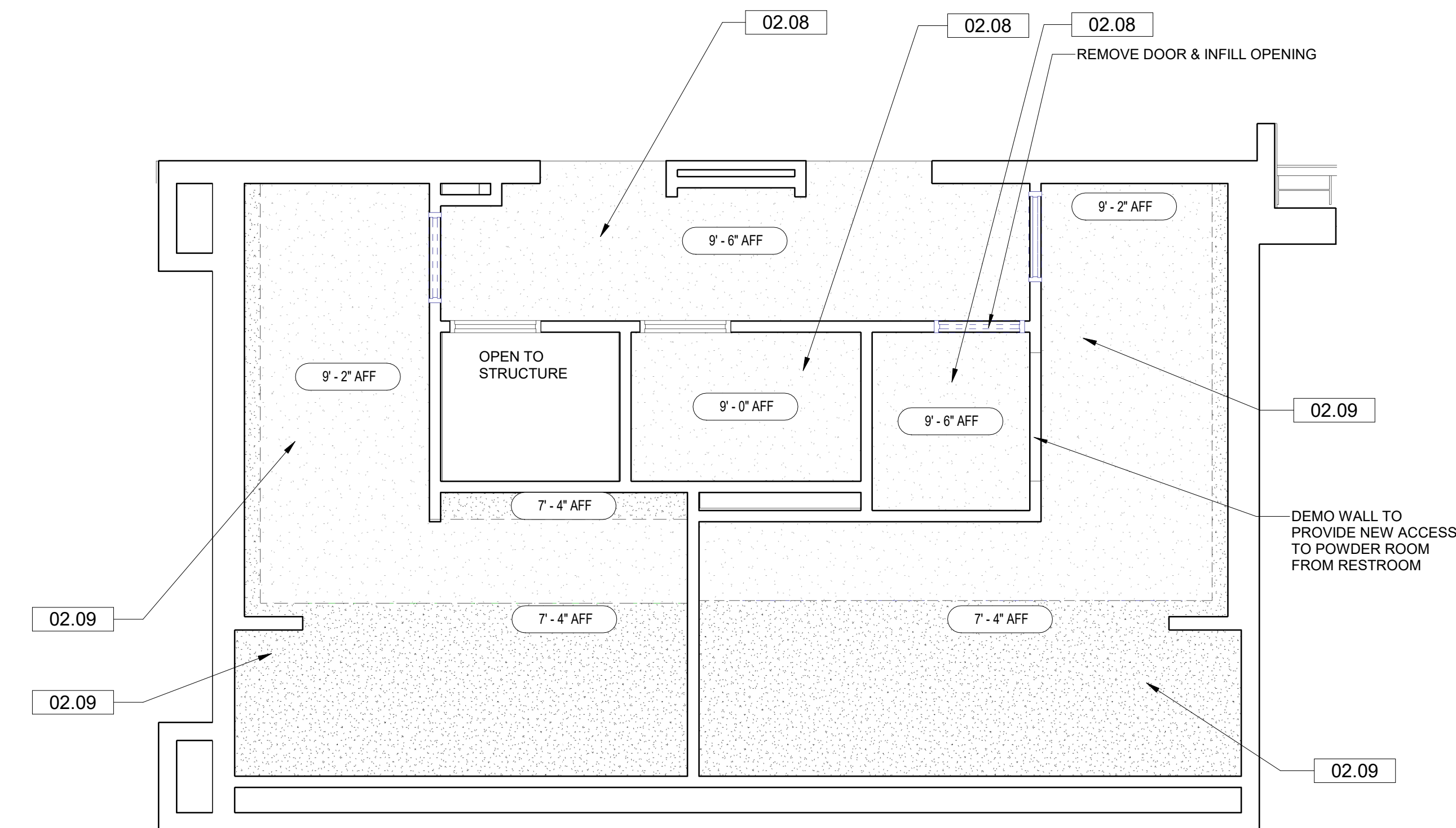

3 01_RCP_Demo - RR 5 & 6
 SCALE: 1/4" = 1'-0"

E
D
C
B
A

GENERAL NOTES

1. FIELD VERIFY ALL EXISTING CONDITIONS PRIOR TO PERFORMING NEW WORK.
2. THE CONTRACTOR SHALL PROVIDE REINFORCING BEHIND WALL MOUNTED AND CEILING MOUNTED EQUIPMENT. COORDINATE WITH A/V, DATA AND ELECTRICAL DRAWINGS.
3. CONTRACTOR SHALL COORDINATE WORK WITH MECHANICAL, ELECTRICAL AND PLUMBING DRAWINGS. SEE ENLARGED PLAN SHEETS (A401-A407) FOR FINISHES, FIXTURES, AND DIMENSIONS.
4. WHERE EXISTING OUTLETS CONFLICT WITH NEW CASEWORK, MOVE EXISTING OUTLETS ABOVE COUNTERTOP (COORDINATE WITH ELECTRICAL ENGINEER)

KEYNOTES

NUMBER	DESCRIPTION
01.03	NOT PART OF THIS RENOVATION PHASE.



OWNERSHIP OF SERVICE
 ALL REPORTS, PLANS, SPECIFICATIONS, COMPUTER FILES, FIELD DATA, NOTES AND OTHER DOCUMENTS AND INSTRUMENTS PREPARED BY THE CONSULTANT AS AN INSTRUMENT OF SERVICES SHALL REMAIN THE PROPERTY OF THE CONSULTANT. THE CONSULTANT SHALL RETAIN ALL COMMON LAW, STATUTORY AND OTHER RESERVED RIGHTS, INCLUDING THE COPYRIGHT THERE TO.

PURSUANT TO FLORIDA STATUTES, SECTION 550.0030, AN INDIVIDUAL EMPLOYEE OR AGENT MAY NOT BE HELD INDIVIDUALLY LIABLE FOR NEGLIGENCE.

BID DOCUMENTS

**EMERALD COAST CONVENTION CENTER
 RESTROOM RENOVATIONS & MEETING ROOM
 COUNTERS**
 TASK ORDER NO. 5 - C-18-2638-TDD
 1250 MIRACLE STRIP PKWY SE
 FORT WALTON BEACH, FL 32548

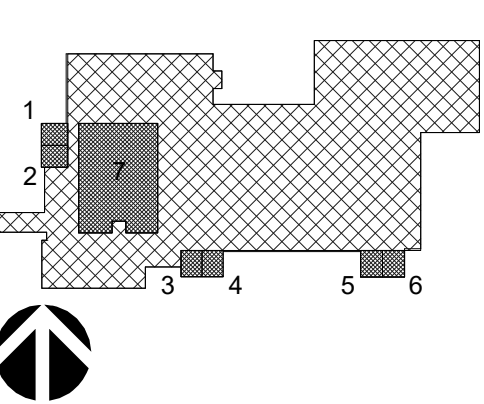

REVISIONS:

No.	Description	Date

OVERALL FIRST FLOOR PLAN

Project number	17057.5
Dated	JANUARY 2019
PIC	Approver
PM	Designer

A101
 Scale As indicated

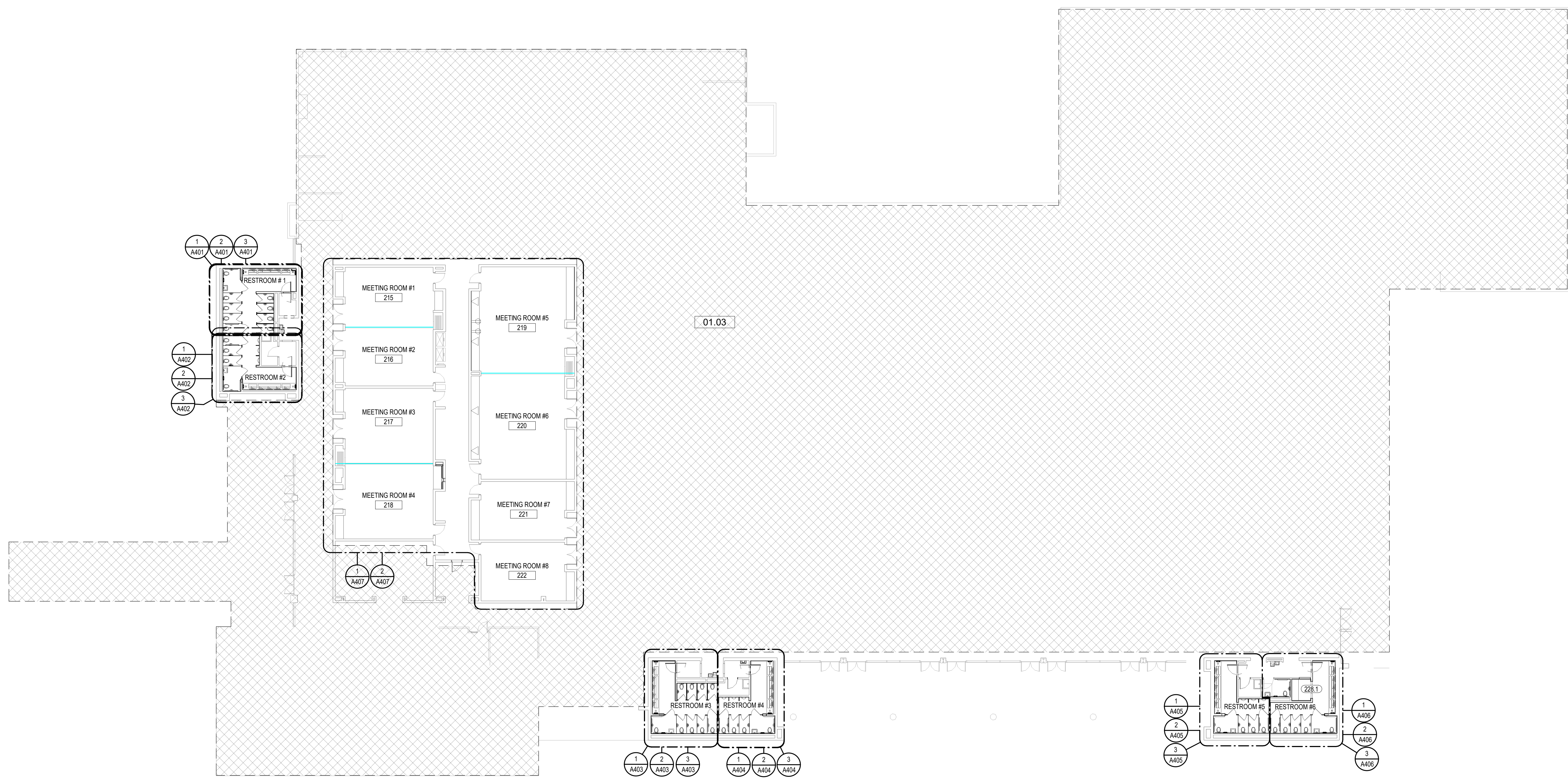

1 OVERALL FIRST FLOOR PLAN
 SCALE: 1/16" = 1'-0"

1 2 3 4 5 6

E
 D
 C
 B
 A

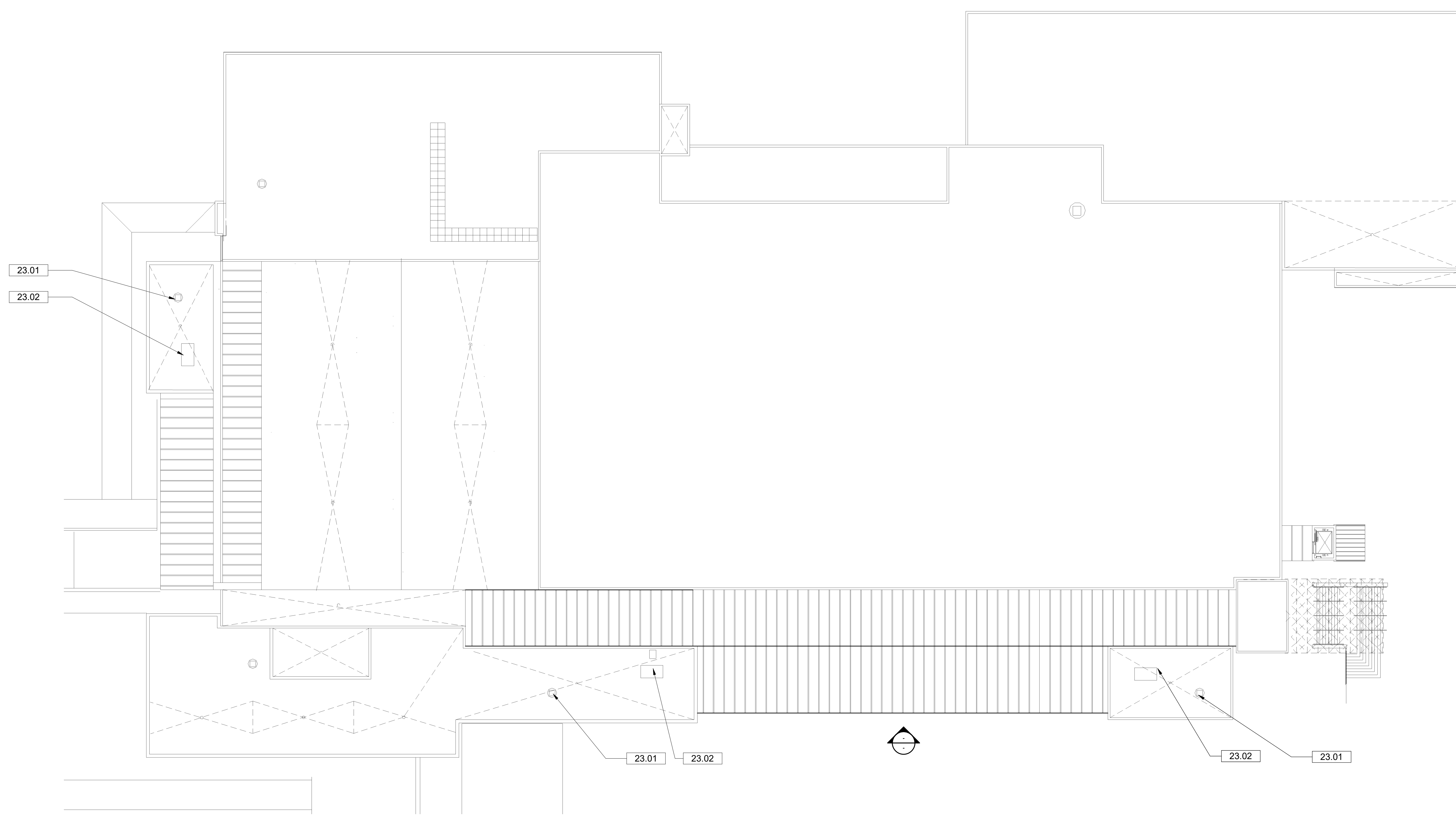

1 ROOF PLAN
 SCALE: 1/16" = 1'-0"

GENERAL NOTES: ROOF





1. FIELD VERIFY ALL EXISTING CONDITIONS PRIOR TO PERFORMING NEW WORK.
2. DRAWINGS PRESENTED ARE DIAGRAMMATIC REPRESENTATIONS FROM EXISTING AS-BUILT DRAWINGS, AND ROOF CONDITIONS HAVE NOT BEEN VERIFIED BY ARCHITECTURAL TEAM.
3. THE CONTRACTOR SHALL PROVIDE REINFORCING AS NECESSARY BENEATH ROOF SURFACE MOUNTED AND CEILING MOUNTED EQUIPMENT. COORDINATE WITH ALL TRADES.
4. ANY ADDED PENETRATIONS IN ROOF MUST BE FLASHED APPROPRIATELY TO PREVENT WATER INTRUSION.

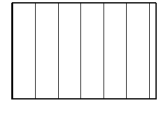
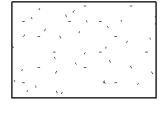

OWNERSHIP OF SERVICE
 ALL REPORTS, PLANS, SPECIFICATIONS, COMPUTER FILES, FIELD DATA, NOTES AND OTHER DOCUMENTS AND INSTRUMENTS PREPARED BY THE CONSULTANT AS AN INSTRUMENT OF SERVICES SHALL REMAIN THE PROPERTY OF THE CONSULTANT. THE CONSULTANT SHALL RETAIN ALL COMMON LAW, STATUTORY AND OTHER RESERVED RIGHTS, INCLUDING THE COPYRIGHT THERE TO.

PURSUANT TO FLORIDA STATUTES, SECTION 550.0030, AN INDIVIDUAL EMPLOYEE OR AGENT MAY NOT BE HELD INDIVIDUALLY LIABLE FOR NEGLIGENCE.

LEGEND

-  EXISTING STANDING SEAM METAL ROOF SYSTEM
-  EXISTING ROOF MEMBRANE
-  OUTLINE OF BUILDING BELOW
-  MECHANICAL EQUIPMENT, SEE MECHANICAL
-  ROOF CURB
-  EXHAUST FAN, SEE MECHANICAL

KEYNOTES

NUMBER	DESCRIPTION
23.01	CONTRACTOR TO CONNECT NEW RESTROOM VENTILATION TO EXISTING MECHANICAL SYSTEM.
23.02	NEW HVAC ROOF UNIT. COORDINATE MOUNTING AND CURBING REQUIREMENTS WITH EXISTING ROOF STRUCTURE

BID DOCUMENTS

**EMERALD COAST CONVENTION CENTER
 RESTROOM RENOVATIONS & MEETING ROOM
 COUNTERS**
 TASK ORDER NO. 5 - C-18-2638-TDD
 1250 MIRACLE STRIP PKWY SE
 FORT WALTON BEACH, FL 32548

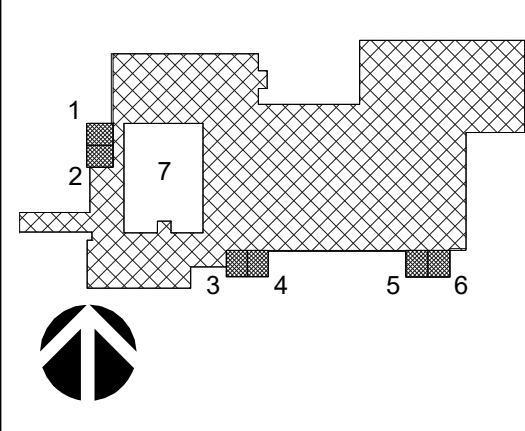

REVISIONS:

No.	Description	Date

OVERALL ROOF PLAN

Project number	17057.5
Dated	JANUARY 2019
PIC	Approver
PM	Designer

A102

Scale As indicated

E
 D
 C
 B
 A

PAINT		PARTITIONS	
P-1	MANUF: SHERWIN WILLIAMS COLOR: CITYSCAPE COLOR # 7067 FINISH: SEMI-GLOSS NOTE: ALCOVE COLOR IN MEETING ROOMS	EQTZ-1	MANUF: SILESTONE COLOR: ETERNAL CALACATTA CLASSIC COLOR # FINISH: POLISHED HARDWARE FINISH: SATIN NOTE: STONE PLY IS THE INNER STRUCTURE WITH QTZ AS SURFACE MATERIAL CONTACT: NAME ASHLEA WHEELER PHONE # 903.454.4630
P-2	MANUF: SHERWIN WILLIAMS COLOR: COLOR MATCH TO BENJAMIN MOORE OC-56 MOONSHINE FINISH: SEMI-GLOSS NOTE: OVERALL MEETING ROOM COLOR		
P-3	MANUF: SHERWIN WILLIAMS COLOR: WHITE, TBD COLOR # FINISH: FLAT NOTE: CEILING PAINT	PLASTIC LAMINATE	
P-4	MANUF: SHERWIN WILLIAMS COLOR: GRAY MATTERS COLOR # 7066 FINISH: SEMI-GLOSS NOTE: RESTROOM VESTIBULE COLOR	PL-1	MANUFACTURER: WILSONART PRODUCT # 7964 COLOR: SKYLINE WALNUT FINISH: STANDARD CONTACT:
TILE		COUNTERTOPS	
PT-1	MANUF: PORCELANOSA COLOR: AVENUE GREY LAPPATO COLOR # C220400321-100143115 FINISH: LAPPATO NOTE: 12"x24" HORIZONTAL RUNNING BOND CONTACT: NAME MIGUEL RODRIGUEZ PHONE # 305.522.7306	QTZ-1	MANUFACTURER: SILESTONE PRODUCT # COLOR: STELLAR SNOW 13 FINISH: POLISHED CONTACT:
GT-1	MANUF: BODESI COLOR: CUSTOM HAND PAINTED BY MANF. COLOR # 6254 + 6388 (80) FINISH: NOTE: 4X12" VERTICAL STACK BOND CONTACT: NAME BO WOJTYRA PHONE # 1.888.658.2488	SS-1	MANUFACTURER: LIVING STONE PRODUCT # L713 COLOR: SHORELINE FINISH: CONTACT: NAME MITCH WEIR PHONE # 901-361-0038
GT-2	MANUF: ELIDA CERAMICA ITEM # 915526 MODEL # GPLW COLOR: WHITE FINISH: GLOSSY NOTE: DECORATIVE PENCIL LINER CONTACT: NAME PHONE #	SS-2	MANUFACTURER: CORIAN PRODUCT # COLOR: GLACIER FINISH: NOTE: SINK BASIN AND SINK SURROUND CONTACT: NAME PHONE #
G-1	MANF: TAC COLOR: CHARCOAL GRAY COLOR # 929 FINISH: NOTE: OR SIMILAR	SPECIALTY	
G-2	MANF: TAC COLOR: SILVERADO COLOR # 949 FINISH: NOTE: OR SIMILAR	S1	MANUFACTURER: D13 PRODUCT # COLOR: FINISH: CONTACT:
FLOORING			
LVT-1	MANUFACTURER: TANDUS CENTVA PRODUCT # PCFN 10023 COLOR: GREY/ GREEN CUSTOM FINISH: EMBOSSED IN QU (QUARRY) NOTE: MATCH TO EXISTING HALL MATERIAL CONTACT: NAME GINGER DYSON PHONE # 1.251.604.6887		
RB-1	MANUFACTURER: JOHNSONITE PRODUCT: MILLWORK MONARCH PRODUCT # MW-01-M COLOR # CHARCOAL WG 20 NOTE: MATCH TO EXISTING BASE IN HALL CONTACT: NAME GINGER DYSON PHONE # 1.251.604.6887		
WB-1	MANUFACTURER: SHERWIN WILLIAMS PRODUCT: PAINT SEMI-GLOSS COLOR CODE: SW 7068 COLOR NAME # GRIZZLE GRAY NOTE: MATCH TO RUBBER BASE COLOR		

FINISH LEGEND

FINISH SYMBOLS

- WALL AND BASE FINISH
- WALL FINISH
- FLOOR FINISH
- CHANGE IN SPECIFIED FINISH- PROVIDE TRANSITION STRIP AS REQUIRED
- DIRECTION OF SPECIFIED FINISH

FLOORING

- MATERIAL 1, PT-1
- MATERIAL 2, LVT-1

WALLS

- TILE 1, PT-1
- TILE 2, GT-1
- TILE 3, CT-1
- EQTZ- 1

COUNTERTOPS

- QTZ- 1
- SS-1
- SS- 2



OWNERSHIP OF SERVICE
 ALL REPORTS, PLANS, SPECIFICATIONS, COMPUTER FILES, FIELD DATA, NOTES AND OTHER DOCUMENTS AND INSTRUMENTS PREPARED BY THE CONSULTANT AS AN INSTRUMENT OF SERVICES SHALL REMAIN THE PROPERTY OF THE CONSULTANT. THE CONSULTANT SHALL RETAIN ALL COMMON LAW, STATUTORY AND OTHER RESERVED RIGHTS, INCLUDING THE COPYRIGHT THERE TO.

PURSUANT TO FLORIDA STATUTES, SECTION 550.0030, AN INDIVIDUAL EMPLOYEE OR AGENT MAY NOT BE HELD INDIVIDUALLY LIABLE FOR NEGLIGENCE.

BID DOCUMENTS

EMERALD COAST CONVENTION CENTER
 RESTROOM RENOVATIONS & MEETING ROOM
 COUNTERS
 TASK ORDER NO. 5 - C-18-2638-TDD
 1250 MIRACLE STRIP PKWY SE
 FORT WALTON BEACH, FL 32548

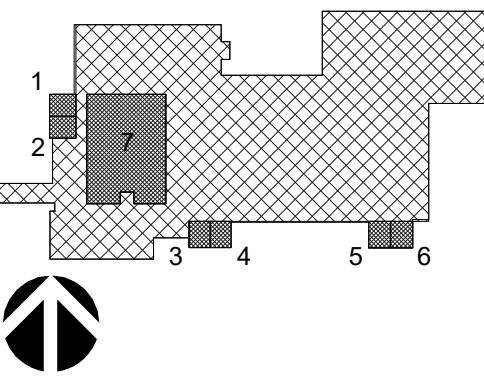

REVISIONS:

No.	Description	Date

INTERIOR FINISH LEGEND

Project number	17057.5
Dated	JANUARY 2019
PIC	Approver
PM	Designer

A400

Scale As indicated

DOOR SCHEDULE

MARK	DOOR			SIZE		FRAME		HARDWARE SET	COMMENTS
	DOOR MATERIAL	DOOR TYPE		WIDTH	HEIGHT	FRAME TYPE	FRAME MATERIAL		
223	WD	DL		3'-0"	7'-0"	HM-4	HM	SEE SPECIFICATIONS	
223.1	CO			3'-0"	7'-0"	HM-4	HM	n/a	
224	WD	DL		3'-0"	7'-0"	HM-4	HM	SEE SPECIFICATIONS	
224.1	-	CO		3'-0"	7'-0"	HM-4	HM	n/a	
225	WD	DL		3'-0"	7'-0"	HM-4	HM	SEE SPECIFICATIONS	
225.1	CO			3'-0"	7'-0"	HM-4	HM	n/a	
226	WD	DL		3'-0"	7'-0"	HM-4	HM	SEE SPECIFICATIONS	
226.1	-	CO		3'-0"	7'-0"	HM-4	HM	n/a	
227	WD	DL		3'-0"	7'-0"	HM-4	HM	SEE SPECIFICATIONS	
228	WD	DL		3'-0"	7'-0"	HM-4	HM	SEE SPECIFICATIONS	
228.1	-	CO		5'-0"	7'-0"	HM-4	HM	n/a	



OWNERSHIP OF SERVICE
 ALL REPORTS, PLANS, SPECIFICATIONS, COMPUTER FILES,
 FIELD DATA, NOTES AND OTHER DOCUMENTS AND
 INSTRUMENTS PREPARED BY THE CONSULTANT AS AN
 INSTRUMENT OF SERVICE SHALL REMAIN THE PROPERTY OF
 THE CONSULTANT. THE CONSULTANT SHALL RETAIN ALL
 COMMON LAW, STATUTORY AND OTHER RESERVED RIGHTS,
 INCLUDING THE COPYRIGHT THERE TO.

PURSUANT TO FLORIDA STATUTES, SECTION 550.0030, AN
 INDIVIDUAL EMPLOYEE OR AGENT MAY NOT BE HELD
 INDIVIDUALLY LIABLE FOR NEGLIGENCE.

BID DOCUMENTS

EMERALD COAST CONVENTION CENTER
 RESTROOM RENOVATIONS & MEETING ROOM
 COUNTERS
 TASK ORDER NO. 5 - C-18-2638-TDD
 1250 MIRACLE STRIP PKWY SE
 FORT WALTON BEACH, FL 32548

GEN. NOTES: ENLG. PLAN

1. FIELD VERIFY ALL EXISTING CONDITIONS PRIOR TO PERFORMING NEW WORK.
2. THE CONTRACTOR SHALL PROVIDE REINFORCING BEHIND WALL MOUNTED AND CEILING MOUNTED EQUIPMENT.
3. CONTRACTOR SHALL COORDINATE WORK WITH MECHANICAL, ELECTRICAL AND PLUMBING DRAWINGS.
4. REFER TO FINISH LEGEND ON SHEET A400 FOR MORE INFORMATION ABOUT FINISHES SHOWN ON THIS SHEET.
5. PROVIDE POSITIVE SLOPE TOWARDS ALL FLOOR DRAINS.
6. ALL BATHROOM STALLS ARE TO BE COMPOSITE STONE-PLY TOILET COMPARTMENT SYSTEM WITH EOTZ-1 VENEER. INSTALL PER MANUFACTURER'S RECOMMENDATIONS.
7. STALL DOORS SHOWN IN ENLARGED FLOORPLANS AS A-H FOR PARTITION HARDWARE COORDINATION ONLY. NOT RELEVANT TO DOOR SCHEDULE.

GENERAL NOTES: RCP

1. SEE SHEET A400 FOR ROOM FINISH SCHEDULE FOR ADDITIONAL INFORMATION.
2. ALL ACCESS PANEL LOCATIONS TO BE COORDINATED WITH MECHANICAL, ELECTRICAL, PLUMBING AND FIRE SPRINKLER WORK.
3. REPLACE CEILING AT NEW HEIGHT IN RESTROOMS #1 TO #6.
4. UPGRADE FIXTURES WHERE POSSIBLE.
5. SEE ELECTRICAL FOR LIGHTING FIXTURE SCHEDULE WHERE APPLICABLE. ALL FIRE SPRINKLER HEADS AND ELECTRICAL FIXTURES SHALL BE CENTERED WITHIN CEILING TILES.
6. IF ANY ITEMS INDICATED ON THE DRAWINGS ARE IN CONFLICT WITH ONE ANOTHER, CONTRACTOR IS RESPONSIBLE FOR BRINGING TO ARCHITECT FOR FURTHER CLARIFICATION ON DESIGN INTENT.

KEYNOTES

NUMBER	DESCRIPTION
09.07	PT-1 PORCELAIN TILE: PORCELANOSA AVENUE GREY, 12X24, FINISH LAPPATO
09.08	GT-1 GLASS TILE: BODESI HAND PAINTED GLASS TILE, 4X12 CUSTOM COLOR
09.09	GT-2 GLASS PENCIL LINER: ELIDA CERAMICA 12X0.51, GLOSSY (OR SIMILAR)
9.12	EOTZ-1 ENGINEERED QUARTZ: SILESTONE, ETERNAL CALACATTA CLASSIC, POLISHED
10.04	RAKKS EHVAVANTY SUPPORT BRACKET SINK SURROUND (ADA INSTALLMENT AROUND SINK) CORIAN SOLID SURFACE PANELS
11.01	TORK HAND TOWEL DISPENSER, 562520, WHITE, OWNER PROVIDED, CONTRACTOR INSTALLED
11.02	TORK 3 ROLL BATH TISSUE ROLL DISPENSER, 56828, WHITE, OWNER PROVIDED, CONTRACTOR INSTALLED
11.03	MIRROR: PARIS MIRROR: LIGHTED MIRROR HARMONY: 24X48" LED 110V WIRING
11.04	MIRROR: PARIS MIRROR: LIGHTED MIRROR HARMONY: 24X32" LED 110V WIRING
11.05	SD: SOAP DISPENSER; OWNER PROVIDED, CONTRACTOR INSTALLED
11.06	WATER COOLER SPECIFIED BY WATERFORD PLUMBING ENGINEER
11.07	GB: GRAB BAR (ADA HEIGHT) MOUNTED BETWEEN 33-36" AFF
11.08	CHANGING TABLE: KOALA KARE KB200-05, WHITE GRANITE, MOUNTED 24" AFF
11.09	ADA ADULT TOILET (WALL MOUNTED)
11.11	ADA SINK SPECIFIED BY WATERFORD PLUMBING ENGINEER
26.11	LED LIGHTING UNDER SINK SYSTEM (ATTACHMENT NOT INCLUDED WITH SINK SYSTEM)

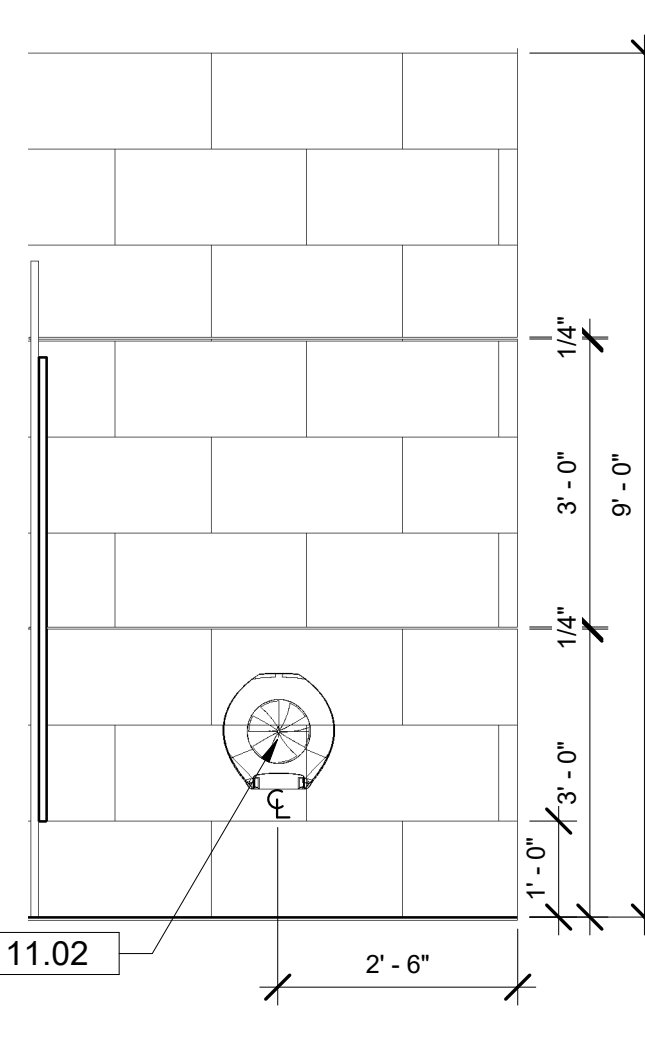
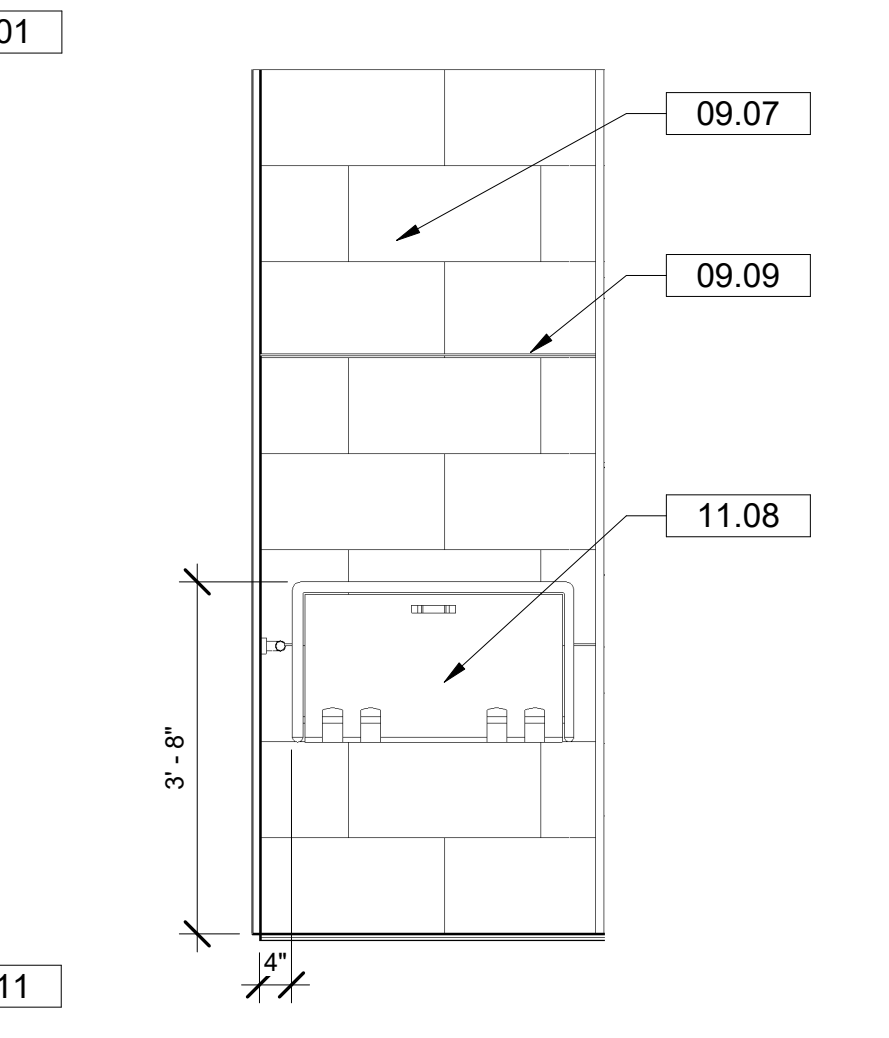
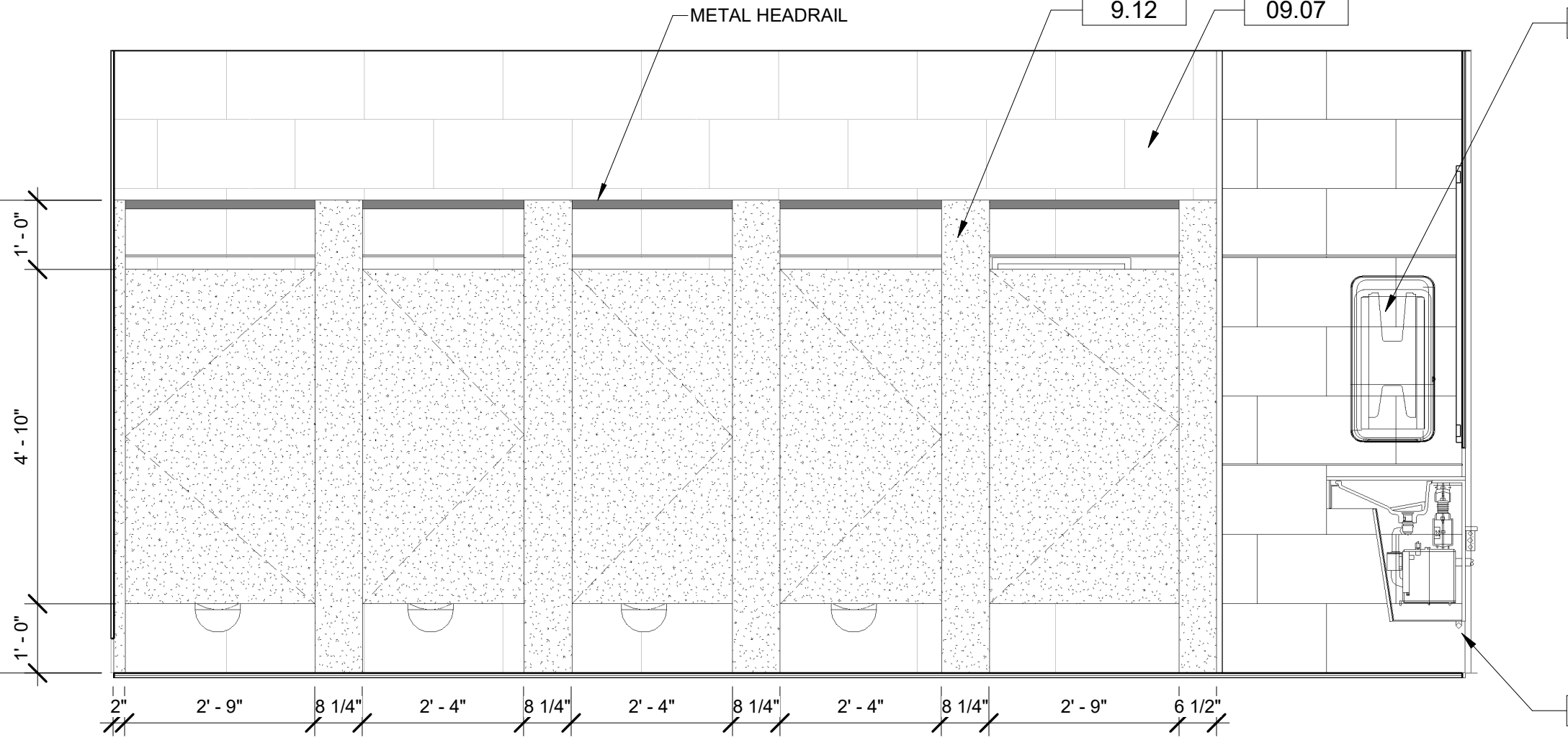
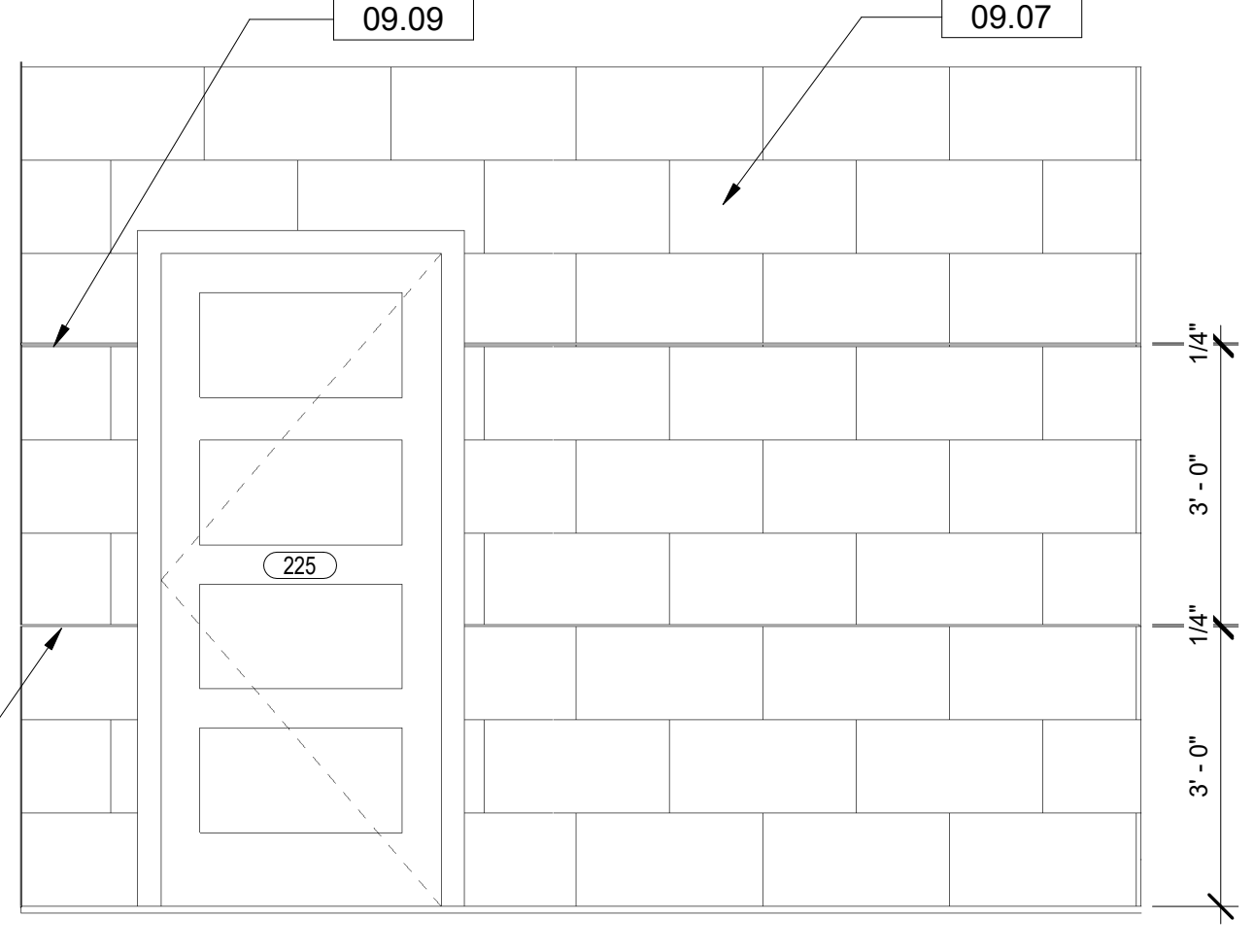
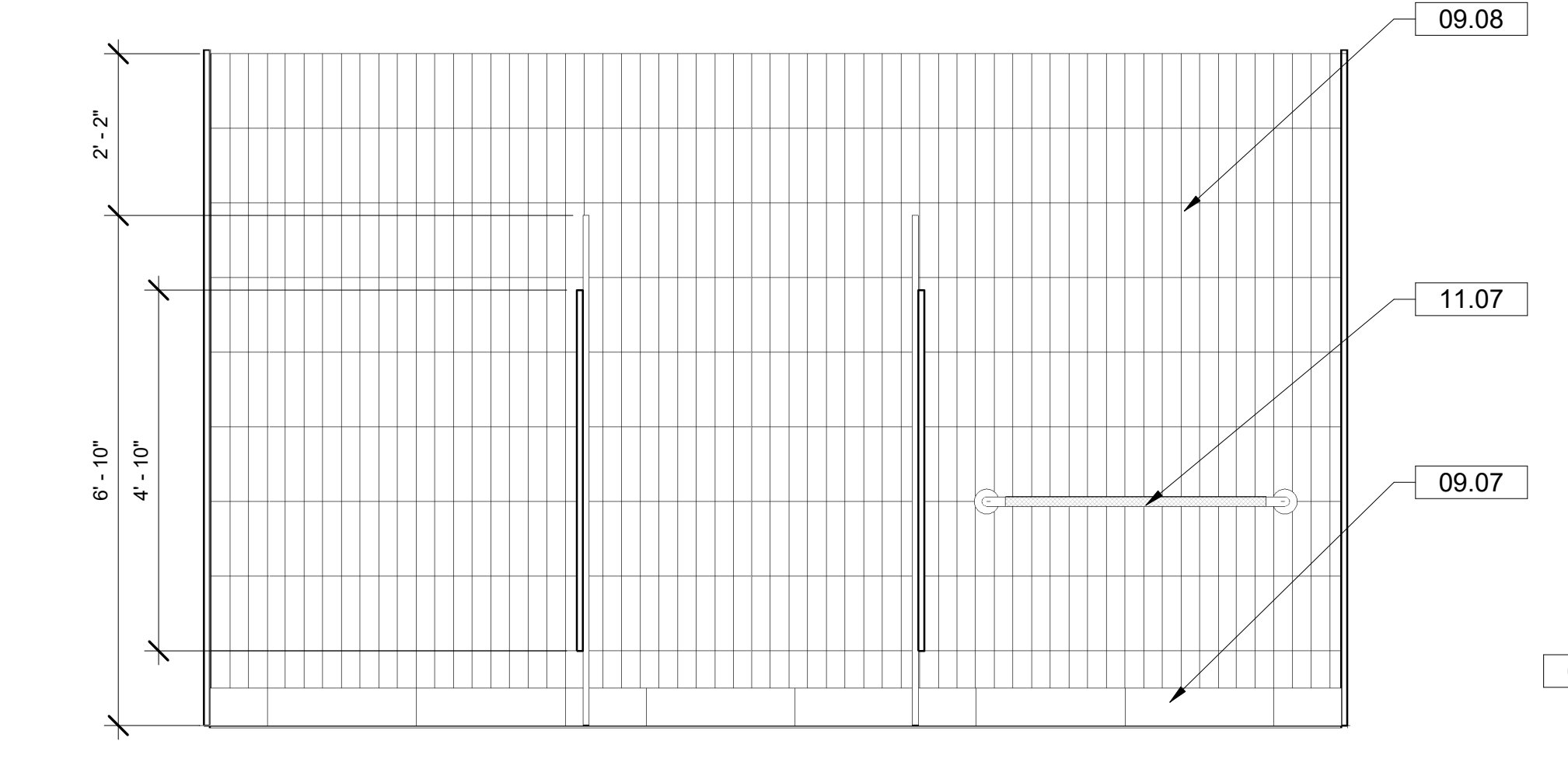
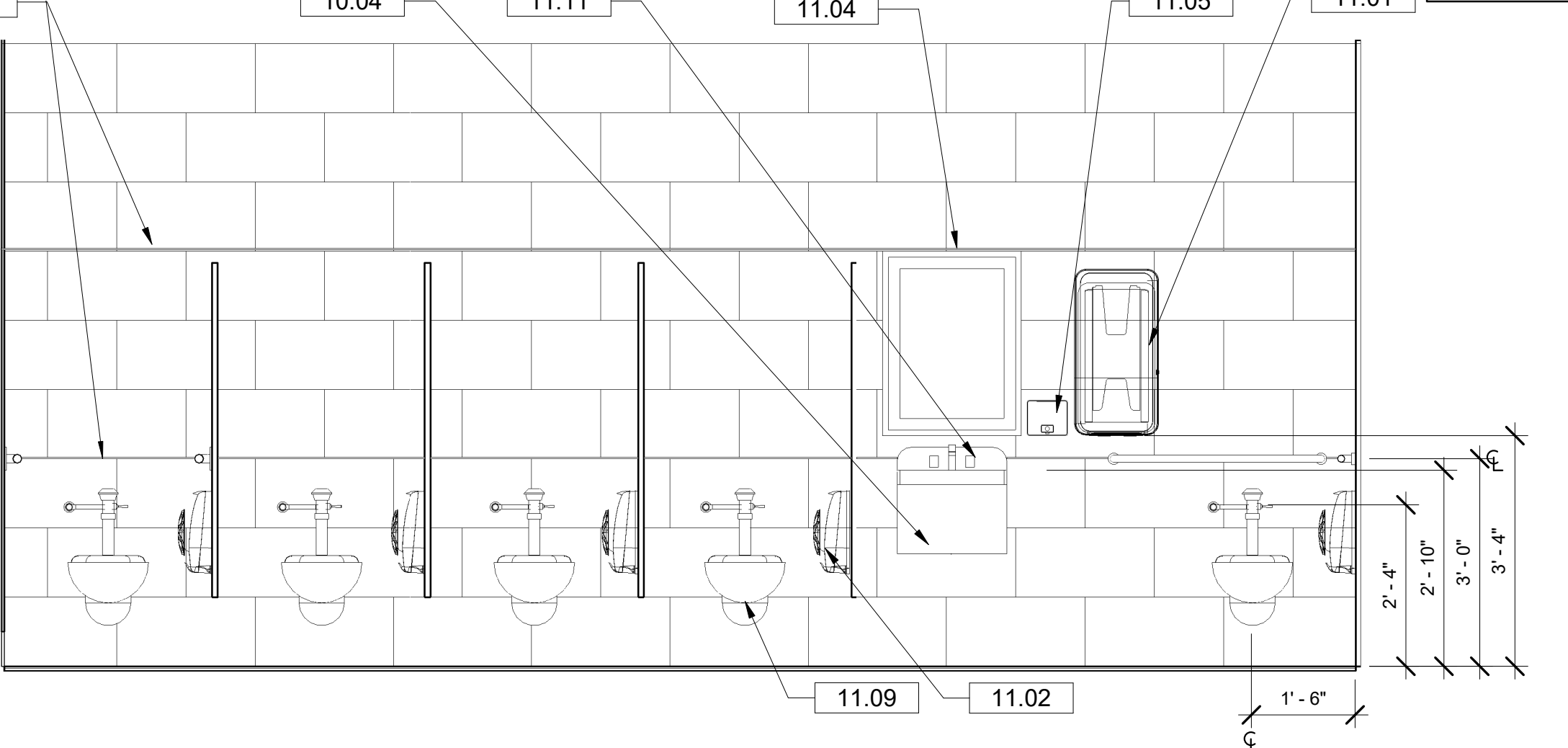
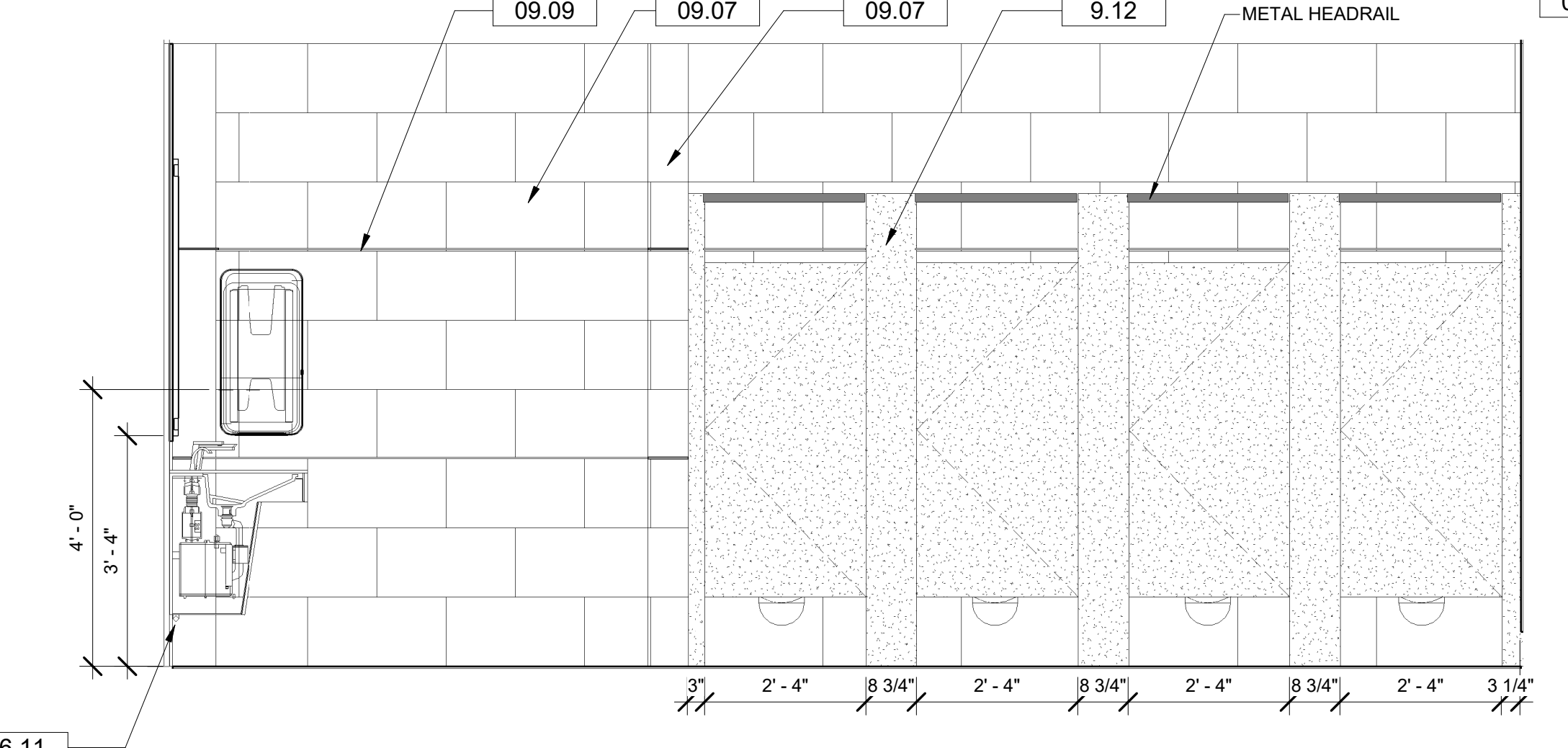
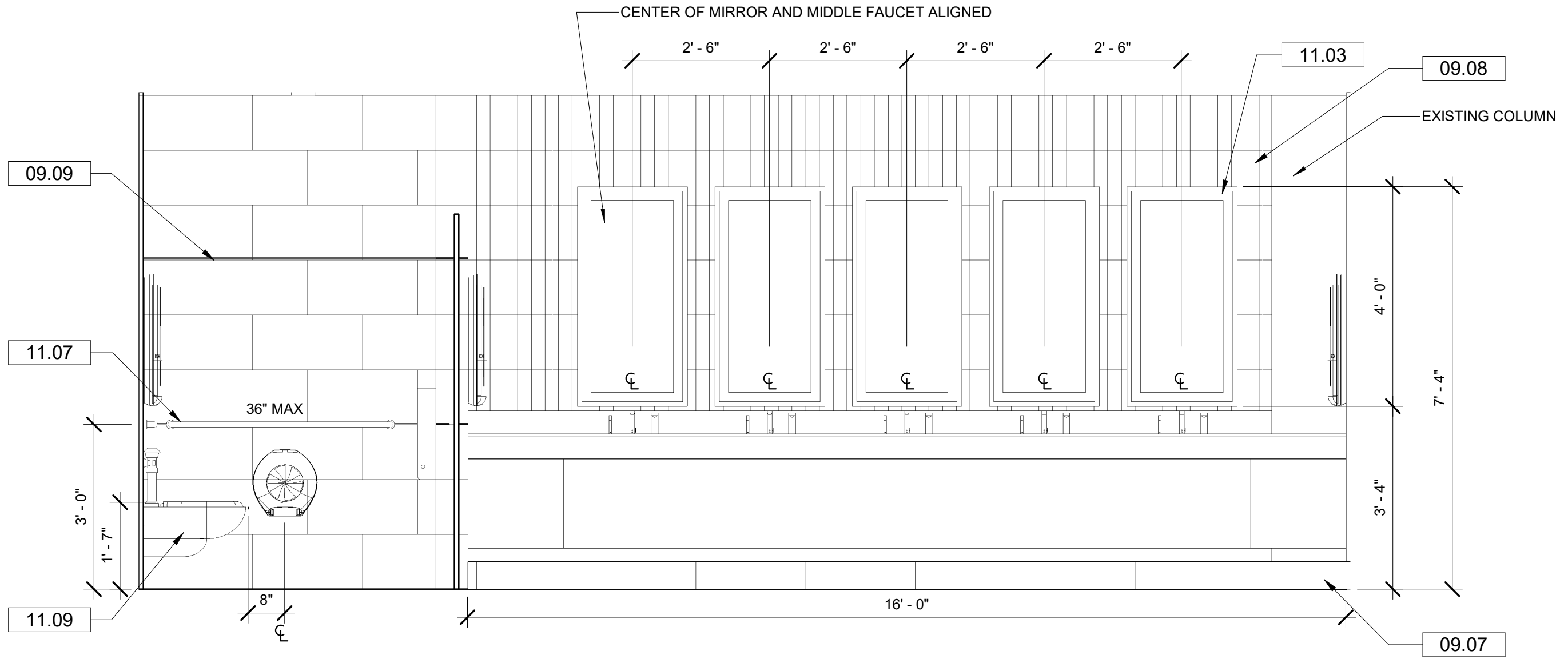
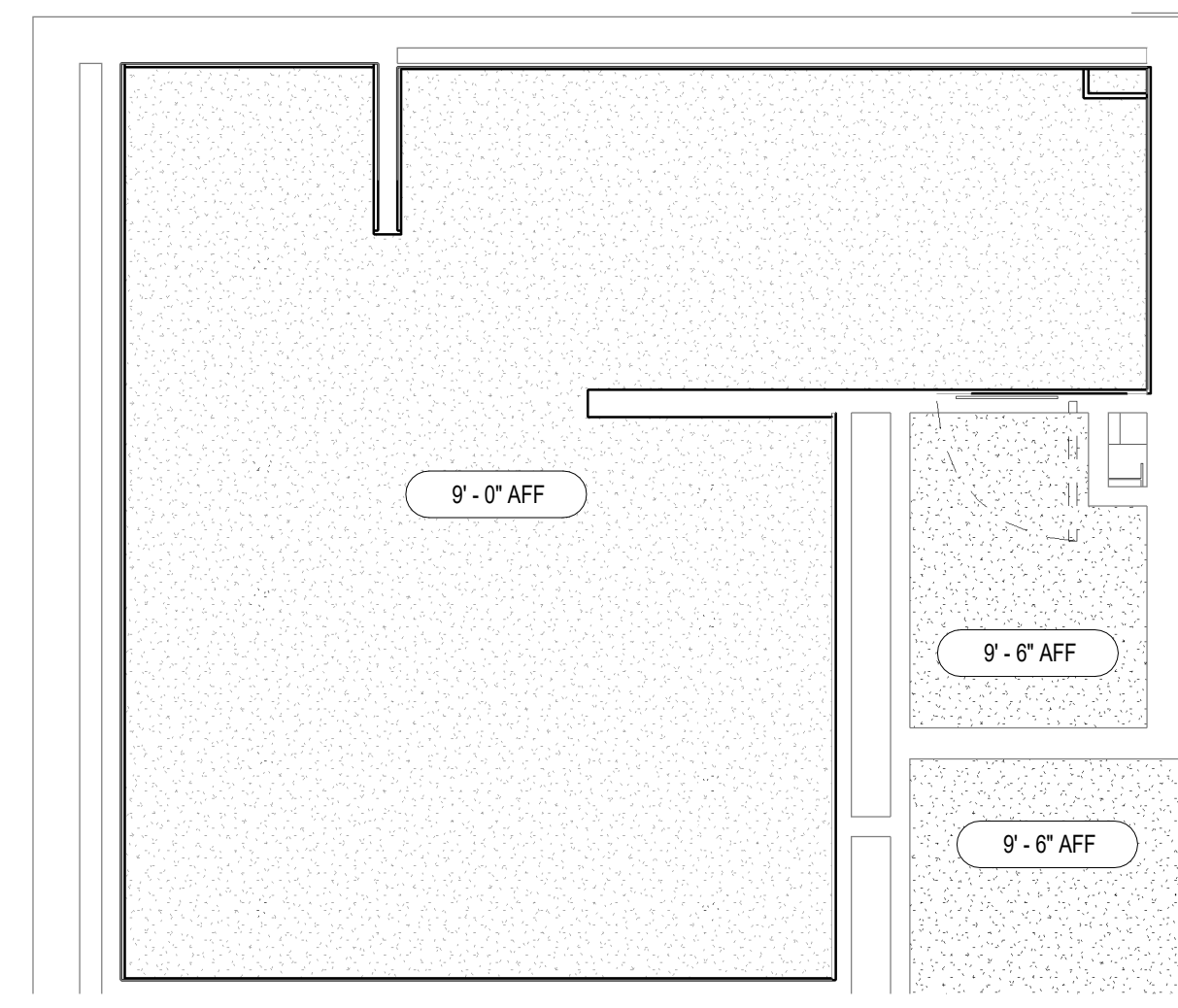

3 LVL 01 RCP - RESTROOM 1
 SCALE: 1/4" = 1'-0"

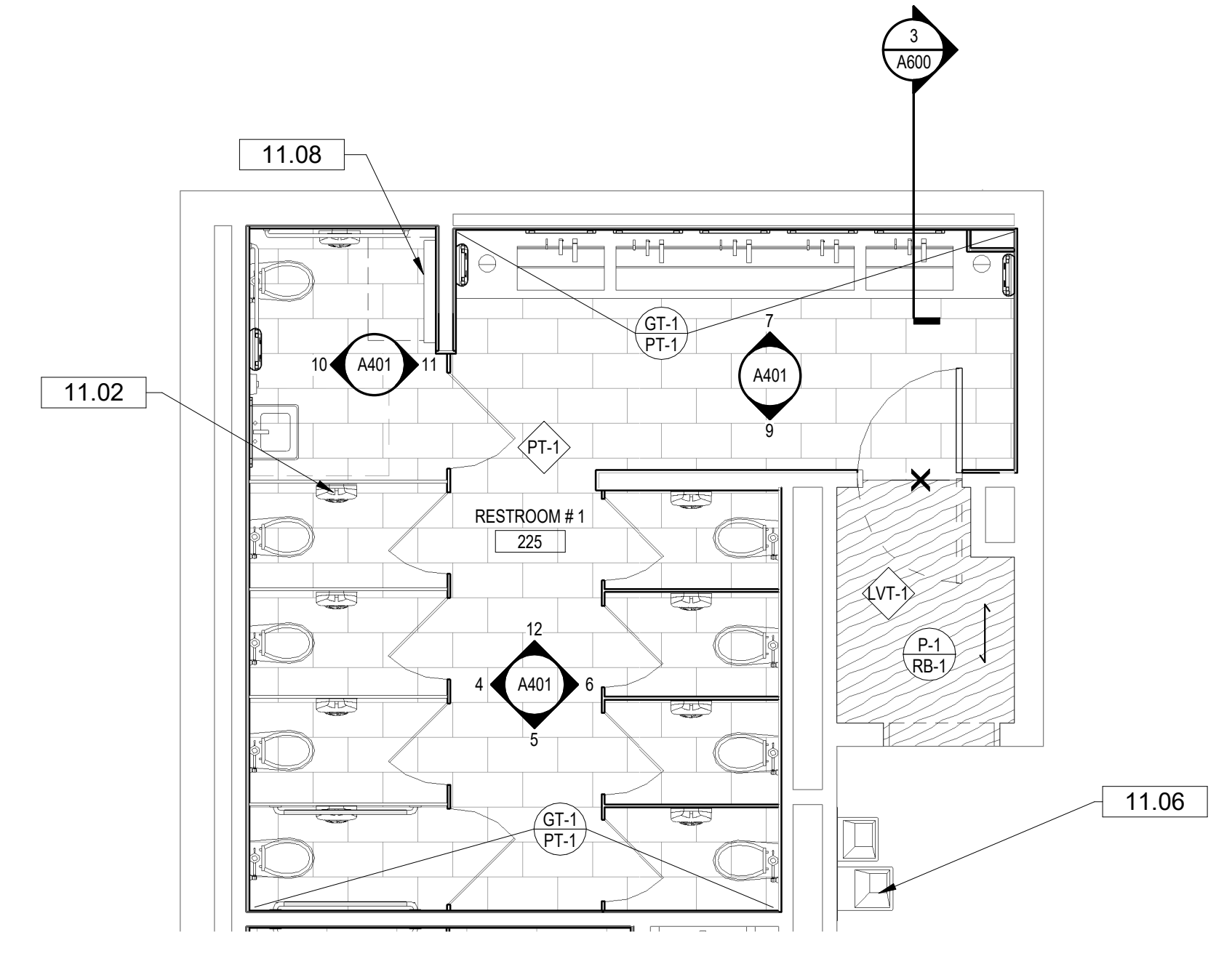

2 FINISH PLAN - RESTROOM 1
 SCALE: 1/4" = 1'-0"

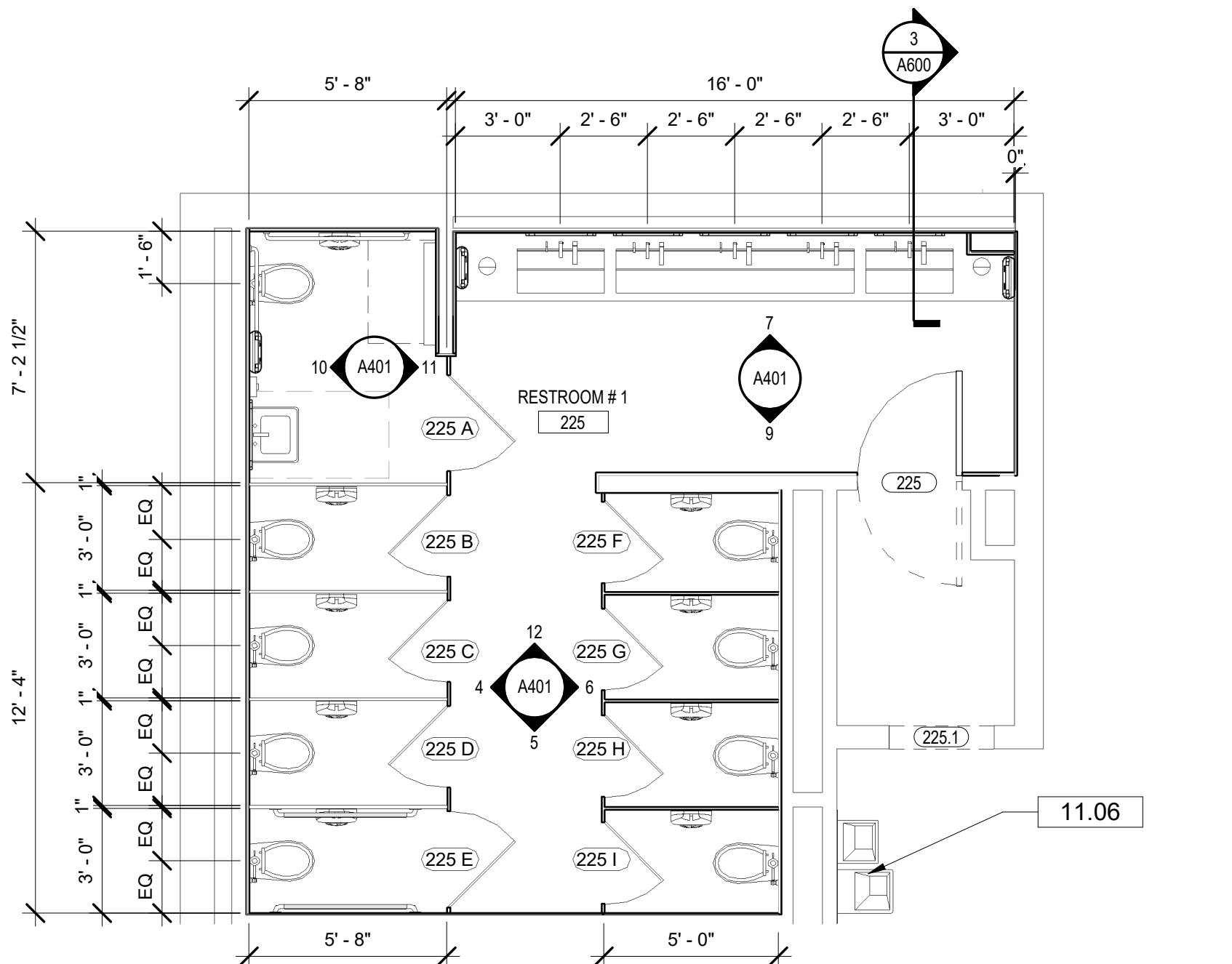

1 DIMENSION PLAN - RESTROOM 1
 SCALE: 1/4" = 1'-0"

REVISIONS:

No.	Description	Date

ENLARGED PLAN - RESTROOM 1

Project number	17057.5
Dated	JANUARY 2019
PIC	Approver
PM	Designer

A401
 Scale As indicated

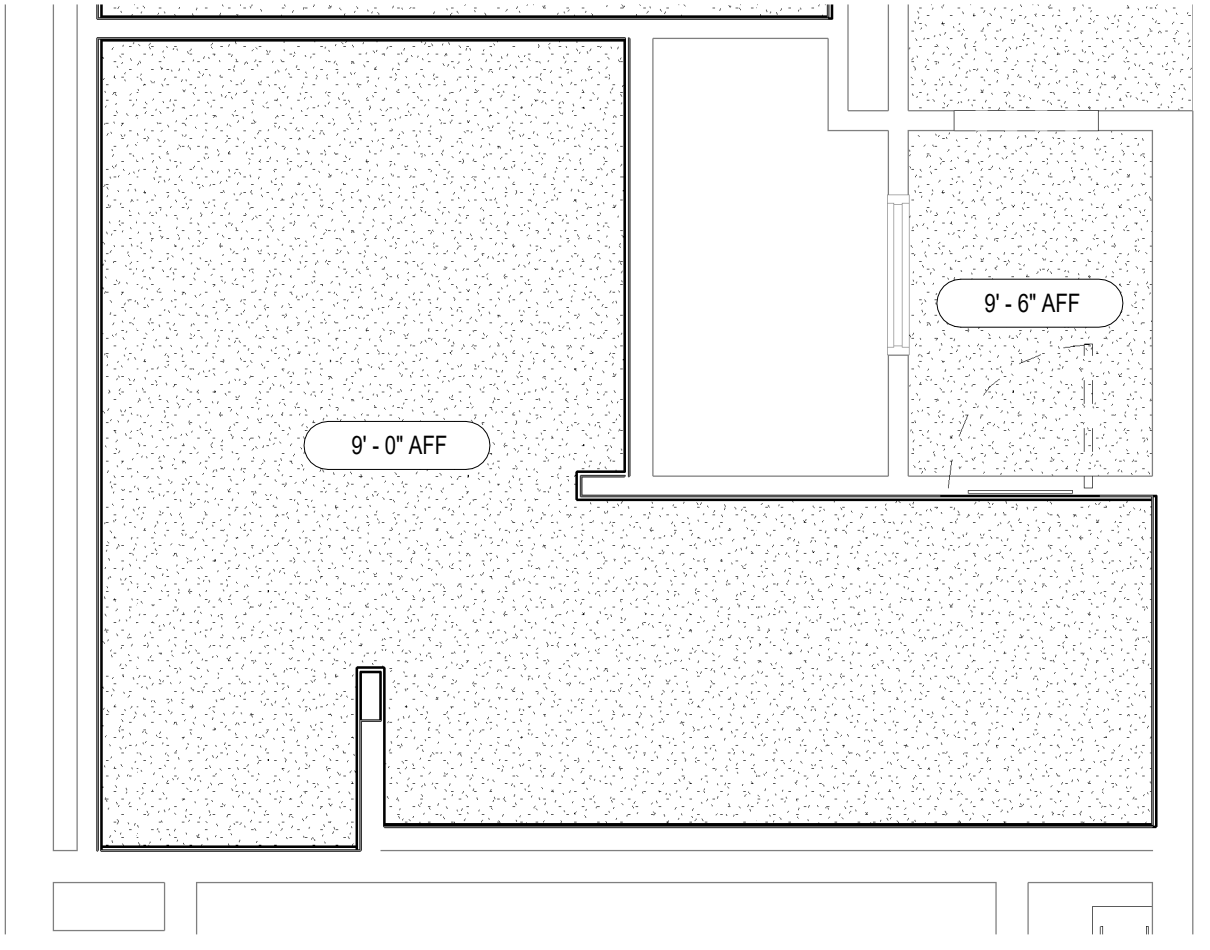

3 LVL 01 RCP - RESTROOM 2
 SCALE: 1/4" = 1'-0"

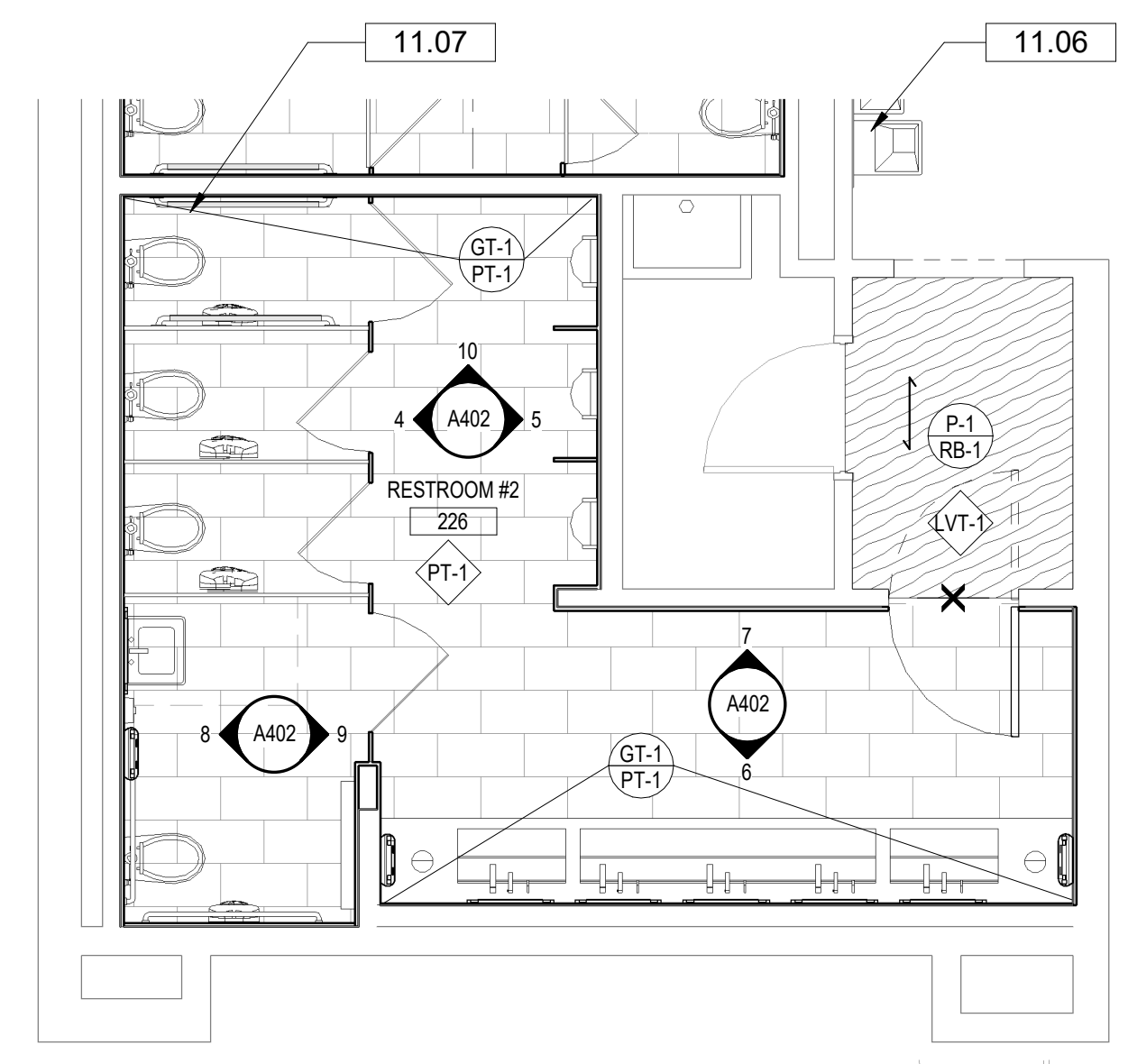

2 FINISH PLAN - RESTROOM 2
 SCALE: 1/4" = 1'-0"

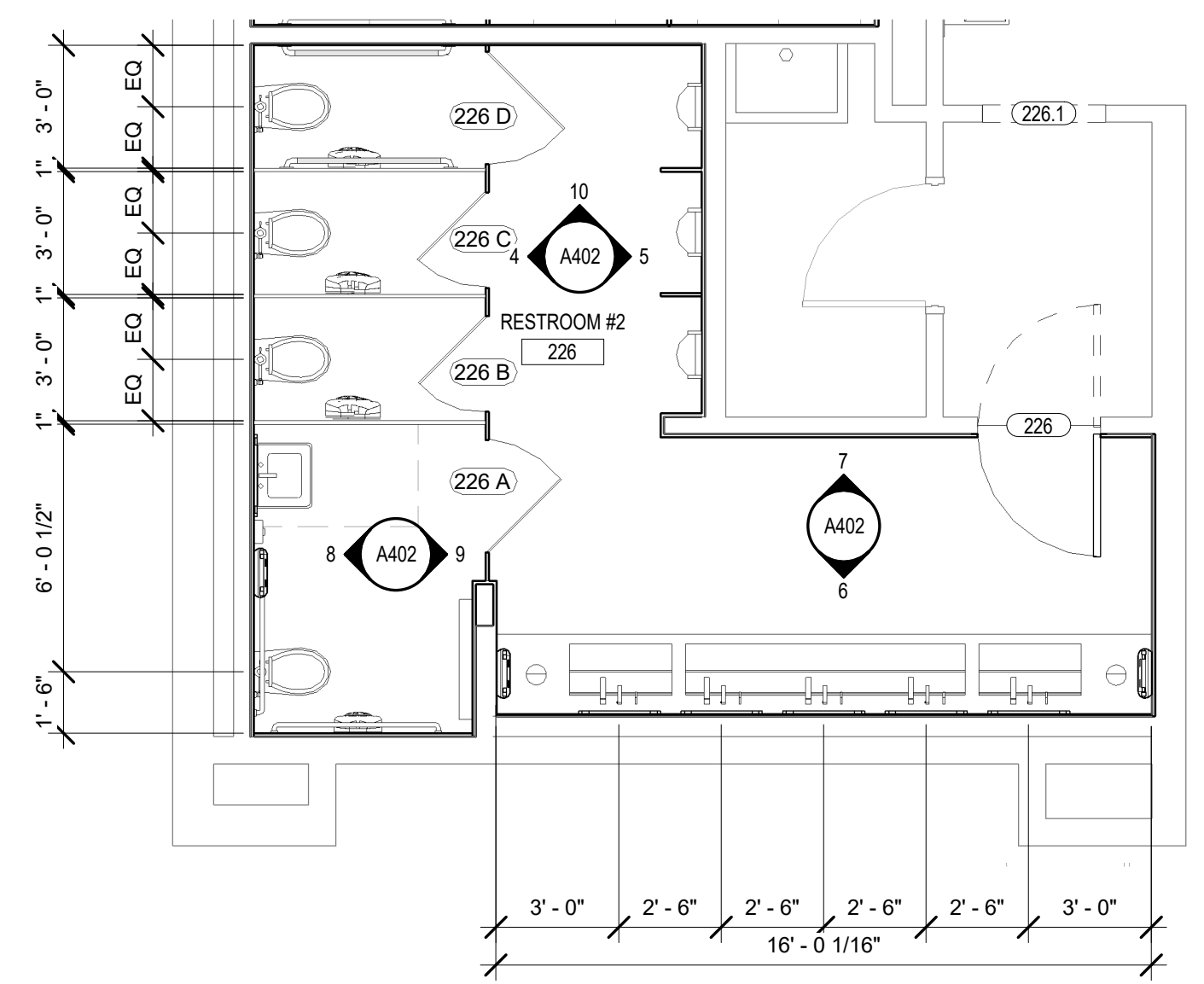

1 DIMENSION PLAN - RESTROOM 2
 SCALE: 1/4" = 1'-0"

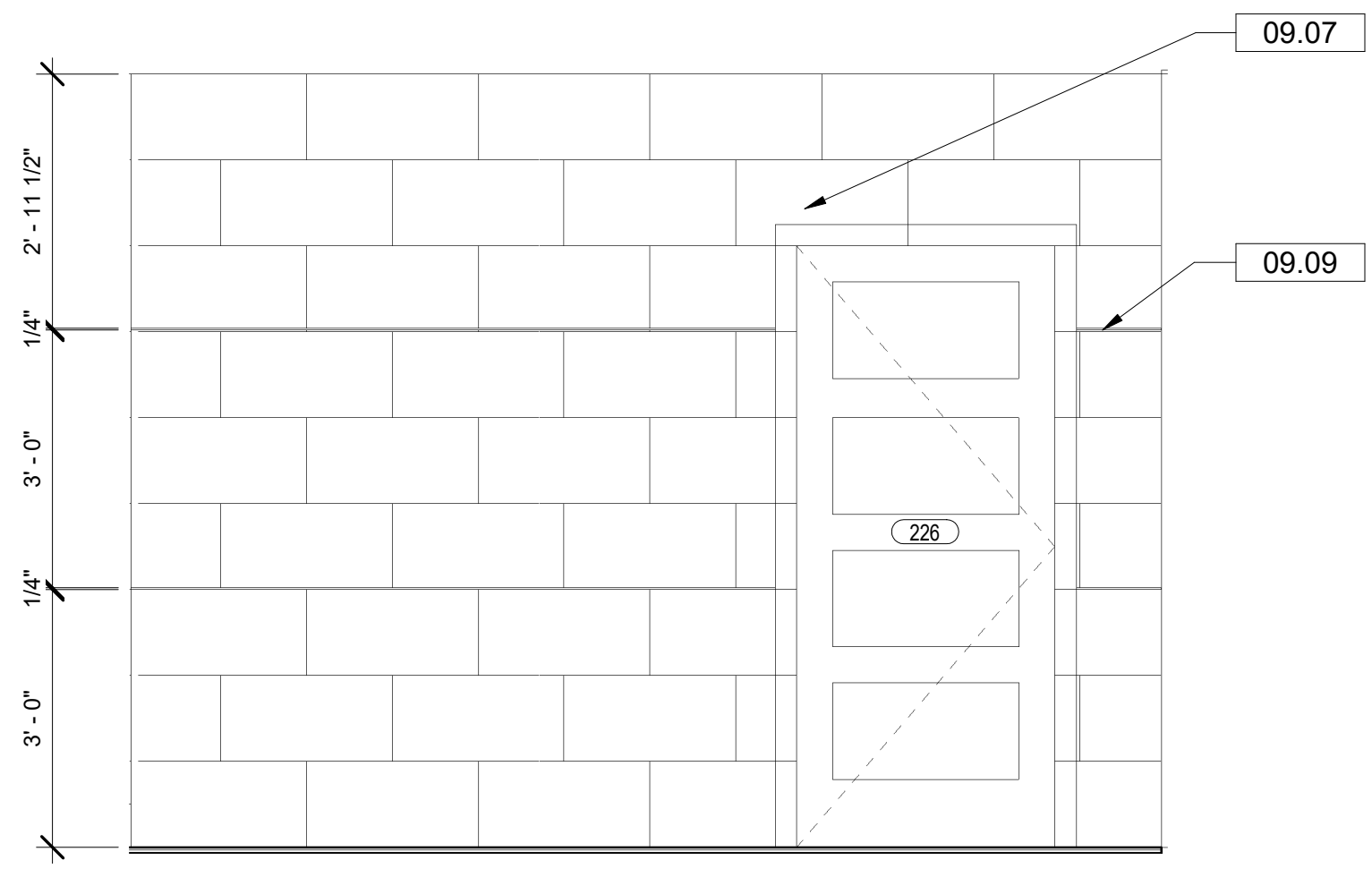

7 RESTROOM 2 - N. ELEV. a
 SCALE: 1/2" = 1'-0"

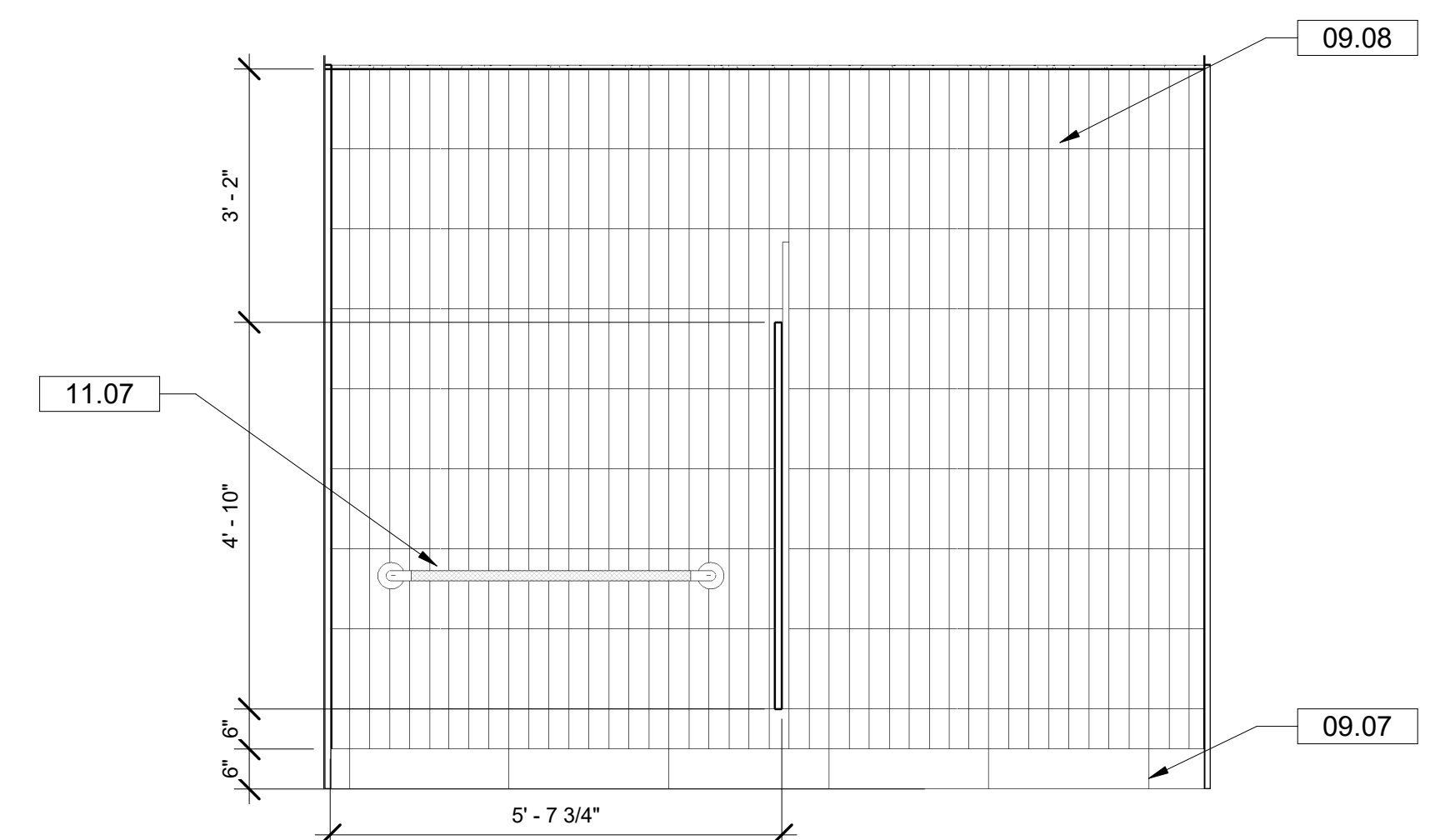

10 RESTROOM 2 - N. ELEV. b
 SCALE: 1/2" = 1'-0"

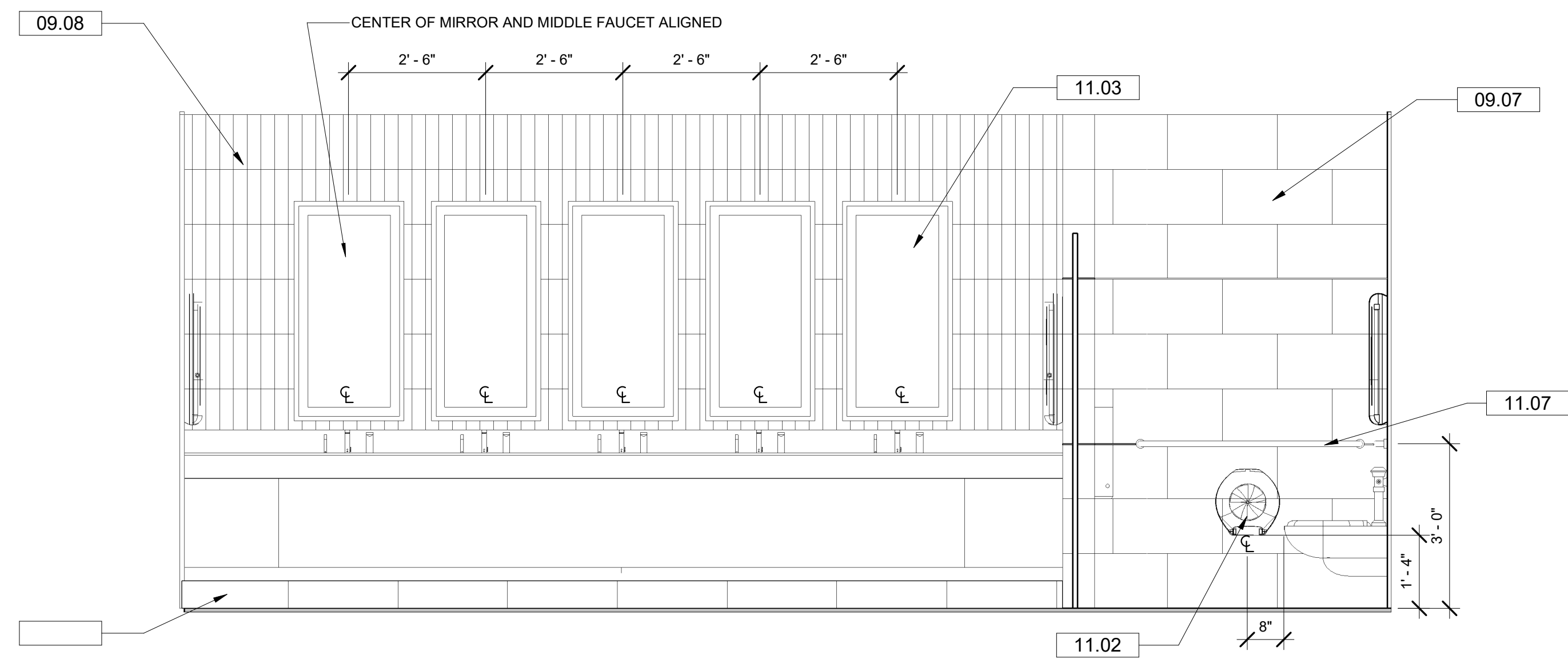

6 RESTROOM 2 - S. ELEV.
 SCALE: 1/2" = 1'-0"

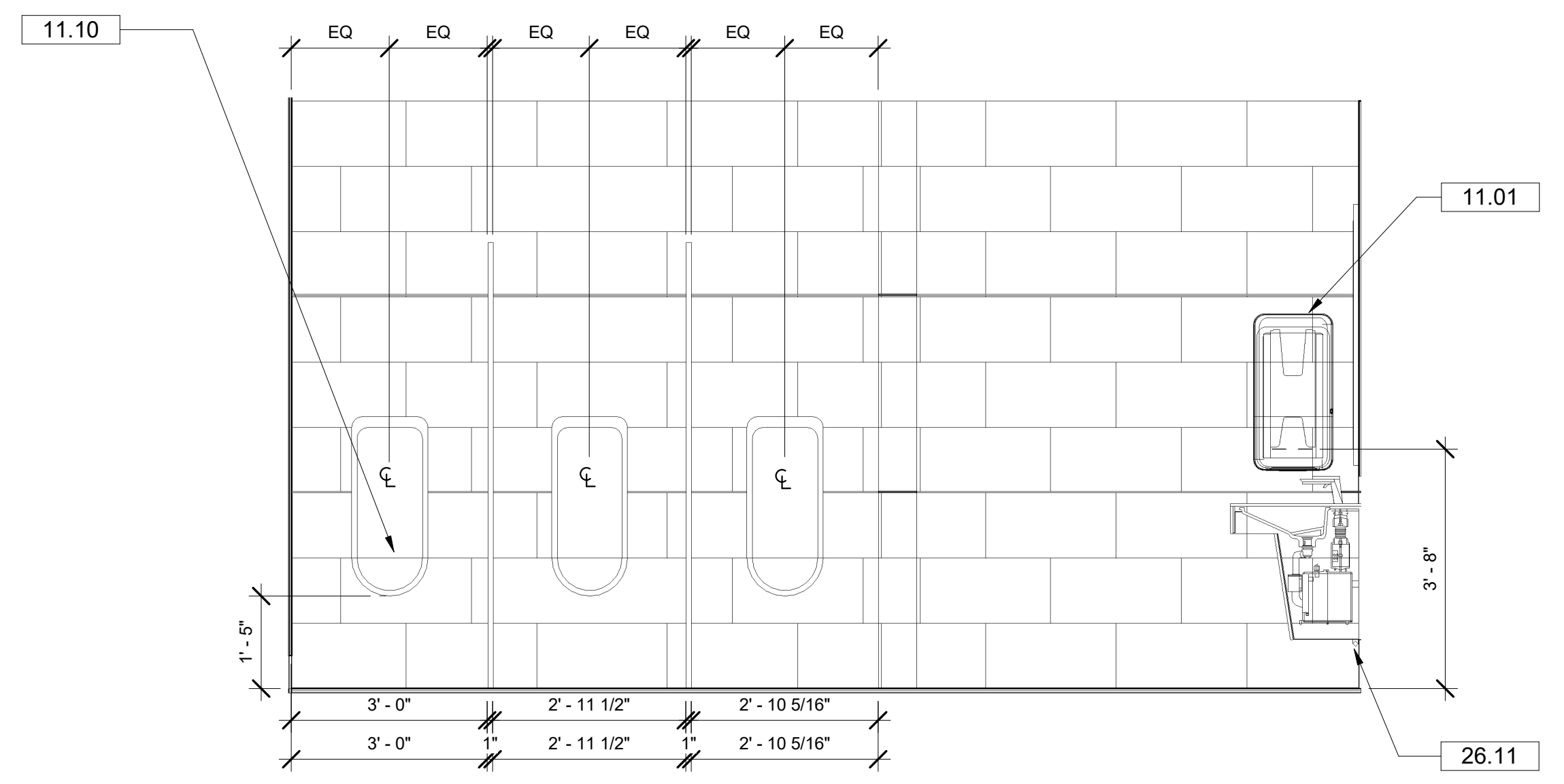

5 RESTROOM 2 - E. ELEV a
 SCALE: 1/2" = 1'-0"

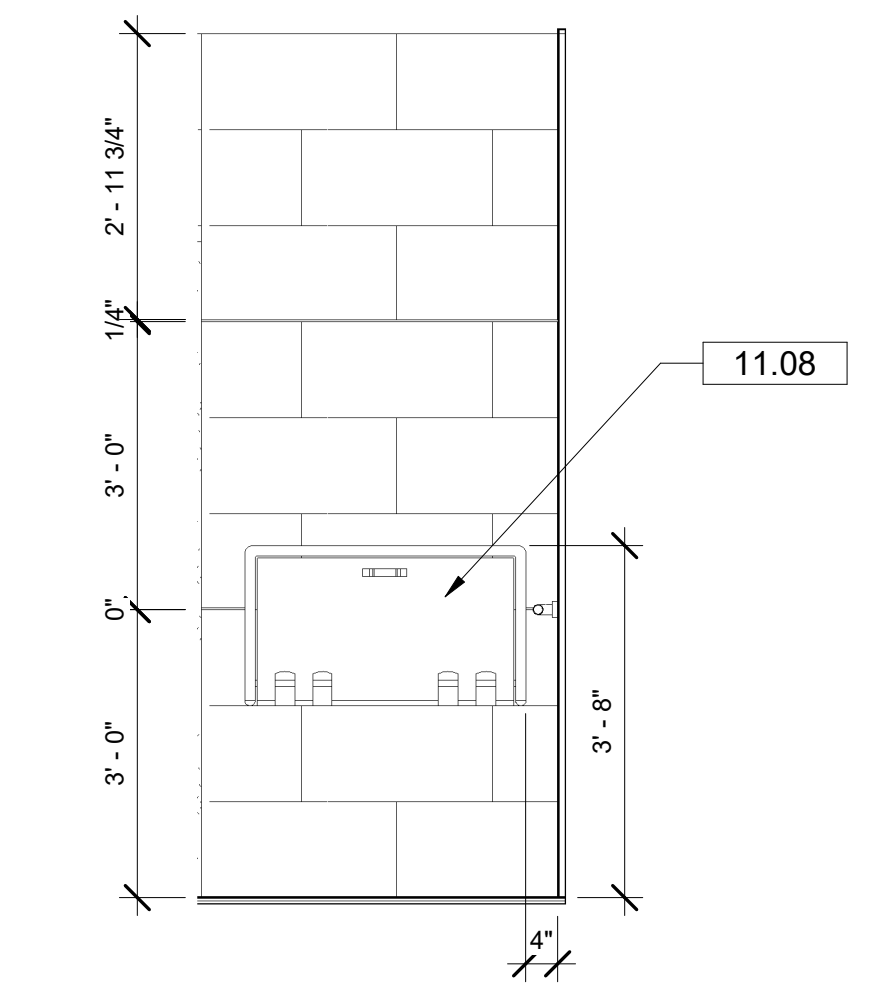

9 RESTROOM 2 - E. ELEV b
 SCALE: 1/2" = 1'-0"

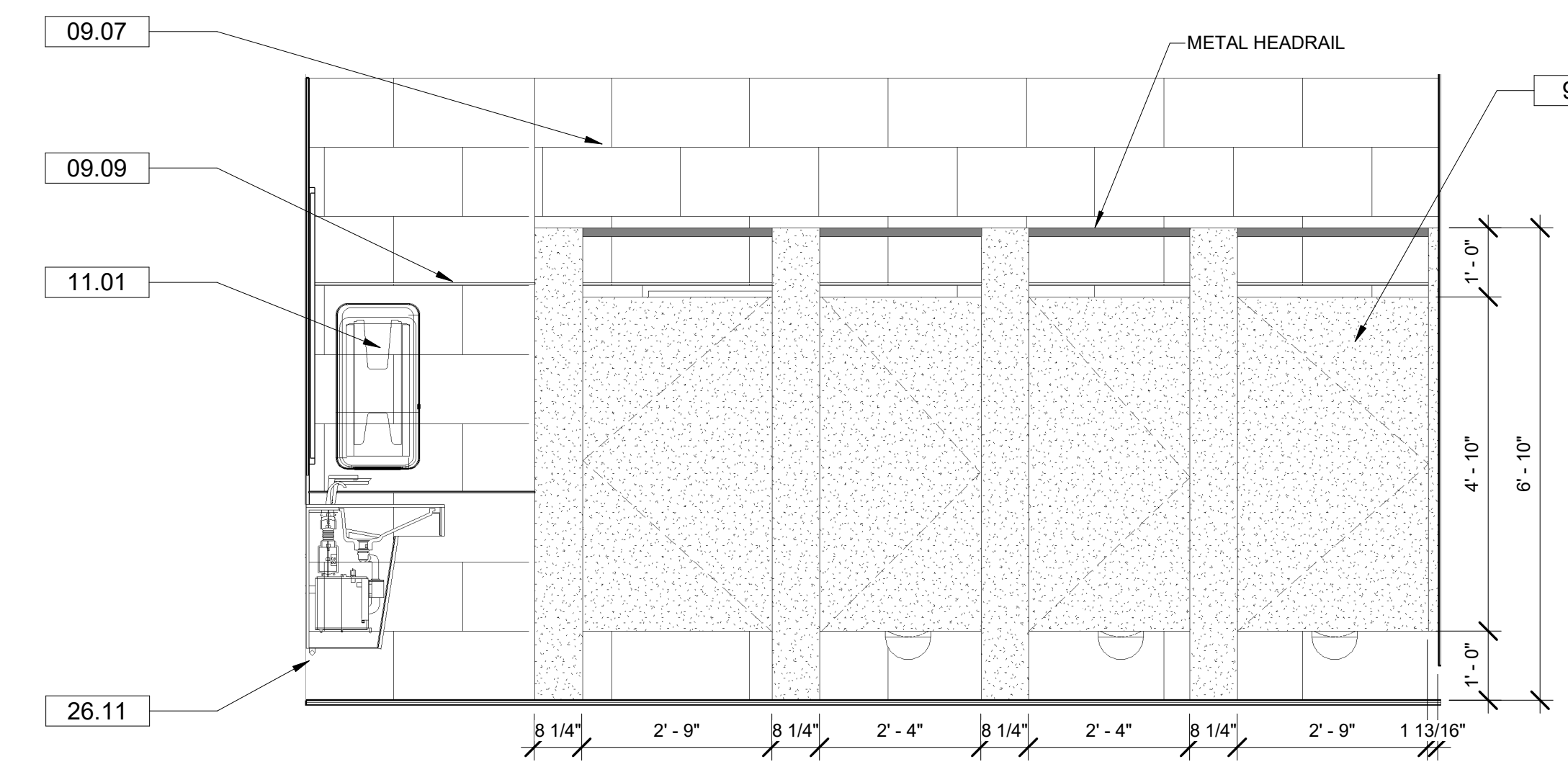

4 RESTROOM 2 - W. ELEV b
 SCALE: 1/2" = 1'-0"

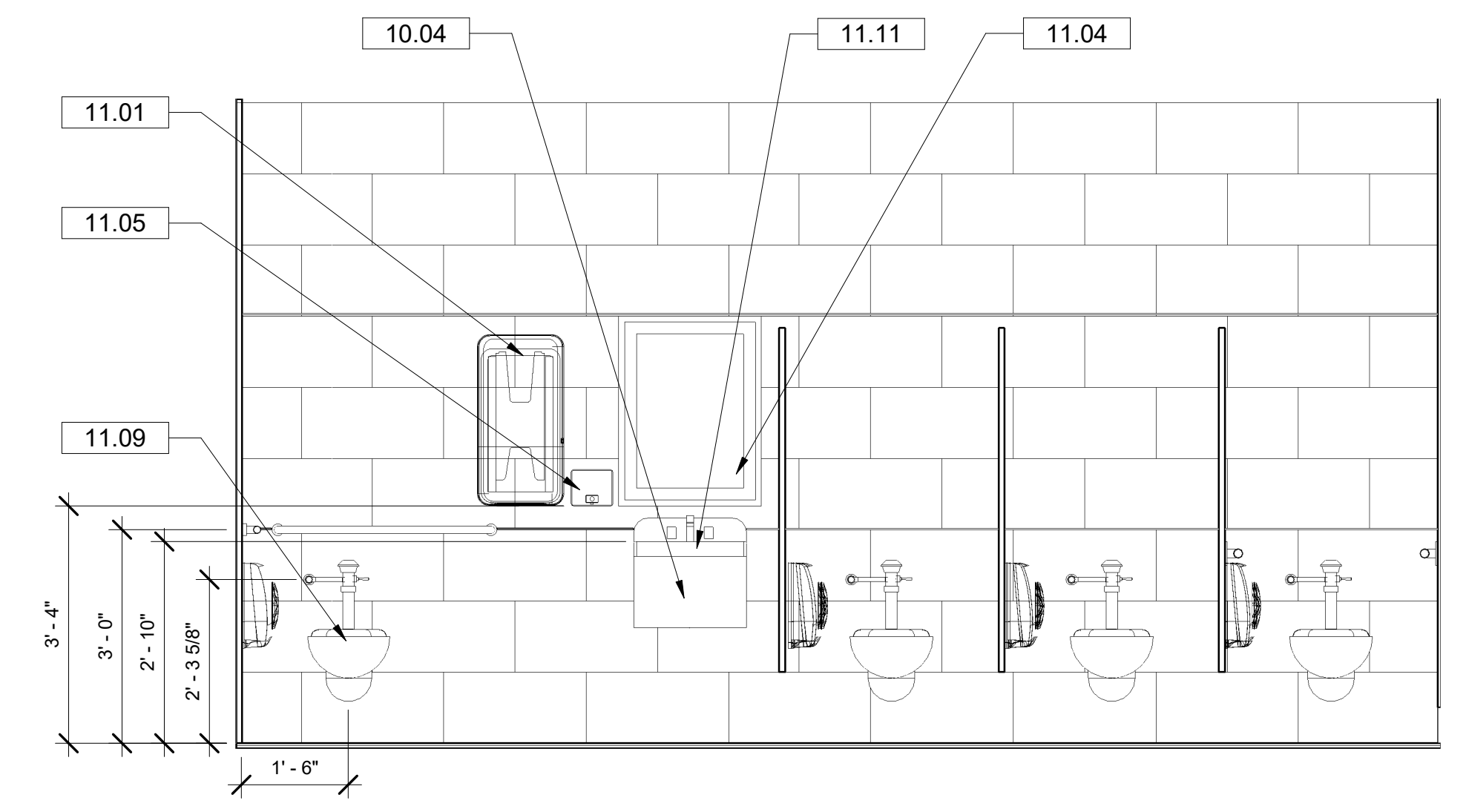

8 RESTROOM 2 - W. ELEV a
 SCALE: 1/2" = 1'-0"

GEN. NOTES: ENLG. PLAN

- FIELD VERIFY ALL EXISTING CONDITIONS PRIOR TO PERFORMING NEW WORK.
- THE CONTRACTOR SHALL PROVIDE REINFORCING BEHIND WALL MOUNTED AND CEILING MOUNTED EQUIPMENT.
- CONTRACTOR SHALL COORDINATE WORK WITH MECHANICAL, ELECTRICAL AND PLUMBING DRAWINGS.
- REFER TO FINISH LEGEND ON SHEET A400 FOR MORE INFORMATION ABOUT FINISHES SHOWN ON THIS SHEET.
- PROVIDE POSITIVE SLOPE TOWARDS ALL FLOOR DRAINS.
- ALL BATHROOM STALLS ARE TO BE COMPOSITE STONE-PLY TOILET COMPARTMENT SYSTEM WITH EQTZ-1 VENEER. INSTALL PER MANUFACTURER'S RECOMMENDATIONS.
- STALL DOORS SHOWN IN ENLARGED FLOORPLANS AS A-H FOR PARTITION HARDWARE COORDINATION ONLY. NOT RELEVANT TO DOOR SCHEDULE.

GENERAL NOTES: RCP

- SEE SHEET A400 FOR ROOM FINISH SCHEDULE FOR ADDITIONAL INFORMATION.
- ALL ACCESS PANEL LOCATIONS TO BE COORDINATED WITH MECHANICAL, ELECTRICAL, PLUMBING AND FIRE SPRINKLER WORK.
- REPLACE CEILINGS AT NEW HEIGHT IN RESTROOMS #1 TO #6. UPGRADING FIXTURES WHERE POSSIBLE.
- SEE ELECTRICAL FOR LIGHTING FIXTURE SCHEDULE. WHERE APPLICABLE, ALL FIRE SPRINKLER HEADS AND ELECTRICAL FIXTURES SHALL BE CENTERED WITHIN CEILING TILES.
- IF ANY ITEMS INDICATED ON THE DRAWINGS ARE IN CONFLICT WITH ONE ANOTHER, CONTRACTOR IS RESPONSIBLE FOR BRINGING TO ARCHITECT FOR FURTHER CLARIFICATION ON DESIGN INTENT.

KEYNOTES

NUMBER	DESCRIPTION
09.07	PT-1 PORCELAIN TILE: PORCELANOSA AVENUE GREY, 12X24, FINISH LAPPATO
09.08	GT-1 GLASS TILE: BODESI HAND PAINTED GLASS TILE, 4X12 CUSTOM COLOR
09.09	GT-2 GLASS PENCIL LINER: ELIDA CERAMICA 12X0.51, GLOSSY (OR SIMILAR)
9.12	EQTZ-1 ENGINEERED QUARTZ: SILESTONE, ETERNAL CALACATTA CLASSIC, POLISHED
10.04	RAKKS EHV-VANITY SUPPORT BRACKET SINK SURROUND (ADA INSTALLMENT AROUND SINK) CORIAN SOLID SURFACE PANELS
11.01	TORK HAND TOWEL DISPENSER, 662520, WHITE; OWNER PROVIDED, CONTRACTOR INSTALLED
11.02	TORK 3 ROLL BATH TISSUE ROLL DISPENSER, 665828, WHITE; OWNER PROVIDED, CONTRACTOR INSTALLED
11.03	MIRROR: PARIS MIRROR: LIGHTED MIRROR HARMONY: 24X48" LED 110V WIRING
11.04	MIRROR: PARIS MIRROR: LIGHTED MIRROR HARMONY: 24X32" LED 110V WIRING
11.05	SD SOAP DISPENSER; OWNER PROVIDED, CONTRACTOR INSTALLED
11.06	WATER COOLER SPECIFIED BY WATERFORD PLUMBING ENGINEER
11.07	GB GRAB BAR (ADA HEIGHT) MOUNTED BETWEEN 33-36" AFF
11.08	CHANGING TABLE: KOALA KARE KB200-05, WHITE GRANITE MOUNTED 2' AFF
11.09	ADA ADULT TOILET (WALL MOUNTED)
11.10	ADA ADULT URINAL (WALL-MOUNTED)
11.11	ADA SINK SPECIFIED BY WATERFORD PLUMBING ENGINEER
26.11	LED LIGHTING UNDER SINK SYSTEM (ATTACHMENT NOT INCLUDED WITH SINK SYSTEM)



OWNERSHIP OF SERVICE
 ALL REPORTS, PLANS, SPECIFICATIONS, COMPUTER FILES, FIELD DATA, NOTES AND OTHER DOCUMENTS AND INSTRUMENTS PREPARED BY THE CONSULTANT AS AN INSTRUMENT OF SERVICES SHALL REMAIN THE PROPERTY OF THE CONSULTANT. THE CONSULTANT SHALL RETAIN ALL COMMON LAW, STATUTORY AND OTHER RESERVED RIGHTS, INCLUDING THE COPYRIGHT THERE TO.

PURSUANT TO FLORIDA STATUTES, SECTION 550.003, AN INDIVIDUAL EMPLOYEE OR AGENT MAY NOT BE HELD INDIVIDUALLY LIABLE FOR NEGLIGENCE.

BID DOCUMENTS

EMERALD COAST CONVENTION CENTER
RESTROOM RENOVATIONS & MEETING ROOM COUNTERS
 TASK ORDER NO. 5 - C-18-2638-TDD
 1250 MIRACLE STRIP PKWY SE
 FORT WALTON BEACH, FL 32548

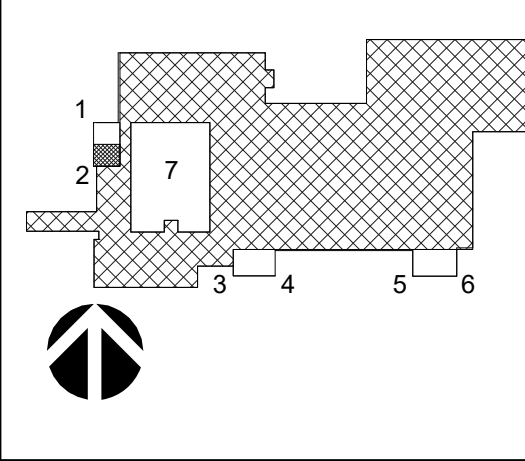

REVISIONS:

No.	Description	Date

ENLARGED PLAN- RESTROOM 2

Project number **17057.5**
 Dated **JANUARY 2019**
 PIC **Approver**
 PM **Designer**

A402
 Scale **As indicated**

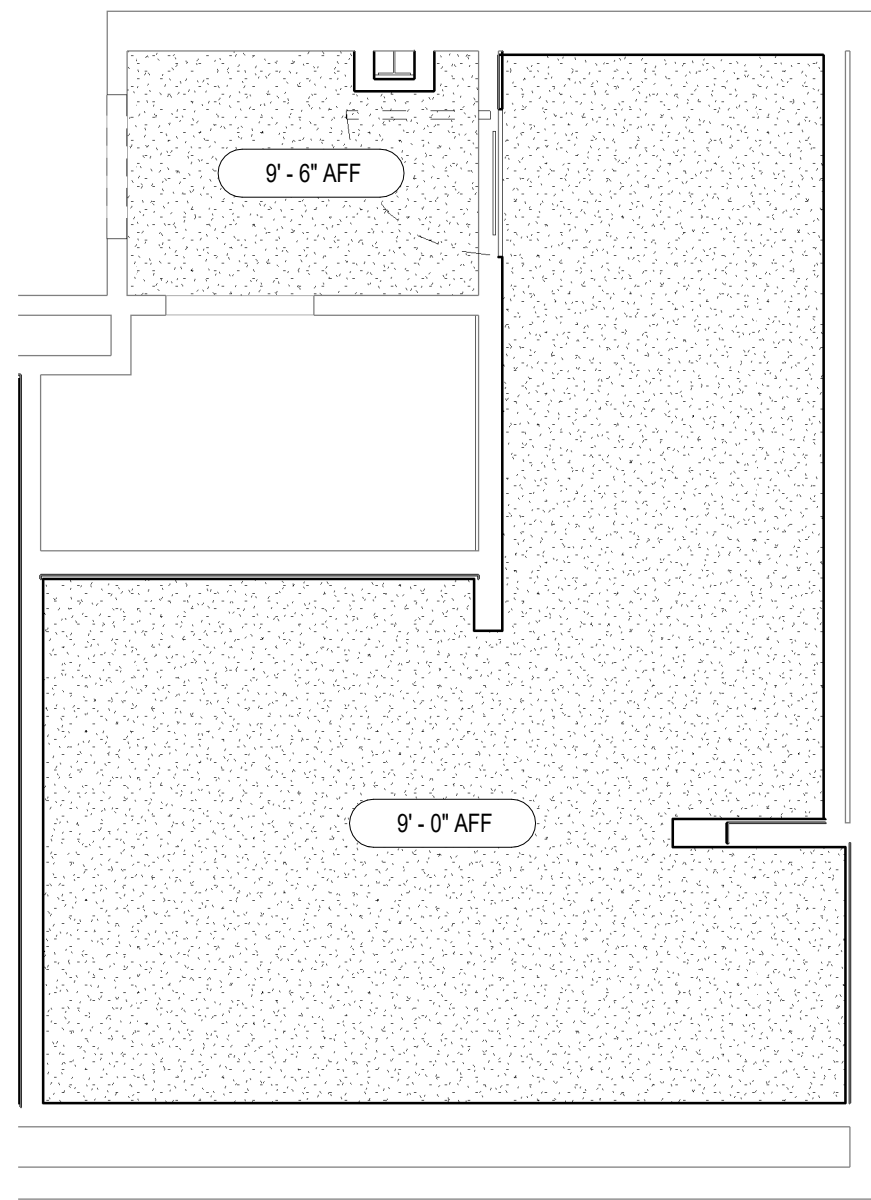

3 LVL 01 RCP - RESTROOM 4
 SCALE: 1/4" = 1'-0"

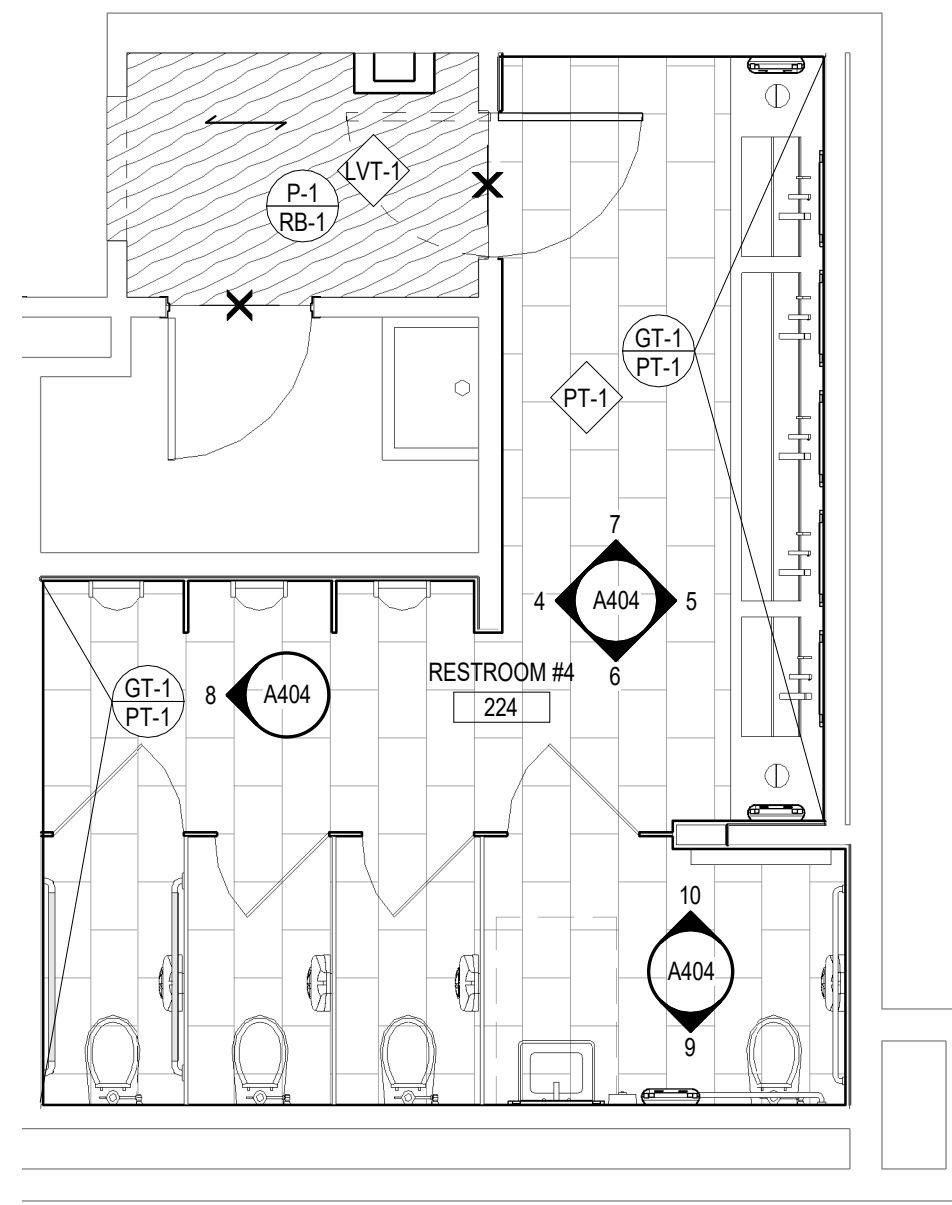

2 FINISH PLAN - RESTROOM 4
 SCALE: 1/4" = 1'-0"

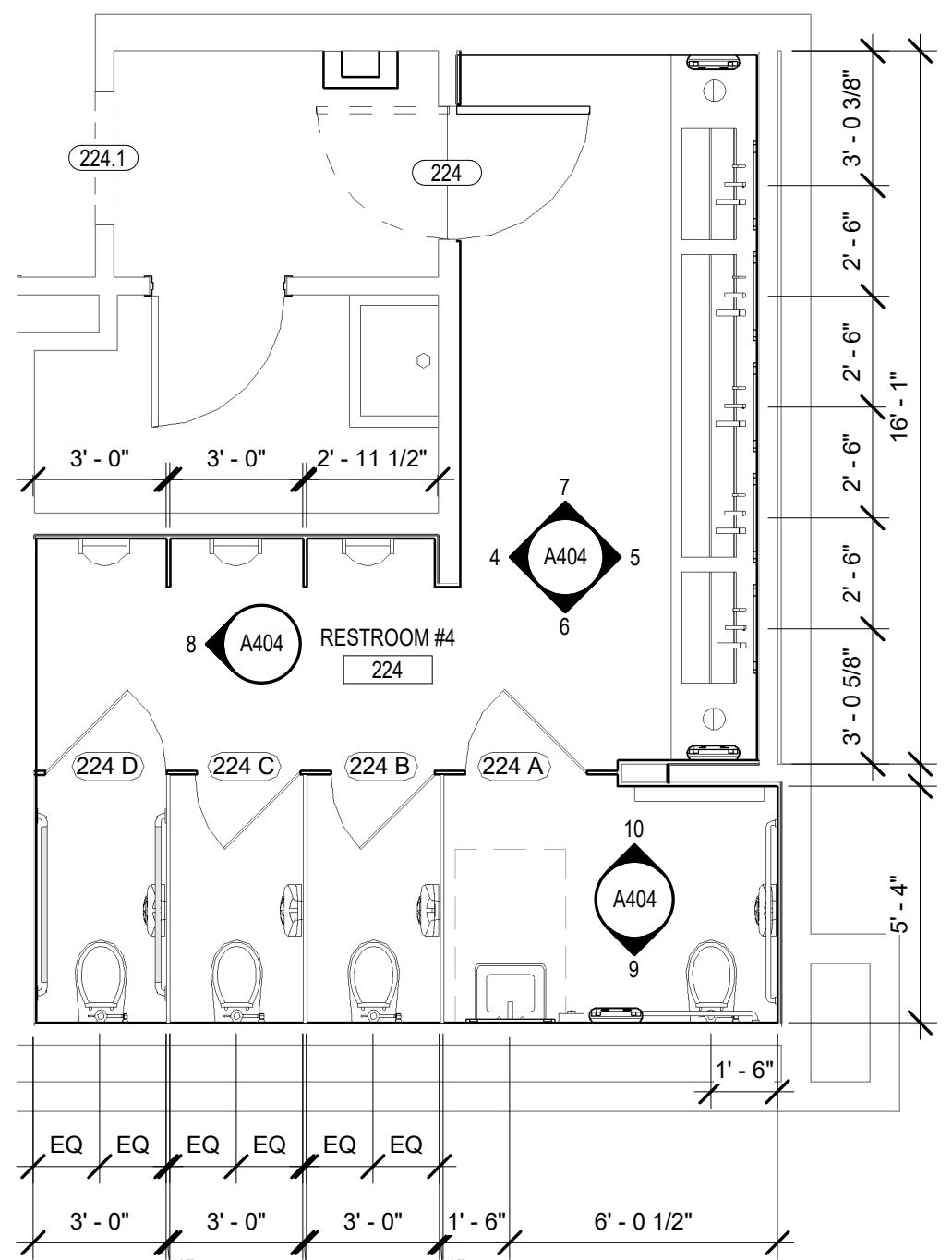

1 DIMENSION PLAN - RESTROOM 4
 SCALE: 1/4" = 1'-0"

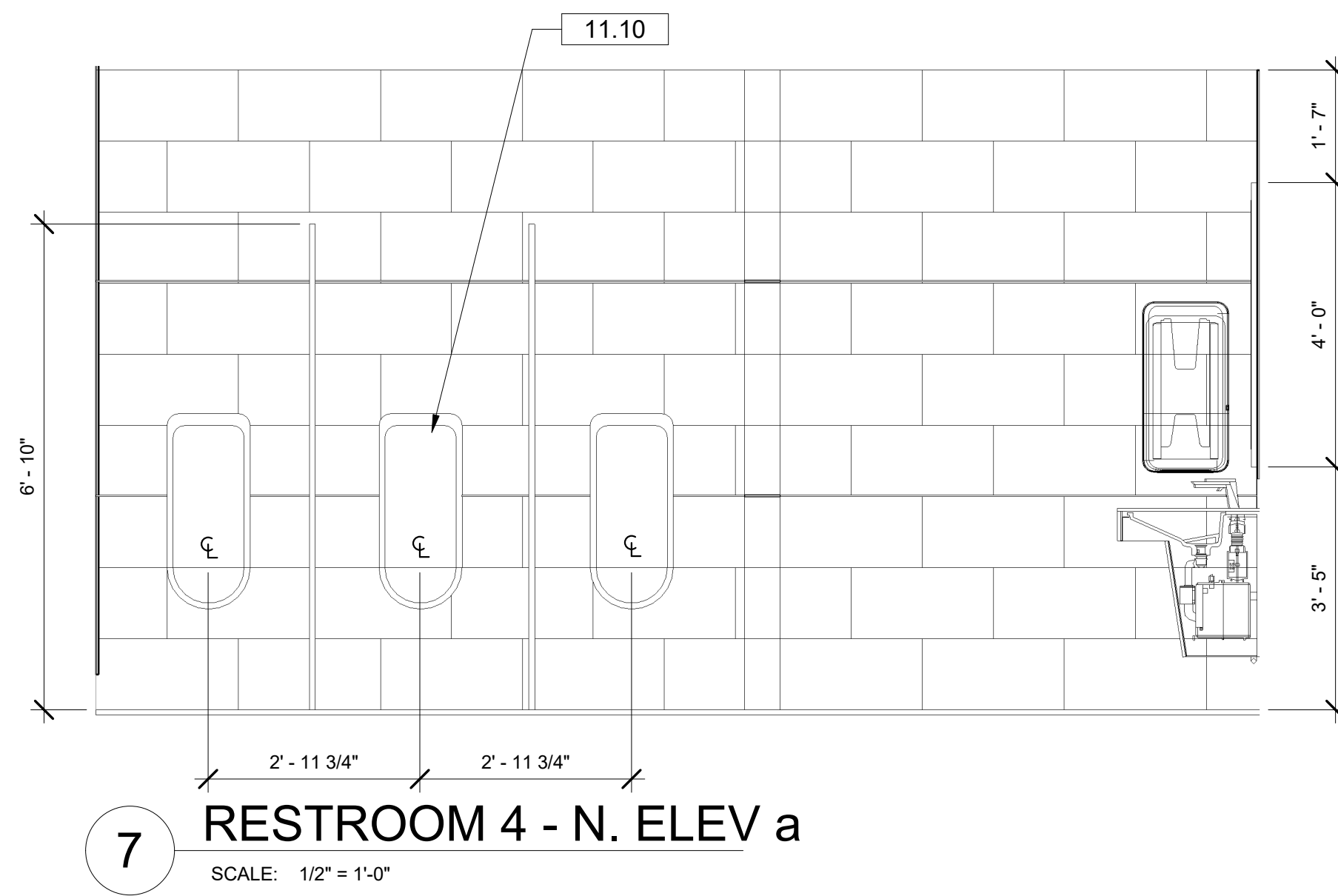

7 RESTROOM 4 - N. ELEV a
 SCALE: 1/2" = 1'-0"

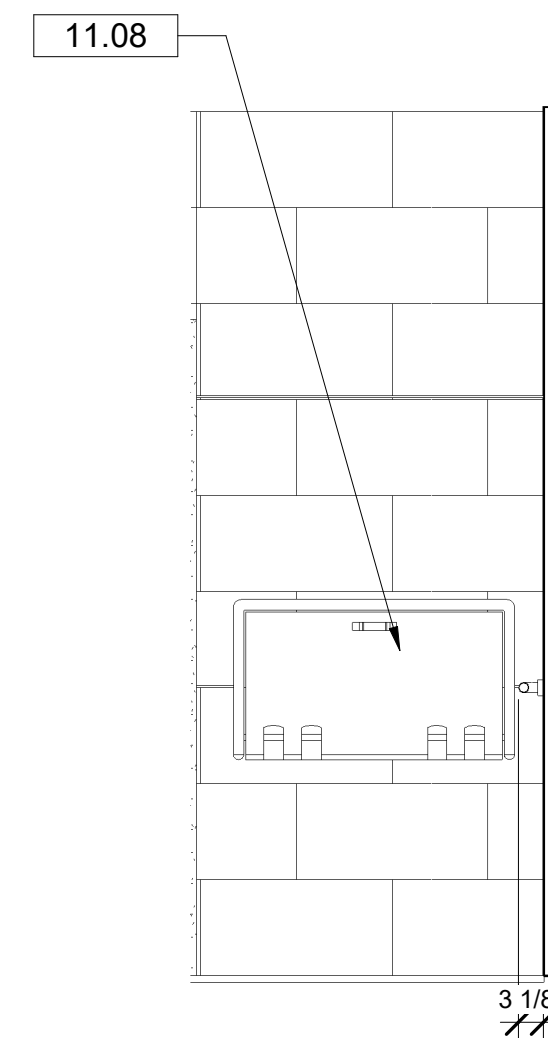

10 RESTROOM 4 - N. ELEV b
 SCALE: 1/2" = 1'-0"

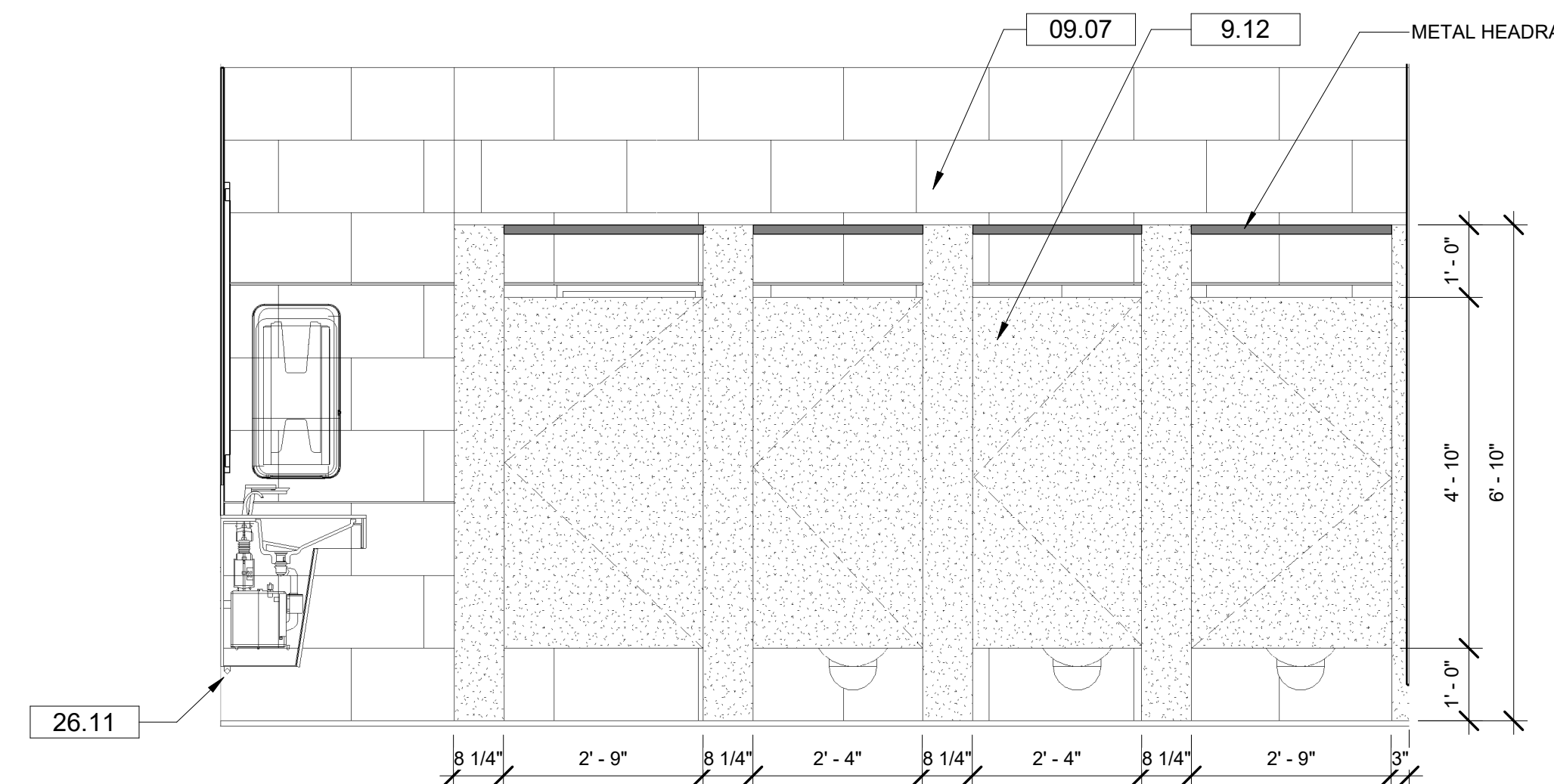

6 RESTROOM 4 - S. ELEV a
 SCALE: 1/2" = 1'-0"

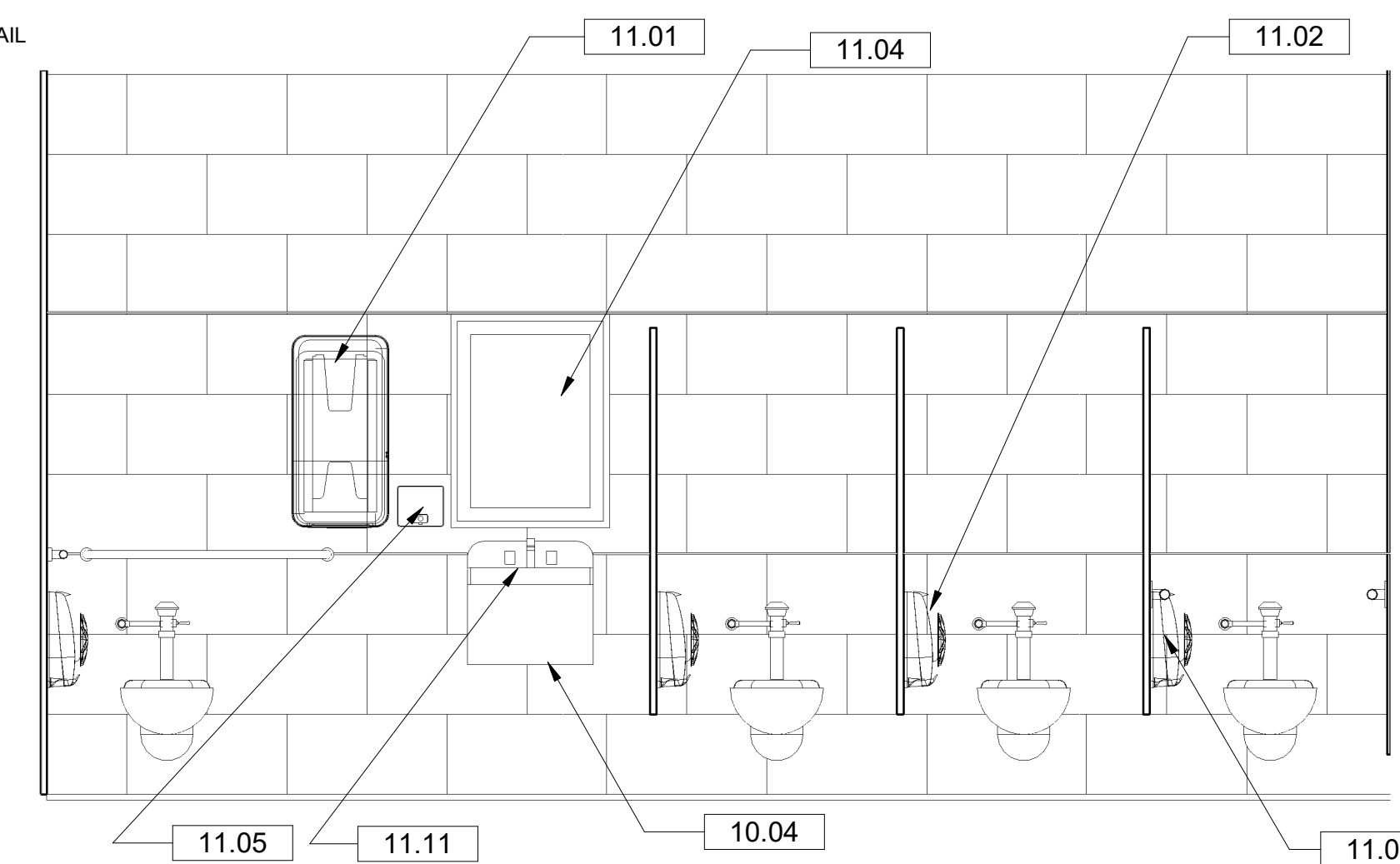

9 RESTROOM 4 - S. ELEV b
 SCALE: 1/2" = 1'-0"

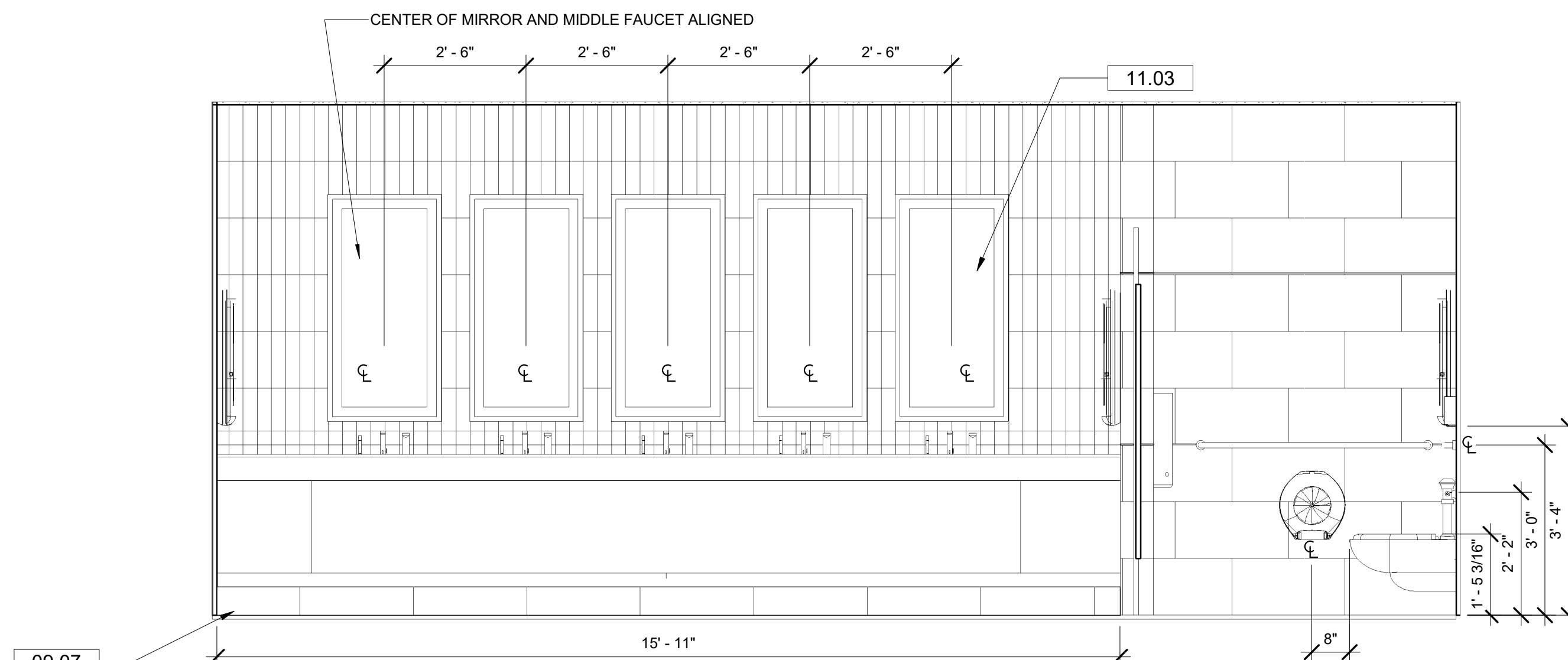

5 RESTROOM 4 - E. ELEV
 SCALE: 1/2" = 1'-0"

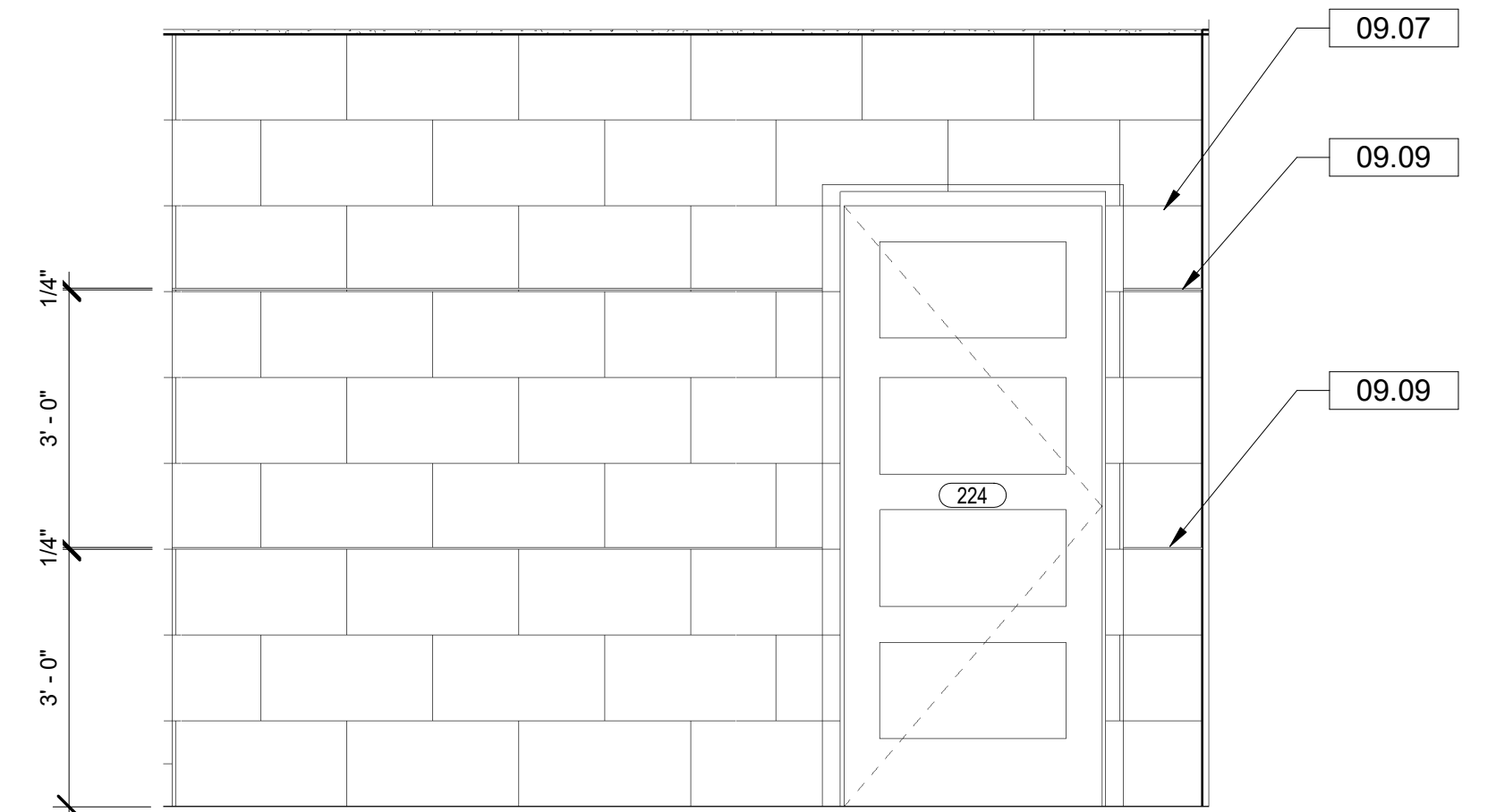

4 RESTROOM 4 - W. ELEV a
 SCALE: 1/2" = 1'-0"

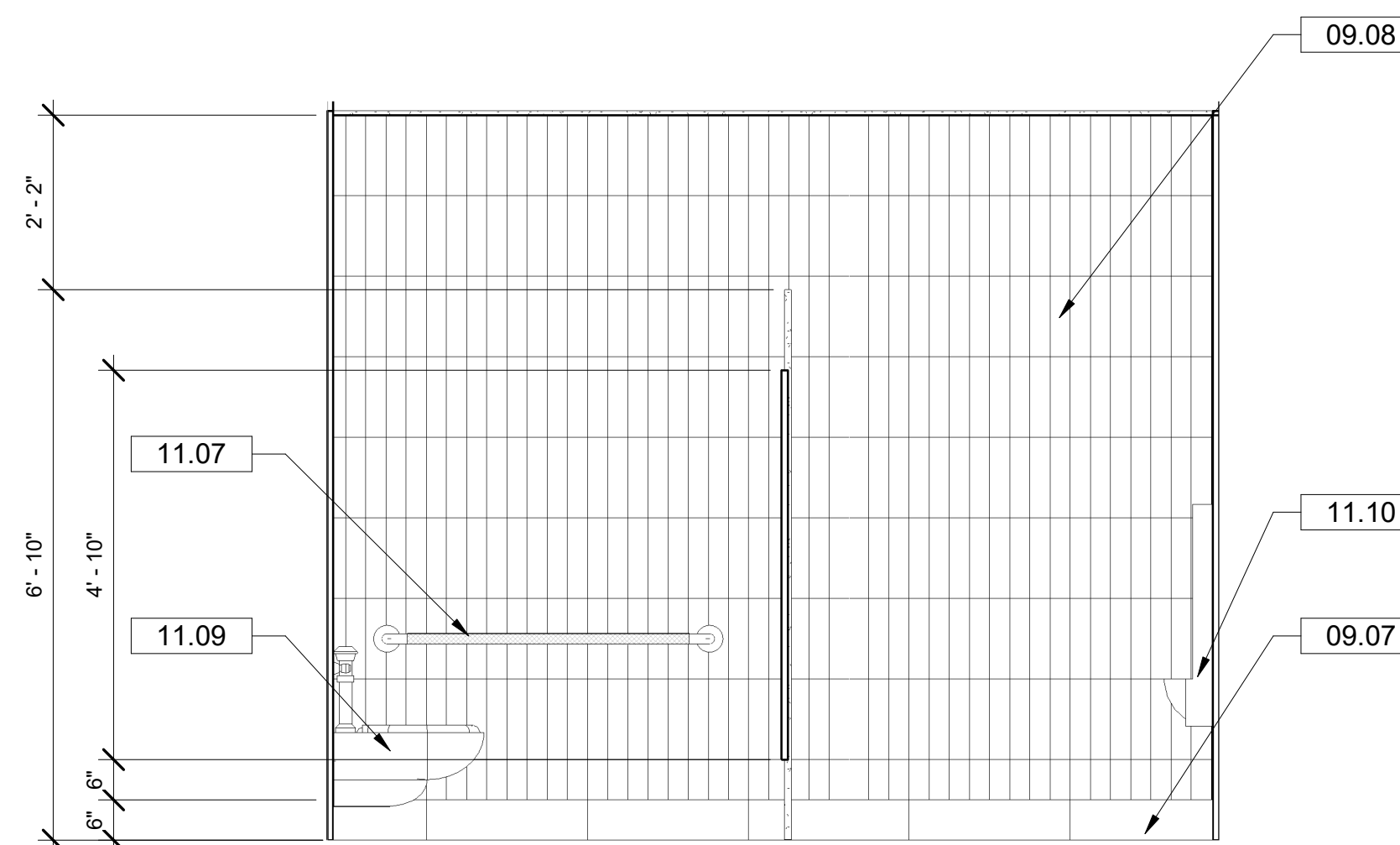

8 RESTROOM 4 - W. ELEV b
 SCALE: 1/2" = 1'-0"

GEN. NOTES: ENLG. PLAN

1. FIELD VERIFY ALL EXISTING CONDITIONS PRIOR TO PERFORMING NEW WORK.
2. THE CONTRACTOR SHALL PROVIDE REINFORCING BEHIND WALL MOUNTED AND CEILING MOUNTED EQUIPMENT.
3. CONTRACTOR SHALL COORDINATE WORK WITH MECHANICAL, ELECTRICAL AND PLUMBING DRAWINGS.
4. REFER TO FINISH LEGEND ON SHEET A400 FOR MORE INFORMATION ABOUT FINISHES SHOWN ON THIS SHEET.
5. PROVIDE POSITIVE SLOPE TOWARDS ALL FLOOR DRAINS.
6. ALL BATHROOM STALLS ARE TO BE COMPOSITE STONE-FLY TOILET COMPARTMENT SYSTEM WITH EOTZ-1 VENEER. INSTALL PER MANUFACTURER'S RECOMMENDATIONS.
7. STALL DOORS SHOWN IN ENLARGED FLOORPLANS AS A-H FOR PARTITION HARDWARE COORDINATION ONLY. NOT RELEVANT TO DOOR SCHEDULE.

GENERAL NOTES: RCP

1. SEE SHEET A400 FOR ROOM FINISH SCHEDULE FOR ADDITIONAL INFORMATION.
2. ALL ACCESS PANEL LOCATIONS TO BE COORDINATED WITH MECHANICAL, ELECTRICAL, PLUMBING AND FIRE SPRINKLER WORK.
3. REPLACE CEILING AT NEW HEIGHT IN RESTROOMS #1 TO #6. UPGRADING FIXTURES WHERE POSSIBLE.
4. SEE ELECTRICAL FOR LIGHTING FIXTURE SCHEDULE. WHERE APPLICABLE, ALL FIRE SPRINKLER HEADS AND ELECTRICAL FIXTURES SHALL BE CENTERED WITHIN CEILING TILES.
5. IF ANY ITEMS INDICATED ON THE DRAWINGS ARE IN CONFLICT WITH ONE ANOTHER, CONTRACTOR IS RESPONSIBLE FOR BRINGING TO ARCHITECT FOR FURTHER CLARIFICATION ON DESIGN INTENT.

KEYNOTES

NUMBER	DESCRIPTION
09.07	PT-1 PORCELAIN TILE: PORCELANOSA AVENUE GREY, 12X24, FINISH LAPPATO
09.08	GT-1 GLASS TILE: BODESI HAND PAINTED GLASS TILE, 4X12 CUSTOM COLOR
09.09	GT-2 GLASS PENCIL LINER: ELIDA CERAMICA 12X0.51, GLOSSY (OR SIMILAR)
9.12	EOTZ-1 ENGINEERED QUARTZ: SILESTONE, ETERNAL CALACATTA CLASSIC, POLISHED
10.04	RAKKS EHV-VANITY SUPPORT BRACKET SINK SURROUND (ADA INSTALLMENT AROUND SINK) CORIAN SOLID SURFACE PANELS
11.01	TORK HAND TOWEL DISPENSER, 552520, WHITE; OWNER PROVIDED, CONTRACTOR INSTALLED
11.02	TORK 3 ROLL BATH TISSUE ROLL DISPENSER, 565828, WHITE; OWNER PROVIDED, CONTRACTOR INSTALLED
11.03	MIRROR: PARIS MIRROR: LIGHTED MIRROR HARMONY: 24X48" LED 110V WIRING
11.04	MIRROR: PARIS MIRROR: LIGHTED MIRROR HARMONY: 24X32" LED 110V WIRING
11.05	SD: SOAP DISPENSER; OWNER PROVIDED, CONTRACTOR INSTALLED
11.07	GB: GRAB BAR (ADA HEIGHT) MOUNTED BETWEEN 33-36" AFF
11.08	CHANGING TABLE: KOALA KARE KB200-05, WHITE GRANITE; MOUNTED 24" AFF
11.09	ADA ADULT TOILET (WALL MOUNTED)
11.10	ADA ADULT URINAL (WALL MOUNTED)
11.11	ADA SINK SPECIFIED BY WATERFORD PLUMBING ENGINEER
26.11	LED LIGHTING UNDER SINK SYSTEM (ATTACHMENT NOT INCLUDED WITH SINK SYSTEM)



OWNERSHIP OF SERVICE
 ALL REPORTS, PLANS, SPECIFICATIONS, COMPUTER FILES, FIELD DATA, NOTES AND OTHER DOCUMENTS AND INSTRUMENTS PREPARED BY THE CONSULTANT AS AN INSTRUMENT OF SERVICE SHALL REMAIN THE PROPERTY OF THE CONSULTANT. THE CONSULTANT SHALL RETAIN ALL COMMON LAW, STATUTORY AND OTHER RESERVED RIGHTS, INCLUDING THE COPYRIGHT THERE TO.

PURSUANT TO FLORIDA STATUTES, SECTION 559.003, AN INDIVIDUAL EMPLOYEE OR AGENT MAY NOT BE HELD INDIVIDUALLY LIABLE FOR NEGLIGENCE.

BID DOCUMENTS

**EMERALD COAST CONVENTION CENTER
 RESTROOM RENOVATIONS & MEETING ROOM
 COUNTERS**

TASK ORDER NO. 5 - C-18-2638-TDD
 1250 MIRACLE STRIP PKWY SE
 FORT WALTON BEACH, FL 32548

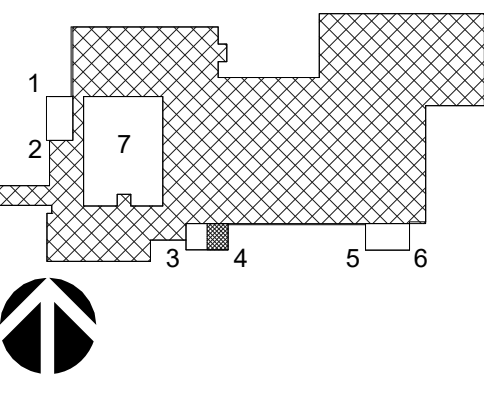

REVISIONS:

No.	Description	Date

**ENLARGED
 PLAN -
 RESTROOM 4**

Project number	17057.5
Dated	JANUARY 2019
PIC	Approver
PM	Designer

A404
 Scale As indicated

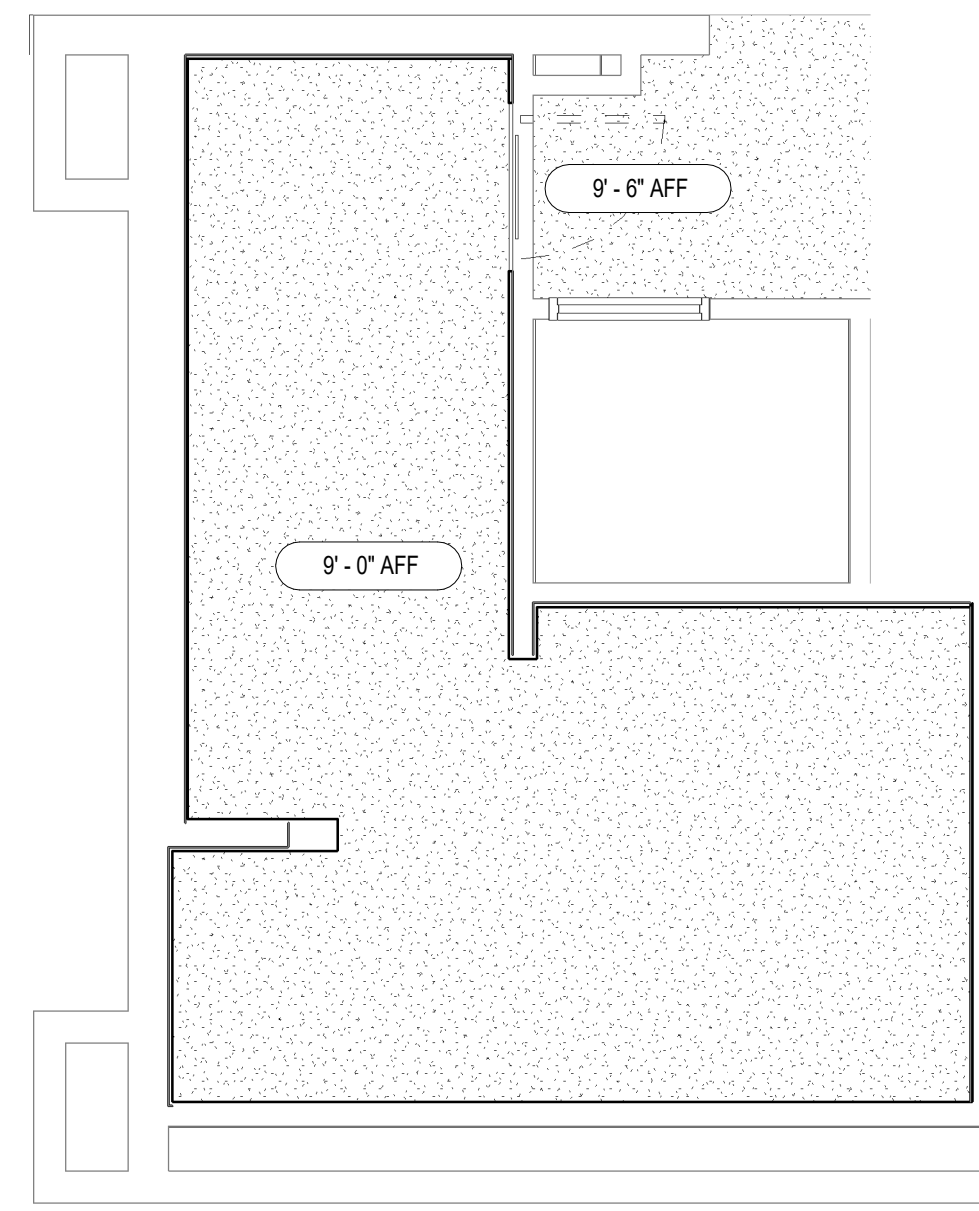

3 LVL 01 RCP - RESTROOM 5
 SCALE: 1/4" = 1'-0"

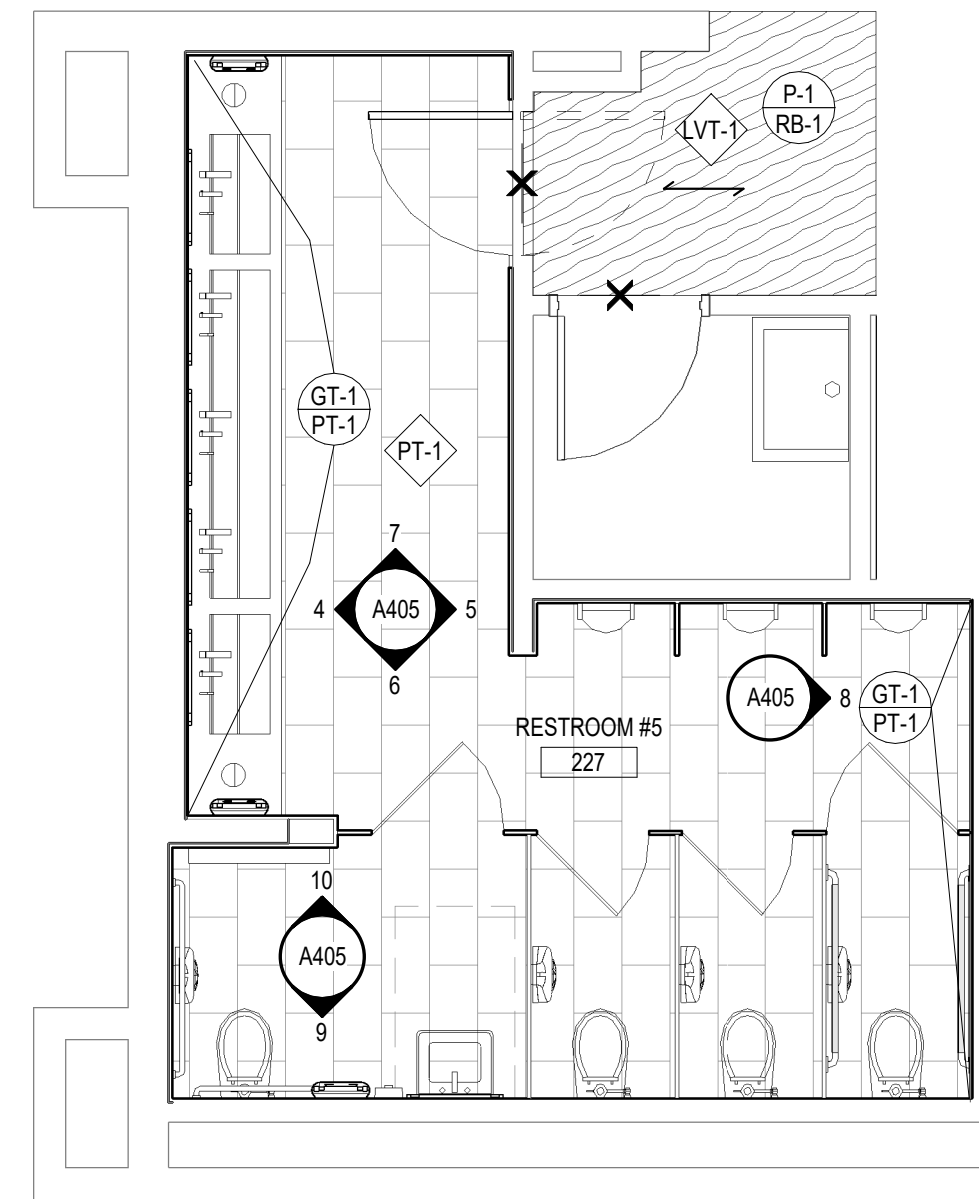

2 FINISH PLAN - RESTROOM 5
 SCALE: 1/4" = 1'-0"

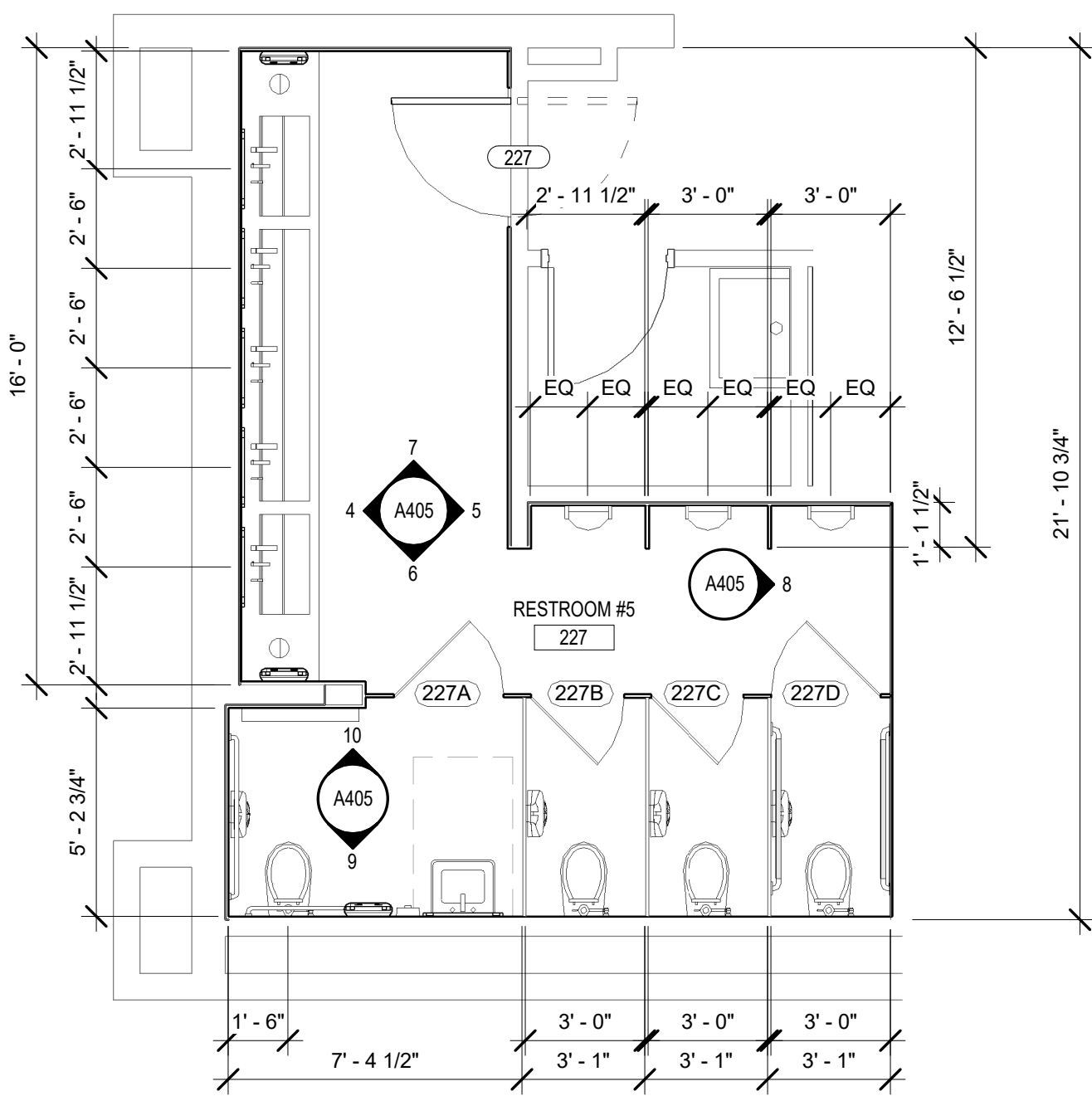

1 DIMENSION PLAN - RESTROOM 5
 SCALE: 1/4" = 1'-0"

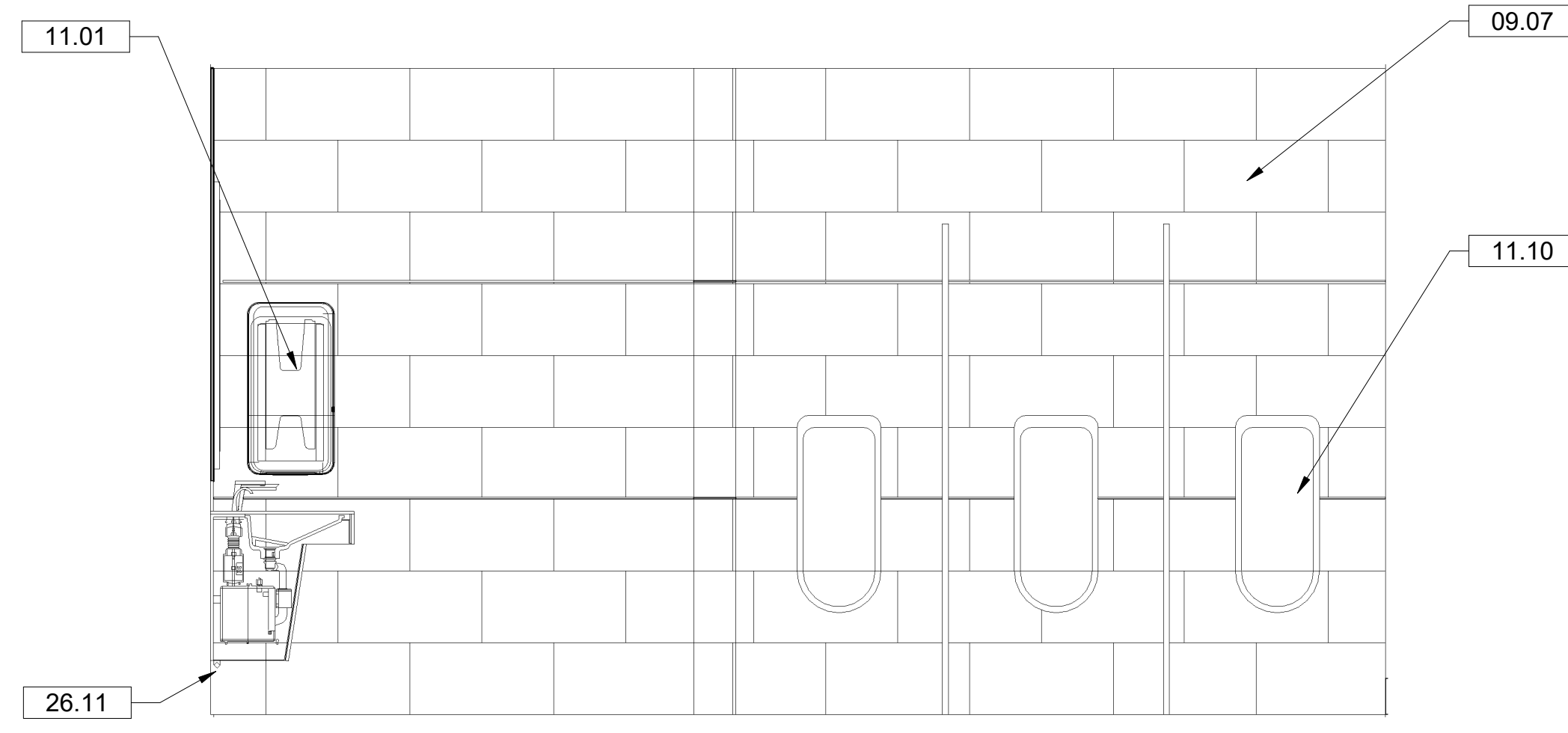

7 RESTROOM 5 - N. ELEV. a
 SCALE: 1/2" = 1'-0"

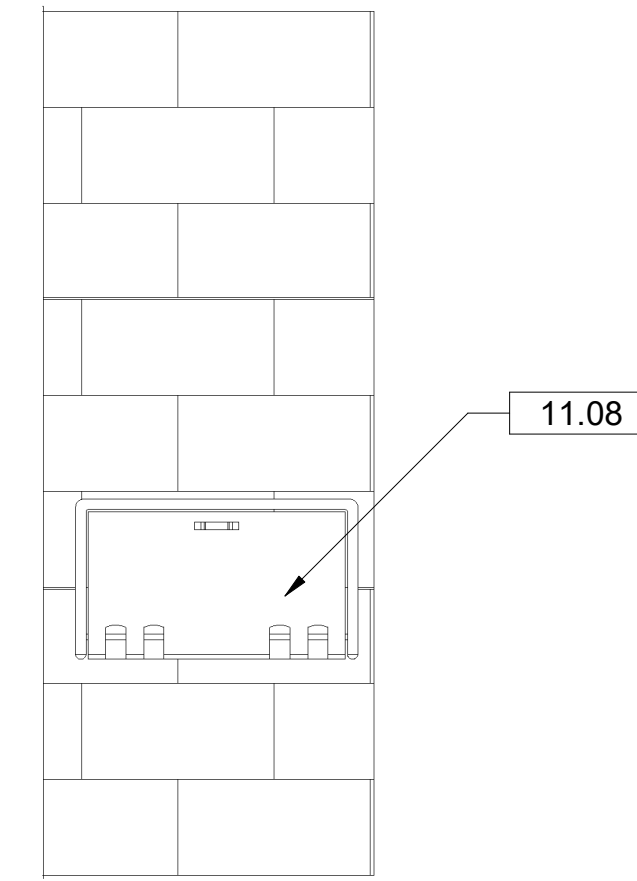

10 RESTROOM 5 - N. ELEV. b
 SCALE: 1/2" = 1'-0"

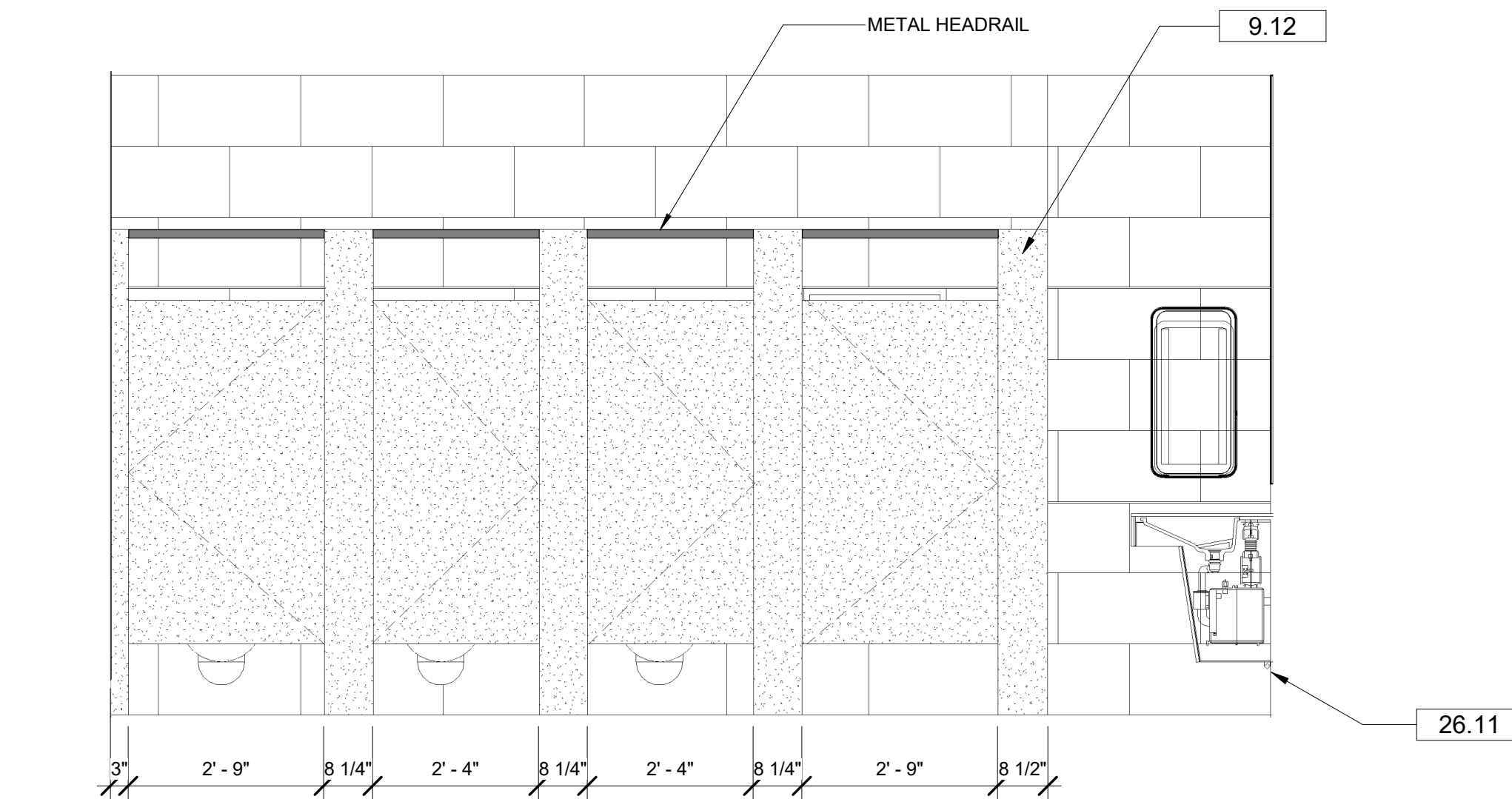

6 RESTROOM 5 - S. ELEV. a
 SCALE: 1/2" = 1'-0"

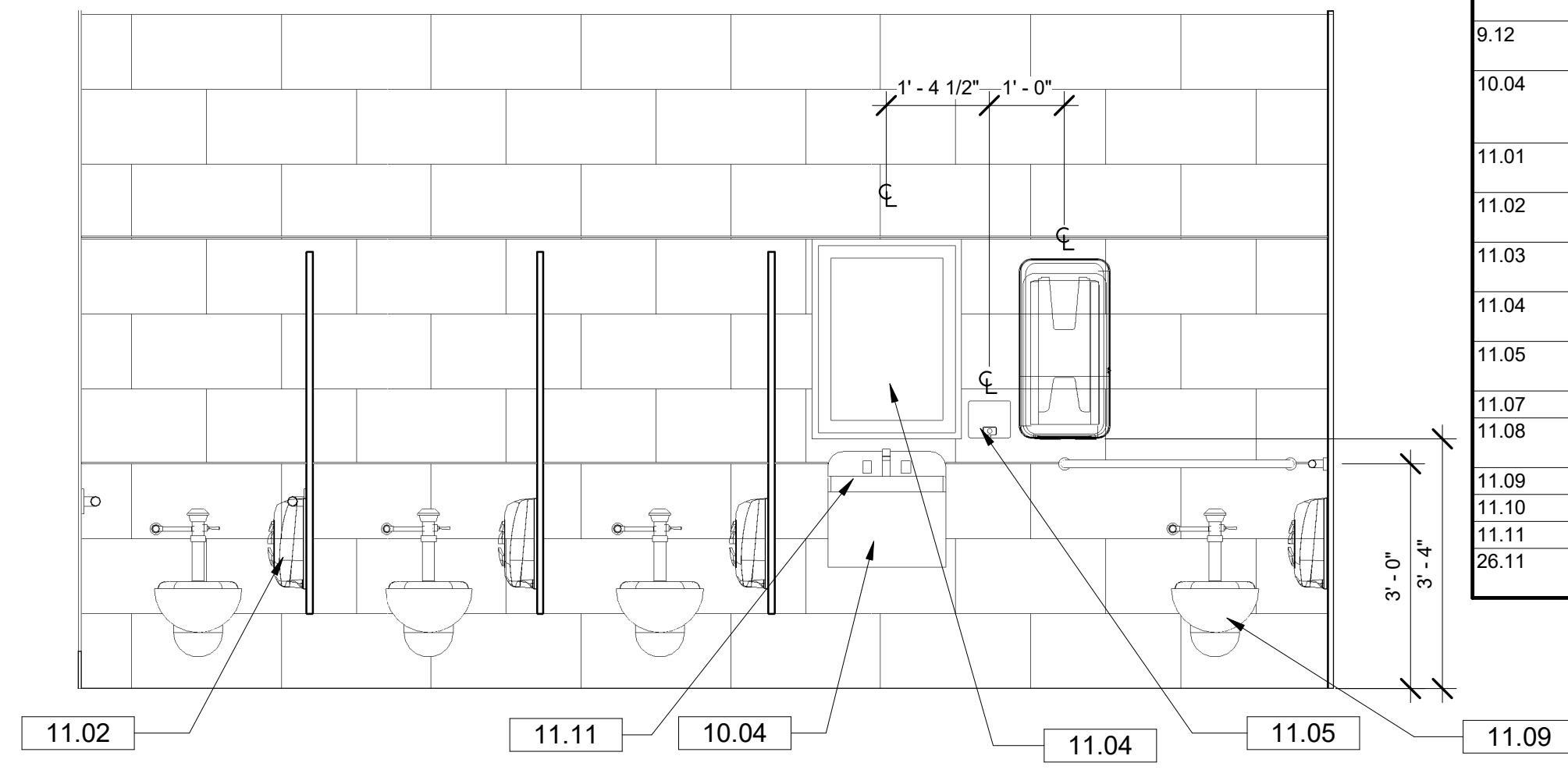

9 RESTROOM 5 - S. ELEV. b
 SCALE: 1/2" = 1'-0"

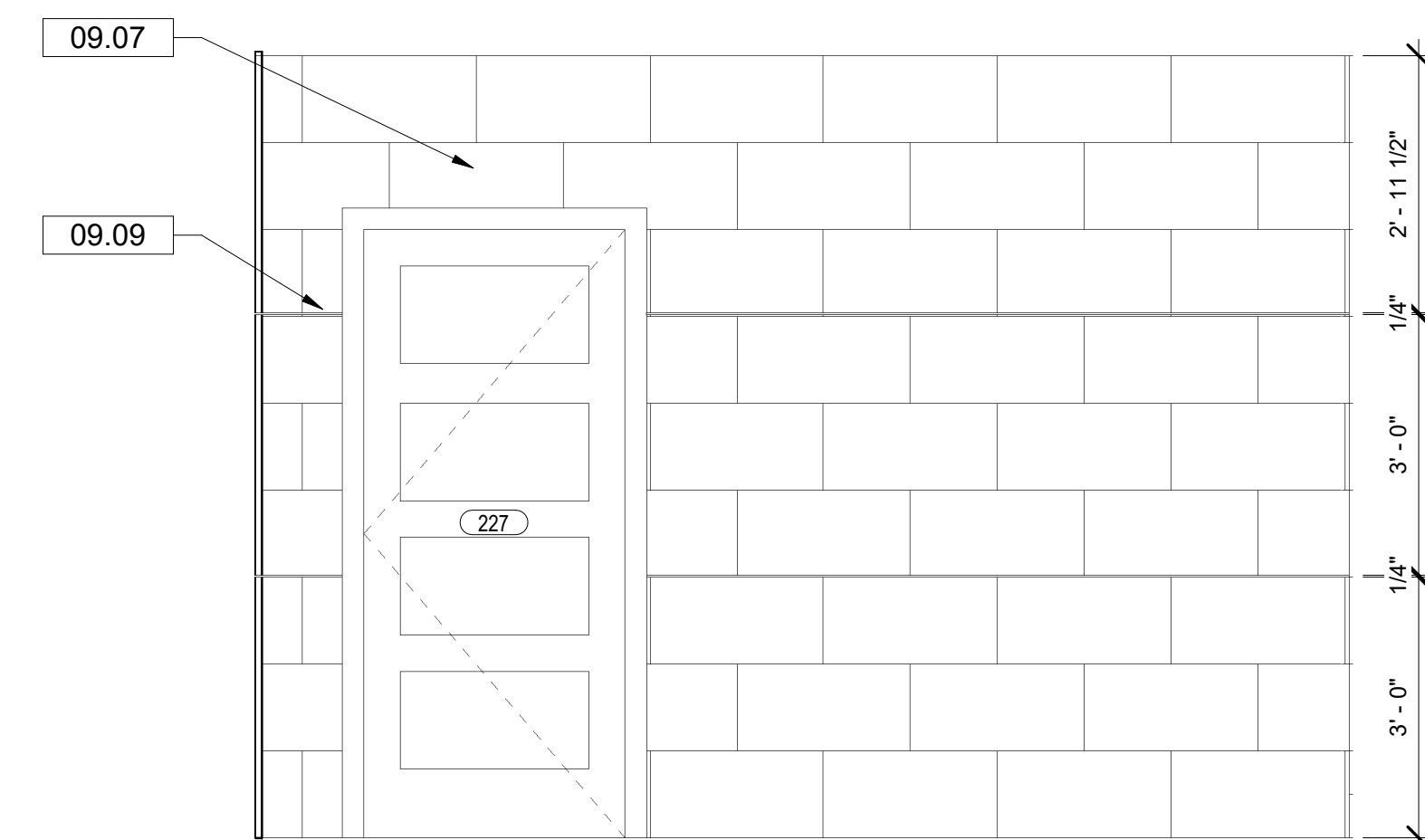

5 RESTROOM 5 - E. ELEV. a
 SCALE: 1/2" = 1'-0"

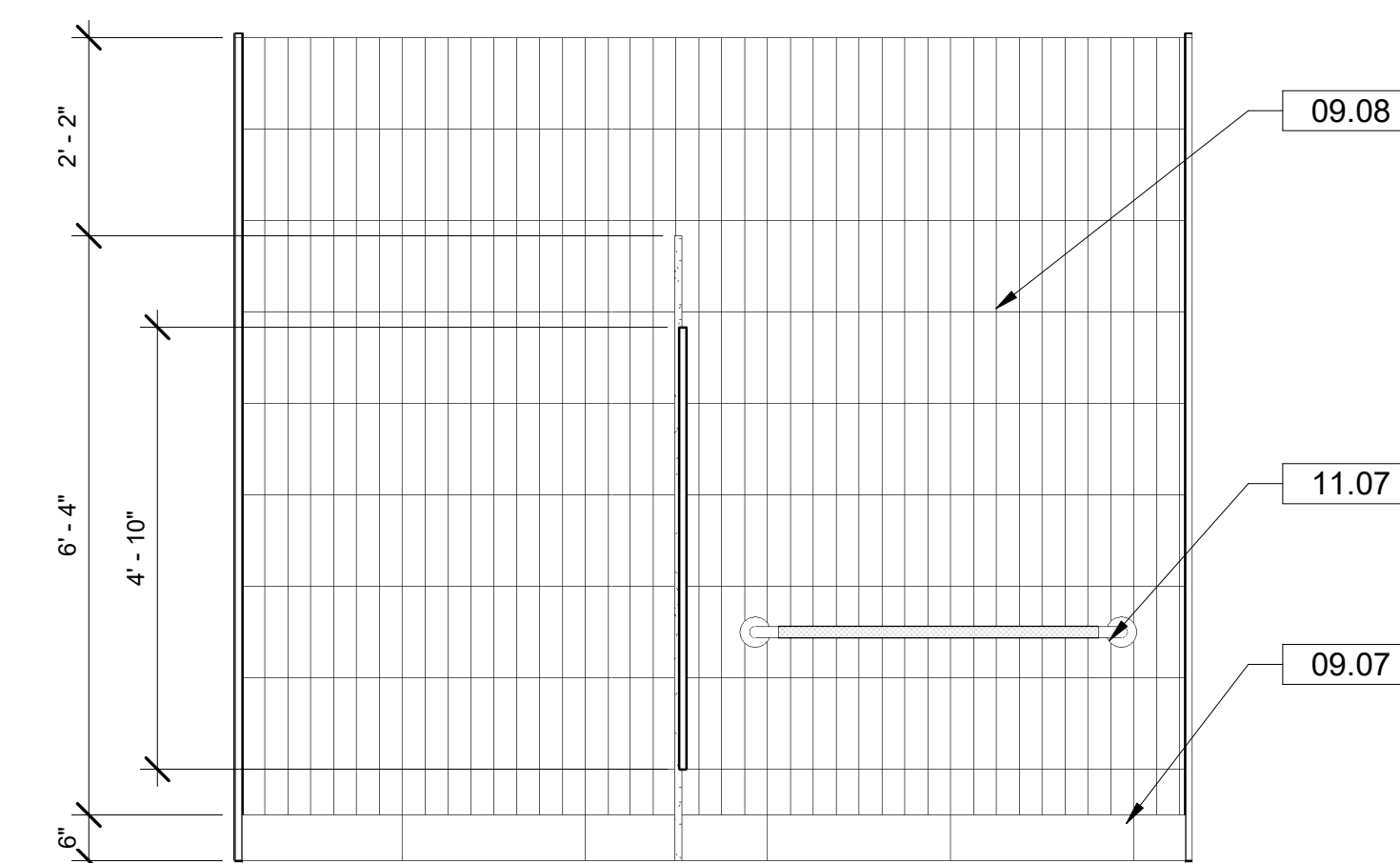

8 RESTROOM 5 - E. ELEV. b
 SCALE: 1/2" = 1'-0"

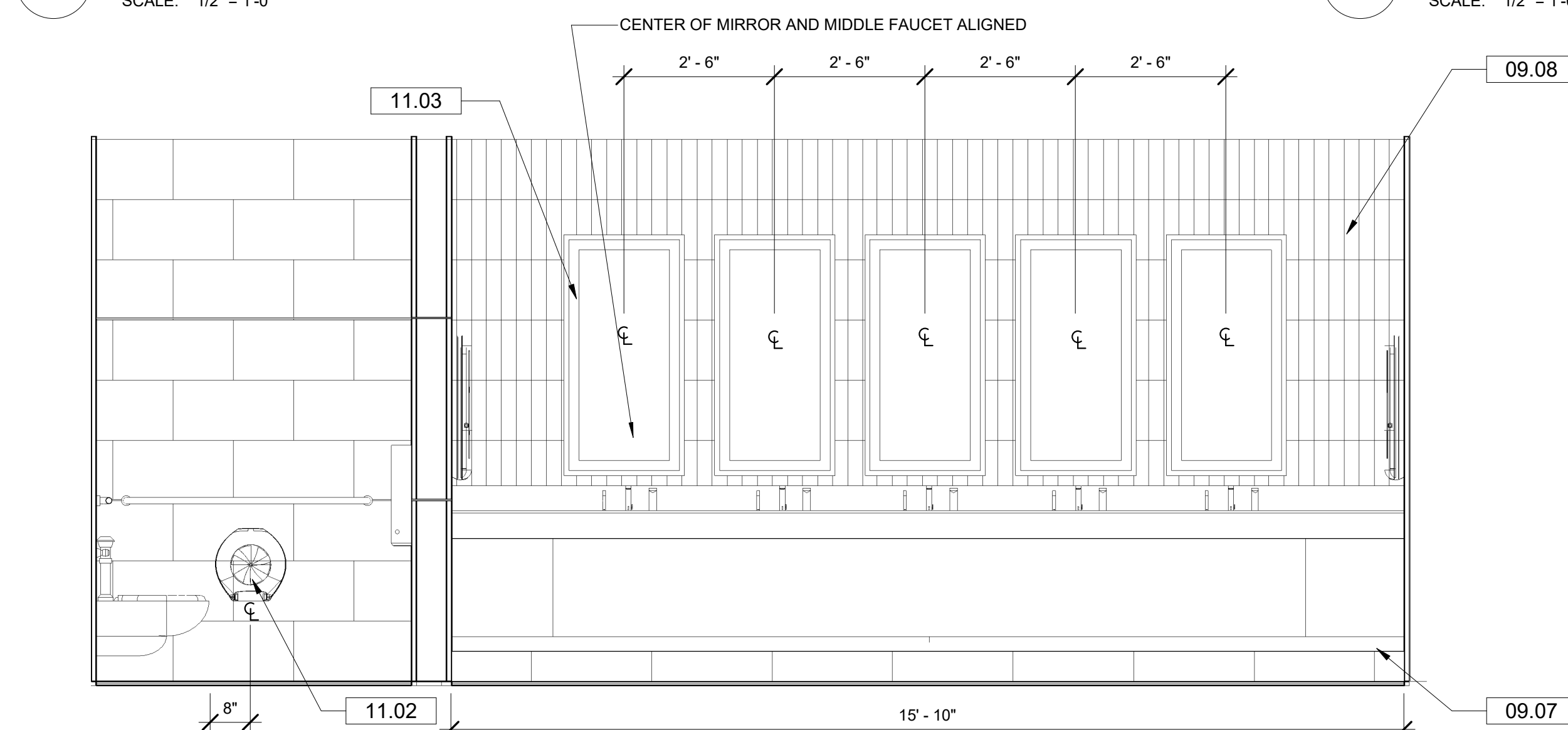

4 RESTROOM 5 - W. ELEV.
 SCALE: 1/2" = 1'-0"

GEN. NOTES: ENLG. PLAN

1. FIELD VERIFY ALL EXISTING CONDITIONS PRIOR TO PERFORMING NEW WORK.
2. THE CONTRACTOR SHALL PROVIDE REINFORCING BEHIND WALL MOUNTED AND CEILING MOUNTED EQUIPMENT.
3. CONTRACTOR SHALL COORDINATE WORK WITH MECHANICAL, ELECTRICAL AND PLUMBING DRAWINGS. REFER TO FINISH LEGEND ON SHEET A400 FOR MORE INFORMATION ABOUT FINISHES SHOWN ON THIS SHEET.
4. PROVIDE POSITIVE SLOPE TOWARDS ALL FLOOR DRAINS.
5. ALL BATHROOM STALLS ARE TO BE COMPOSITE STONE-PLY TOILET COMPARTMENT SYSTEM WITH EQT2-1 VENEER. INSTALL PER MANUFACTURER'S RECOMMENDATIONS.
6. STALL DOORS SHOWN IN ENLARGED FLOORPLANS AS A-H FOR PARTITION HARDWARE COORDINATION ONLY. NOT RELEVANT TO DOOR SCHEDULE.

GENERAL NOTES: RCP

1. SEE SHEET A400 FOR ROOM FINISH SCHEDULE FOR ADDITIONAL INFORMATION.
2. ALL ACCESS PANEL LOCATIONS TO BE COORDINATED WITH MECHANICAL, ELECTRICAL, PLUMBING AND FIRE SPRINKLER WORK.
3. REPLACE CEILING AT NEW HEIGHT IN RESTROOMS #1 TO #6. UPGRADING FIXTURES WHERE POSSIBLE.
4. SEE ELECTRICAL FOR LIGHTING FIXTURE SCHEDULE. WHERE APPLICABLE, ALL FIRE SPRINKLER HEADS AND ELECTRICAL FIXTURES SHALL BE CENTERED WITHIN CEILING TILES.
5. IF ANY ITEMS INDICATED ON THE DRAWINGS ARE IN CONFLICT WITH ONE ANOTHER, CONTRACTOR IS RESPONSIBLE FOR BRINGING TO ARCHITECT FOR FURTHER CLARIFICATION ON DESIGN INTENT.

KEYNOTES

NUMBER	DESCRIPTION
09.07	PT-1 PORCELAIN TILE: PORCELANOSA AVENUE GREY, 12X24, FINISH LAPPATO
09.08	GT-1 GLASS TILE: BODESI HAND PAINTED GLASS TILE, 4X12 CUSTOM COLOR
09.09	GT-2 GLASS PENCIL LINER: ELIDA CERAMICA 12X0.51, GLOSSY (OR SIMILAR)
9.12	EQT-1 ENGINEERED QUARTZ: SILESTONE, ETERNAL CALACATTA CLASSIC, POLISHED
10.04	RAKKS EHV-VANITY SUPPORT BRACKET SINK SURROUND (ADA INSTALLMENT AROUND SINK) CORIAN SOLID SURFACE PANELS
11.01	TORK HAND TOWEL DISPENSER, 552520, WHITE; OWNER PROVIDED, CONTRACTOR INSTALLED
11.02	TORK 3 ROLL BATH TISSUE ROLL DISPENSER, 555828, WHITE; OWNER PROVIDED, CONTRACTOR INSTALLED
11.03	MIRROR: PARIS MIRROR: LIGHTED MIRROR HARMONY: 24X48" LED 110V WIRING
11.04	MIRROR: PARIS MIRROR: LIGHTED MIRROR HARMONY: 24X32" LED 110V WIRING
11.05	SD SOAP DISPENSER; OWNER PROVIDED, CONTRACTOR INSTALLED
11.07	GS GRAB BAR (ADA HEIGHT) MOUNTED BETWEEN 33-36" AFF
11.08	CHANGING TABLE: KOALA KARE KB200-05, WHITE GRANITE; MOUNTED 24" AFF
11.09	ADA ADULT TOILET (WALL MOUNTED)
11.10	ADA ADULT URINAL (WALL MOUNTED)
11.11	ADA SINK SPECIFIED BY WATERFORD PLUMBING ENGINEER
26.11	LED LIGHTING UNDER SINK SYSTEM (ATTACHMENT NOT INCLUDED WITH SINK SYSTEM)



OWNERSHIP OF SERVICE
 ALL REPORTS, PLANS, SPECIFICATIONS, COMPUTER FILES, FIELD DATA, NOTES AND OTHER DOCUMENTS AND INSTRUMENTS PREPARED BY THE CONSULTANT AS AN INSTRUMENT OF SERVICE SHALL REMAIN THE PROPERTY OF THE CONSULTANT. THE CONSULTANT SHALL RETAIN ALL COMMON LAW, STATUTORY AND OTHER RESERVED RIGHTS, INCLUDING THE COPYRIGHT THERE TO.

PURSUANT TO FLORIDA STATUTES, SECTION 559.003, AN INDIVIDUAL EMPLOYEE OR AGENT MAY NOT BE HELD INDIVIDUALLY LIABLE FOR NEGLIGENCE.

BID DOCUMENTS

EMERALD COAST CONVENTION CENTER
RESTROOM RENOVATIONS & MEETING ROOM COUNTERS
 TASK ORDER NO. 5 - C-18-2638-TDD
 1250 MIRACLE STRIP PKWY SE
 FORT WALTON BEACH, FL 32548

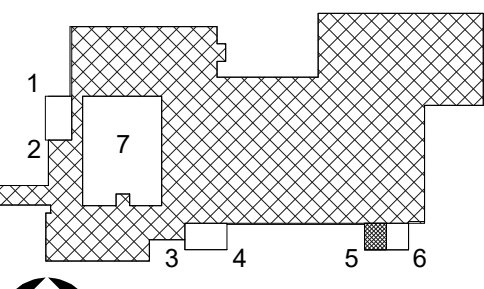

REVISIONS:

No.	Description	Date

ENLARGED PLAN - RESTROOM 5

Project number	17057.5
Dated	JANUARY 2019
PIC	Approver
PM	Designer

A405
 Scale As indicated

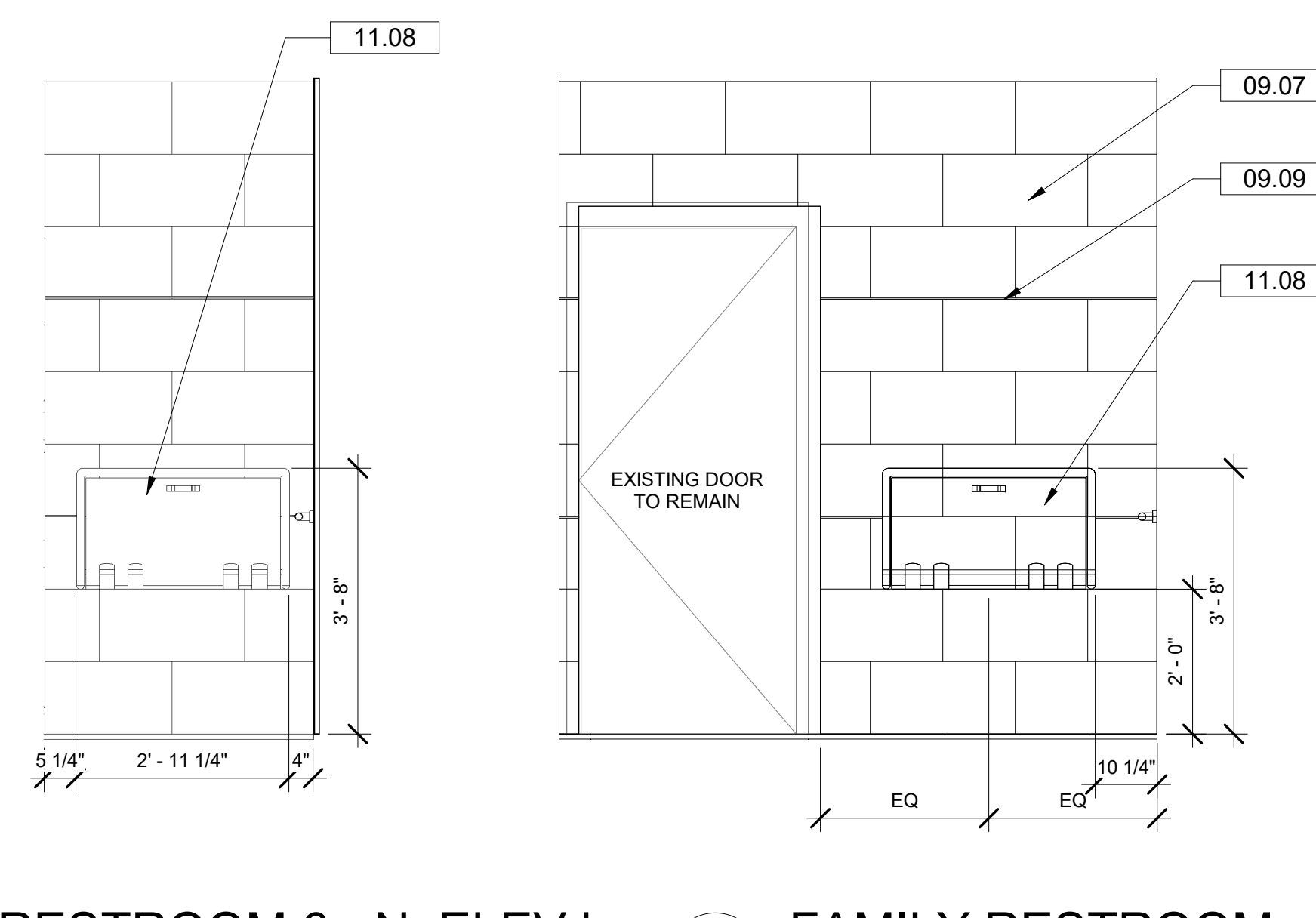
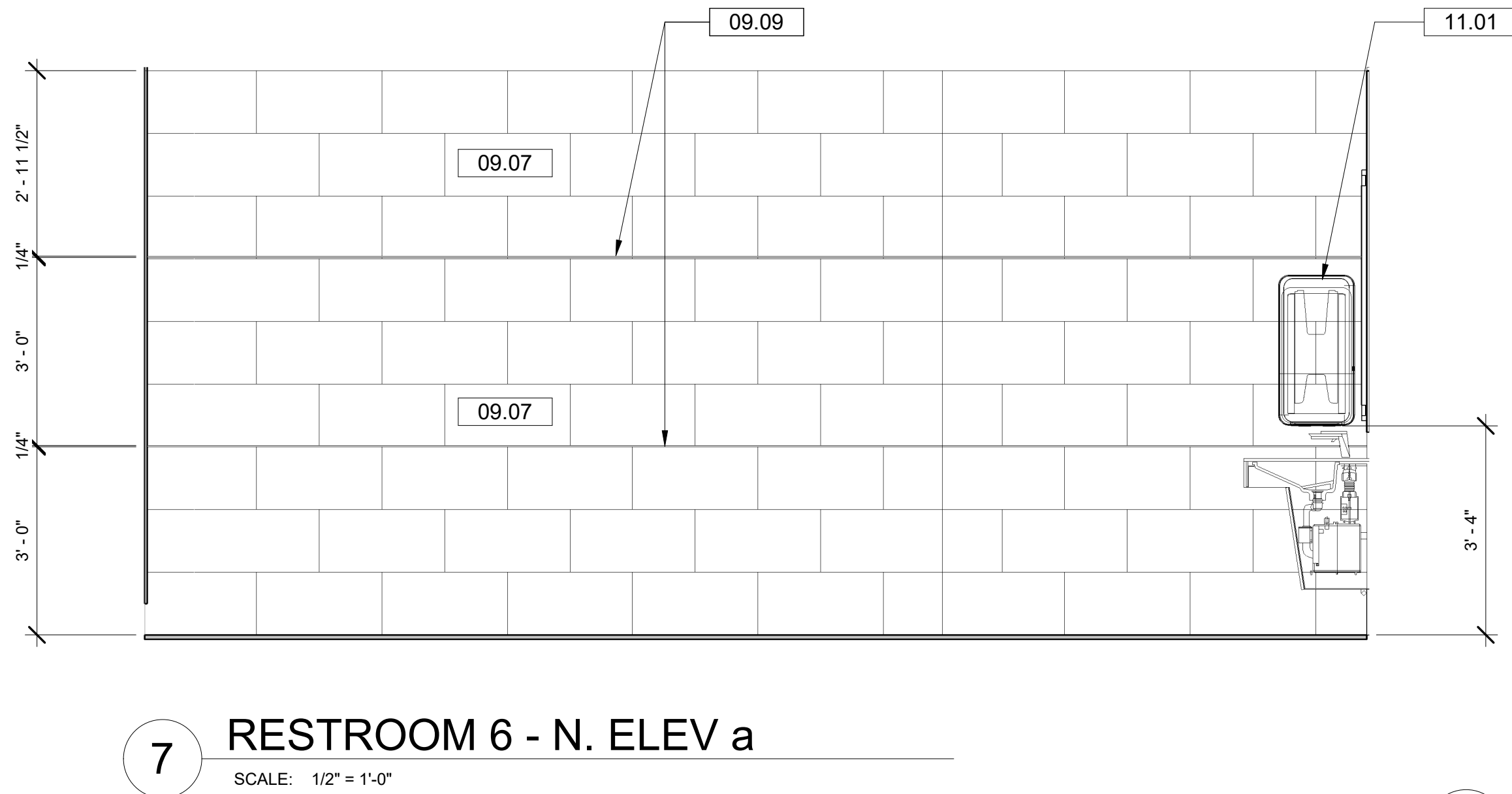
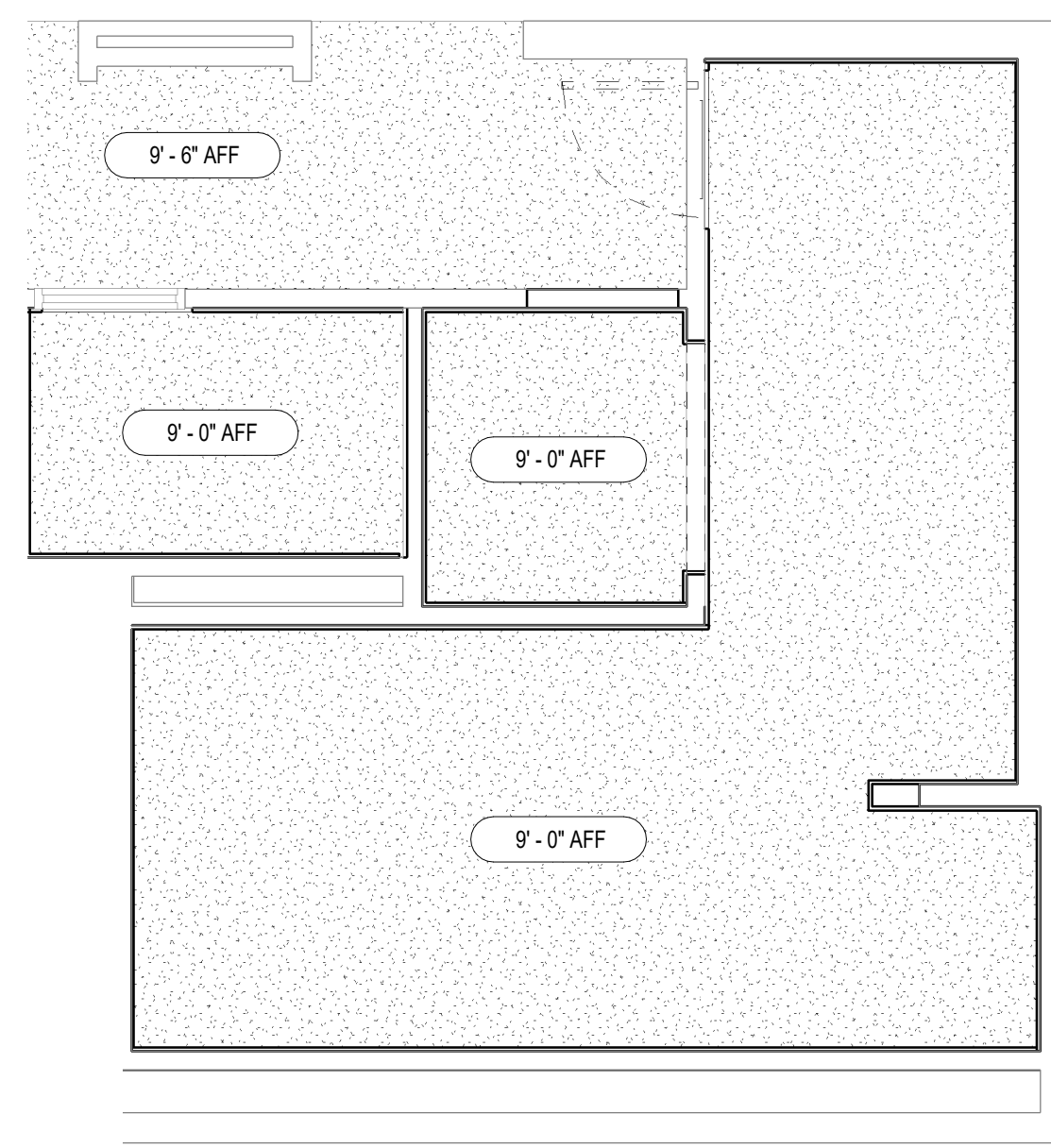

GEN. NOTES: ENLG. PLAN

1. FIELD VERIFY ALL EXISTING CONDITIONS PRIOR TO PERFORMING NEW WORK.
2. THE CONTRACTOR SHALL PROVIDE REINFORCING BEHIND WALL MOUNTED AND CEILING MOUNTED EQUIPMENT.
3. CONTRACTOR SHALL COORDINATE WORK WITH MECHANICAL, ELECTRICAL AND PLUMBING DRAWINGS.
4. REFER TO FINISH LEGEND ON SHEET A400 FOR MORE INFORMATION ABOUT FINISHES SHOWN ON THIS SHEET.
5. PROVIDE POSITIVE SLOPE TOWARDS ALL FLOOR DRAINS.
6. ALL BATHROOM STALLS ARE TO BE COMPOSITE STONE-FLY TOILET COMPARTMENT SYSTEM WITH EQTZ-1 VENEER. INSTALL PER MANUFACTURER'S RECOMMENDATIONS.
7. STALL DOORS SHOWN IN ENLARGED FLOORPLANS AS A-H FOR PARTITION HARDWARE COORDINATION ONLY. NOT RELEVANT TO DOOR SCHEDULE.

GENERAL NOTES: RCP

1. SEE SHEET A400 FOR ROOM FINISH SCHEDULE FOR ADDITIONAL INFORMATION.
2. ALL ACCESS PANEL LOCATIONS TO BE COORDINATED WITH MECHANICAL, ELECTRICAL, PLUMBING AND FIRE SPRINKLER WORK.
3. REPLACE CEILING AT NEW HEIGHT IN RESTROOMS #1 TO #6. UPGRADING FIXTURES WHERE POSSIBLE.
4. SEE ELECTRICAL FOR LIGHTING FIXTURE SCHEDULE. WHERE APPLICABLE, ALL FIRE SPRINKLER HEADS AND ELECTRICAL FIXTURES SHALL BE CENTERED WITHIN CEILING TILES.
5. IF ANY ITEMS INDICATED ON THE DRAWINGS ARE IN CONFLICT WITH ONE ANOTHER, CONTRACTOR IS RESPONSIBLE FOR BRINGING TO ARCHITECT FOR FURTHER CLARIFICATION ON DESIGN INTENT.



OWNERSHIP OF SERVICE
 ALL REPORTS, PLANS, SPECIFICATIONS, COMPUTER FILES, FIELD DATA, NOTES AND OTHER DOCUMENTS AND INSTRUMENTS PREPARED BY THE CONSULTANT AS AN INSTRUMENT OF SERVICES SHALL REMAIN THE PROPERTY OF THE CONSULTANT. THE CONSULTANT SHALL RETAIN ALL COMMON LAW, STATUTORY AND OTHER RESERVED RIGHTS, INCLUDING THE COPYRIGHT THERE TO.

PURSUANT TO FLORIDA STATUTES, SECTION 550.003, AN INDIVIDUAL EMPLOYEE OR AGENT MAY NOT BE HELD INDIVIDUALLY LIABLE FOR NEGLIGENCE.

BID DOCUMENTS

EMERALD COAST CONVENTION CENTER
RESTROOM RENOVATIONS & MEETING ROOM COUNTERS
 TASK ORDER NO. 5 - C-18-2638-TDD
 1250 MIRACLE STRIP PKWY SE
 FORT WALTON BEACH, FL 32548

KEYNOTES

NUMBER	DESCRIPTION
09.07	PT-1 PORCELAIN TILE: PORCELANOSA AVENUE GREY, 12X24, FINISH LAPPATO
09.08	GT-1 GLASS TILE: BODESI HAND PAINTED GLASS TILE, 4X12 CUSTOM COLOR
09.09	GT-2 GLASS PENCIL LINER: ELIDA CERAMICA 12X0.51, GLOSSY (OR SIMILAR)
9.12	EQTZ-1 ENGINEERED QUARTZ: SILESTONE, ETERNAL CALACATTA CLASSIC, POLISHED
10.04	RAKKS EHV-VANITY SUPPORT BRACKET SINK SURROUND (ADA INSTALLMENT AROUND SINK) CORIAN SOLID SURFACE PANELS
11.01	TORK HAND TOWEL DISPENSER, 552520, WHITE; OWNER PROVIDED, CONTRACTOR INSTALLED
11.02	TORK 3 ROLL BATH TISSUE ROLL DISPENSER, 568828; WHITE; OWNER PROVIDED, CONTRACTOR INSTALLED
11.03	MIRROR: PARIS MIRROR: LIGHTED MIRROR HARMONY; 24X48" LED 110V WIRING
11.04	MIRROR: PARIS MIRROR: LIGHTED MIRROR HARMONY; 24X32" LED 110V WIRING
11.05	SD: SOAP DISPENSER; OWNER PROVIDED, CONTRACTOR INSTALLED
11.06	WATER COOLER SPECIFIED BY WATFORD PLUMBING ENGINEER
11.07	GB: GRAB BAR (ADA HEIGHT) MOUNTED BETWEEN 33-36" AFF
11.08	CHANGING TABLE: KOALA KARE KB200-05, WHITE GRANITE; MOUNTED 24" AFF
11.09	ADA ADULT TOILET (WALL MOUNTED)
11.11	ADA SINK SPECIFIED BY WATFORD PLUMBING ENGINEER
26.11	LED LIGHTING UNDER SINK SYSTEM (ATTACHMENT NOT INCLUDED WITH SINK SYSTEM)

3 LVL 01 RCP - RESTROOM 6
 SCALE: 1/4" = 1'-0"

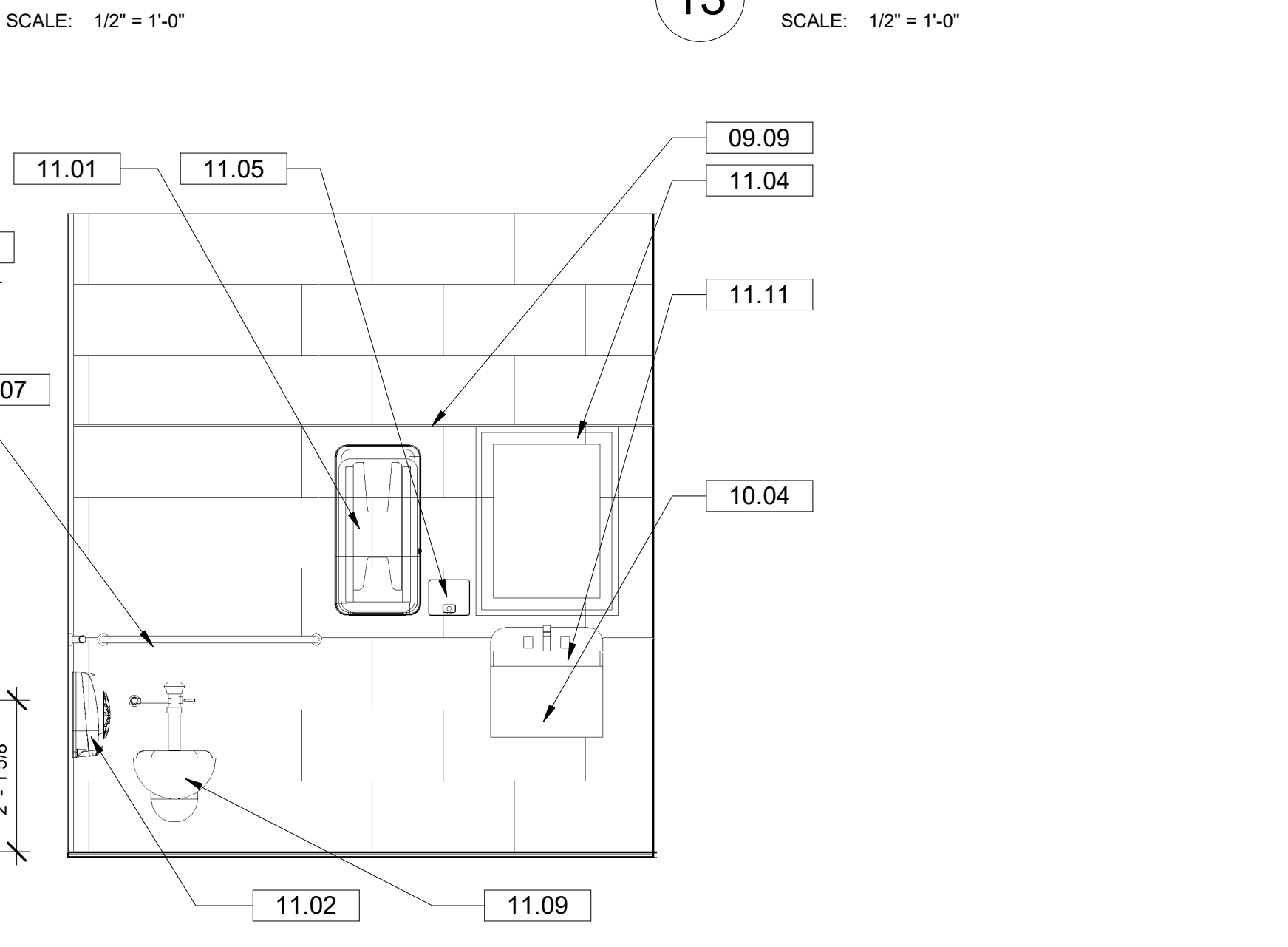
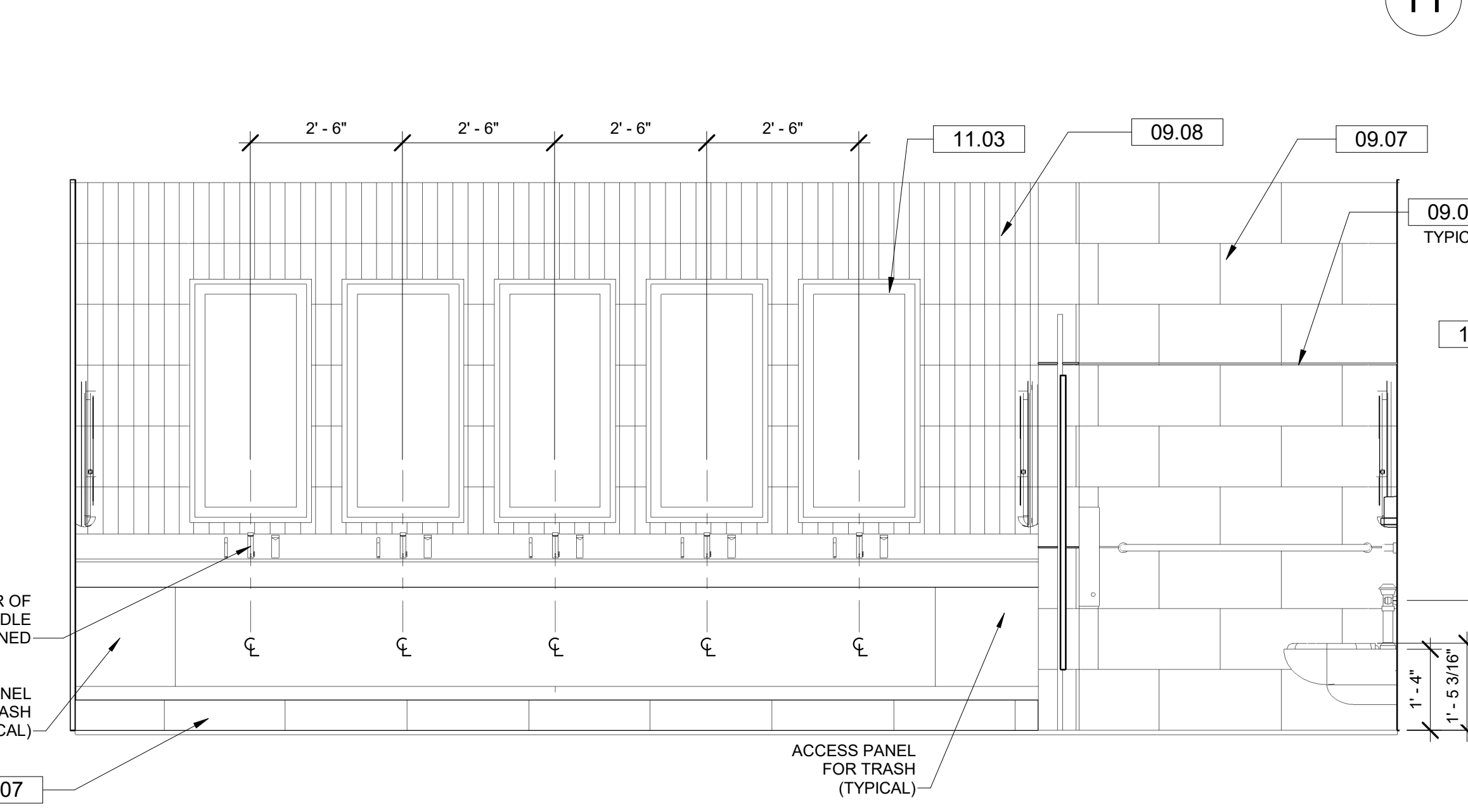
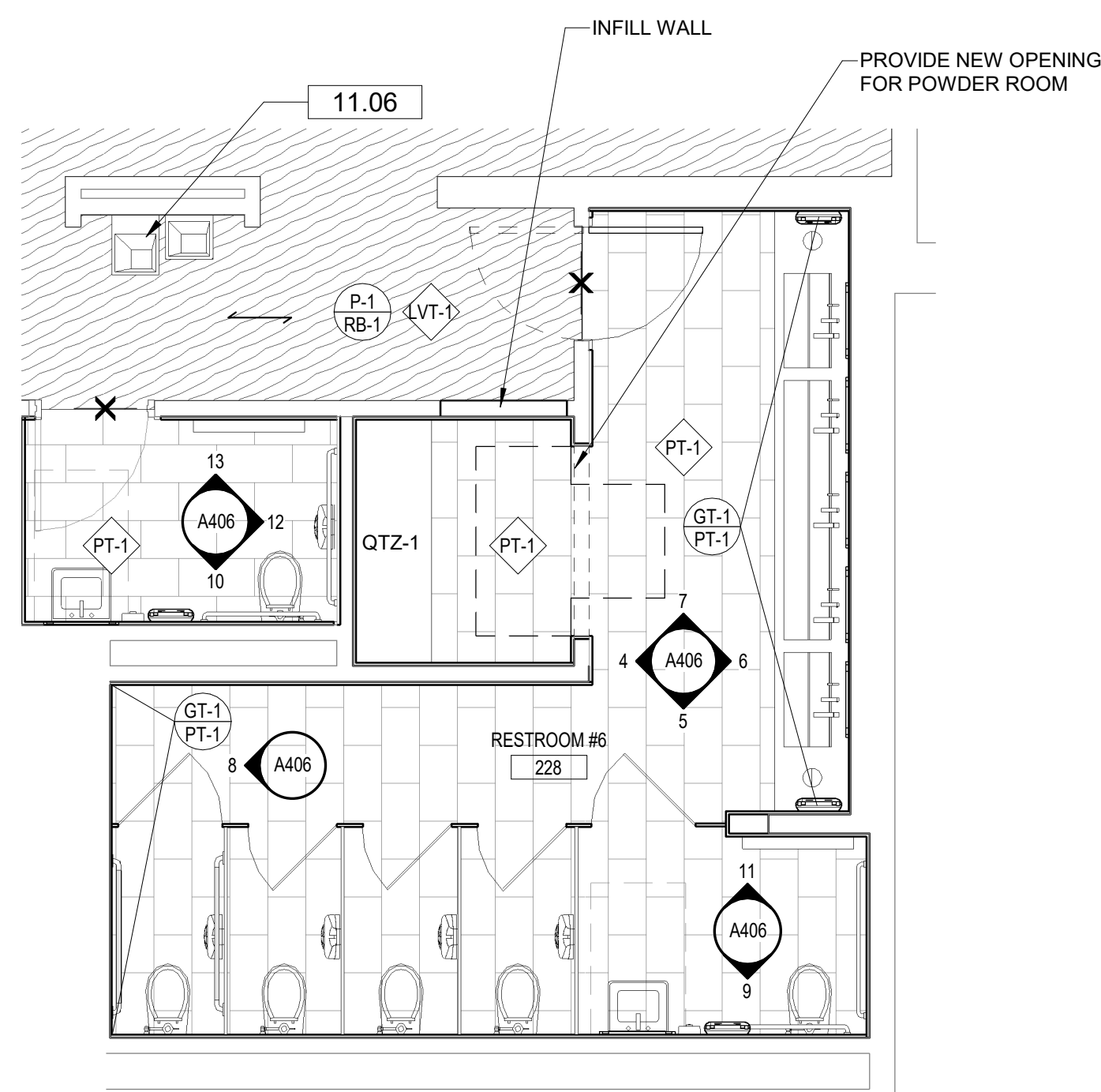

6 RESTROOM 6 - E. ELEV
 SCALE: 1/2" = 1'-0"

10 FAMILY RESTROOM # - S. ELEV.
 SCALE: 1/2" = 1'-0"

2 FINISH PLAN - RESTROOM 6
 SCALE: 1/4" = 1'-0"

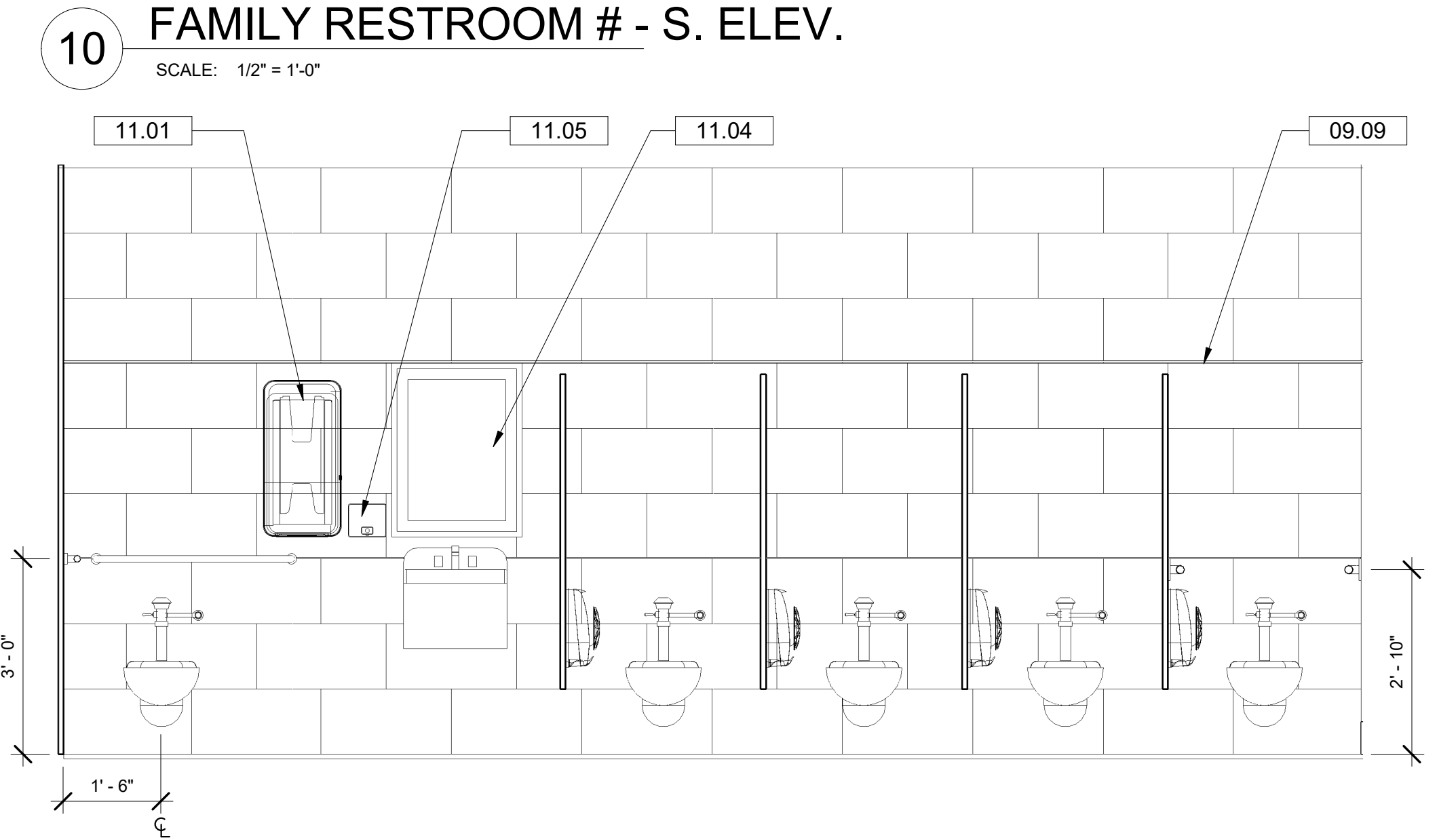
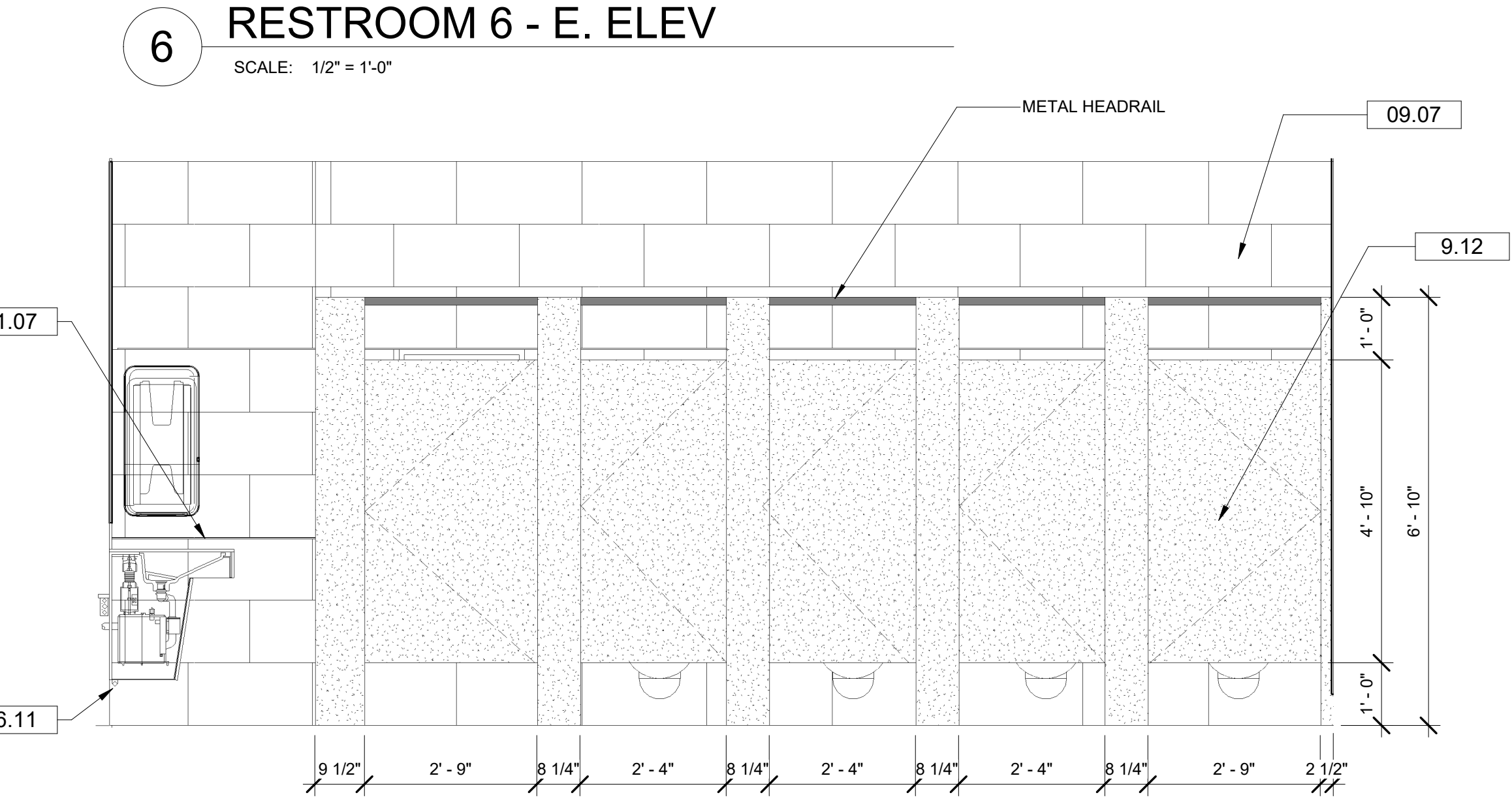
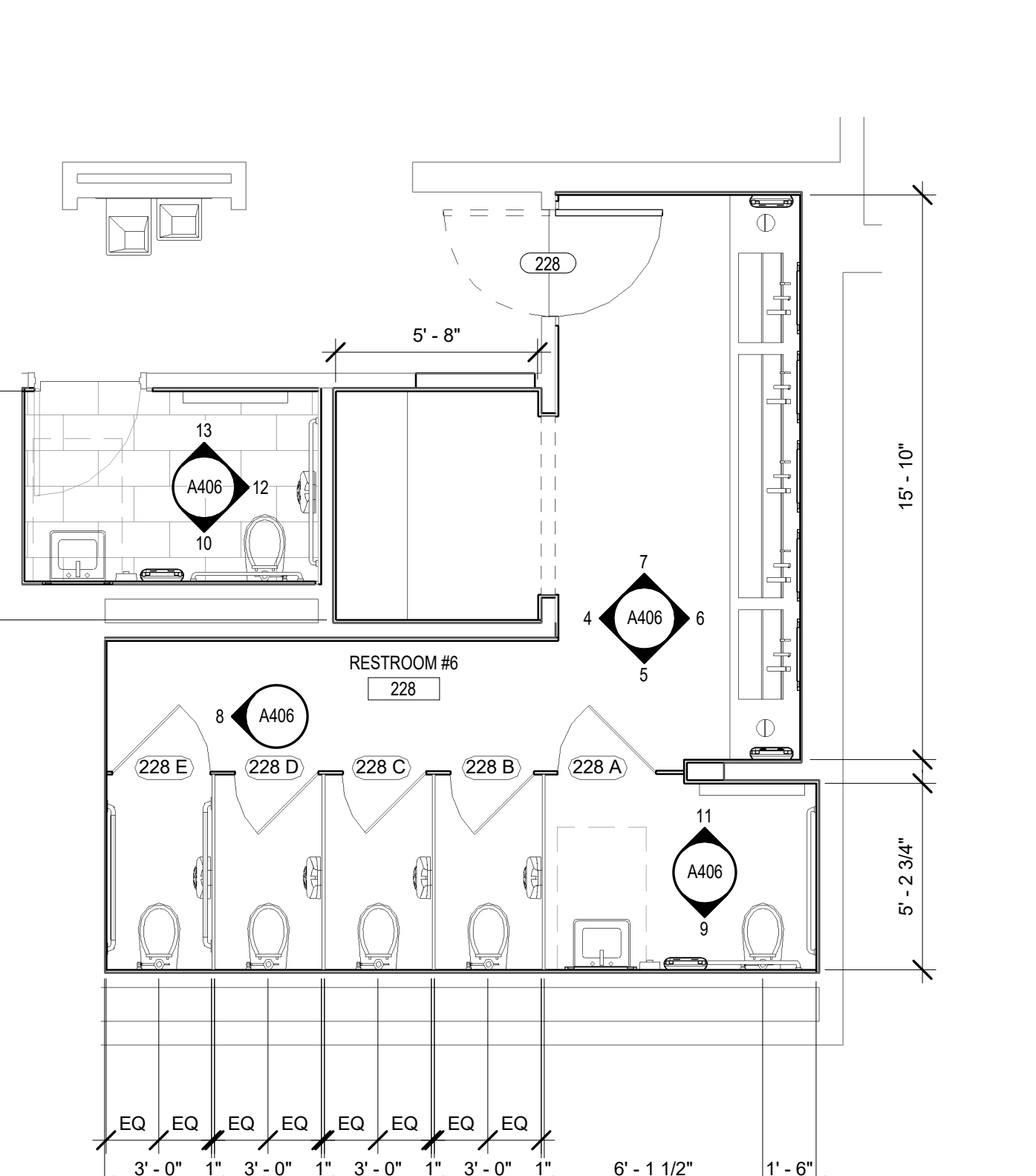

5 RESTROOM 6 - S. ELEV a
 SCALE: 1/2" = 1'-0"

9 RESTROOM 6 - S. ELEV. b
 SCALE: 1/2" = 1'-0"

1 DIMENSION PLAN - RESTROOM 6
 SCALE: 1/4" = 1'-0"

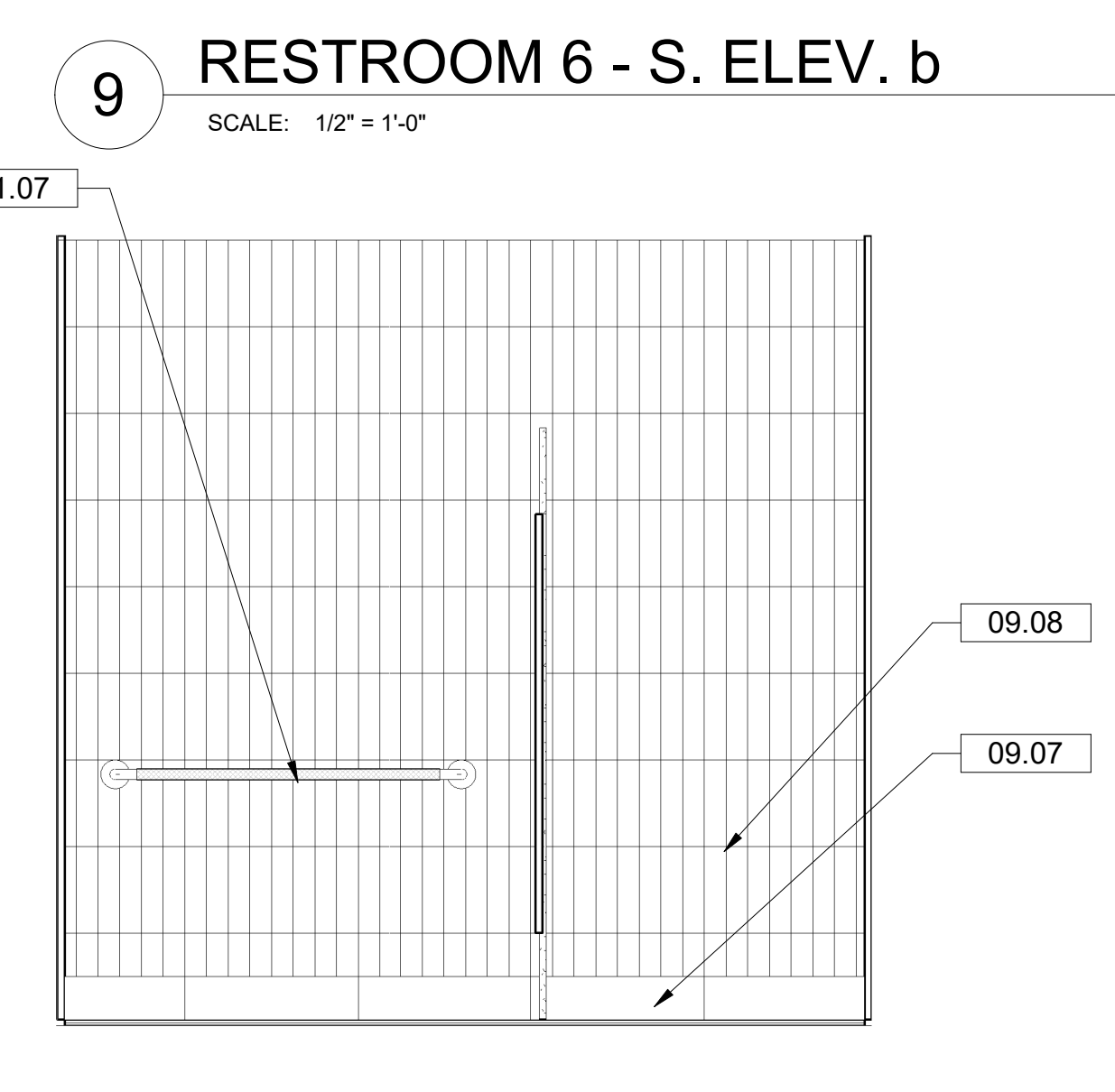
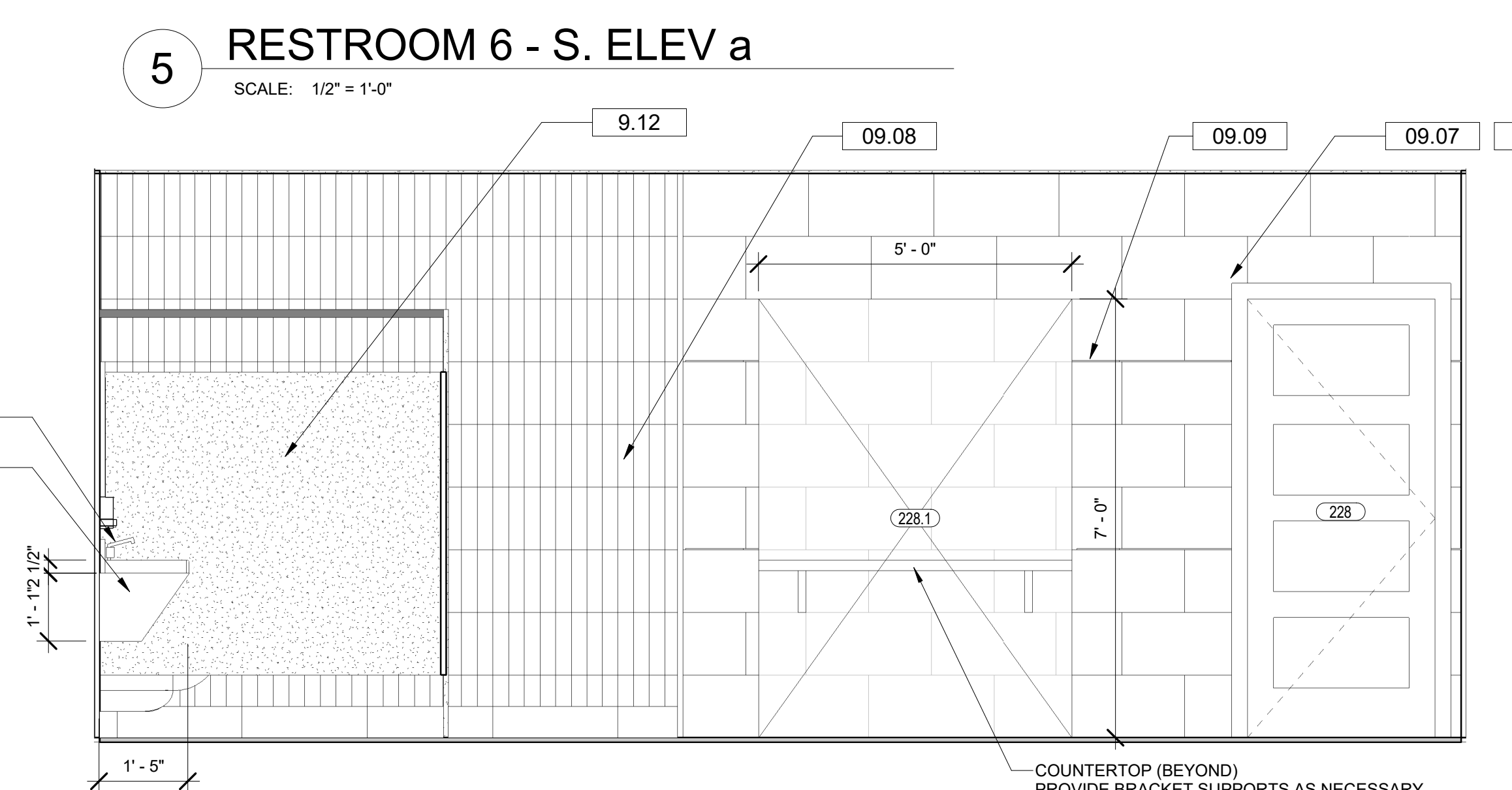

4 RESTROOM 6 - W. ELEV a
 SCALE: 1/2" = 1'-0"

8 RESTROOM 6 - W. ELEV b
 SCALE: 1/2" = 1'-0"

12 FAMILY RESTROOM # - E. ELEV.
 SCALE: 1/2" = 1'-0"

REVISIONS:

No.	Description	Date

ENLARGED PLAN - RESTROOM 6

Project number	17057.5
Dated	JANUARY 2019
PIC	Approver
PM	Designer

A406
 Scale As indicated



OWNERSHIP OF SERVICE
 ALL REPORTS, PLANS, SPECIFICATIONS, COMPUTER FILES,
 FIELD DATA, NOTES AND OTHER DOCUMENTS AND
 INSTRUMENTS PREPARED BY THE CONSULTANT AS AN
 INSTRUMENT OF SERVICE SHALL REMAIN THE PROPERTY OF
 THE CONSULTANT. THE CONSULTANT SHALL RETAIN ALL
 COMMON LAW, STATUTORY AND OTHER RESERVED RIGHTS,
 INCLUDING THE COPYRIGHT THERE TO.

PURSUANT TO FLORIDA STATUTES, SECTION 550.003, AN
 INDIVIDUAL EMPLOYEE OR AGENT MAY NOT BE HELD
 INDIVIDUALLY LIABLE FOR NEGLIGENCE.

BID DOCUMENTS

EMERALD COAST CONVENTION CENTER
**RESTROOM RENOVATIONS & MEETING ROOM
 COUNTERS**
 TASK ORDER NO. 5 - C-18-2638-TDD
 1250 MIRACLE STRIP PKWY SE
 FORT WALTON BEACH, FL 32548

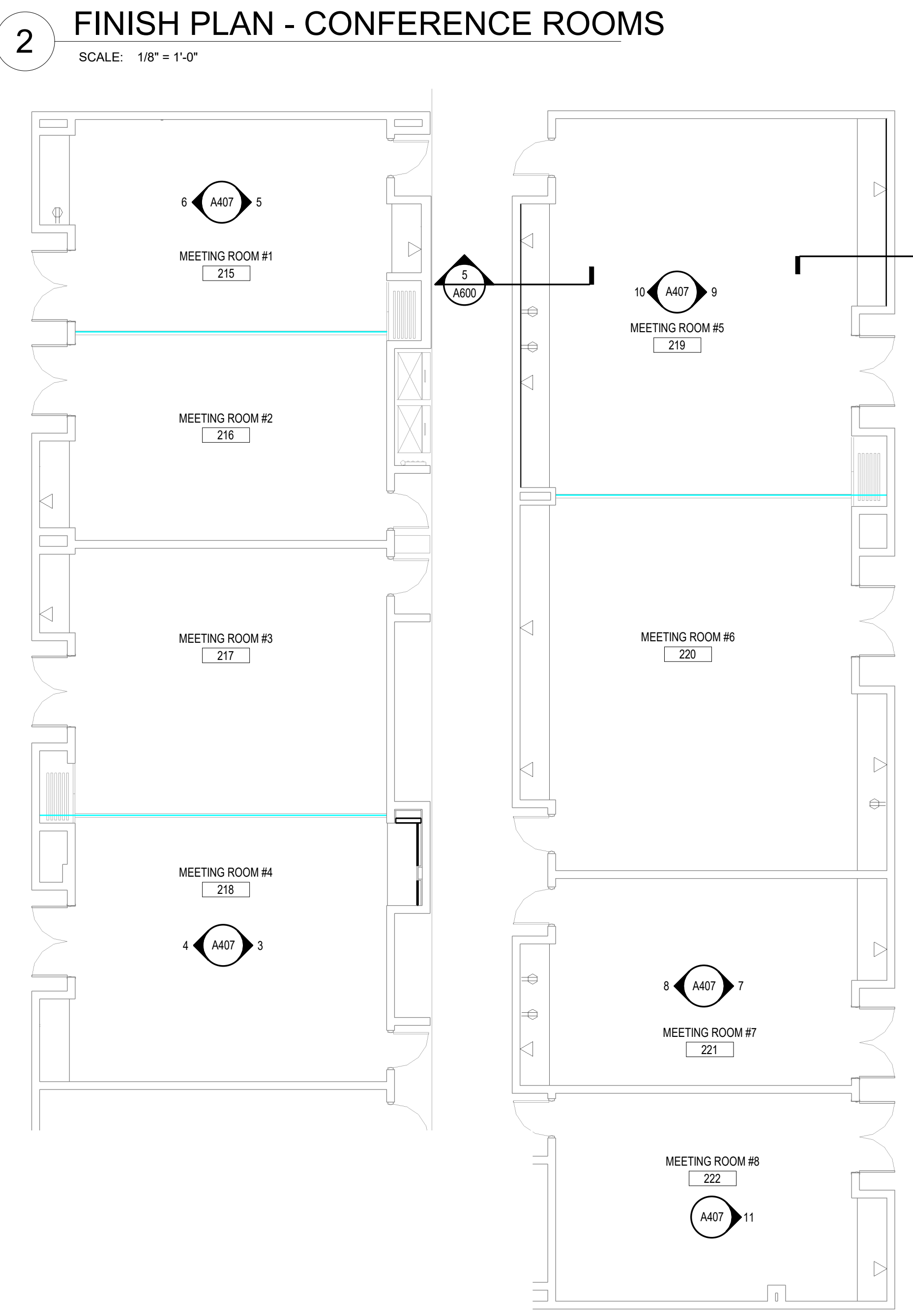
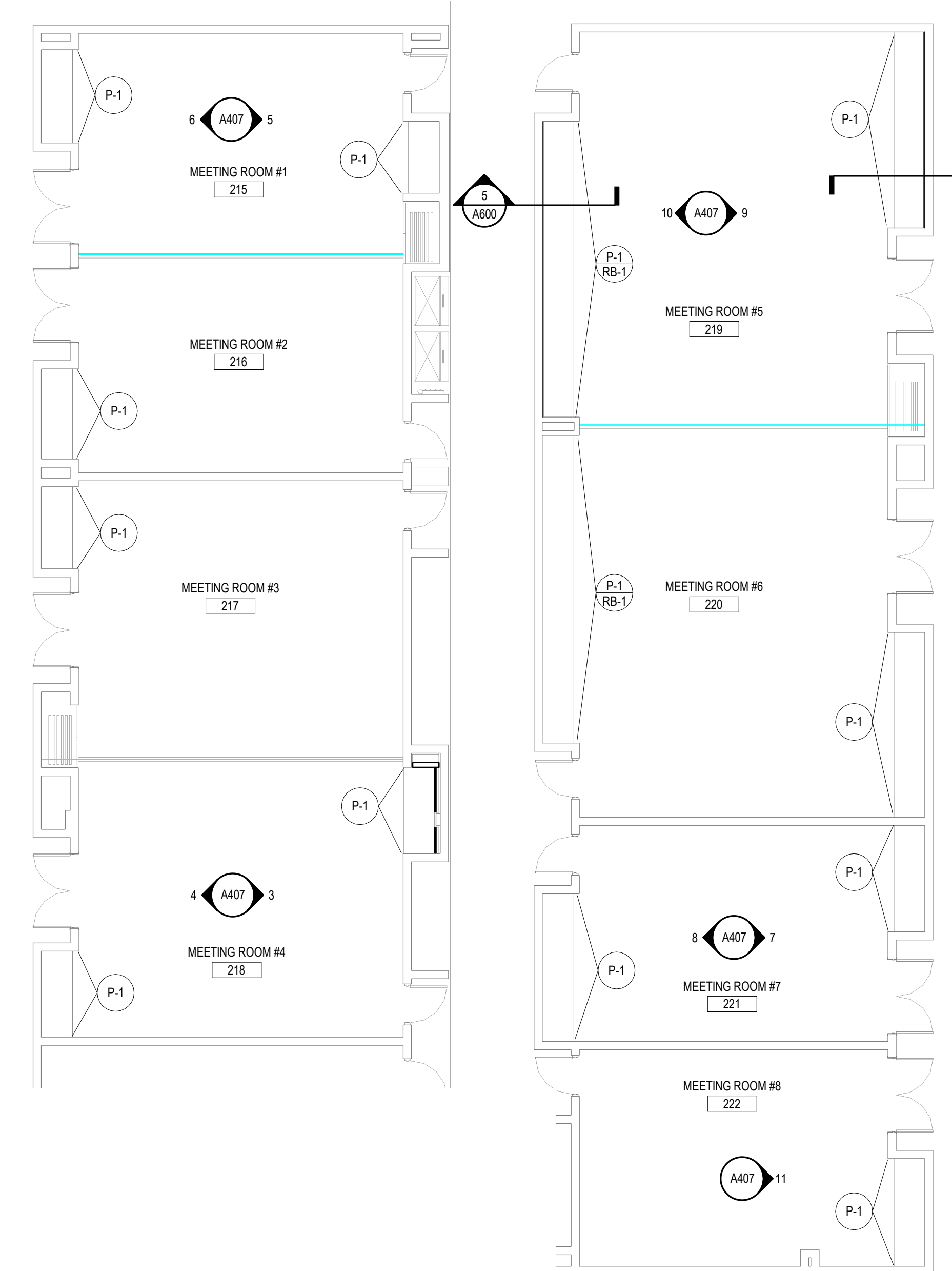

1 ENLARGED PLAN - CONFERENCE ROOMS
 SCALE: 1/8" = 1'-0"

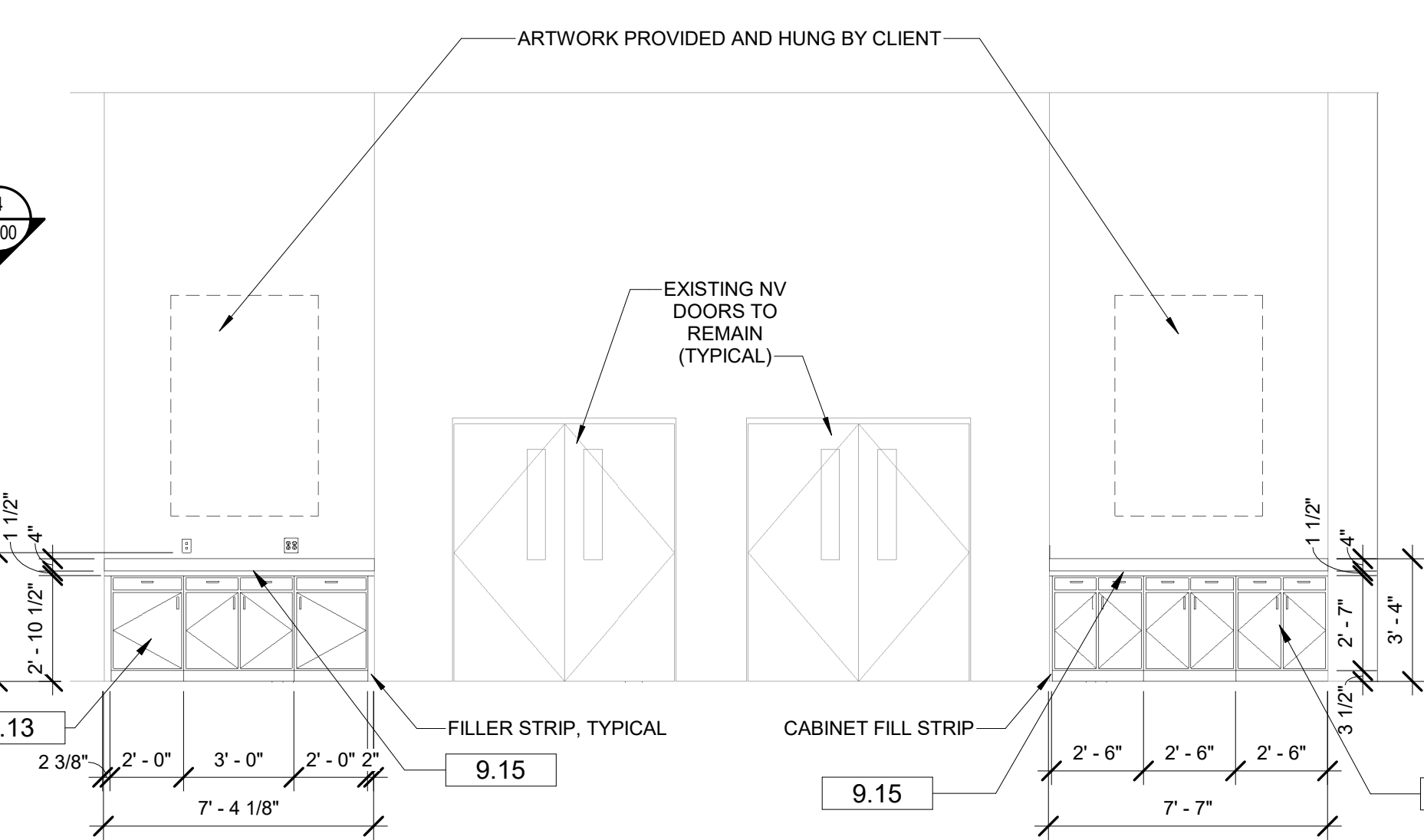

6 W. MEETING RM 1 & 2
 SCALE: 1/4" = 1'-0"

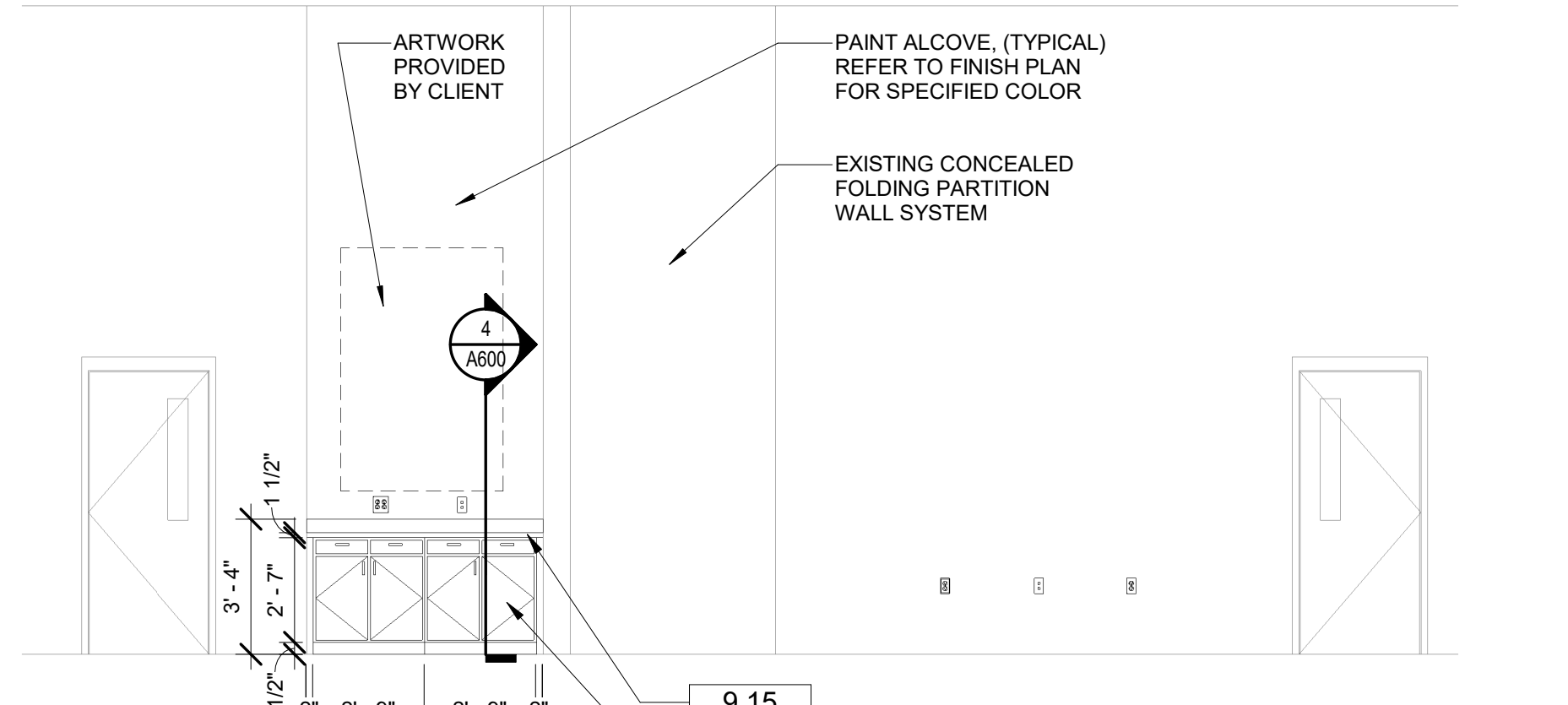

5 E. MEETING RM 1 & 2
 SCALE: 1/4" = 1'-0"

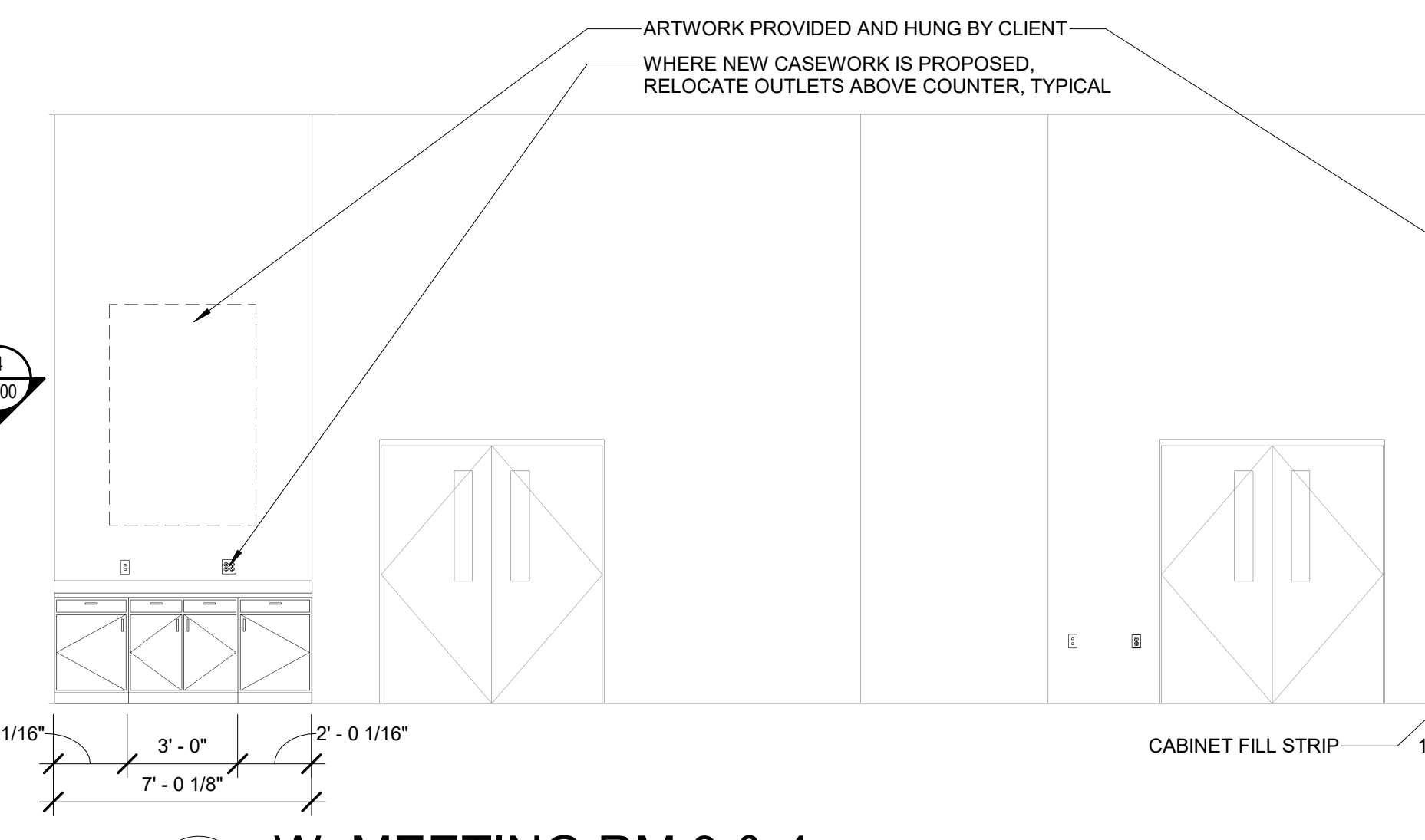

4 W. MEETING RM 3 & 4
 SCALE: 1/4" = 1'-0"

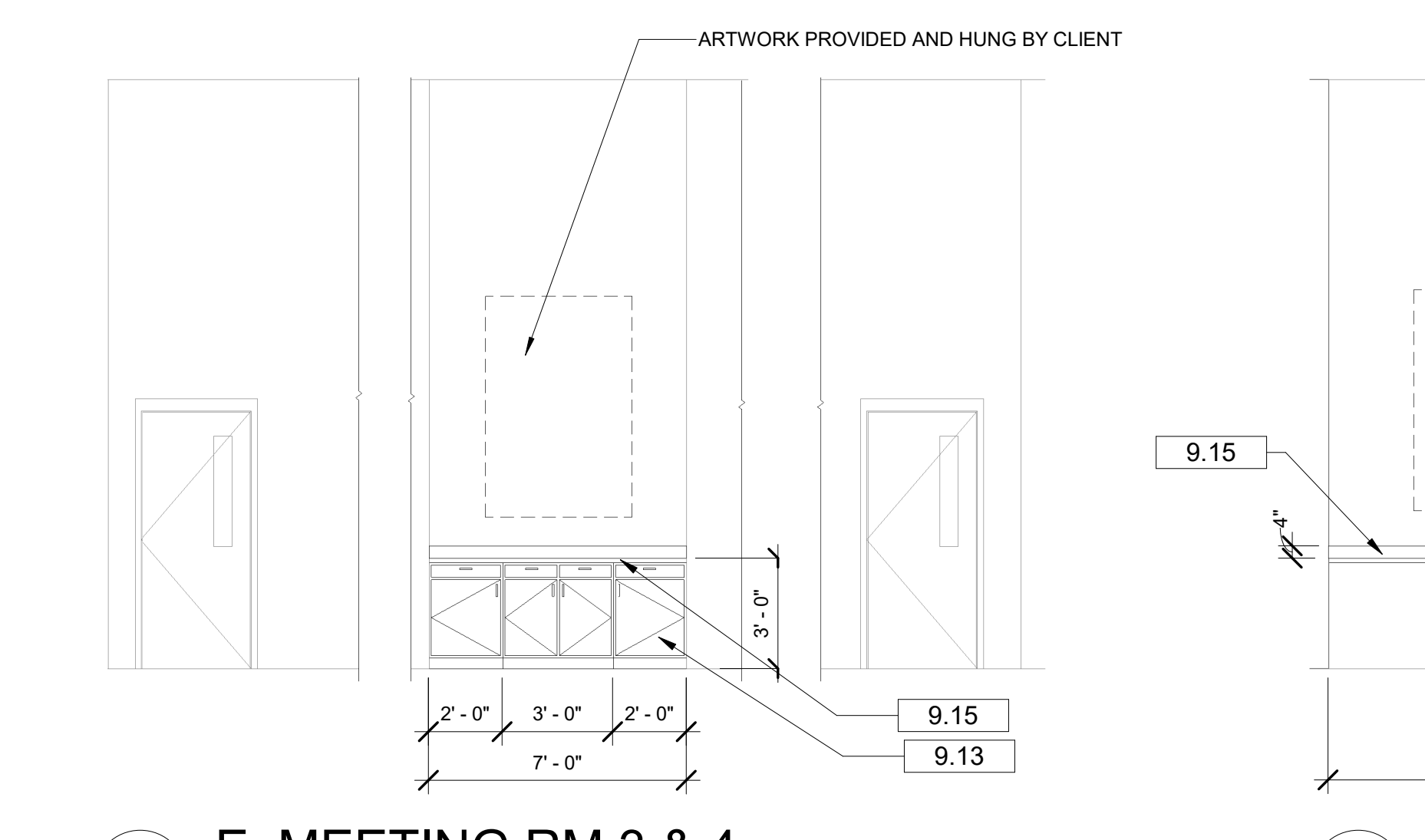

3 E. MEETING RM 3 & 4
 SCALE: 1/4" = 1'-0"

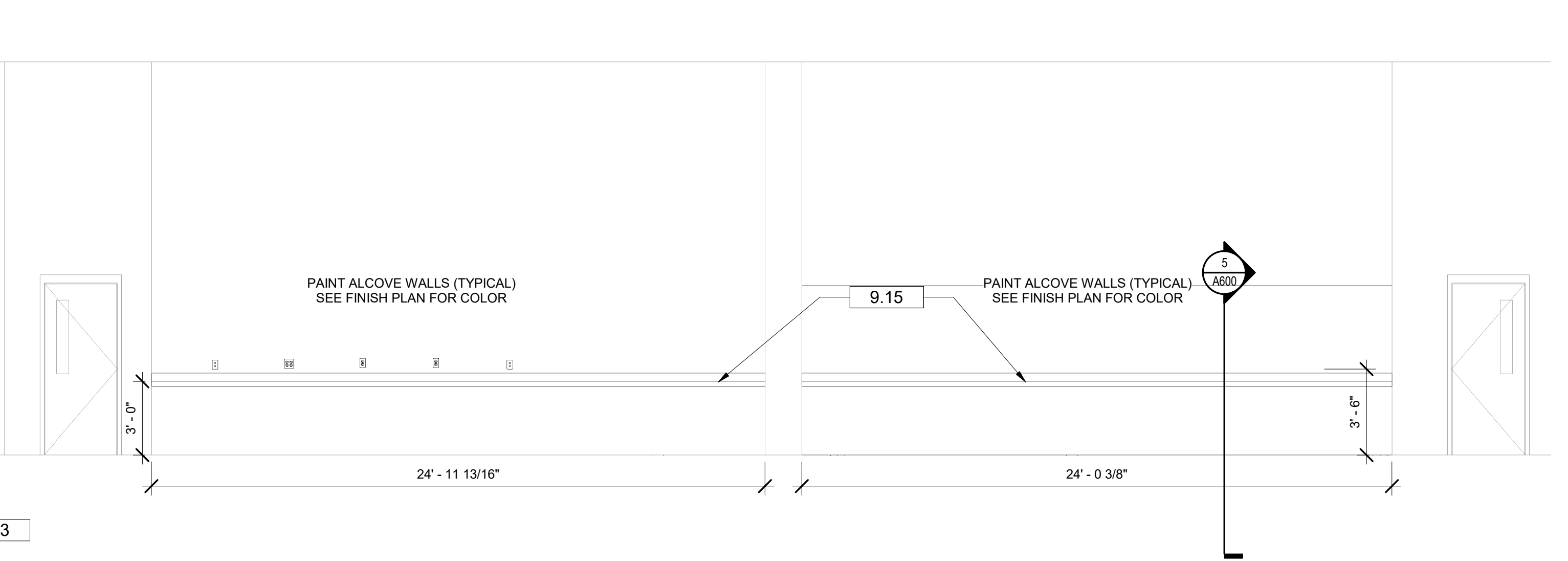

10 W. MEETING RM 5 & 6
 SCALE: 1/4" = 1'-0"

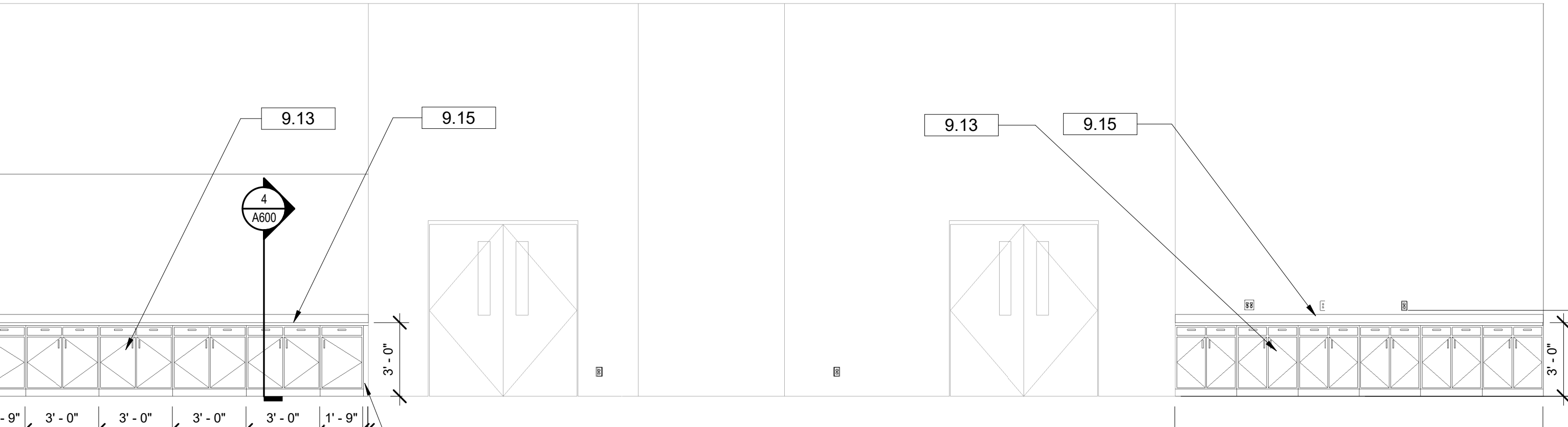

9 E. MEETING RM 5 & 6
 SCALE: 1/4" = 1'-0"

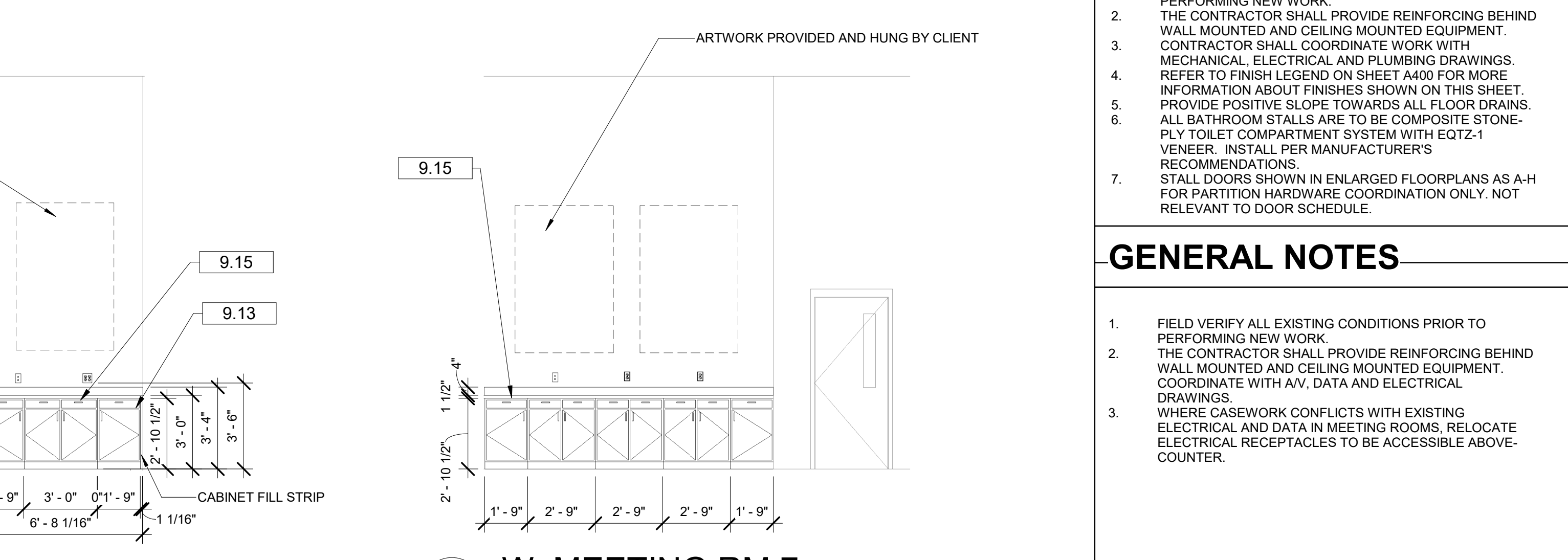

8 W. MEETING RM 7
 SCALE: 1/4" = 1'-0"

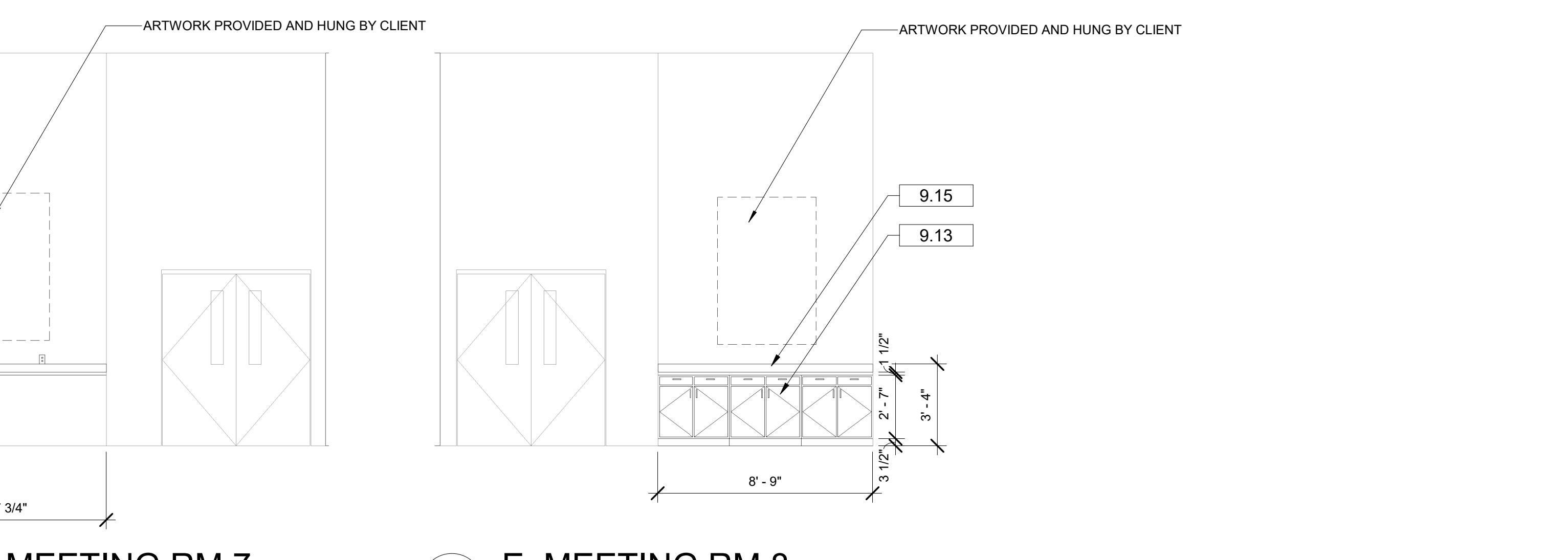

11 E. MEETING RM 8
 SCALE: 1/4" = 1'-0"

GEN. NOTES: ENLG. PLAN

1. FIELD VERIFY ALL EXISTING CONDITIONS PRIOR TO PERFORMING NEW WORK.
2. THE CONTRACTOR SHALL PROVIDE REINFORCING BEHIND WALL MOUNTED AND CEILING MOUNTED EQUIPMENT.
3. CONTRACTOR SHALL COORDINATE WORK WITH MECHANICAL, ELECTRICAL AND PLUMBING DRAWINGS.
4. REFER TO FINISH LEGEND ON SHEET A400 FOR MORE INFORMATION ABOUT FINISHES SHOWN ON THIS SHEET.
5. PROVIDE POSITIVE SLOPE TOWARDS ALL FLOOR DRAINS.
6. ALL BATHROOM STALLS ARE TO BE COMPOSITE STONE-PLY TOILET COMPARTMENT SYSTEM WITH EOTZ-1 VENEER. INSTALL PER MANUFACTURER'S RECOMMENDATIONS.
7. STALL DOORS SHOWN IN ENLARGED FLOORPLANS AS A-H FOR PARTITION HARDWARE COORDINATION ONLY. NOT RELEVANT TO DOOR SCHEDULE.

GENERAL NOTES

1. FIELD VERIFY ALL EXISTING CONDITIONS PRIOR TO PERFORMING NEW WORK.
2. THE CONTRACTOR SHALL PROVIDE REINFORCING BEHIND WALL MOUNTED AND CEILING MOUNTED EQUIPMENT. COORDINATE WITH AV, DATA AND ELECTRICAL DRAWINGS.
3. WHERE CASEWORK CONFLICTS WITH EXISTING ELECTRICAL AND DATA IN MEETING ROOMS, RELOCATE ELECTRICAL RECEPTACLES TO BE ACCESSIBLE ABOVE COUNTER.

KEYNOTES

NUMBER	DESCRIPTION
9.13	PL-1 LAMINATE: WILSONART, SKYLINE WALNUT, STANDARD LAMINATE
9.15	SS-1 SOLID SURFACE: LIVING STONE, SHORELINE #L713

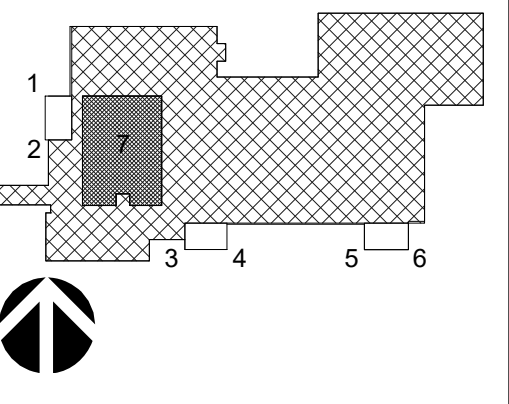

REVISIONS:

No.	Description	Date

ENLARGED - CONFERENCE ROOMS

Project number	17057.5
Dated	JANUARY 2019
PIC	Approver
PM	Designer

A407
 Scale As indicated

GENERAL NOTES

- EXTERIOR FINISHES SHALL MATCH EXISTING BUILDING IN TYPE, SIZE AND COLOR.
- CONTRACTOR SHALL PROVIDE THE GOVERNMENT WITH SAMPLES OF FINISHES FOR APPROVAL.
- REFER TO DOOR AND WINDOW SCHEDULE FOR ADDITIONAL INFORMATION ON SPANDREL GLASS.

KEYNOTES

NUMBER	DESCRIPTION
9.15	SS- 1 SOLID SURFACE: LIVING STONE, SHORELINE #L713
10.05	FEDERAL BRACE: CARRIER GRANITE COUNTERTOP BRACKET
26.11	LED LIGHTING UNDER SINK SYSTEM (ATTACHMENT NOT INCLUDED WITH SINK SYSTEM)

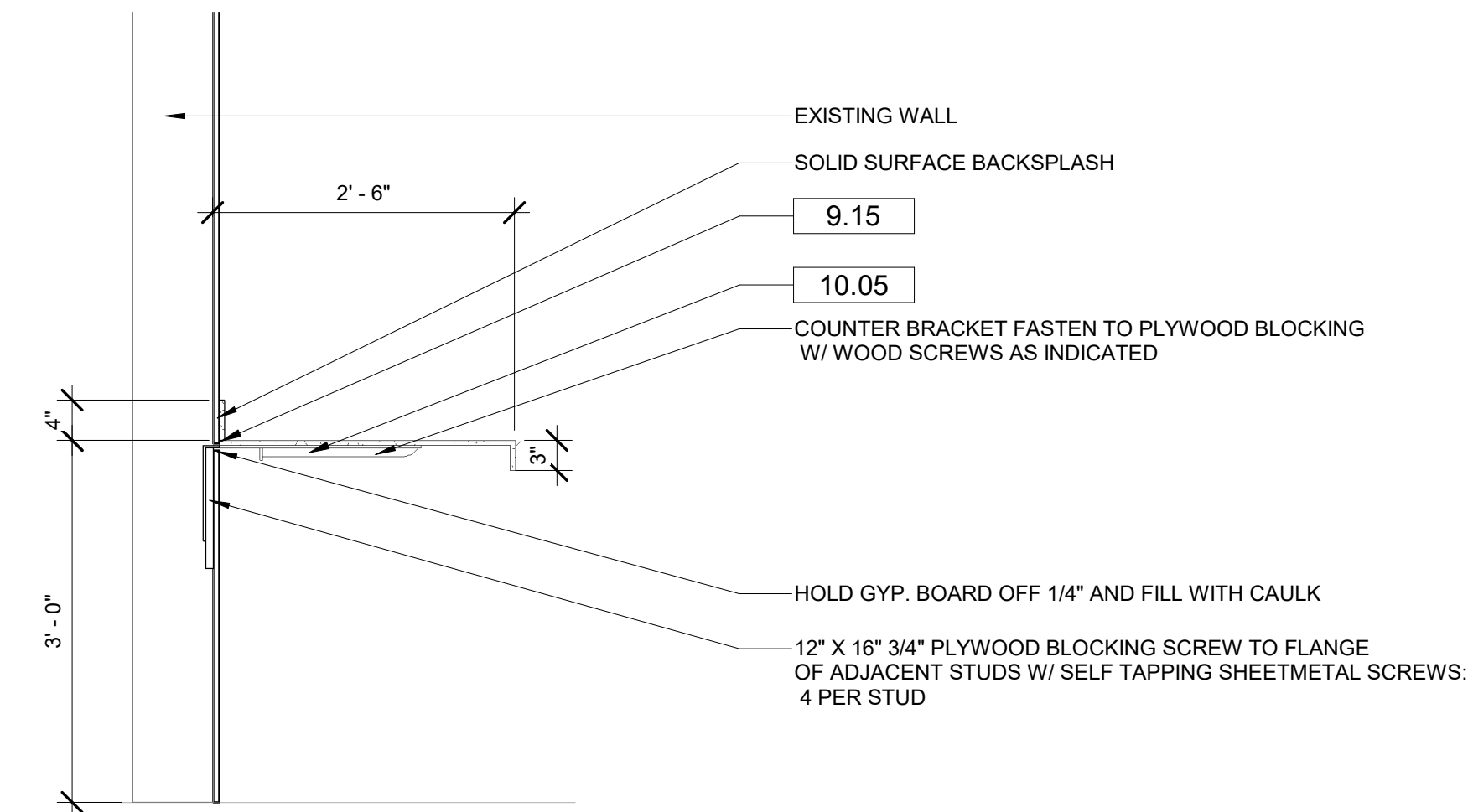

5 MEETING RM. COUNTER
 SCALE: 3/4" = 1'-0"

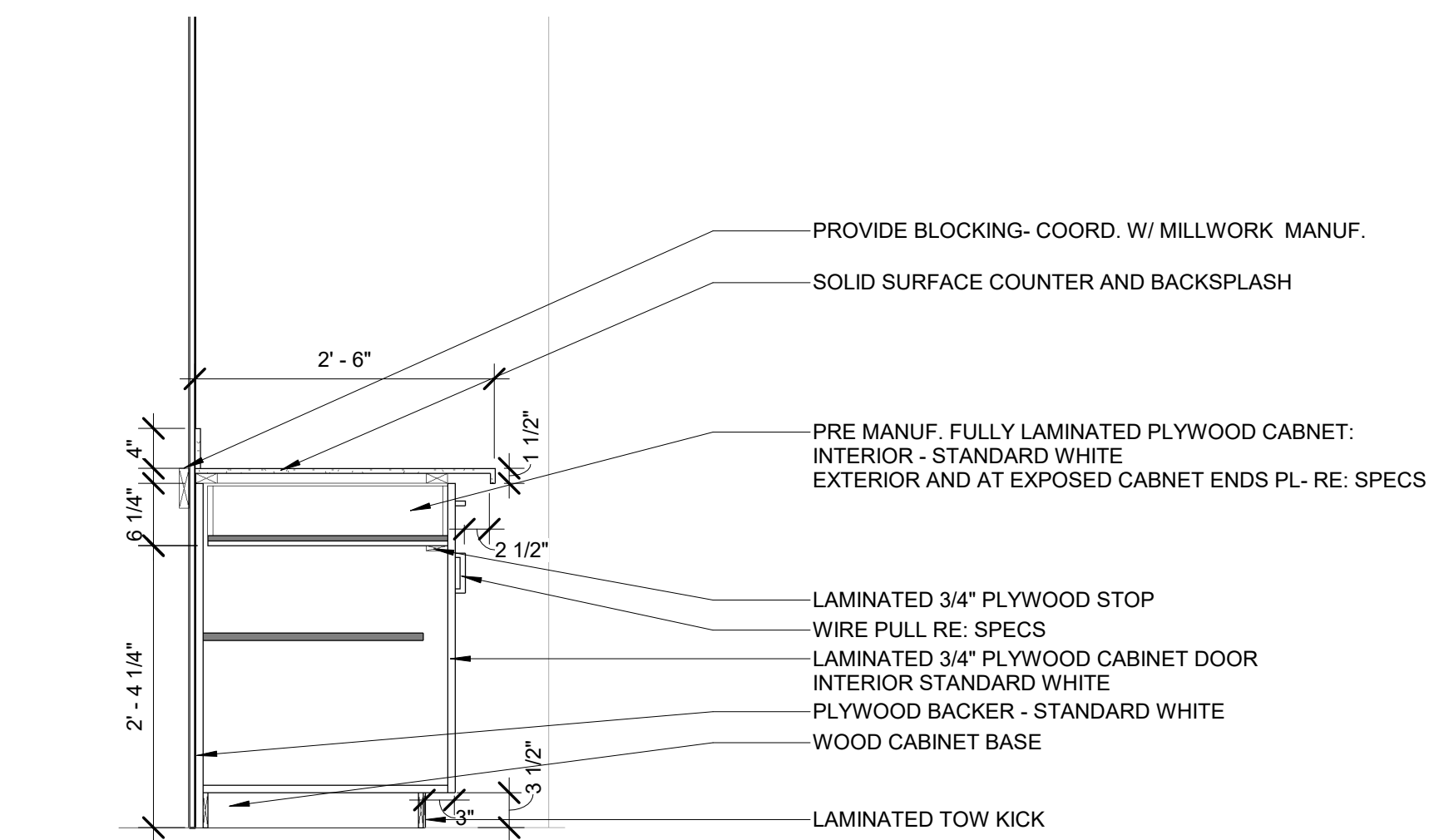

4 MEETING RM. CASEWORK
 SCALE: 3/4" = 1'-0"

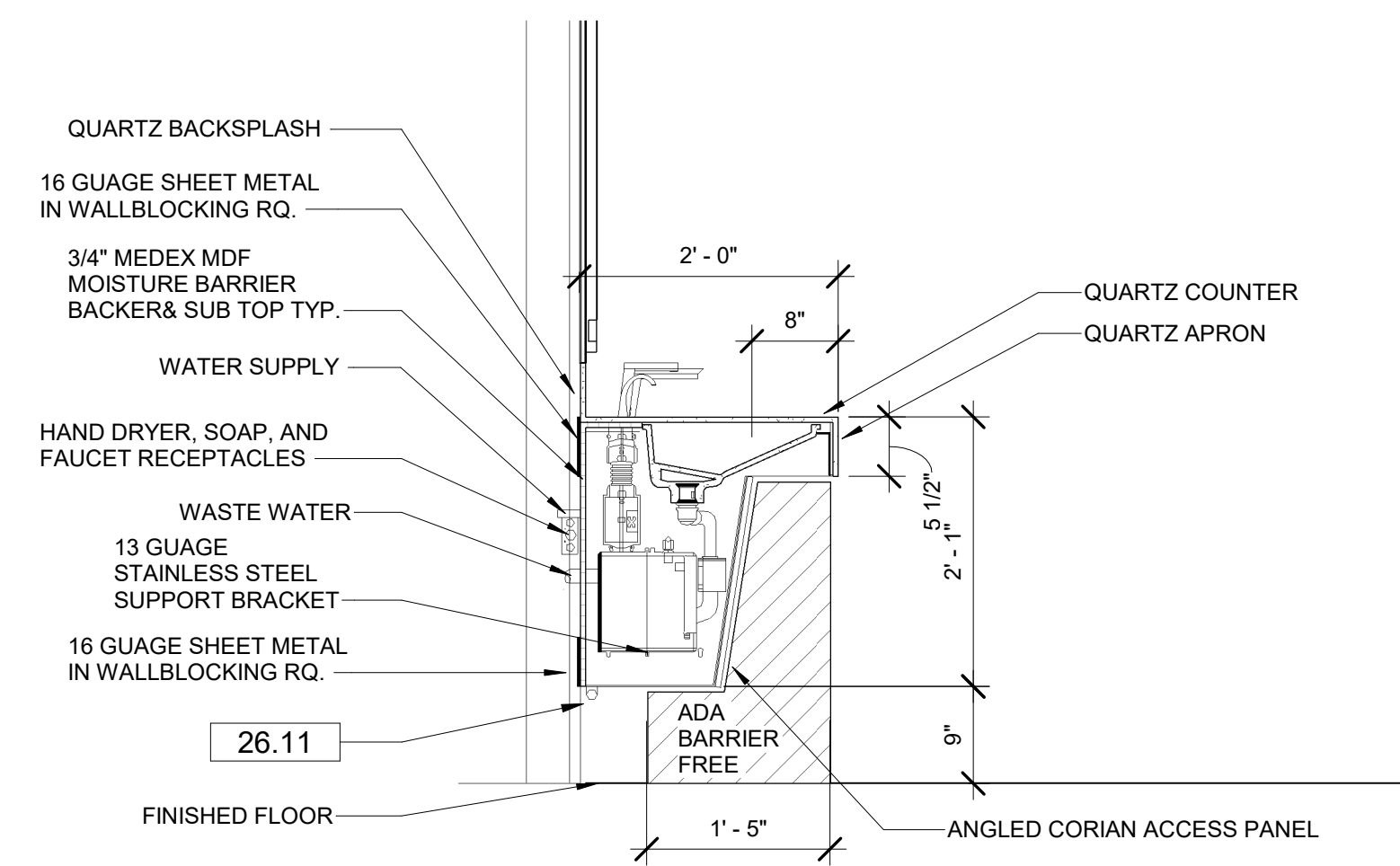

3 DETAIL SECTION AT VANITY
 SCALE: 3/4" = 1'-0"



OWNERSHIP OF SERVICE
 ALL REPORTS, PLANS, SPECIFICATIONS, COMPUTER FILES, FIELD DATA, NOTES AND OTHER DOCUMENTS AND INSTRUMENTS PREPARED BY THE CONSULTANT AS AN INSTRUMENT OF SERVICE SHALL REMAIN THE PROPERTY OF THE CONSULTANT. THE CONSULTANT SHALL RETAIN ALL COMMON LAW, STATUTORY AND OTHER RESERVED RIGHTS. PURSUANT TO FLORIDA STATUTES, SECTION 559.003, AN INDIVIDUAL EMPLOYEE OR AGENT MAY NOT BE HELD INDIVIDUALLY LIABLE FOR NEGLIGENCE.

NOT FOR CONSTRUCTION

BID DOCUMENTS

**EMERALD COAST CONVENTION CENTER
 RESTROOM RENOVATIONS & MEETING ROOM
 COUNTERS**
 TASK ORDER NO. 5 - C-18-2638-TDD
 1250 MIRACLE STRIP PKWY SE
 FORT WALTON BEACH, FL 32548

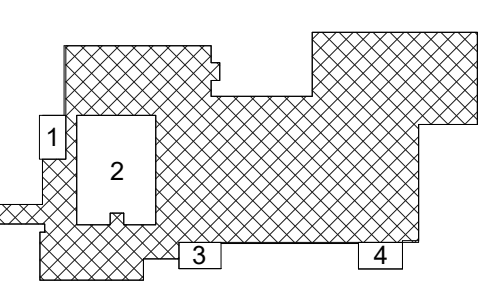

KEY PLAN

REVISIONS:

No.	Description	Date

CASEWORK AND VANITY DETAILS

Project number	17057.5
Dated	JANUARY 2019
PIC	Approver
PM	Designer

A600
 Scale As indicated



OWNERSHIP OF SERVICE
ALL REPORTS, PLANS, SPECIFICATIONS, COMPUTER FILES, FIELD DATA, NOTES AND OTHER DOCUMENTS AND INSTRUMENTS PREPARED BY THE CONSULTANT AS AN INSTRUMENT OF SERVICE SHALL REMAIN THE PROPERTY OF THE CONSULTANT. THE CONSULTANT SHALL RETAIN ALL COMMON LAW, STATUTORY AND OTHER RESERVED RIGHTS, INCLUDING THE COPYRIGHT THEREIN.

PURSUANT TO FLORIDA STATUTES, SECTION 69.055, AN INDIVIDUAL EMPLOYEE OR AGENT MAY NOT BE HELD INDIVIDUALLY LIABLE FOR NEGLIGENCE.

BID DOCUMENTS

**EMERALD COAST CONVENTION CENTER
RESTROOM RENOVATIONS & MEETING ROOM
COUNTERS**
 TASK ORDER NO. 5 - C-18-2638-TDD
 1250 MIRACLE STRIP PKWY SE
 FORT WALTON BEACH, FL 32548

LEGEND

	S or W	SOIL OR WASTE PIPING
	V	VENT PIPING
	CW	COLD WATER SUPPLY PIPING
	HW	HOT WATER SUPPLY PIPING
	HWR	HOT WATER RETURN PIPING
	G	GAS PIPING
	GV	GATE VALVE
	CV	CHECK VALVE
	BV	BALL VALVE
	HB	HOSE BIBB
	WH	WALL HYDRANT
	CO	CLEANOUT TO FLOOR
	FD	FLOOR DRAIN
	COTS	CLEANOUT TO SIDEWALK
	UNION	UNION
	VW	VENT THRU WALL
		SHEET NOTE
		POINT OF CONNECTION TO EXISTING
	WC	WATER CLOSET
	TP	TRAP PRIMER
	EWH	ELECTRIC WATER HEATER
	WHA	WATER HAMMER ARRESTOR TYPE A
	WHB	WATER HAMMER ARRESTOR TYPE B
	WHC	WATER HAMMER ARRESTOR TYPE C
	L	LAVATORY
	UR	URINAL
	KW	KILOWATT
	(E)	EXISTING
	WCO	WALL CLEANOUT
	MR	MOP RECEPTOR
	MV	MIXING VALVE
	WV	WET VENT
	WH	WALL HYDRANT
	HB	HOSE BIBB
	HD	HUB DRAIN WITH EDPM OR SILICON TRAP SEAL
	TW	TEMPERED WATER SUPPLY PIPING
	RTC	RUNNING TRAP CLEANOUT
	UHL-1(M)	EQUIPMENT TAG. (M) INDICATES MECHANICAL EQUIPMENT. REFER TO M SHEETS

PLUMBING FIXTURE SCHEDULE

MARK	FIXTURE	PIPE SIZES-INCHES			REMARKS
		CW	HW	W	
WC-1	WATER CLOSET (HANDICAP, ELECTRONIC)	1	-	4	HANDICAP HEIGHT @ 17", WALL MOUNT, ELONGATED BOWL, 1-1/2" TOP SPUD, 1.1 GPF, HARDWIRED SENSOR OPERATED WITH MANUAL OVERRIDE, OPEN FRONT SEAT LESS COVER
WC-2	WATER CLOSET (STANDARD, ELECTRONIC)	1	-	4	STANDARD HEIGHT @ 15", WALL MOUNT, ELONGATED BOWL, 1-1/2" TOP SPUD, 1.1 GPF, HARDWIRED SENSOR OPERATED WITH MANUAL OVERRIDE, OPEN FRONT SEAT LESS COVER
UR-1	URINAL (ELECTRONIC)	3/4	-	2	WALL MOUNT, CARRIER, HARD WIRED SENSOR OPERATED FLUSH VALVE WITH MANUAL OVERRIDE, 3/4" TOP SPUD, COORDINATE WITH ARCH. DWGS, 0.125 GPF
UR-2	URINAL (HANDICAP, ELECTRONIC)	3/4	-	2	WALL MOUNT, CARRIER, HARD WIRED SENSOR OPERATED FLUSH VALVE WITH MANUAL OVERRIDE, 3/4" TOP SPUD, COORDINATE WITH ARCH. DWGS, 0.125 GPF
L-1	LAVATORY (HANDICAP, 20"x18")	3/8	3/8	1-1/4	WALL MOUNT, CHAIR CARRIER, VITREOUS CHINA, CENTER HOLE, INSULATION KIT, MIXING VALVE, POLISHED CHROME PLATED FAUCET, SENSOR OPERATED, 0.5 GPM, P-TRAP, TAILPIECE, STOPS & SUPPLIES
L-2	INTEGRATED SINK (3 STATION)	3/8	3/8	1-1/4	WALL MOUNT, ELECTRONIC HAND DRYER, FAUCET, SOAP DISPENSER FOR EACH STATION. TAILPIECE, STOPS AND SUPPLIES FOR EACH STATION. 0.5 GPM FAUCET, 4.5 AMP HAIR DRYER WITH NO HEAT
L-3	INTEGRATED SINK (1 STATION)	3/8	3/8	1-1/4	WALL MOUNT, ELECTRONIC HAND DRYER, FAUCET, SOAP DISPENSER FOR EACH STATION. TAILPIECE, STOPS AND SUPPLIES FOR EACH STATION. 0.5 GPM FAUCET, 4.5 AMP HAIR DRYER WITH NO HEAT
EWC-1	ELECTRIC WATER COOLER (DUAL LEVEL)	3/8	-	1-1/4	IN WALL MOUNT, CHAIR CARRIER, DUAL LEVEL, SELF CONTAINED, STAINLESS STEEL, PUSH BUTTON
EWC-1	ELECTRIC WATER COOLER - ADD ALTERNATE (DUAL LEVEL)	3/8	-	1-1/4	IN WALL MOUNT, CHAIR CARRIER, DUAL LEVEL, SELF CONTAINED, STAINLESS STEEL, PUSH BUTTON, SENSOR ACTIVATED BOTTLE FILL STATION
LD-1	LINEAR DRAIN (5-1/2"x13")	-	-	3	PERFORATED GRATE, STAINLESS STEEL, DEEP SEAL, TRAP PRIMER CONNECTION
WH	RECESSED WALL HYDRANT / HOSE BIB	3/4	-	-	FLUSH MOUNTING WALL BOX, BRASS, CHROME FINISH, ANTI-SIPHON VACUUM BREAKER, DUAL CHECK VALVE, INTEGRAL SERVICE SHUT-OFF VALVE, WHEEL HANDLE (ACORN #160)

- WATER SUPPLY TAPPING TO EACH PLUMBING FIXTURE SHALL BE FULL SIZE (MINIMUM).
- SEE ELECTRICAL DWGS FOR FINAL POWER REQUIREMENTS.
- PROVIDE WATER HAMMER ARRESTORS ON HOT AND COLD WATER SUPPLY BRANCHES SERVING SINGULAR, MULTIPLE, OR GROUPS OF PLUMBING FIXTURES. ADHERENCE TO THE PLUMBING AND DRAINAGE INSTITUTE STANDARD P.D.I.-WH201 (PER SPECIFICATIONS) SHALL BE EMPLOYED IN DETERMINING PROPER SIZE, SELECTION, PLACEMENT, LOCATION, AND INSTALLATION OF ARRESTORS.

GENERAL NOTES

- COORDINATE ALL PIPING WITH DUCTWORK SHOP DRAWINGS AND EXISTING CONDITIONS. ROUTE PIPING AS REQUIRED TO AVOID CONFLICTS.
- ALL PIPING PASSING THROUGH ANY WALL SHALL HAVE A SLEEVE PER SPECIFICATIONS.
- ALL PIPING PASSING THROUGH FIRE-RATED WALLS SHALL HAVE A FIRE-RATED SLEEVE PER SPECIFICATIONS. ALL PIPING PENETRATIONS THROUGH WALLS OR FLOORS SHALL BE SEALED TO EQUAL THE RATING OF THE WALLS OR FLOORS.
- ALL PIPING INDICATED IS ABOVE THE CEILING EXCEPT THE OBVIOUS SANITARY SOIL, WASTE, VENT AND POTABLE WATER PIPING BELOW FLOOR OR GRADE.
- SEE TOILET ROOM ELEVATIONS ON ARCHITECTURAL DRAWINGS FOR PLUMBING FIXTURE MOUNTING HEIGHT.
- COORDINATE EXACT LOCATION OF ALL EXTERIOR WALL HYDRANTS WITH ARCHITECTURAL DRAWINGS.
- PRIOR TO SUBSTANTIAL COMPLETION OF NEW AND ALTERED WORK AREAS, CONTRACTOR SHALL HAVE SANITARY PLUMBING SYSTEM CLEARED OF DEBRIS OR ANY MATTER THAT WOULD INTERFERE OR PREVENT ADEQUATE CONVEYANCE OF MATERIALS FROM MOVING THROUGH AND TERMINATING INTO BUILDING OR PUBLIC DISPOSAL FACILITIES.
- ALL WORK SHALL COMPLY WITH THE FLORIDA BUILDING CODE - PLUMBING SIXTH EDITION (2017).
- REFER TO M301 AND M302 FOR PIPE PENETRATIONS OF NEW FIRE WALLS.

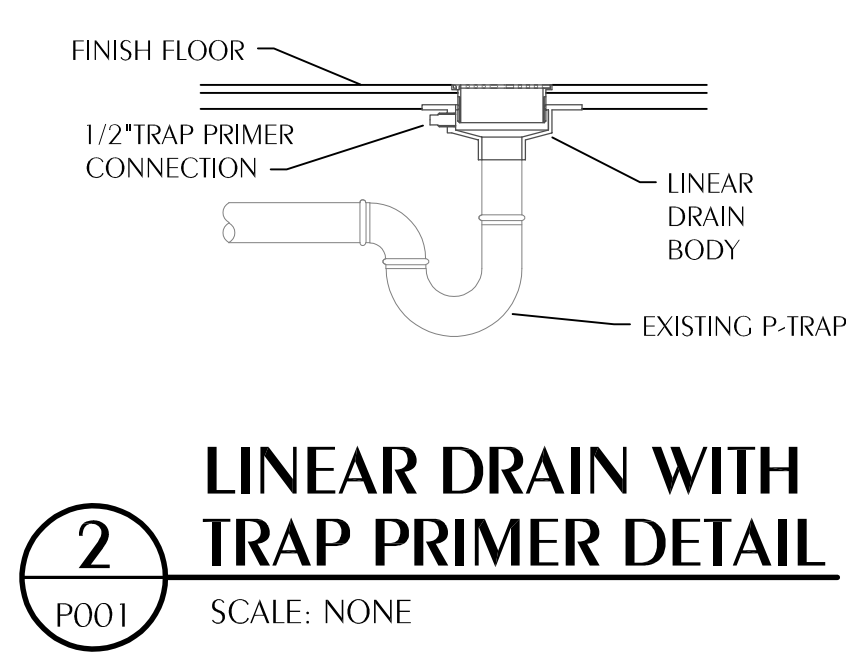
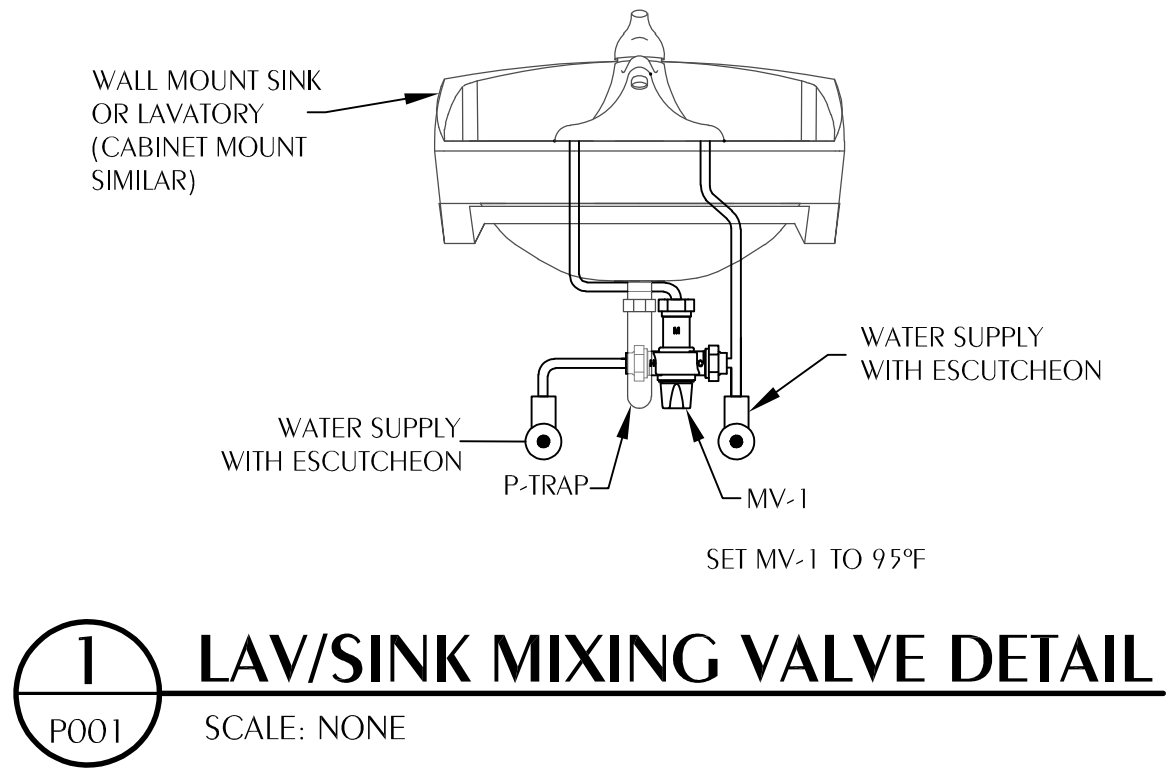

REVISIONS:

No.	Description	Date

PLUMBING LEGEND, SCHEDULE, DETAILS, & NOTES

Project number	17057.5
Dated	JANUARY 2019
PLC	DNW
PM	KAJ

P001
Scale NONE

Watford Engineering, Inc.
Mechanical Consulting
4471 Clinton Street
Maitland, FL 32747
Florida CA Number: 27825
Project Number: 2018-021
T: 850-526-3447
F: 850-526-3448
David N. Watford, PE
FL License Number: #8208

PLUMBING SPECIFICATIONS

1. **GENERAL**
 - A. THE CONTRACTOR SHALL FURNISH ALL LABOR, MATERIALS, TOOLS, EQUIPMENT, AND PERFORM ALL WORK AND SERVICES FOR ALL PLUMBING AS SHOWN ON DRAWINGS AND AS SPECIFIED, IN ACCORDANCE WITH PROVISIONS OF THE CONTRACT DOCUMENTS, AND COMPLETELY COORDINATED WITH WORK OF ALL OTHER TRADES.
 - B. ALTHOUGH SUCH WORK IS NOT SPECIFICALLY INDICATED, FURNISH AND INSTALL ALL SUPPLEMENTARY OR MISCELLANEOUS ITEMS, APPURTENANCES AND DEVICES INCIDENTAL TO OR NECESSARY FOR A SOUND, SECURE AND COMPLETE INSTALLATION.
2. **SCOPE OF WORK**
 - A. THE WORK INCLUDES THE FOLLOWING ITEMS BUT IS NOT NECESSARILY LIMITED TO THESE:
 1. ALL POTABLE WATER, DRAIN, WASTE AND VENT PIPING FOR COMPLETE PLUMBING SYSTEM.
 2. ALL WASTE AND DRAIN PIPING INCLUDING CONNECTING INTO EXISTING SERVICES.
 3. ALL MATERIALS, EQUIPMENT, FIXTURES, ACCESSORIES AND TRIM, TO MAKE A COMPLETE FINISHED INSTALLATION.
 4. NECESSARY TRENCHING AND BACKFILLING TO INSTALL THE PLUMBING SYSTEM.
 5. ALL INSULATION AS SPECIFIED HEREIN.
3. **SITE INSPECTION**
 - A. BEFORE SUBMITTING PROPOSALS, EACH BIDDER SHALL VISIT THE SITE AND FULLY FAMILIARIZE HIMSELF WITH ALL JOB CONDITIONS AND SHALL BE FULLY INFORMED AS TO THE EXTENT OF WORK.
4. **QUALITY OF MATERIALS AND APPROVALS**
 - A. THE FIXTURES AND EQUIPMENT ARE SPECIFIED BY MANUFACTURER AND MODEL NUMBER FOR THE PURPOSE OF ESTABLISHING TYPE AND QUALITY REQUIRED. OTHER MANUFACTURER'S PRODUCTS OF EQUAL QUALITY AND TYPE, AS DETERMINED BY THE ARCHITECT, MAY BE USED WHEN APPROVED.
5. **TESTS**
 - A. CONCEALED WORK SHALL REMAIN UNCOVERED UNTIL REQUIRED TESTS HAVE BEEN COMPLETED. TESTS SHALL BE REPEATED AFTER DEFECTS HAVE BEEN ELIMINATED.
 - B. DRAIN SYSTEMS: A WATER TEST SHALL BE APPLIED TO ALL PARTS OF THE DRAINAGE SYSTEM BEFORE THE PIPES ARE CONCEALED OR FITTINGS SET IN PLACE.
 - C. STERILIZATION: THE ENTIRE WATER DISTRIBUTION SYSTEM SHALL BE THOROUGHLY STERILIZED WITH SOLUTION CONTAINING NOT LESS THAN 50 PARTS PER MILLION OF AVAILABLE CHLORINE. THE REPRESENTATIVE OPERATION SHALL BE APPROVED BY THE STATE BOARD OF HEALTH REPRESENTATIVE.
6. **PIPE AND FITTINGS**
 - A. WASTE, VENT AND DRAIN PIPING:
 1. PIPING BELOW SLAB SHALL BE SERVICE WEIGHT CAST - IRON WITH BELL AND SPIGOT - LEAD CAULKED. BELL AND SPIGOT NEOPRENE PUSH TYPE GASKET, OR "NO - HUB" JOINTS. PIPE AND FITTINGS SHALL BE COATED INSIDE AND OUTSIDE WITH COAL - TAR VARNISH. "NO - HUB" JOINTS BELOW SLAB SHALL BE MADE USING TYPE MC CAST IRON COUPLINGS ONLY. CONTRACTOR'S OPTION, MAY UTILIZE PVC PIPE AND FITTINGS.
 2. PIPING ABOVE THE SLAB SHALL BE SERVICE WEIGHT CAST - IRON WITH BELL AND SPIGOT LEAD CAULKED OR "NO - HUB" JOINTS OR PVC-DMW PIPE AND FITTINGS. VENT PIPING MAY BE SCHEDULE 40 GALVANIZED STEEL WITH MALLEABLE FITTINGS. CONTRACTOR'S OPTION, MAY UTILIZE PVC PIPE AND FITTINGS.
 - B. WATER PIPING:
 1. WATER PIPING SHALL BE COPPER TUBING, TYPE "K" (SOFT UP TO 1-INCH, OVER 1-INCH TO BE HARD) BELOW SLAB AND TYPE "L" ABOVE SLAB, WITH SWEAT FITTINGS.
 2. WATER PIPING MORE THAN FIVE FEET OUTSIDE BUILDING SHALL BE TYPE "K" COPPER.
7. **PLASTIC PIPE**
 - A. CONTRACTOR MAY, AS INDICATED IN THESE SPECIFICATIONS, USE SCHEDULE 40 PVC FOR SANITARY DRAIN AND VENT IN ALL AREAS EXCEPT OVERHEAD IN THE PARKING GARAGE.
 - B. MATERIALS: PVC PIPE SHALL BE SCHEDULE 40 PIPE AND FITTINGS PRODUCED FROM MATERIAL CONFORMING TO ASTM D 1784, TYPE I, GRADE I, 200 PSI DESIGN STRESS (PVC 1120).
8. **INSULATION**
 - A. GENERAL: ALL INSULATION WORK SHALL BE DONE BY WORKMEN THOROUGHLY COMPETENT IN THIS TRADE. B. THE FOLLOWING SHALL BE INSULATED AS INDICATED:
 1. DOMESTIC COLD WATER PIPING AND FITTINGS AND ALL HOT WATER PIPING AND FITTINGS: 3/4" IN. THICK PREFORMED FIBERGLASS WITH FACTORY JACKET OR 3/4 IN. THICK FOAMED PLASTIC, FIRE RESISTANT, PROVIDE SMOOTH WHITE PVC JACKET FOR INSULATION EXPOSED INSIDE FINISHED SPACES.
9. **INSTALLATION OF PIPING SYSTEMS**
 - A. GRADE: ALL BUILDING SEWERS SHALL HAVE A UNIFORM GRADE OF NOT LESS THAN 1/8 IN. TO THE FOOT, DOWNWARD IN DIRECTION OF FLOW FOR PIPE 3 IN. AND LARGER. PIPE SMALLER THAN 3 IN. SHALL HAVE GRADE OF 1/4 IN. TO THE FOOT.
 - B. CLEANOUTS: ALL CLEANOUT PLUGS SHALL BE RECESSED BRASS TYPE.
 1. CLEANOUTS TO FINISHED FLOORS SHALL BE EQUAL TO JOSAM SERIES 56000-18-41 (-12, -14), BRONZE PLUG, CLAMP FLANG AND FLANGE, LEVELIZE ADJUSTABLE HOUSING AND WITH SATIN FINISH BRONZE COVER AND FRAME. CLEANOUTS IN FINISHED WALLS SHALL BE EQUAL TO JOSAM SERIES 58890, WITH POLISHED STAINLESS STEEL COVER AND SECURING SCREWS.
 2. CLEANOUTS TO GRADE SHALL BE WITH LEAD CAULKED CAST-IRON FITTINGS WITH BRASS COUNTERSINK PLUG, JOSAM 58460 SET IN A 24 IN. SQUARE BLOCK OF POURED CONCRETE, 6 IN. THICK. ALL EXTERIOR CLEANOUTS SHALL BE BROUGHT TO GRADE. PVC SHALL NOT BE USED FOR CLEANOUTS TO GRADE.
 - C. PIPE SUPPORT:
 1. ALL HORIZONTAL SUSPENDED PIPE SHALL BE SUPPORTED AS REQUIRED IN SECTION 308 OF THE 2010 FLORIDA BUILDING CODE-PLUMBING.
 - D. PROTECTION OF PIPING SYSTEMS:
 1. ALL PIPING AND PLUMBING SYSTEM COMPONENTS SHALL BE PROTECTED IN ACCORDANCE WITH SECTION 305 OF THE 2010 FLORIDA BUILDING CODE-PLUMBING.
10. **INSTALLATION OF FIXTURES AND EQUIPMENT**
 - A. PREPARATIONS OF ROUGH-IN, SUPPORTS AND WALL FINISHES SHALL BE COMPLETED AND TESTED OR INSPECTED BEFORE FIXTURES OR EQUIPMENT ARE INSTALLED.
 - B. INSTALLATION:
 1. MECHANICAL OR PLUMBING CONNECTIONS SHALL BE MADE WITH CORRECT FITTINGS, GASKETS OR SETTING COMPOUND FOR EACH FIXTURE. SEAL ALL BRASS AND TRIM TO WALLS AND FIXTURES WITH RESILIENT WATERPROOF COMPOUND.
11. **START-UP SERVICE**

- A. THE CONTRACTOR SHALL PUT ALL ITEMS INSTALLED UNDER THIS SECTION INTO OPERATION AND SHALL INSTRUCT THE OWNER'S MAINTENANCE PERSONNEL IN ALL POINTS.
12. **GUARANTEE**
 - A. THE CONTRACTOR SHALL GUARANTEE ALL WORK IN THIS SECTION FOR A PERIOD OF ONE YEAR FROM DATE OF ACCEPTANCE AGAINST DEFECTS DUE TO FAULTY WORKMANSHIP OR MATERIALS.
13. **FIXTURES AND EQUIPMENT**
 - A. FURNISH AND INSTALL PLUMBING FIXTURES, EQUIPMENT, DRAINS, ETC., COMPLETE WITH ALL TRIM, FITTINGS, AND OTHER DEVICES WHICH ARE CONSIDERED NECESSARY BY THE TRADE, BY CRAT STANDARDS AND/OR BY THE ARCHITECT.
14. **PLUMBING, FIXTURES, EQUIPMENT AND TRIM**
 - WC-1 WATER CLOSET, WALL MOUNTED (HANDICAP, ELECTRONIC VALVE):

VITREOUS CHINA, 1.1 GALLONS PER FLUSH, ELONGATED, SIPHON JET, WHITE, WITH 1-1/2" TOP SPUD, 15" HIGH. PROVIDE QUIET CONCEALED DIAPHRAGM TYPE ELECTRONIC A/DVC MOTOR ACTUATOR, SENSOR AND OVER-RIDE BUTTON, CHECK ANGLE STOP, NON-HOLD, OPEN FEATURE, ADJUSTABLE TAILPIECE, SPUD COUPLING AND FLANGES, VACUUM BREAKER, CHROME PLATED WALL COVER PLATES WITH VANDAL RESISTANT SCREWS, ALL EXPOSED PARTS CHROME PLATED, HARDWIRED WITH 7 A VDC POWER CONVERTER, CONTROL CIRCUIT SHALL BE SOLID STATE 24V INPUT AND OUTPUT INITIATING DELAY FUNCTIONS, TRANSFORMER, 120V PRIMARY, 24V SECONDARY, UL LISTED SERVING UP TO TEN CLOSET VALVES, COORDINATE TRANSFORMER WITH MAXIMUM NUMBER OF VALVES FURNISHED, LOW VOLTAGE WIRING PROVIDED AND INSTALLED BY ELECTRICAL CONTRACTOR. HEAVY MOLDDED PLASTIC, WHITE, ELONGATED, OPEN FRONT SEAT LESS COVER, WITH STAINLESS STEEL SELF-SUSPENDING CHECK HINGES, HOLD CENTERLINE FLUSH VALVE ASSEMBLY OFF FINISH WALL FOR GRAB BAR CLEARANCES, COORDINATE WITH ARCHITECTURAL DRAWINGS, FURNISH VERTICAL FLOOR MOUNTED CARRIER WITH UNIVERSAL FOOT SUPPORTS, ADJUSTABLE ABS COUPLING, REAR ANCHOR TIE DOWN AND BONDED NEO-SEAL GASKET, CONFORMING TO FEDERAL SPEC. FF-S-323.	WATER CLOSET	ZURN Z5615-BWL
VALVE	ZURN ZEM6000AV-ONE-IS	
SEAT	Z59355S-EL-S1S	
NEO-SEAL GASKET KIT	ZURN Z5977-NEO	
POWER CONVERTER	ZURN P-6000-HW6	
CARRIER	ZURN Z-1200H, HD, N, ND	
 - WC-2 WATER CLOSET, WALL MOUNTED (STANDARD, ELECTRONIC VALVE):

VITREOUS CHINA, 1.1 GALLONS PER FLUSH, ELONGATED, SIPHON JET, WHITE, WITH 1-1/2" TOP SPUD, 15" HIGH. PROVIDE QUIET CONCEALED DIAPHRAGM TYPE ELECTRONIC A/DVC MOTOR ACTUATOR, SENSOR AND OVER-RIDE BUTTON, CHECK ANGLE STOP, NON-HOLD-OPEN FEATURE, ADJUSTABLE TAILPIECE, SPUD COUPLING AND FLANGES, VACUUM BREAKER, CHROME PLATED WALL COVER PLATES WITH VANDAL RESISTANT SCREWS, ALL EXPOSED PARTS CHROME PLATED, HARDWIRED WITH 7 A VDC POWER CONVERTER, CONTROL CIRCUIT SHALL BE SOLID STATE 24V INPUT AND OUTPUT INITIATING DELAY FUNCTIONS, TRANSFORMER, 120V PRIMARY, 24V SECONDARY, UL LISTED SERVING UP TO TEN CLOSET VALVES, COORDINATE TRANSFORMER WITH MAXIMUM NUMBER OF VALVES FURNISHED, LOW VOLTAGE WIRING PROVIDED AND INSTALLED BY ELECTRICAL CONTRACTOR. HEAVY MOLDDED PLASTIC, WHITE, ELONGATED, OPEN FRONT SEAT LESS COVER, WITH STAINLESS STEEL SELF-SUSPENDING CHECK HINGES, HOLD CENTERLINE FLUSH VALVE ASSEMBLY OFF FINISH WALL FOR GRAB BAR CLEARANCES, COORDINATE WITH ARCHITECTURAL DRAWINGS, FURNISH VERTICAL FLOOR MOUNTED CARRIER WITH UNIVERSAL FOOT SUPPORTS, ADJUSTABLE ABS COUPLING, REAR ANCHOR TIE DOWN AND BONDED NEO-SEAL GASKET, CONFORMING TO FEDERAL SPEC. FF-S-323.	WATER CLOSET	ZURN Z5615-BWL
VALVE	ZURN ZEM6000AV-ONE-IS	
SEAT	Z59355S-EL-S1S	
NEO-SEAL GASKET KIT	ZURN Z5977-NEO	
POWER CONVERTER	ZURN P-6000-HW6	
CARRIER	ZURN Z-1200H, HD, N, ND	
 - UR-1 URINAL, WALL-MOUNT (STANDARD, ELECTRONIC VALVE):

VITREOUS CHINA, 0.125 GALLONS PER FLUSH, SIPHON JET FLUSH, FOR 3/4" EXPOSED TOP SPUD URINAL STRAINER, 27 L.P.S., OUTLET FLANGE & RUBBER GASKET WITH INTEGRAL TRAP. PROVIDE QUIET CONCEALED DIAPHRAGM TYPE ELECTRONIC 24 VOLT SOLENOID OPERATOR, SENSOR AND OVER-RIDE BUTTON, CHECK ANGLE STOP, NON-HOLD-OPEN FEATURE, ADJUSTABLE TAILPIECE, SPUD COUPLING AND FLANGES, VACUUM BREAKER, CHROME PLATED WALL COVER PLATES WITH VANDAL RESISTANT SCREWS, ALL EXPOSED PARTS CHROME PLATED, HARDWIRED WITH 7 A VDC POWER CONVERTER, CONTROL CIRCUIT SHALL BE SOLID STATE 24V INPUT AND OUTPUT INITIATING DELAY FUNCTIONS, TRANSFORMER, 120V PRIMARY, 24V SECONDARY, UL LISTED SERVING UP TO TEN URINAL VALVES, COORDINATE TRANSFORMER WITH MAXIMUM NUMBER OF VALVES FURNISHED, LOW VOLTAGE WIRING PROVIDED AND INSTALLED BY ELECTRICAL CONTRACTOR. FURNISH FLOOR MOUNTED SINGLE CARRIER WITH HANGER PLATE, BEARING PLATE, ADJUSTABLE SUPPORTING RODS, STRUCTURAL UPRIGHTS AND BLOCK BASES, SECURE BASE TO FLOOR FOR RIGID CONNECTION WITH 1/2" X 3-3/4" THREADED ZINC PLATED STEEL HEAVY DUTY WEDGE ANCHORS, COMPLETE WITH STAINLESS STEEL CLIP, WASHER AND THREADED NUT, CONFORMING TO FEDERAL SPEC. FF-S-323. COORDINATE MOUNTING HEIGHT WITH ARCHITECTURAL DRAWINGS.	URINAL	ZURN Z5708
VALVE	ZURN ZEM56195AV-ULF-IS	
URINAL FLANGE KIT	ZURN Z5976-URINAL	
POWER CONVERTER	ZURN P-6000-HW6	
CARRIER	ZURN Z-1222	
BASE ANCHORAGE	B-LINE ANCHORS AWA-50-375	
 - UR-2 URINAL, WALL-MOUNT (HANDICAP, ELECTRONIC VALVE):

VITREOUS CHINA, 0.125 GALLONS PER FLUSH, SIPHON JET FLUSH, FOR 3/4" EXPOSED TOP SPUD URINAL STRAINER, 27 L.P.S., OUTLET FLANGE & RUBBER GASKET WITH INTEGRAL TRAP. PROVIDE QUIET CONCEALED DIAPHRAGM TYPE ELECTRONIC 24 VOLT SOLENOID OPERATOR, SENSOR AND OVER-RIDE BUTTON, CHECK ANGLE STOP, NON-HOLD-OPEN FEATURE, ADJUSTABLE TAILPIECE, SPUD COUPLING AND FLANGES, VACUUM BREAKER, CHROME PLATED WALL COVER PLATES WITH VANDAL RESISTANT SCREWS, ALL EXPOSED PARTS CHROME PLATED, HARDWIRED WITH 7 A VDC POWER CONVERTER, CONTROL CIRCUIT SHALL BE SOLID STATE 24V INPUT AND OUTPUT INITIATING DELAY FUNCTIONS, TRANSFORMER, 120V PRIMARY, 24V SECONDARY, UL LISTED SERVING UP TO TEN URINAL VALVES, COORDINATE TRANSFORMER WITH MAXIMUM NUMBER OF VALVES FURNISHED, LOW VOLTAGE WIRING PROVIDED AND INSTALLED BY ELECTRICAL CONTRACTOR. FURNISH FLOOR MOUNTED SINGLE CARRIER WITH HANGER PLATE, BEARING PLATE, ADJUSTABLE SUPPORTING RODS, STRUCTURAL UPRIGHTS AND BLOCK BASES, SECURE BASE TO FLOOR FOR RIGID CONNECTION WITH 1/2" X 3-3/4" THREADED ZINC PLATED STEEL HEAVY DUTY WEDGE ANCHORS, COMPLETE WITH STAINLESS STEEL CLIP, WASHER AND THREADED NUT, CONFORMING TO FEDERAL SPEC. FF-S-323. MOUNT TO SATISFY ADA REQUIREMENTS, COORDINATE WITH ARCHITECTURAL DRAWINGS (TOILET ROOM ELEVATIONS) FOR FINAL MOUNTING HEIGHT.	URINAL	ZURN Z5708
VALVE	ZURN ZEM56195AV-ULF-IS	
URINAL FLANGE KIT	ZURN Z5976-URINAL	
POWER CONVERTER	ZURN P-6000-HW6	
CARRIER	ZURN Z-1222	
BASE ANCHORAGE	B-LINE ANCHORS AWA-50-375	
 - L-1 LAVATORY, WALL MOUNT (HANDICAP):

VITREOUS CHINA 20" X 18", COLOR "WHITE", CENTER HOLE SETTING & SOAP DISPENSER HOLE, REAR OVERFLOW, FOR CONCEALED ARM SUPPORT, FURNISH FLOOR MOUNTED SINGLE CARRIER WITH CONCEALED ARMS, LEVELING AND SECURING SCREWS, STRUCTURAL UPRIGHTS AND BLOCK BASES, SECURE BASE TO FLOOR FOR RIGID CONNECTION WITH 1/2" X 3-3/4" THREADED ZINC PLATED STEEL	LAVATORY	ZURN Z415J
--	----------	------------

- HEAVY DUTY WEDGE ANCHORS, COMPLETE WITH STAINLESS STEEL CLIP, WASHER AND THREADED NUT, CONFORMING TO FEDERAL SPEC. FF-S-323. PROVIDE CHROME PLATED ANGLE STOP TO WALL WITH CHROME PLATED 1/2" IPS X 3/8" OD FLEXIBLE SUPPLY AND LOOSE KEY OPERATOR, INTEGRAL PERFORATED CAST BRASS STRAINER WITH ELBOW AND 1-1/4" OFFSET TAILPIECE, CHROME PLATED 17 GAUGE CAST BRASS P-TRAP WITH CLEANOUT AND TUBE WASTE TO WALL. POLISHED CHROME PLATED BRASS FAUCET, 0.5 GPM, SECOND CYCLE SENSOR OPERATED, AC PLUG. LAVATORY P-TRAP AND ANGLE VALVE ASSEMBLIES SHALL BE INSULATED WITH FULLY MOLDED INSULATION KIT, AND LIGHT GRAY COLOR WITH 3_PIECE INTERLOCKING RAP ASSEMBLY AND 2_PIECE INTERLOCKING ANGLE VALVE ASSEMBLY. FASTENERS SHALL BE NYLON TYPE SUPPLIED WITH KIT. LAVATORY SHALL BE MOUNTED WITH A CLEARANCE OF AT LEAST 28" FROM FLOOR TO BOTTOM OF THE APRON, KNEE AND TOE CLEARANCES SHALL BE AS FOLLOWS: 27" CLEAR HEIGHT SHALL BE PROVIDED FROM FINISHED FLOOR TO A POINT ON UNDERSIDE OF BOWL 4" IN FROM FRONT APRON. TOE CLEARANCE SHALL BE A MINIMUM HEIGHT OF 9" UNDER P-TRAP AND SUPPLIES OR STOPS. SEE ARCHITECTURAL DRAWINGS FOR FINAL MOUNTING HEIGHT. UNDER SINK MOUNTING VALVE WITH SOLDERED CONNECTION, BRONZE BODY, LIMITS HOT WATER BETWEEN 80F & 120F, DOUBLE THROTTLING, INTEGRAL INLET FILTER WASHERS & CHECK VALVES, TAMPER RESISTANT LOCKING CAP, MEETS ASSE 1070 STANDARDS.
- | | |
|--------------------|---------------------------|
| LAVATORY | KOHLER SOHO K-2084-RLD |
| FAUCET | KOHLER K-13468-CP |
| SUPPLY W/STOP | ZURN Z800RLBK |
| P-TRAP | ZURN Z8700-PC |
| STRAINER/TAILPIECE | ZURN Z8746 |
| INSULATION KIT | ZURN Z9146-3-NT |
| CARRIER | ZURN Z-1231 |
| BASE ANCHORAGE | B-LINE ANCHORS AWA-50-375 |
| MIXING VALVE | WATTS MMV-US-M1 |
- L-2 INTEGRATED SINK (3 STATION)

INTEGRATED SINK SYSTEM BOWL SHALL BE DESIGNED TO CONTROL AIR AND WATER FLOW PREVENTING BACKSPASH AND UPDRAFTS. IT SHALL CONTAIN FAUCET, SOAP DISPENSER, AND HAND DRYER FOR EACH STATION WITH STAINLESS STEEL SUPPORT SYSTEM. ALL CONTROLS SHALL BE HANDSFREE. SINK SHALL BE 90" WIDE WITH THREE (3) STATIONS, 1-1/4" OFFSET TAILPIECE, CHROME PLATED 17 GAUGE CAST BRASS P-TRAP WITH CLEANOUT AND TUBE WASTE TO WALL. MOUNT PER ADA REQUIREMENTS, REFER TO ARCHITECTURAL DRAWINGS FOR MOUNTING HEIGHTS. SINK TOP SHALL BE STELLAR SNOW QUARTZ AND SINK SURROUND AND BASIN SHALL BE CORIAN GLACIER (GROUP A). COLOR TO BE VERIFIED AND APPROVED BY ARCHITECT. MOUNT PER MANUFACTURER'S INSTALLATION INSTRUCTIONS, COORDINATE TRASH BIN LOCATIONS QUANTITY WITH ARCHITECT. DECK MOUNTED FAUCET SHALL BE MID BODIED, 0.5 GPM, POLISHED CHROME, HARD WIRED WITH THERMOSTATIC MIXING VALVE AND INFRARED SENSOR. POLISHED CHROME SOAP DISPENSER SHALL BE HARD WIRED, ONE PIECE CONSTRUCTION, DECK MOUNTED, INFRARED SENSOR. HAND DRYER SHALL BE POLISHED CHROME, HARD WIRED, INFRARED SENSOR, DECK MOUNTED. DRYER SHALL BE 4.5 AMPS AND SHALL HAVE NO HEAT.

SINK	D13 INTEGRATED SINK SYSTEM
FAUCET	STERN CONDOR 1010
SOAP DISPENSER	STERN SDE
HAND DRYER	EXCEL XLERATOR
SUPPLY W/STOP	ZURN Z800RLBK-PC
P-TRAP	ZURN Z8700-PC
 - L-3 INTEGRATED SINK (1 STATION)

INTEGRATED SINK SYSTEM BOWL SHALL BE DESIGNED TO CONTROL AIR AND WATER FLOW PREVENTING BACKSPASH AND UPDRAFTS. IT SHALL CONTAIN FAUCET, SOAP DISPENSER, AND HAND DRYER FOR EACH STATION. ALL CONTROLS SHALL BE HANDSFREE. SINK SHALL BE 90" WIDE WITH THREE (3) STATIONS, 1-1/4" OFFSET TAILPIECE, CHROME PLATED 17 GAUGE CAST BRASS P-TRAP WITH CLEANOUT AND TUBE WASTE TO WALL. MOUNT PER ADA REQUIREMENTS, REFER TO ARCHITECTURAL DRAWINGS FOR MOUNTING HEIGHTS. SINK TOP SHALL BE STELLAR SNOW QUARTZ AND SINK SURROUND AND BASIN SHALL BE CORIAN GLACIER (GROUP A). COLOR TO BE VERIFIED AND APPROVED BY ARCHITECT. MOUNT PER MANUFACTURER'S INSTALLATION INSTRUCTIONS, COORDINATE TRASH BIN LOCATIONS QUANTITIES WITH ARCHITECT. DECK MOUNTED FAUCET SHALL BE MID BODIED, 0.5 GPM, POLISHED CHROME, HARD WIRED WITH THERMOSTATIC MIXING VALVE AND INFRARED SENSOR. POLISHED CHROME SOAP DISPENSER SHALL BE HARD WIRED, ONE PIECE CONSTRUCTION, DECK MOUNTED, INFRARED SENSOR. HAND DRYER SHALL BE POLISHED CHROME, HARD WIRED, INFRARED SENSOR, DECK MOUNTED. DRYER SHALL BE 4.5 AMPS AND HAVE NO HEAT.

SINK	D13 INTEGRATED SINK SYSTEM
FAUCET	STERN CONDOR 1010
SOAP DISPENSER	STERN SDE
HAND DRYER	EXCEL XLERATOR
SUPPLY W/STOP	ZURN Z800RLBK-PC
P-TRAP	ZURN Z8700-PC
 - EW-1 ELECTRIC WATER COOLER (BARRIER-FREE):

DUAL LEVEL STAINLESS STEEL WALL MOUNT, PUSH BUTTON CONTROL, IN-THE-WALL FRAME & PLATE, REFRIGERATION SYSTEM WITH R-134A REFRIGERANT, TUBE-TANK TYPE COOLING UNIT, FAN COOLED CONDENSER, HERMETICALLY SEALED COMPRESSOR, TEMPERATURE CONTROL, AND A CHILLING CAPACITY OF 8GPH OF 50 °F WATER, NSF 42 & 53 CERTIFIED FILTER, STAINLESS STEEL GRILL, FLEX GUARD SAFETY BUBBLER WITH PROTECTIVE STAINLESS STEEL BACK PLATE, FURNISH FLOOR MOUNTED CARRIER WITH BEARING PLATE, HANGER PLATE, ADJUSTABLE SUPPORTING RODS, STRUCTURAL UPRIGHTS AND BLOCK BASES, MOUNT TO SATISFY ADA REQUIREMENTS, VERIFY FINAL LOCATION, MOUNTING HEIGHT AND FINISH WITH ARCHITECTURAL DRAWINGS. PROVIDE FREEZE RESISTANT VALVE ASSEMBLY IN RECESSED WALL BOX COMPLETE WITH WATER SUPPLY VALVE AND WASTE PIPING. PROVIDE CHROME PLATED ANGLE STOP TO WALL WITH CHROME PLATED 1/2" IPS X 3/8" OD FLEXIBLE SUPPLY AND LOOSE KEY OPERATOR, CHROME PLATED 17 GAUGE CAST BRASS P-TRAP WITH CLEANOUT AND TUBE WASTE TO WALL.

ELECTRIC WATER COOLER	EIKAY LRPM28K
SUPPLY W/STOP	ZURN Z800ZRLBK
P-TRAP	ZURN Z8700-PC
 - EW-2 ELECTRIC WATER COOLER - ALTERNATE (BARRIER-FREE):

DUAL LEVEL WITH BOTTLE FILL STATION, STAINLESS STEEL WALL MOUNT, PUSH BUTTON CONTROL, IN-THE-WALL FRAME & PLATE, REFRIGERATION SYSTEM WITH R-134A REFRIGERANT, TUBE-TANK TYPE COOLING UNIT, FAN COOLED CONDENSER, HERMETICALLY SEALED COMPRESSOR, TEMPERATURE CONTROL, AND A CHILLING CAPACITY OF 8GPH OF 50 °F WATER, NSF 42 & 53 CERTIFIED FILTER, STAINLESS STEEL GRILL, FLEX GUARD SAFETY BUBBLER WITH PROTECTIVE STAINLESS STEEL BACK PLATE, BOTTLE FILL STATION IS SENSOR-ACTIVATED, FILTER SCREEN, GREEN TRIGGER, AND DRAIN/FURNISH FLOOR MOUNTED CARRIER WITH BEARING PLATE, HANGER PLATE, ADJUSTABLE SUPPORTING RODS, STRUCTURAL UPRIGHTS AND BLOCK BASES, MOUNT TO SATISFY ADA REQUIREMENTS, VERIFY FINAL LOCATION, MOUNTING HEIGHT AND FINISH WITH ARCHITECTURAL DRAWINGS. PROVIDE FREEZE RESISTANT VALVE ASSEMBLY IN RECESSED WALL BOX COMPLETE WITH WATER SUPPLY VALVE AND WASTE PIPING. PROVIDE CHROME PLATED ANGLE STOP TO WALL WITH CHROME PLATED 1/2" IPS X 3/8" OD FLEXIBLE SUPPLY AND LOOSE KEY OPERATOR, CHROME PLATED 17 GAUGE CAST BRASS P-TRAP WITH CLEANOUT AND TUBE WASTE TO WALL.

ELECTRIC WATER COOLER	EIKAY LZWS-LRPM28K
SUPPLY W/STOP	ZURN Z800ZRLBK
P-TRAP	ZURN Z8700-PC
 - LD-1 LINEAR DRAIN (5-1/2 x 13):

DURA-COATED CAST IRON BODY WITH BOTTOM OUTLET, COMBINATION INVERTIBLE MEMBRANE CLAMP AND ADJUSTABLE COLLAR WITH SEEPAGE SLOTS AND "TYPE P" POLISHED, NICKEL BRONZE RECTANGULAR, LIGHT-DUTY, HEEL-PROOF STRAINER, TRAP PRIMER CONNECTION.

LINEAR DRAIN	ZURN Z415J
--------------	------------



MEMBERSHIP OF SERVICES
ALL REPORTS, PLANS, SPECIFICATIONS, COMPUTER FILES, FIELD DATA, NOTES AND OTHER DOCUMENTS ARE THE PROPERTY OF LAG GROUP, INC. AND WILL REMAIN THE PROPERTY OF LAG GROUP, INC. AFTER THE COMPLETION OF THE CONTRACT. THE CONTRACTOR SHALL BE RESPONSIBLE FOR THE PROTECTION OF ALL DOCUMENTS, STATUTORY AND OTHER RESERVED RIGHTS, INCLUDING THE COPYRIGHT THEREIN.

PURSUANT TO FLORIDA STATUTES, SECTION 690.005, AN INDIVIDUAL EMPLOYEE OR AGENT MAY NOT BE HELD INDIVIDUALLY LIABLE FOR NEGLIGENCE.

BID DOCUMENTS

**EMERALD COAST CONVENTION CENTER
RESTROOM RENOVATIONS & MEETING ROOM
COUNTERS**
TASK ORDER NO. 5 - C-18-2638-TDD
 1250 MIRACLE STRIP PKWY SE
 FORT WALTON BEACH, FL 32548

REVISIONS:

No.	Description	Date

PLUMBING SPECIFICATIONS

Project number	17057.5
Dated	JANUARY 2019
PMC	DNW
PM	KAJ

P002

Scale NONE

Watford Engineering, Inc.
 Mechanical Consulting
 4471 Clinton Street
 Marianna, FL 32448
 Florida CA Number: 27802
 Project Number: 2018-021

T: 850-526-3447
 F: 850-526-3448
 David N. Watford, PE
 FL License Number: #8008



OWNERSHIP OF SERVICE:
 ALL REPORTS, PLANS, SPECIFICATIONS, COMPUTER FILES,
 FIELD DATA, NOTES AND OTHER DOCUMENTS AND
 INSTRUMENTS PREPARED BY THE CONSULTANT AS AN
 INSTRUMENT OF SERVICE SHALL REMAIN THE PROPERTY OF
 THE CONSULTANT. THE CONSULTANT SHALL RETAIN ALL
 COMMON LAW, STATUTORY AND OTHER RESERVED RIGHTS,
 INCLUDING THE COPYRIGHT THEREIN.

PURSUANT TO FLORIDA STATUTES, SECTION 690.005, AN
 INDIVIDUAL EMPLOYEE OR AGENT MAY NOT BE HELD
 INDIVIDUALLY LIABLE FOR NEGLIGENCE.

BID DOCUMENTS

EMERALD COAST CONVENTION CENTER
**RESTROOM RENOVATIONS & MEETING ROOM
 COUNTERS**
 TASK ORDER NO. 5 - C-18-2638-TDD
 1250 MIRACLE STRIP PKWY SE
 FORT WALTON BEACH, FL 32548

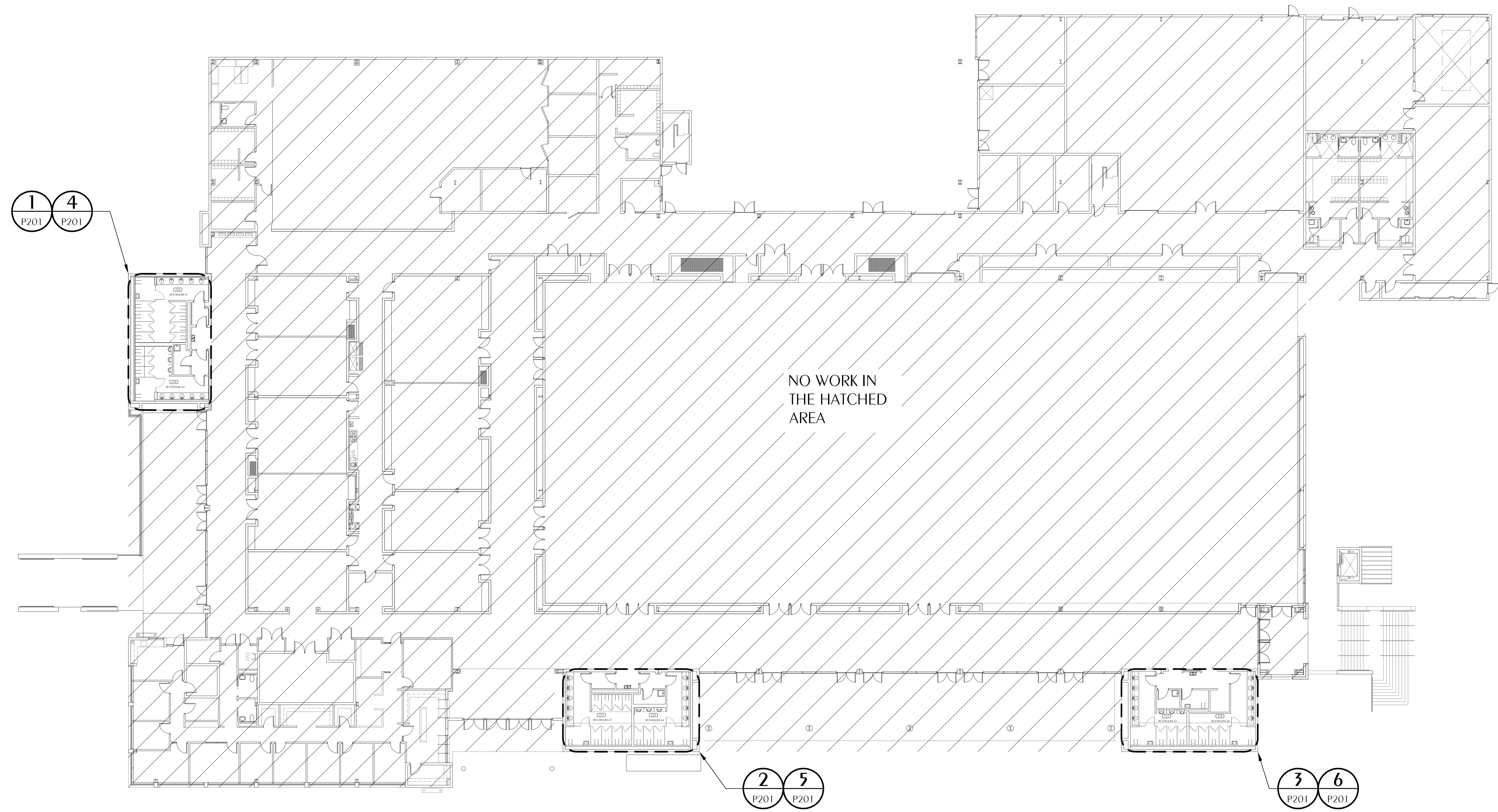

1 PLUMBING OVERALL PLAN
 SCALE: 1/16" = 1'-0"

REVISIONS:

No.	Description	Date

PLUMBING OVERALL
 PLAN

Project number	17057.5
Dated	JANUARY 2019
PIC	DNW
PM	KAJ

P101

Scale 1/16"=1'-0"

Watford Engineering, Inc.
 Mechanical Consulting
 4471 Clinton Street
 Marianna, FL 32446
 Florida CA Number: 27825
 Project Number: 2018-021

T: 850-526-3447
 F: 850-526-3448
 David N. Watford, PE
 FL License Number: 38208



OWNERSHIP OF SERVICE
 ALL REPORTS, PLANS, SPECIFICATIONS, COMPUTER FILES,
 FIELD DATA, NOTES AND OTHER DOCUMENTS AND
 INSTRUMENTS PREPARED BY THE CONSULTANT AS AN
 INSTRUMENT OF SERVICE SHALL REMAIN THE PROPERTY OF
 THE CONSULTANT. THE CONSULTANT SHALL RETAIN ALL
 COMMON LAW, STATUTORY AND OTHER RESERVED RIGHTS,
 INCLUDING THE COPYRIGHT THEREIN.

PURSUANT TO FLORIDA STATUTES, SECTION 98.003(4), AN
 INDIVIDUAL, EMPLOYEE OR AGENT MAY NOT BE HELD
 INDIVIDUALLY LIABLE FOR NEGLIGENCE.

BID DOCUMENTS

EMERALD COAST CONVENTION CENTER
 RESTROOM RENOVATIONS & MEETING ROOM
 COUNTERS
 TASK ORDER NO. 5 - C18-2638-TDD
 1250 MIRACLE STRIP PKWY SE
 FORT WALTON BEACH, FL 32548

SHEET NOTES

- 1 REMOVE EXISTING WATER CLOSET. PREPARE TO REPLACE WITH NEW. TYPICAL.
- 2 REMOVE EXISTING LAVATORY. PREPARE TO REPLACE WITH NEW. TYPICAL.
- 3 REMOVE EXISTING URINAL. PREPARE TO REPLACE WITH NEW. TYPICAL.
- 4 REMOVE EXISTING FLOOR DRAIN. SAWCUT SLAB TO PREPARE FOR INSTALLATION OF NEW LINEAR DRAIN. TYPICAL.
- 5 CONNECT NEW FIXTURE TO EXISTING DOMESTIC WATER AND SANITARY PIPING IN THE AREA. TYPICAL.
- 6 CONNECT NEW LAVATORY TO EXISTING DOMESTIC WATER AND SANITARY PIPING IN THE AREA. LAVATORY SHALL HAVE THREE FAUCETS AND TWO DRAINS.
- 7 PROVIDE NEW WALL HYDRANT. CONNECT TO EXISTING 3/4" CW IN AREA.
- 8 REMOVE EXISTING ELECTRIC WATER COOLER. PREPARE TO REPLACE WITH NEW.
- 9 CONNECT NEW LAVATORY TO EXISTING DOMESTIC WATER AND SANITARY PIPING IN THE AREA. LAVATORY HAS ONE FAUCET AND ONE DRAIN.
- 10 PROVIDE NEW CLEANOUT COVER IN FINISHED WALL AT EXISTING CLEANOUT LOCATION.
- 11 SEAL PIPE AROUND NEW FIRE RATED WALL. REFER TO M301 AND M302.
- 12 INSULATE EXISTING 4" HORIZONTAL STORMWATER PIPING WITH 1/2" THICK FLEXIBLE UNICELLULAR PIPE INSULATION. INSULATION SHALL BE ASTM C534, TYPE I.
- 13 REUSE EXISTING FIXTURE CARRIER.

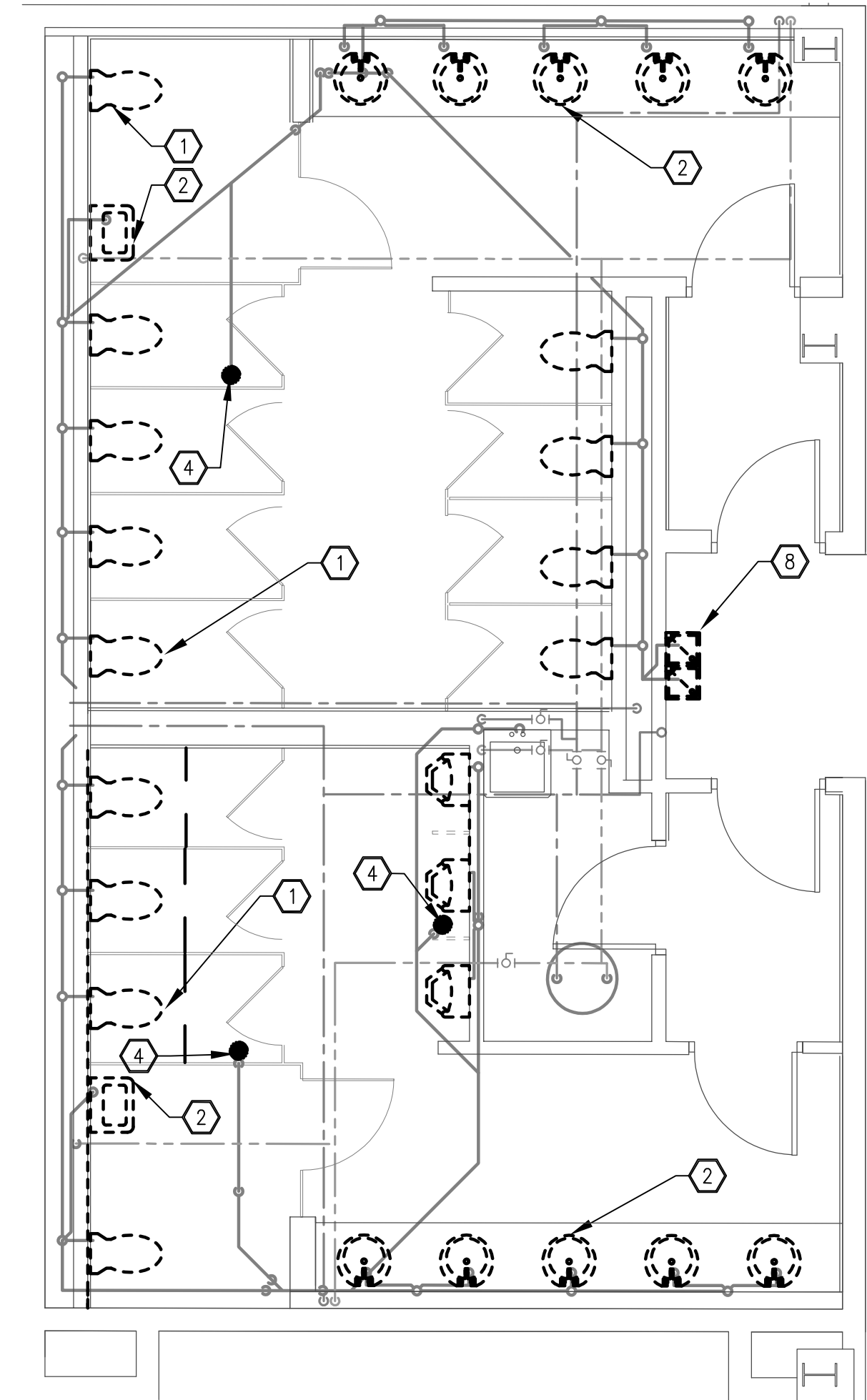

1 RESTROOM 1 & 2 PLUMBING DEMOLITION PLAN
 P201 SCALE: 1/4" = 1'-0"

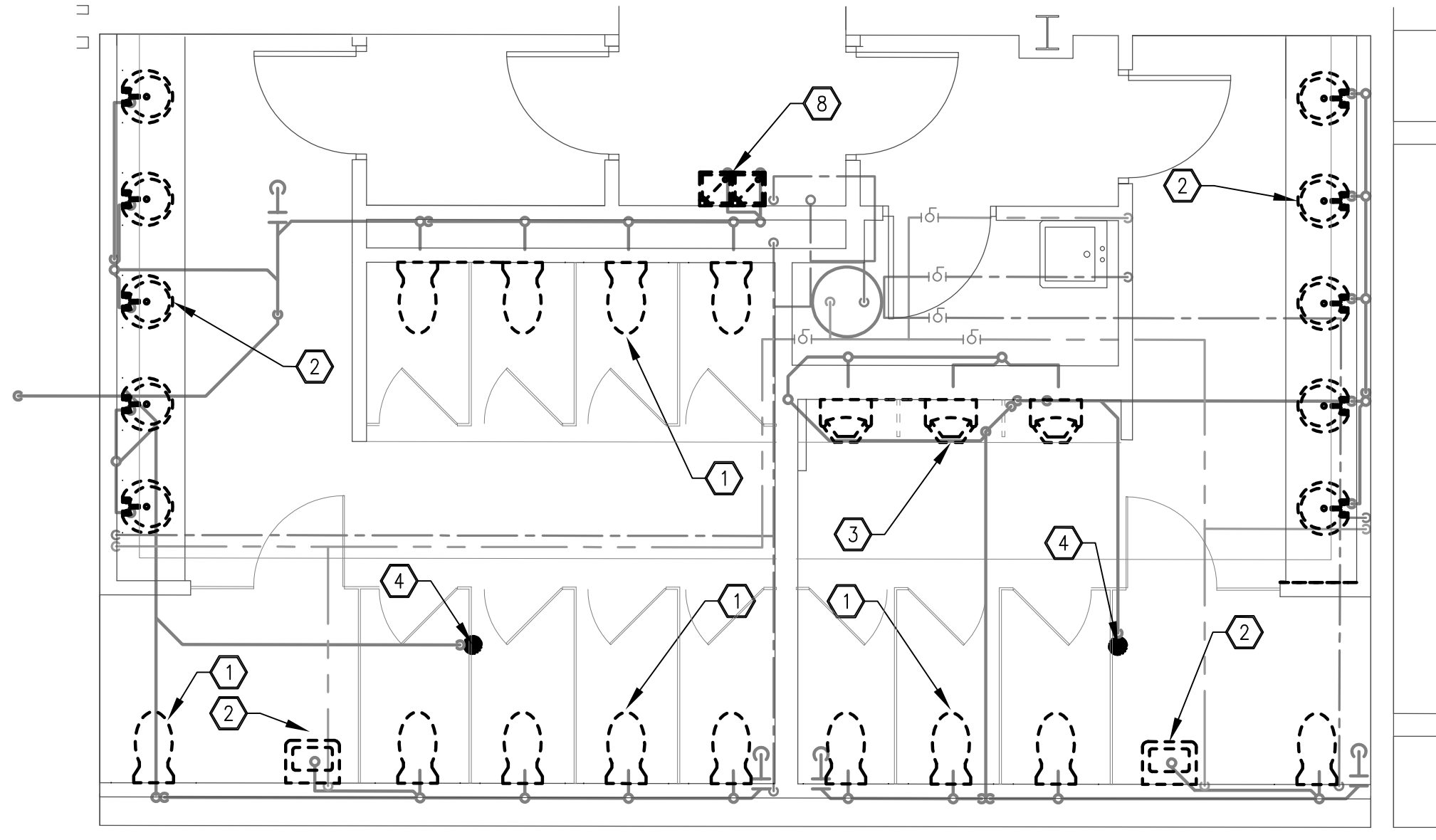

2 RESTROOM 3 & 4 PLUMBING DEMOLITION PLAN
 P201 SCALE: 1/4" = 1'-0"

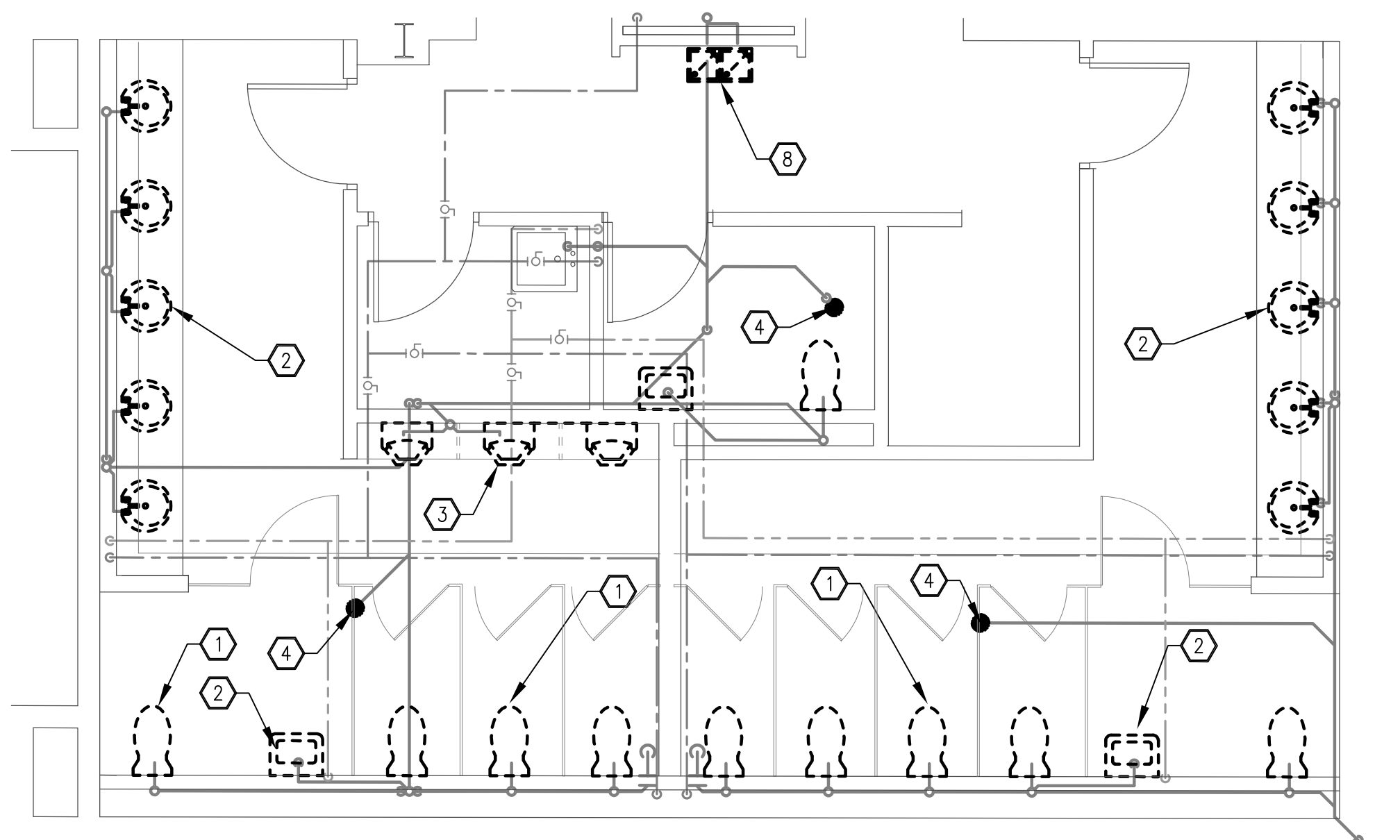

3 RESTROOM 5 & 6 PLUMBING DEMOLITION PLAN
 P201 SCALE: 1/4" = 1'-0"

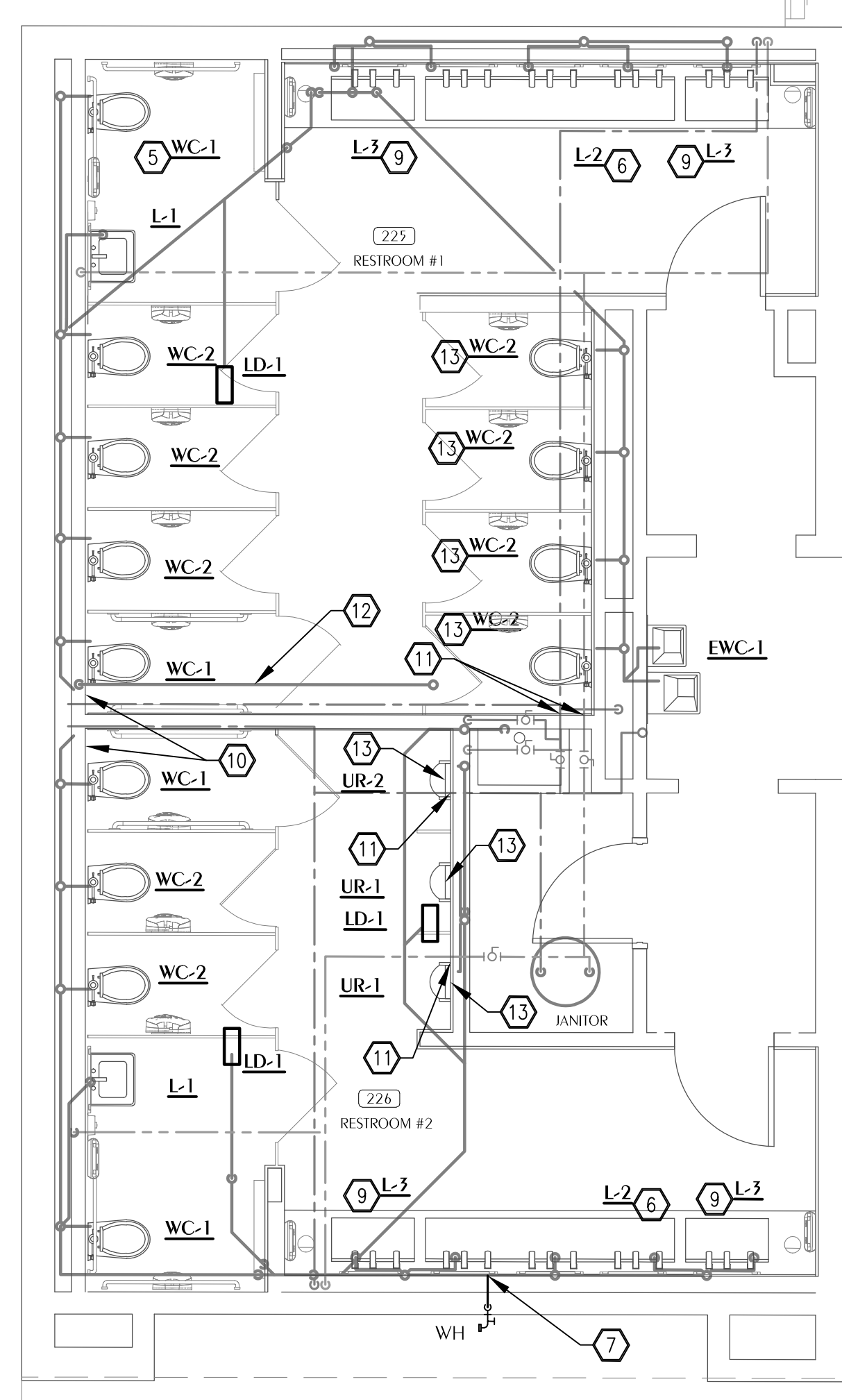

4 RESTROOM 1 & 2 PLUMBING NEW WORK PLAN
 P201 SCALE: 1/4" = 1'-0"

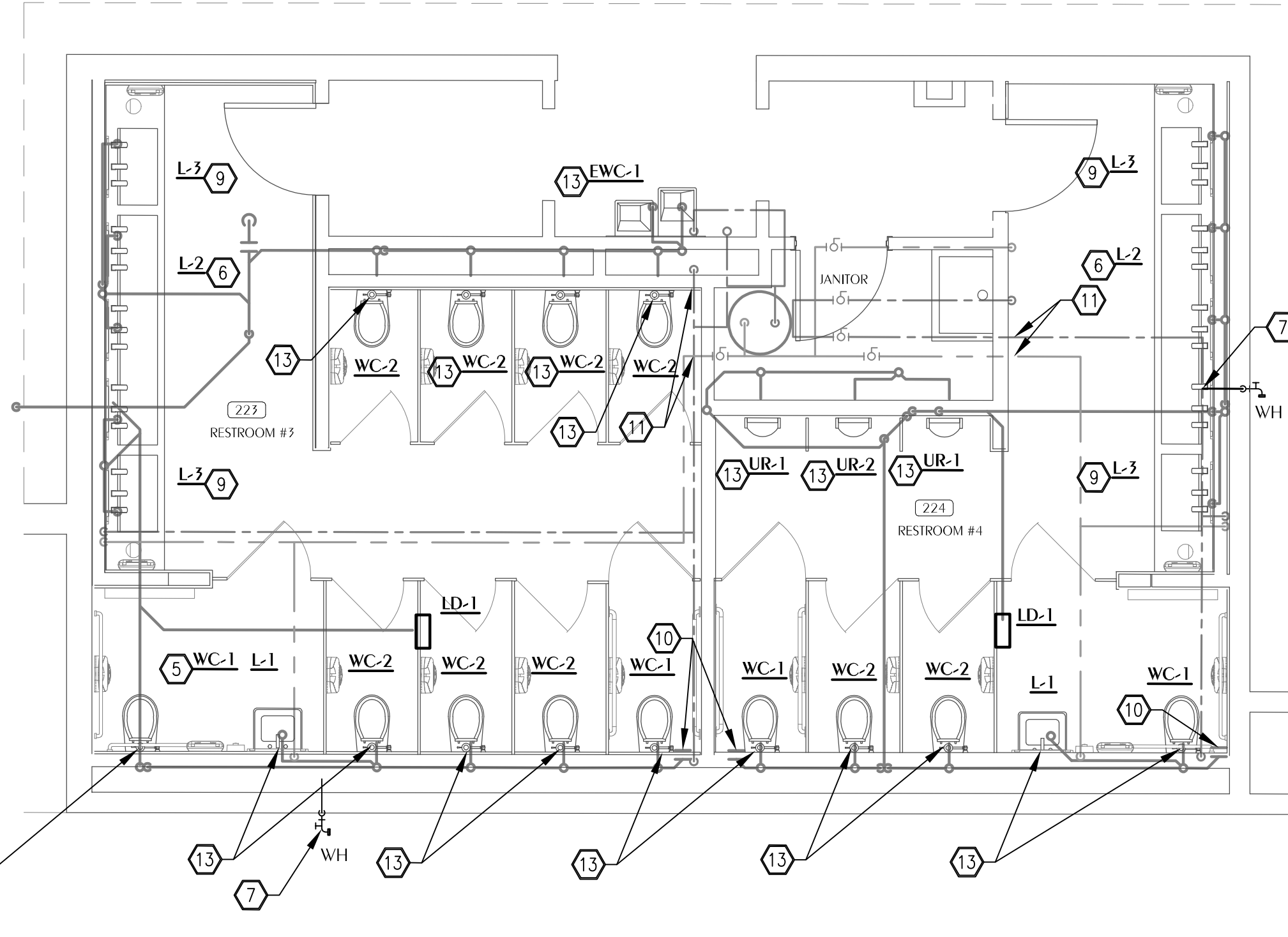

5 RESTROOM 3 & 4 PLUMBING NEW WORK PLAN
 P201 SCALE: 1/4" = 1'-0"

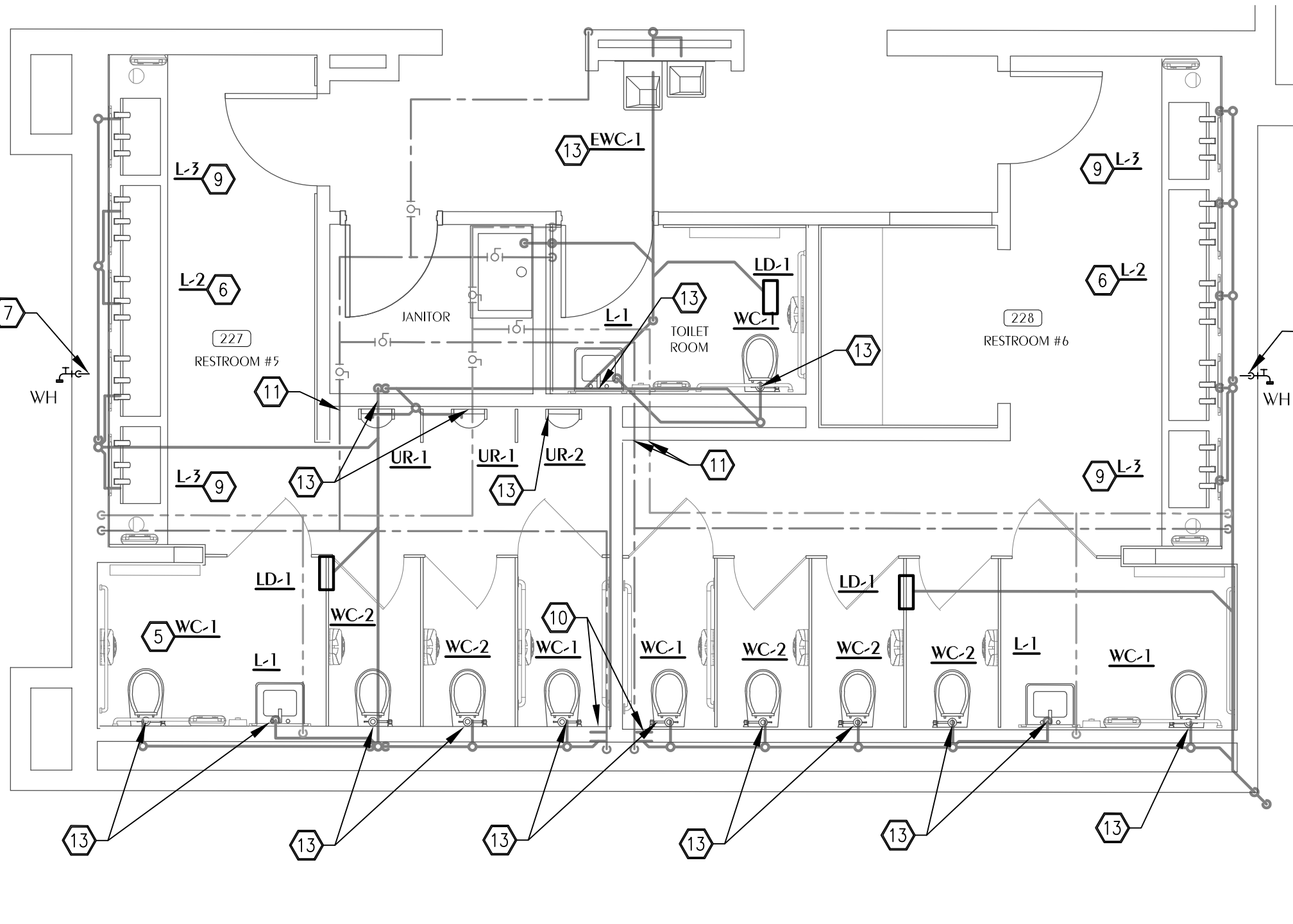

6 RESTROOM 5 & 6 PLUMBING NEW WORK PLAN
 P201 SCALE: 1/4" = 1'-0"

REVISIONS:

No.	Description	Date

PLUMBING ENLARGED PLANS

Project number	17057.5
Dated	JANUARY 2019
PKC	DNW
PM	KAJ

P201

Scale 1/4"=1'-0"

Watford Engineering, Inc.
 Mechanical Consulting
 4471 Clinton Street
 Marianna, FL 32446
 Florida CA Number: 27855
 Project Number: 2018-021
 T: 850-926-3447
 F: 850-225-3448
 David N. Watford, PE
 FL License Number: 58208

LEGEND

- FW FIRE WATER SUPPLY
- PW POTABLE WATER SUPPLY
- SPRINKLER HEAD

GENERAL NOTES

1. IT IS NOTED THAT SOME AREAS WILL BE REQUIRED TO BE PROTECTED AS ORDINARY HAZARD (MECHANICAL ROOMS, ETC.) THESE AREAS HAVE BEEN IDENTIFIED BY A DIFFERENT HATCHING PATTERN THEN THE LIGHT HAZARD AREAS ON THE PLANS.
2. MAINTAIN THE INTEGRITY OF ALL FIRE RATED ASSEMBLIES AND ACOUSTICAL ASSEMBLIES.
3. CONTRACTOR SHALL COORDINATE SYSTEM DESIGN WITH ALL OTHER TRADES.
4. ALL PIPING SHALL OBSERVE PROPER PITCH. PROVIDE DRAINS FOR LOW POINTS.
5. PIPE HANGERS SHALL BE INSTALLED AS REQUIRED BY NFPA 13 FOR SUPPORTING SPRINKLER PIPING. NO OTHER PIPING OR DEVICES SHALL BE ATTACHED TO THE SPRINKLER HANGER SYSTEM UNLESS THE HANGER HAS BEEN DESIGNED TO CARRY THE ADDITIONAL LOAD.
6. THIS CONTRACT DOES NOT INCLUDE ANY MATERIAL OR DEVICE TO IMPROVE THE STRUCTURAL STRENGTH OF THE BUILDING TO ENABLE IT TO CARRY THE LOAD OF THE FIRE PROTECTION SYSTEM.
7. ALL ABOVE GROUND WET SPRINKLER PIPE THAT IS THREADED SHALL BE SCHEDULE 40 BLACK WITH BLACK CAST/MALEABLE IRON FITTINGS WITH JOINTS PER NFPA 13. TEFLON TAPE SHALL BE ADDED TO ALL MALE THREADS OF PIPE AS A JOINING COMPOUND. CPVC PIPING IS NOT ACCEPTABLE.
8. ALL ABOVE GROUND WET SYSTEM SPRINKLER PIPE THAT IS WELDED OR ROLL-GROOVED SHALL BE SCHEDULE 10 BLACK WITH BLACK CAST/MALEABLE IRON FITTINGS WITH JOINTS PER NFPA 13. CPVC PIPING IS NOT ACCEPTABLE.
9. INSTALL SPRINKLER HEADS CENTER OF TILE IN ACOUSTICAL CEILING. HEAD LOCATIONS SHALL BE GUIDED BY ARCHITECTURAL ELEMENTS FOR OTHER CEILING TYPES.
10. ALL WORK SHALL COMPLY WITH SIXTH EDITION (2017) OF FLORIDA BUILDING CODE, NFPA 13-2019, AND SIXTH EDITION (2017) FLORIDA FIRE PREVENTION CODE.
11. REFER TO M301 AND M302 FOR PIPE PENETRATIONS OF NEW FIRE WALLS.

WATER BASED SPRINKLER SYSTEM REQUIREMENTS

1. THE PROJECT IS A MODIFICATION OF EXISTING FIRE SPRINKLER SYSTEM. NO CHANGE IN POINT OF SERVICE OF WATER SUPPLY WILL OCCUR.
2. THE BUILDING SHALL BE FULLY SPRINKLED IN ACCORDANCE WITH THE MOST RECENT EDITION OF NFPA 13 AND LOCAL CODES.
3. THERE IS NO CHANGE TO HAZARD CLASSIFICATION OF THE AFFECTED ROOMS.
4. THE MODIFICATION TO EXISTING SHALL BE HYDRAULICALLY CALCULATED IN ACCORDANCE WITH NFPA 13.
5. THE POINT OF SERVICE CONNECTION IS EXISTING, AND WILL NOT BE MODIFIED WITH THIS PROJECT.
6. NO NEW FLOW TEST IS REQUIRED FOR THIS MODIFICATION TO EXISTING SYSTEM.
7. THE EXISTING RISER WILL NOT BE MODIFIED WITH THIS PROJECT.
8. MICROBIAL INDUCED CORROSION IS NOT ANTICIPATED IN THIS PROJECT.
9. BACKFLOW PREVENTER IS EXISTING AND WILL NOT BE MODIFIED WITH THIS PROJECT.
10. REFER TO GENERAL NOTES FOR QUALITY AND PERFORMANCE SPECIFICATIONS OF ALL FIRE PROTECTION COMPONENTS.
11. NO FIRE PUMP IS REQUIRED.
12. NO ON SITE FIREWATER STORAGE TANK IS REQUIRED.

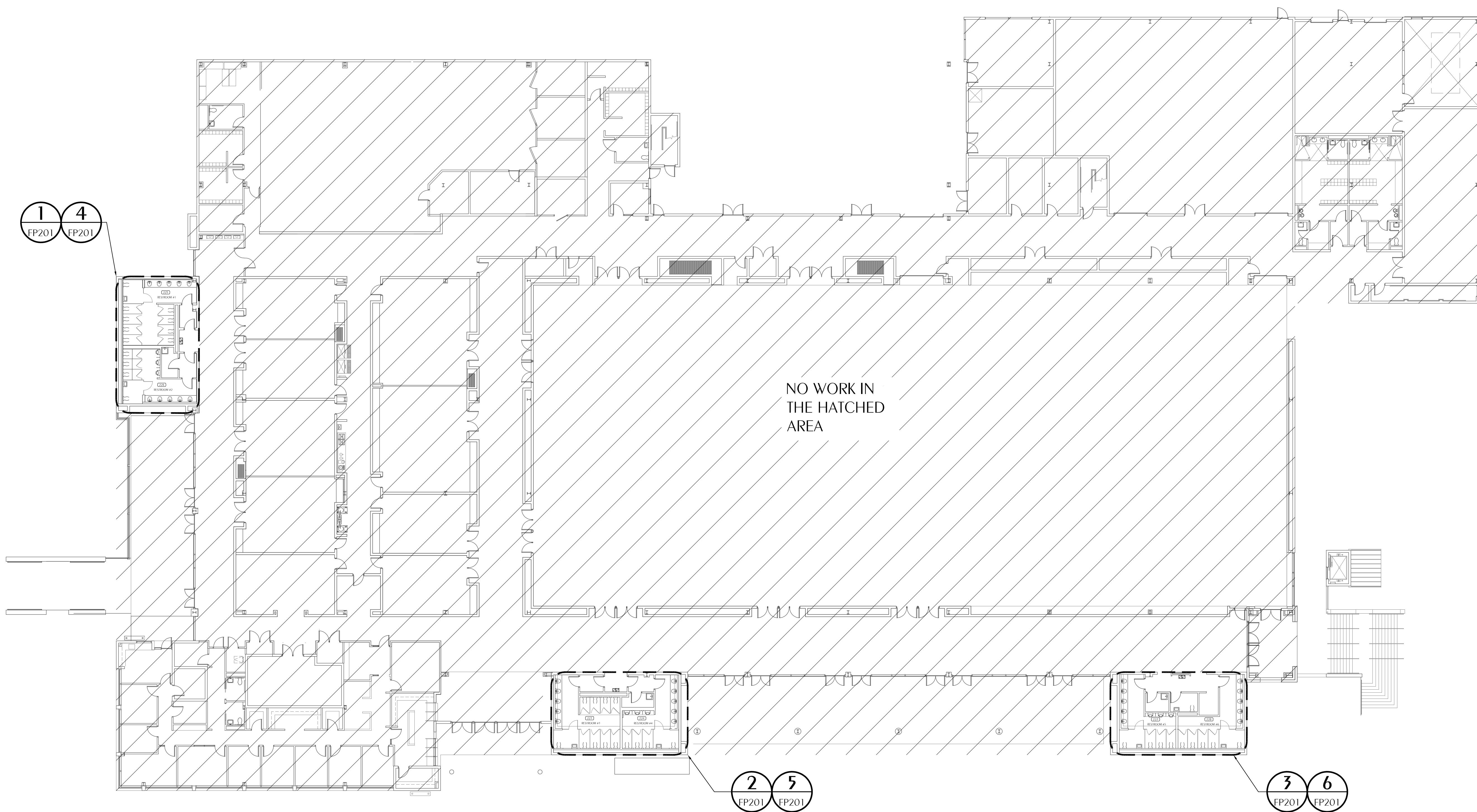

1 FIRE PROTECTION OVERALL PLAN
SCALE: 1/16" = 1'-0"



OWNERSHIP OF SERVICE: ALL REPORTS, PLANS, SPECIFICATIONS, COMPUTER FILES, FIELD DATA, NOTES AND OTHER DOCUMENTS AND INSTRUMENTS PREPARED BY THE CONSULTANT AS AN INSTRUMENT OF SERVICE SHALL REMAIN THE PROPERTY OF THE CONSULTANT. THE CONSULTANT SHALL RETAIN ALL COMMON LAW, STATUTORY AND OTHER RESERVED RIGHTS, INCLUDING THE COPYRIGHT THEREIN.

PURSUANT TO FLORIDA STATUTES, SECTION 69.005, AN INDIVIDUAL EMPLOYEE OR AGENT MAY NOT BE HELD INDIVIDUALLY LIABLE FOR NEGLIGENCE.

BID DOCUMENTS

**EMERALD COAST CONVENTION CENTER
RESTROOM RENOVATIONS & MEETING ROOM
COUNTERS**
TASK ORDER NO. 5 - C-18-2638-TDD
1250 MIRACLE STRIP PKWY SE
FORT WALTON BEACH, FL 32548

REVISIONS:

No.	Description	Date

FIRE PROTECTION OVERALL PLAN

Project number	17057.5
Dated	JANUARY 2019
PIC	DNW
PM	KAJ

FP101

Scale 1/16"=1'-0"

Watford Engineering, Inc.
Mechanical Consulting
4471 Clinton Street
Maitland, FL 32751
Florida CA Number: 27825
Project Number: 2018-021

T: 850-526-3447
F: 850-526-3448
David N. Watford, PE
FL License Number: 88208



OWNERSHIP OF SERVICE:
ALL REPORTS, PLANS, SPECIFICATIONS, COMPUTER FILES,
FIELD DATA, NOTES AND OTHER DOCUMENTS AND
INSTRUMENTS PREPARED BY THE CONSULTANT AS AN
INSTRUMENT OF SERVICE SHALL REMAIN THE PROPERTY OF
THE CONSULTANT. THE CONSULTANT SHALL RETAIN ALL
COMMON LAW, STATUTORY AND OTHER RESERVED RIGHTS,
INCLUDING THE COPYRIGHT THEREIN.

PURSUANT TO FLORIDA STATUTES, SECTION 690.005, AN
INDIVIDUAL EMPLOYEE OR AGENT MAY NOT BE HELD
INDIVIDUALLY LIABLE FOR NEGLIGENCE.

BID DOCUMENTS

EMERALD COAST CONVENTION CENTER
RESTROOM RENOVATIONS & MEETING ROOM
COUNTERS
TASK ORDER NO. 5 - C-18-2638-TDD
1250 MIRACLE STRIP PKWY SE
FORT WALTON BEACH, FL 32548

SHEET NOTES

- ① REMOVE EXISTING FIRE SPRINKLER HEAD. PREPARE FOR INSTALLATION OF NEW SPRINKLER HEAD. TYPICAL.
- ② PROVIDE NEW SPRINKLER HEAD. HEAD SHALL BE RECESSED PENDANT, CHROME, WITH A K-FACTOR OF 3.6 TO MATCH EXISTING SPRINKLER HEADS. CONNECT TO EXISTING FIRE SPRINKLER PIPING. TYPICAL.
- ③ SEAL PIPE PENETRATION OF NEW FIRE WALL PER 2/M302.

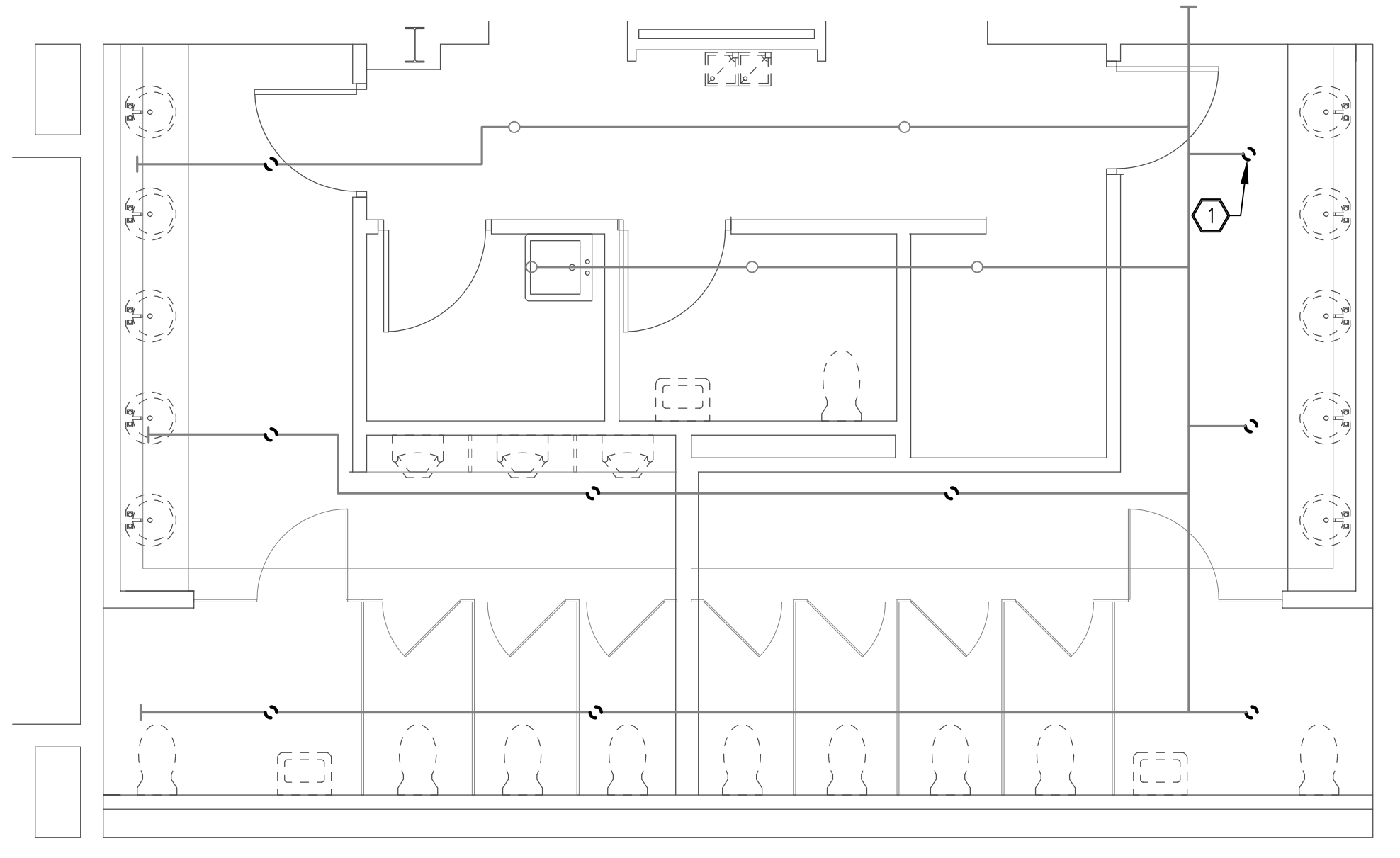
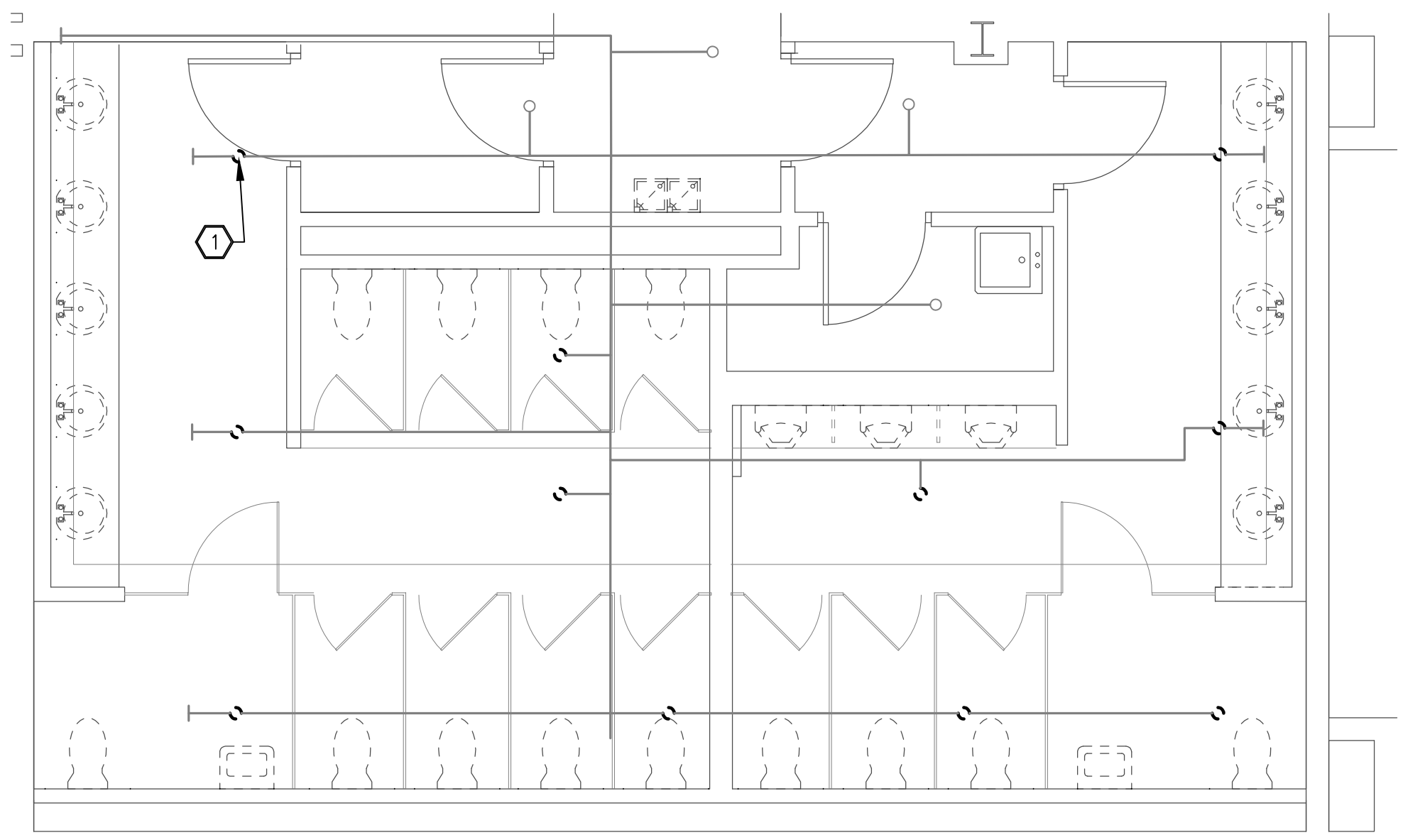
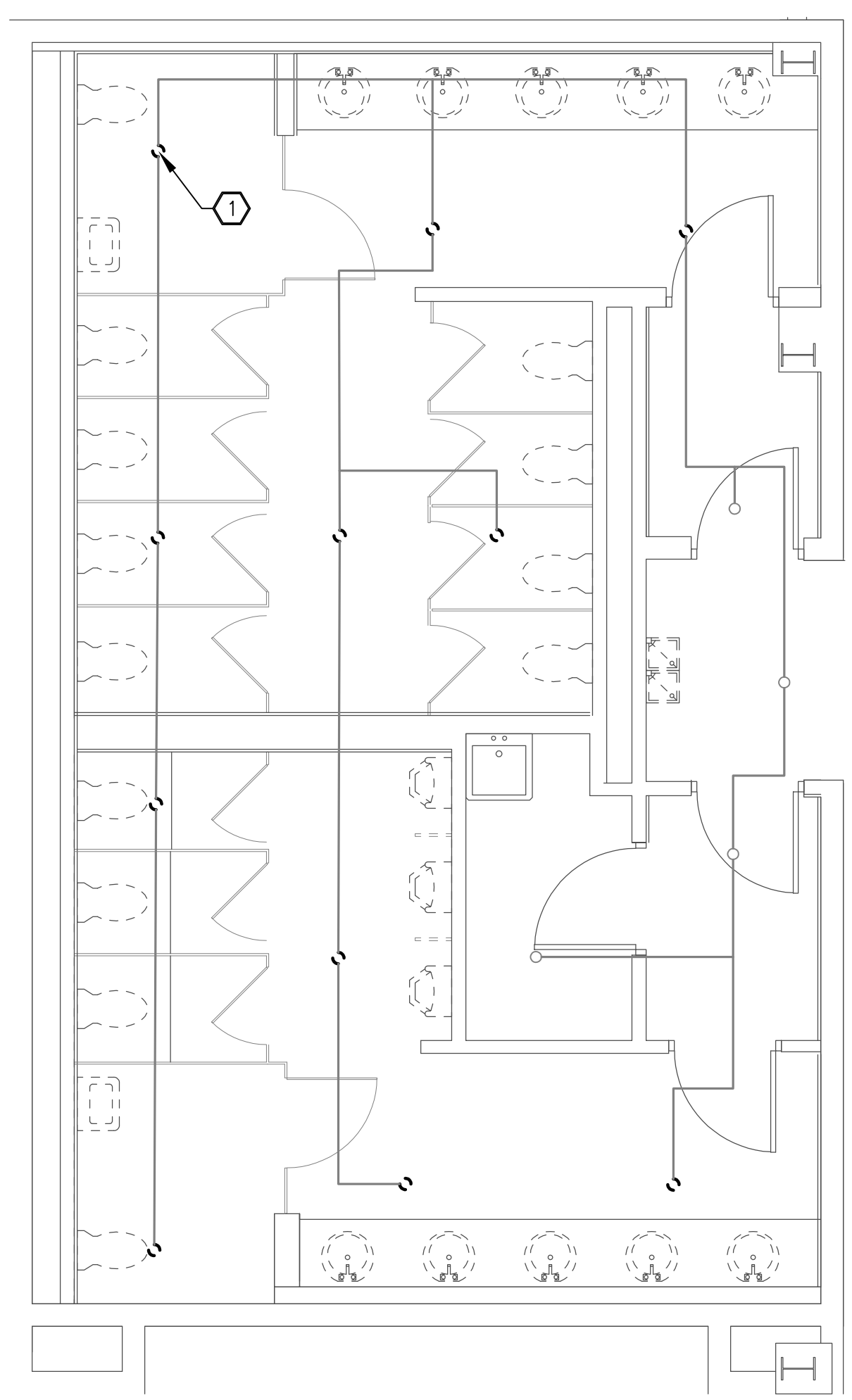

1 RESTROOM 1 & 2 FIRE PROTECTION DEMOLITION PLAN
FP201 SCALE: 1/4" = 1'-0"

2 RESTROOM 3 & 4 FIRE PROTECTION DEMOLITION PLAN
FP201 SCALE: 1/4" = 1'-0"

3 RESTROOM 5 & 6 FIRE PROTECTION DEMOLITION PLAN
FP201 SCALE: 1/4" = 1'-0"

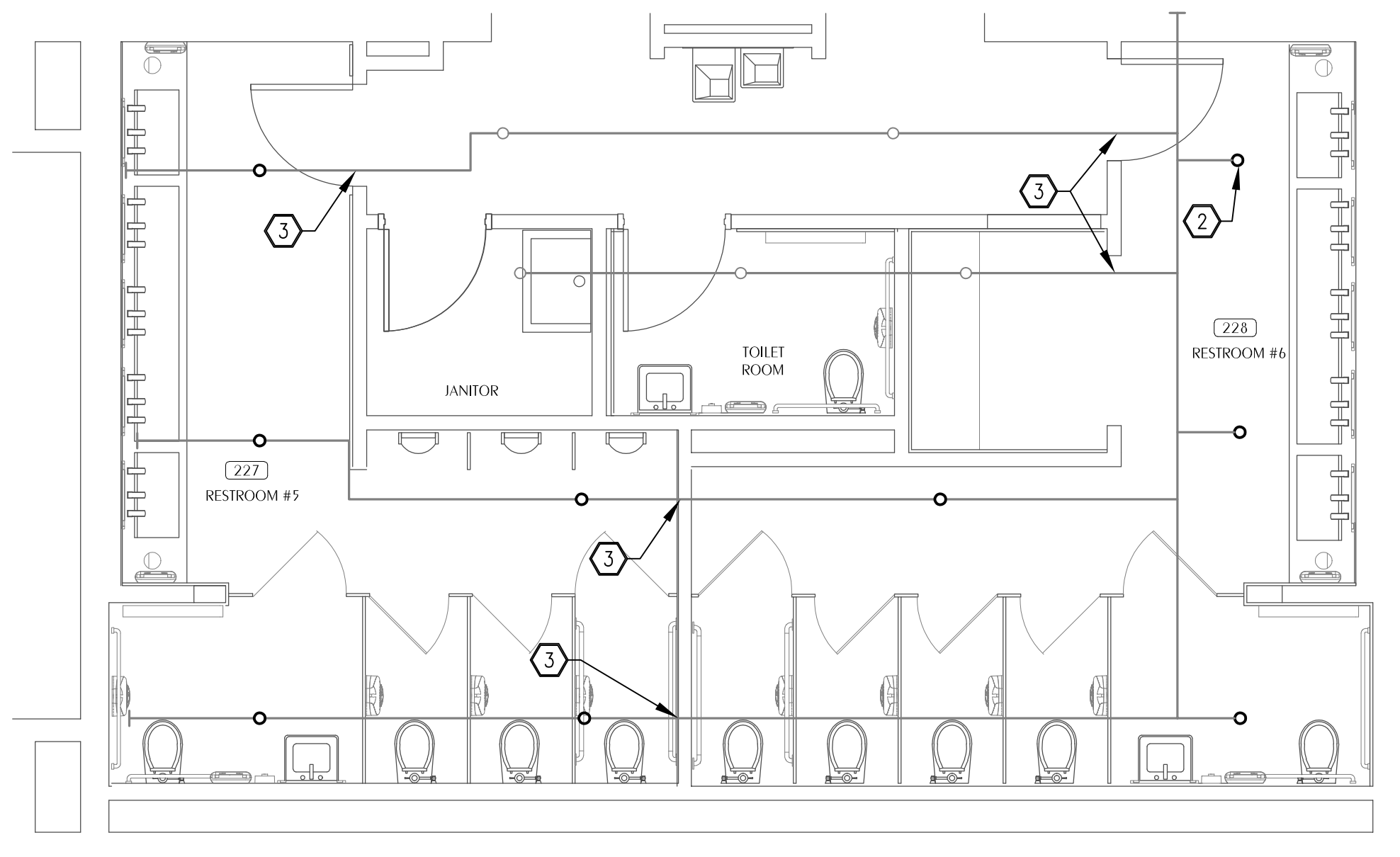
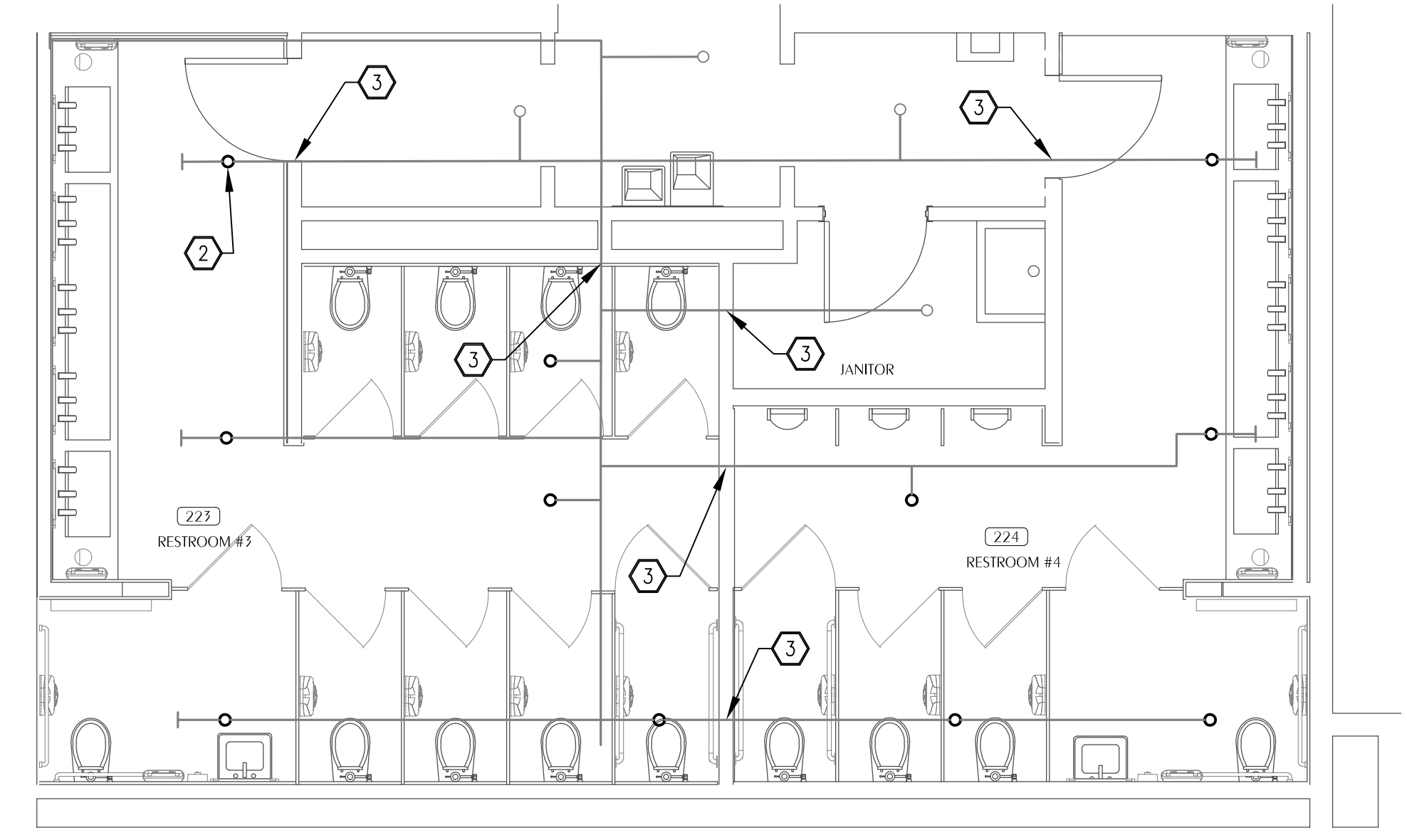
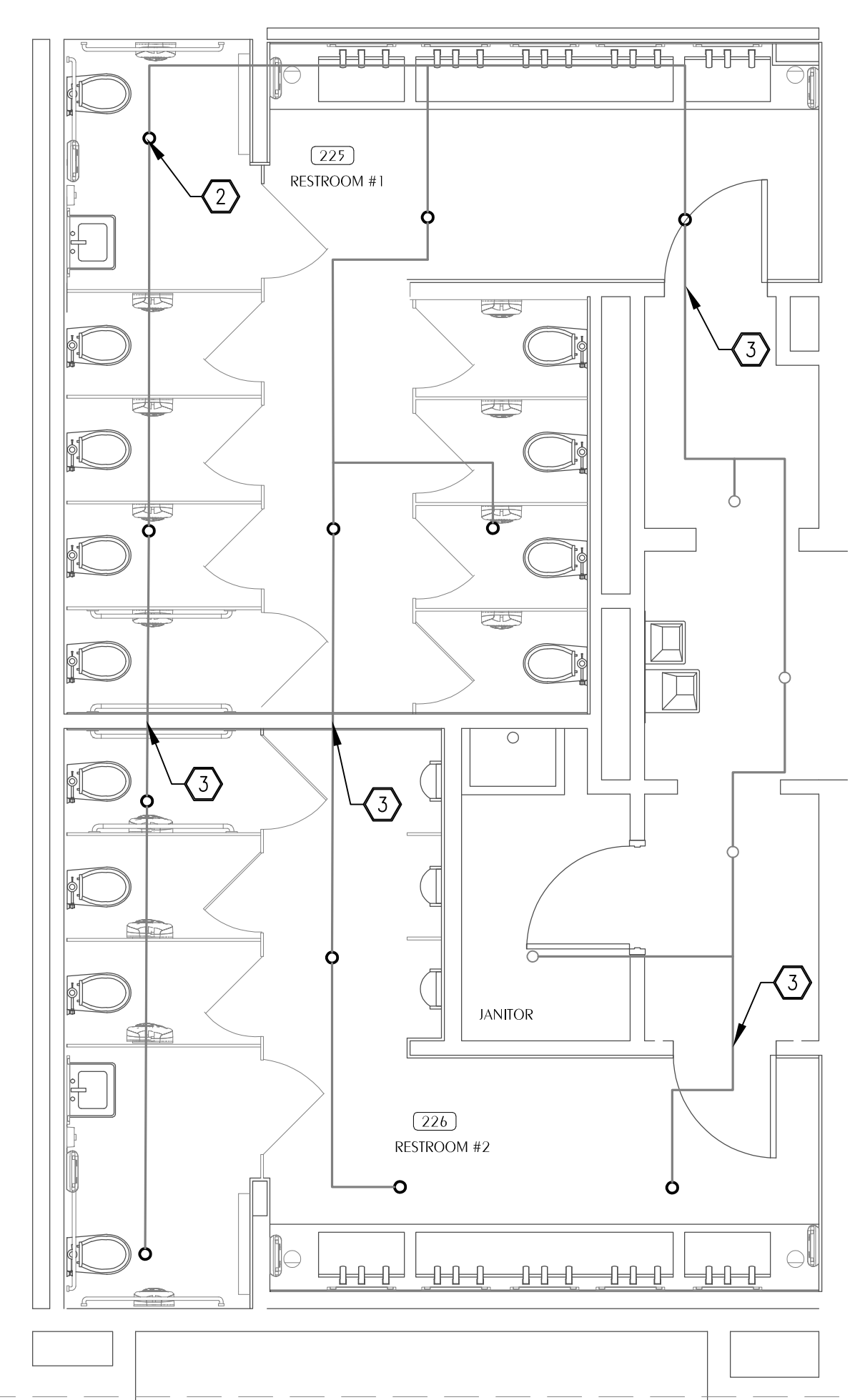

4 RESTROOM 1 & 2 FIRE PROTECTION NEW WORK PLAN
FP201 SCALE: 1/4" = 1'-0"

5 RESTROOM 3 & 4 FIRE PROTECTION NEW WORK PLAN
FP201 SCALE: 1/4" = 1'-0"

6 RESTROOM 5 & 6 FIRE PROTECTION NEW WORK PLAN
FP201 SCALE: 1/4" = 1'-0"

REVISIONS:

No.	Description	Date

FIRE PROTECTION
ENLARGED PLANS

Project number	17057.5
Dated	JANUARY 2019
PIC	DNW
PM	KAJ

FP201

Scale 1/4"=1'-0"

Watford Engineering, Inc.
Mechanical Consulting
4471 Clinton Street
Maitland, FL 32747
Florida CA Number: 27825
Project Number: 2018-8021
T: 850-526-3447
F: 850-526-3448
David N. Watford, PE
FL License Number: 38208

LEGEND

	EQUIPMENT TAG
	DETAIL TAG (*1" INDICATES IDENTIFICATION NUMBER, "M3" INDICATES THE SHEET NUMBER DRAWN ON)
	SHEET NOTE
	TYPICAL
	TEMPERATURE
	FLOOR DRAIN
	ABOVE FINISHED FLOOR
	DIRECT DIGITAL CONTROL
	VENTURI FLOW METER
	ANALOG INPUT
	ANALOG OUTPUT
	DIGITAL INPUT
	DIGITAL OUTPUT
	TESTING, ADJUSTING AND BALANCING
	NOMINAL
	EXISTING
	CEILING EXHAUST FAN
	ROOF TOP UNIT
	CEILING DIFFUSER
	RETURN GRILLE
	EXHAUST GRILLE
	SUPPLY GRILLE
	TRANSFER GRILLE
	RETURN REGISTER
	EXHAUST REGISTER
	SUPPLY DUCT SECTION POSITIVE PRESSURE
	RETURN OR EXHAUST DUCT NEGATIVE PRESSURE
	RECTANGULAR DUCT SIZE ("A" INDICATES SIDE SHOWN, "B" INDICATES SIDE NOT SHOWN)
	EXTERNALLY INSULATED DUCTWORK
	EXTERNALLY INSULATED ROUND FLEXIBLE DUCTWORK
	DUCT ELBOW WITH TURNING VANES
	RADIUSED DUCT ELBOW
	FLEXIBLE DUCT CONNECTION
	MANUAL VOLUME BALANCING DAMPER
	MOTORIZED DAMPER
	FIRE DAMPER WITH ACCESS DOORS
	TEE WITH TURNING VANES
	TRANSITION
	FLEX DUCT TAKE OFF WITH MVD SIZE EQUALS DIFFUSER NECK SIZE UNLESS NOTED OTHERWISE
	BRANCH DUCT TAKEOFF WITH MVD
	DUCT TO BE DEMOLISHED
	EXISTING DUCTWORK TO REMAIN
	AIR DEVICE TAG. TOP LINE INDICATES TYPE OF DEVICE BOTTOM LINE INDICATES AIRFLOW IN CFM
	POINT OF CONNECTION TO EXISTING
	THERMOSTAT. MOUNT 48" A.F.F. *1" INDICATES UNIT CONTROLLED.
	REMOTE MOUNTED TEMPERATURE SENSOR. MOUNT ON CEILING.

DUCTWORK NOTES

- ALL ROUND FLEXIBLE DUCT SHALL BE FLEXMASTER TYPE 8M ACOUSTICAL FLEX OR ENGINEER APPROVED EQUAL MAXIMUM LENGTH OF ANY FLEXIBLE DUCT RUNOUT SHALL BE 5'-0". WHERE LENGTH REQUIRED EXCEEDS 5'-0", INSTALL EXTERNALLY INSULATED ROUND SNAPLOCK DUCT FOR BALANCE OF DISTANCE TO SPIN-IN TAP AT MAIN DUCT TRUNK.
- SEAL ALL DUCT PENETRATIONS OF WALLS AND FLOORS AIRTIGHT, REGARDLESS OF WHETHER WALLS OR FLOORS ARE FIRE RATED OR NOT.
- ALL SUPPLY AIR DUCTWORK FROM AHUS (EXCEPT TAKEOFFS TO SUPPLY AIR DIFFUSERS) SHALL BE LOW PRESSURE RECTANGULAR, SMACNA STATIC PRESSURE CLASS 2" W.G., SEAL CLASS A, EXTERNALLY INSULATED WITH 2" FLEXIBLE INSULATION CONFORMING TO ASTM C553, TYPE 1, CLASS B-3 WITH 1 PCF DENSITY AND UL RATED ALUMINUM FOIL VAPOR BARRIER (FSK) UNLESS OTHERWISE INDICATED. DUCT SIZES INDICATED ARE INSIDE CLEAR DIMENSIONS.
- ALL RETURN AIR DUCTWORK SHALL BE LOW PRESSURE RECTANGULAR, SMACNA STATIC PRESSURE CLASS 2" W.G., SEAL CLASS A, EXTERNALLY INSULATED WITH 2" FLEXIBLE INSULATION CONFORMING TO ASTM C553, TYPE 1, CLASS B-3 WITH 1 PCF DENSITY AND UL RATED ALUMINUM FOIL VAPOR BARRIER (FSK) UNLESS OTHERWISE INDICATED. DUCT SIZES INDICATED ARE INSIDE CLEAR DIMENSIONS.
- STANDARD EXHAUST AIR DUCTWORK SHALL BE LOW PRESSURE RECTANGULAR, SMACNA STATIC PRESSURE CLASS 1/2" W.G., SEAL CLASS A, SHEET METAL.
- WHEN ROUTING DUCTWORK OVER LIGHTS, PROVIDE A MINIMUM 6" CLEARANCE BETWEEN DUCT AND LIGHTS.
- CONTRACTOR SHALL SUBMIT COORDINATED DUCTWORK SHOP DRAWINGS INDICATING COORDINATION WITH ELECTRICAL, PLUMBING, AND FIRE PROTECTION, PRIOR TO BEGINNING WORK. SHOP DRAWINGS SHALL INCLUDE LOCATIONS OF THERMOSTATS, ACCESS PANELS, AIR DEVICES, DUCTWORK, ETC.

AIR DEVICE SCHEDULE

MARK	MAX AIRFLOW CFM	AIR DEVICE SIZE	DUCT CONNECTION SIZE	TITUS MODEL
CD-1 CFM	80	9x9	60	TDC
CD-2 CFM	550	24x24	140	TMSA
RC, EG, SG, TG, RR, ER				
xx-1 CFM	450	12x12	12x12	350FL
xx-2 CFM	1705	22x22	22x22	350FL

- NOTES:
- MAX NC=20
 - PROVIDE 2x2 LAY IN PANEL FOR AIR DEVICES IN LAY IN CEILING.
 - PROVIDE BEVELED MOUNTING FRAME FOR CEILING DIFFUSERS IN HARD CEILING.
 - PROVIDE FLAT MOUNTING FRAME FOR GRILLES LOCATED IN HARD CEILING.
 - PROVIDE TMSA DIFFUSER IN VERTICAL OPERATION.

EXISTING EXHAUST FAN SCHEDULE

UNIT	TYPE	CFM
EF-3(E)	CEF	1125
EF-5(E)	CEF	975
EF-6(E)	CEF	905

PACKAGED ROOFTOP UNIT HEAT PUMP SCHEDULE

UNIT	BASIS OF DESIGN	MODEL	SA (CFM)	OA (CFM)	ESP (IN.H2O)	FAN (HP)	COOLING			HEATING			SUPPL. HEAT	RTU ELECTRICAL VOLTS/PHASE	MCA	MOP	NOTES			
							MAT* (DB/WB)	OAT* (DB)	TOTAL (BTUH)	MAT* (DB)	OAT* (DB)	TOTAL (BTUH)								
RTU-1	LENNOX	KHB024H4E	1025	0	0.35	0.33	72.1/60.3	95.0/78.0	20900	19900	16.5	69.4	25	22500	8.3	7.5kW	208/1	54.0	60	1,2,3,4,5,6,7,8,9,10,11
RTU-2	LENNOX	KHB024H4E	880	0	0.35	0.33	72.4/60.8	95.0/78.0	17900	17000	16.5	69.8	25	20400	8.3	7.5kW	208/1	54.0	60	1,2,3,4,5,6,7,8,9,10,11
RTU-3	LENNOX	KHB024H4E	975	0	0.35	0.33	72.4/61.0	95.0/78.0	19300	18300	16.5	69.8	25	23300	8.3	7.5kW	208/1	54.0	60	1,2,3,4,5,6,7,8,9,10,11

- PROVIDE 2" x 30% FILTERS AND FILTER HOUSING SHOWN IN DETAILS.
- EFFICIENCIES IN ACCORDANCE WITH ARI STANDARD 210/240.
- ESP DOES NOT INCLUDE FILTER, CASING, ETC.
- PROVIDE CONTROL KIT TO INCLUDE BLOWER CONTACTOR OR STARTER, TRANSFORMER, ELECTRIC HEATER INTERLOCKS. ELECTRICAL SERVICE SHALL BE A SINGLE POINT OF CONNECTION.
- PROVIDE THERMAL EXPANSION VALVES.
- DIRECT DRIVE AHU FAN.
- COOLING CAPACITY IS NET AND DOES NOT INCLUDE FAN HEAT.
- PROVIDE POWERED 120V CONVENIENCE OUTLET.
- PROVIDE THROUGH THE BASE ELECTRICAL CONNECTIONS.
- PROVIDE ROOF CURB 12" ABOVE FINISHED SURFACE OF ROOF.
- PROVIDE NEW PROGRAMMABLE THERMOSTAT WITH REMOTE MOUNTED TEMPERATURE SENSOR.

GENERAL NOTES

- ALL DUCT DIMENSIONS ARE NET INSIDE.
- VERIFY COLLAR SIZES ON ALL AIR TERMINALS, EQUIPMENT OUTLETS AND INLETS, TRANSITION DUCTWORK AS NECESSARY. EXTERNALLY INSULATE TRANSITIONS AT EQUIPMENT CONNECTIONS.
- FIELD VERIFY CLEAR SPACE AVAILABLE, ROUTING PATH, AND CONFLICTS WITH STRUCTURE AND THE WORK OF OTHER TRADES PRIOR TO FABRICATING DUCTWORK. PROVIDE OFFSETS IN DUCTWORK AS REQUIRED, WHETHER SPECIFICALLY INDICATED ON DRAWINGS OR NOT. SUBMIT SHOP DRAWINGS ON DUCTWORK LAYOUT PRIOR TO COMMENCING WORK. MAINTAIN CLEARANCE AROUND ALL LIGHT FIXTURES AS REQUIRED TO REMOVE AND SERVICE FIXTURES. COORDINATE WITH ROOF TRUSSES/STRUCTURE. PRESSURE TEST ALL NEW DUCTWORK FOR LEAKS. SEE SPECIFICATIONS.
- CONTRACTOR SHALL INSTALL ALL EQUIPMENT, PIPING, AND DUCTWORK SUCH THAT MANUFACTURERS' RECOMMENDED CLEARANCES ARE MET FOR ALL ACCESS PANELS, MOTORS, FANS, BELTS, FILTERS AND AIR INTAKES. CONDENSATE LINES SHALL BE CLEAR OF FILTER RACK ACCESS.
- PROVIDE DUCT FLEX CONNECTIONS & VIBRATION ISOLATION FOR ALL UNITS NOT INTERNALLY ISOLATED.
- ALL SUPPLY, RETURN, EXHAUST AND OUTSIDE AIR INTAKE DUCTWORK SHALL BE GALVANIZED SHEET METAL.
- ALL RTU FILTERS SHALL BE OF A READILY AVAILABLE SIZE, OF DISPOSABLE TYPE, AND BE ACCESSIBLE WITHOUT THE USE OF SCREWS OR OTHER MECHANICAL DEVICES REQUIRING TOOLS.
- PROVIDE ACCESS PANELS IN CEILING AS REQUIRED FOR MAINTENANCE AND ADJUSTMENT OF EQUIPMENT LOCATED ABOVE CEILING. COORDINATE ALL SIZES AND LOCATIONS WITH ARCHITECT DURING SUBMITTALS. PROVIDE PLANS IF REQUIRED BY ARCHITECT.
- CONTRACTOR IS RESPONSIBLE FOR FIELD VERIFYING LOCATION OF ALL EQUIPMENT AND UTILITIES.
- CONTRACTOR SHALL SUBMIT COORDINATED DUCTWORK SHOP DRAWINGS INDICATING COORDINATION WITH ELECTRICAL, PLUMBING, AND FIRE PROTECTION, PRIOR TO BEGINNING WORK. SHOP DRAWINGS SHALL INCLUDE LOCATIONS OF THERMOSTATS, ACCESS PANELS, AIR DEVICES, DUCTWORK, ETC.
- ALL WORK SHALL COMPLY WITH SIXTH EDITION (2017) FLORIDA BUILDING CODE, MECHANICAL.

SEQUENCE OF OPERATION PACKAGED ROOFTOP HEAT PUMP UNIT

THE FOLLOWING SEQUENCE OF OPERATIONS SHALL BE PROVIDED BY THE UNIT MANUFACTURER.

GENERAL: STARTING AND STOPPING OF EQUIPMENT SHALL BE BY THE UNIT MOUNTED CONTROLLER. WITH THE UNIT MOUNTED CONTROLLER IN THE AUTO MODE, THE UNIT SHALL BE STARTED AUTOMATICALLY BY THE ELECTRONIC CONTROL SYSTEM AND ALL CONTROLS ACTIVATED SUBJECT TO THE FIRE ALARM RELAY, SAFETIES AND OVERLOADS. ZONE TEMPERATURE SENSORS SHALL BE PROVIDED WITH A COMMUNICATIONS JACK.

OCCUPIED MODE: THE INDOOR FAN SHALL RUN CONTINUOUSLY. THE CONDENSING UNIT SHALL CYCLE TO MAINTAIN SPACE TEMPERATURE. THE SETPOINT FOR COOLING SHALL BE 75°F ADJUSTABLE. THE SETPOINT FOR HEATING SHALL BE 70°F ADJUSTABLE. THE HP SHALL CYCLE TO MAINTAIN SPACE TEMPERATURE. THE ELECTRIC HEAT SHALL BE AVAILABLE AS EMERGENCY HEAT AND AN ADDITIONAL STAGE OF HEAT WHEN THE OUTDOOR AIR TEMPERATURE FALLS BELOW 35°F.

UNOCCUPIED MODE: THE INDOOR FAN AND CONDENSING UNIT SHALL CYCLE TO MAINTAIN SETPOINT TEMPERATURE. THE SETPOINT FOR COOLING SHALL BE 80°F ADJUSTABLE. THE SETPOINT FOR HEATING SHALL BE 65°F ADJUSTABLE.

VERRIDE MODE: THE OVERRIDE MODE SHALL PLACE THE SYSTEM IN OCCUPIED MODE.

HUMIDITY CONTROL:

WHEN TEMPERATURE AND HUMIDITY ARE NOT SATISFIED IN THE SPACE, THE UNIT SHALL ENTER SUBCOOLING MODE. THE UNIT SHALL SUBCOOL HOT LIQUID REFRIGERANT LEAVING THE CONDENSER COIL.

UPON A RISE IN SPACE RELATIVE HUMIDITY ABOVE SETPOINT AND NO CALL FOR COOLING, THE UNIT CONTROLLER SHALL PLACE THE CONDENSING UNIT IN COOLING MODE AND UTILIZE THE HOT GAS REHEAT TO DEHUMIDIFY AND REHEAT SUPPLY AIR TO NEUTRAL CONDITIONS UNTIL THE CALL FOR DEHUMIDIFICATION HAS BEEN SATISFIED.



OWNERSHIP OF SERVICE:
ALL REPORTS, PLANS, SPECIFICATIONS, COMPUTER FILES, FIELD DATA, NOTES AND OTHER DOCUMENTS AND INSTRUMENTS PREPARED BY THE CONSULTANT AS AN INSTRUMENT OF SERVICE SHALL REMAIN THE PROPERTY OF THE CONSULTANT. THE CONSULTANT SHALL RETAIN ALL COMMON LAW, STATUTORY AND OTHER RESERVED RIGHTS, INCLUDING THE COPYRIGHT THEREIN.

PURSUANT TO FLORIDA STATUTES, SECTION 690.005, AN INDIVIDUAL EMPLOYEE OR AGENT MAY NOT BE HELD INDIVIDUALLY LIABLE FOR NEGLIGENCE.

BID DOCUMENTS

EMERALD COAST CONVENTION CENTER
RESTROOM RENOVATIONS & MEETING ROOM
COUNTERS
TASK ORDER NO. 5 - C-18-2638-TDD
1250 MIRACLE STRIP PKWY SE
FORT WALTON BEACH, FL 32548

REVISIONS:

No.	Description	Date

MECHANICAL LEGEND, SCHEDULE, & NOTES

Project number	17057.5
Dated	JANUARY 2019
PIE	DNW
PM	KAJ

M001

Scale NONE

Watford Engineering, Inc.
Mechanical Consulting
4471 Clinton Street
Merrittville, FL 32446
Florida CA Number: 27885
Project Number: 2018-021

T: 850-526-3447
F: 850-526-3448
David N. Watford, PE
FL License Number: 38208



OWNERSHIP OF SERVICE:
 ALL REPORTS, PLANS, SPECIFICATIONS, COMPUTER FILES,
 FIELD DATA, NOTES AND OTHER DOCUMENTS AND
 INSTRUMENTS PREPARED BY THE CONSULTANT AS AN
 INSTRUMENT OF SERVICE SHALL REMAIN THE PROPERTY OF
 THE CONSULTANT. THE CONSULTANT SHALL RETAIN ALL
 COMMON LAW, STATUTORY AND OTHER RESERVED RIGHTS,
 INCLUDING THE COPYRIGHT THEREIN.

PURSUANT TO FLORIDA STATUTES, SECTION 690.005, AN
 INDIVIDUAL EMPLOYEE OR AGENT MAY NOT BE HELD
 INDIVIDUALLY LIABLE FOR NEGLIGENCE.

BID DOCUMENTS

EMERALD COAST CONVENTION CENTER
**RESTROOM RENOVATIONS & MEETING ROOM
 COUNTERS**
 TASK ORDER NO. 5 - C-18-2638-TDD
 1250 MIRACLE STRIP PKWY SE
 FORT WALTON BEACH, FL 32548

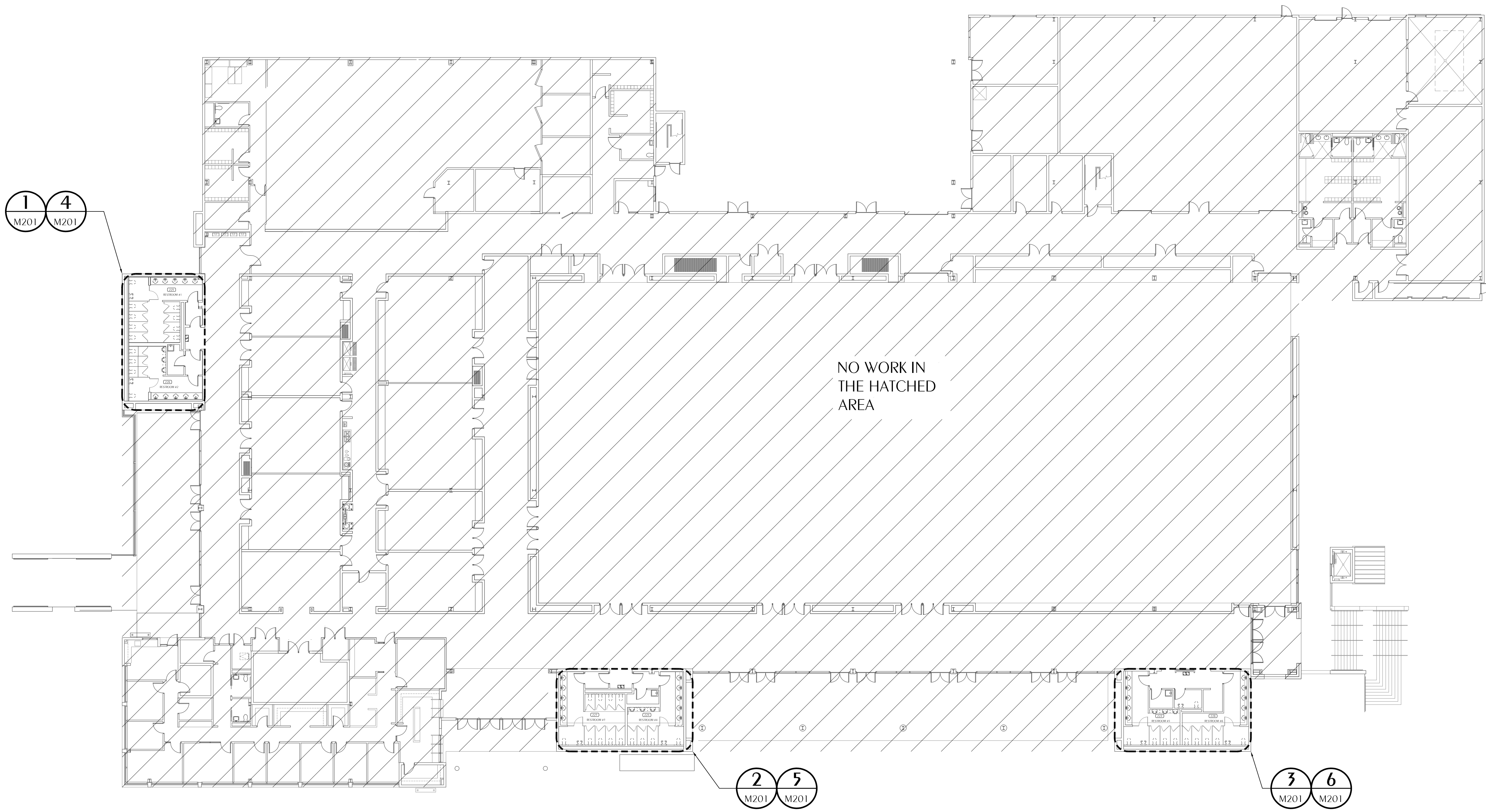

1 MECHANICAL OVERALL PLAN
 M101 SCALE: 1/16" = 1'-0"

REVISIONS:

No.	Description	Date

MECHANICAL
 OVERALL PLAN

Project number	17057.5
Dated	JANUARY 2019
PIC	DNW
PM	KAJ

M101
 Scale 1/16"=1'-0"

Watford Engineering, Inc.
 Mechanical Consulting
 4471 Clinton Street
 Marianna, FL 32446
 Florida CA Number: 27825
 Project Number: 2018-021

T: 850-526-3447
 F: 850-526-3448
 David N. Watford, PE
 FL License Number: 38208



DISCLAIMER OF SERVICES
ALL REPORTS, PLANS, SPECIFICATIONS, COMPUTER FILES,
FIELD DATA, NOTES AND OTHER DOCUMENTS AND
INSTRUMENTS PREPARED BY THE CONSULTANT AS AN
INSTRUMENT OF SERVICES SHALL REMAIN THE PROPERTY OF
THE CONSULTANT. THE CONSULTANT SHALL RETAIN ALL
COMMON LAW, STATUTORY AND OTHER RESERVED RIGHTS,
INCLUDING THE COPYRIGHT THEREIN.

PURSUANT TO FLORIDA STATUTES, SECTION 690.005, AN
INDIVIDUAL EMPLOYEE OR AGENT MAY NOT BE HELD
INDIVIDUALLY LIABLE FOR NEGLIGENCE.

BID DOCUMENTS

EMERALD COAST CONVENTION CENTER
**RESTROOM RENOVATIONS & MEETING ROOM
COUNTERS**
TASK ORDER NO. 5 - C-18-2638-TDD
1250 MIRACLE STRIP PKWY SE
FORT WALTON BEACH, FL 32548

SHEET NOTES

- 1 REMOVE EXISTING AIR DEVICE. TYPICAL.
- 2 REMOVE SECTION OF DUCTWORK AS SHOWN.
- 3 REMOVE PORTION OF EXISTING DUCTWORK FOR INSTALLATION OF NEW FIRE DAMPER.
- 4 PROVIDE 2'-0"x2'-0" ACCESS DOOR IN CEILING TO ALLOW ACCESS TO FIRE DAMPER.

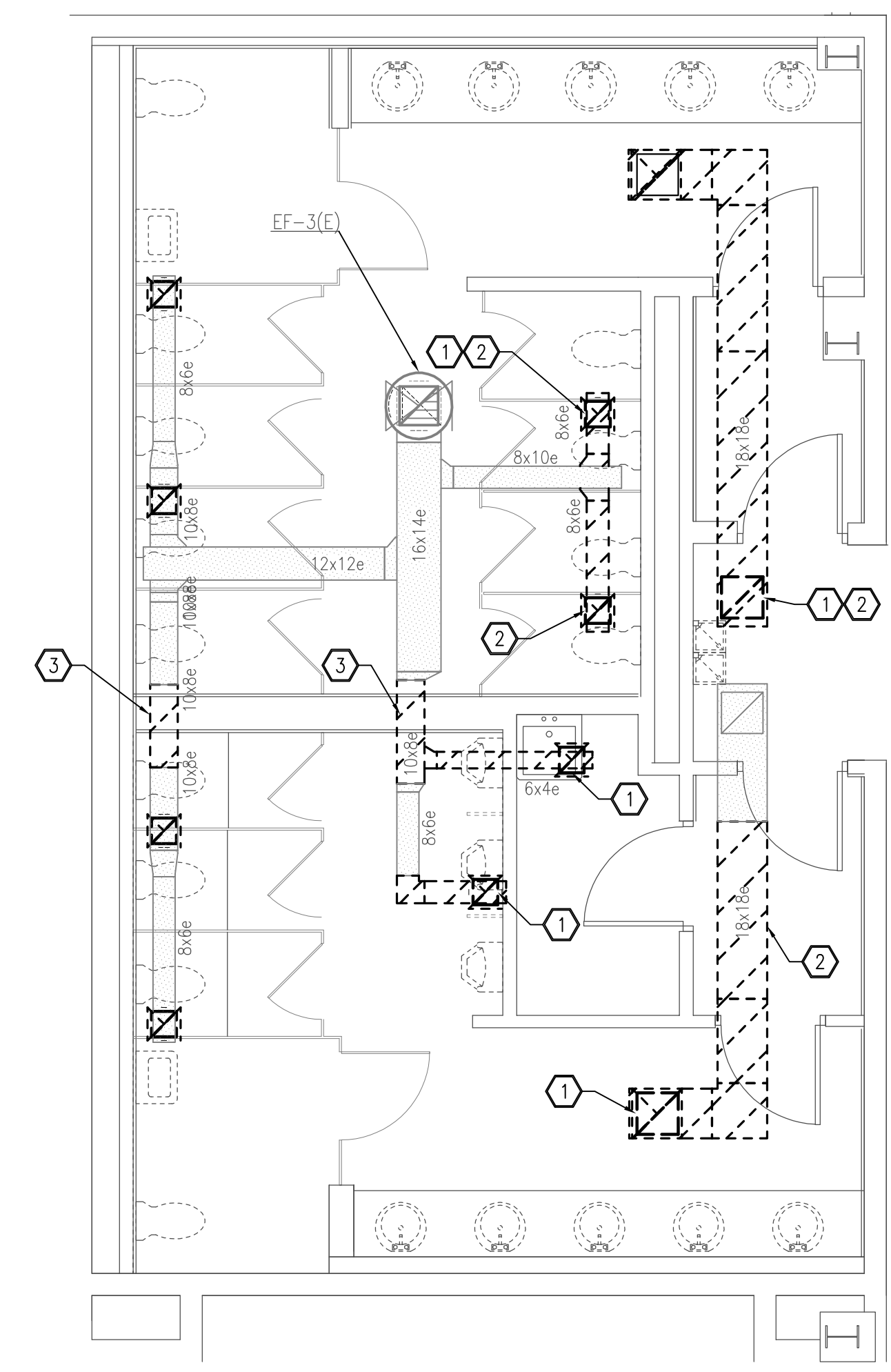

1 RESTROOM 1 & 2 MECHANICAL DEMOLITION PLAN
M201 SCALE: 1/4" = 1'-0"

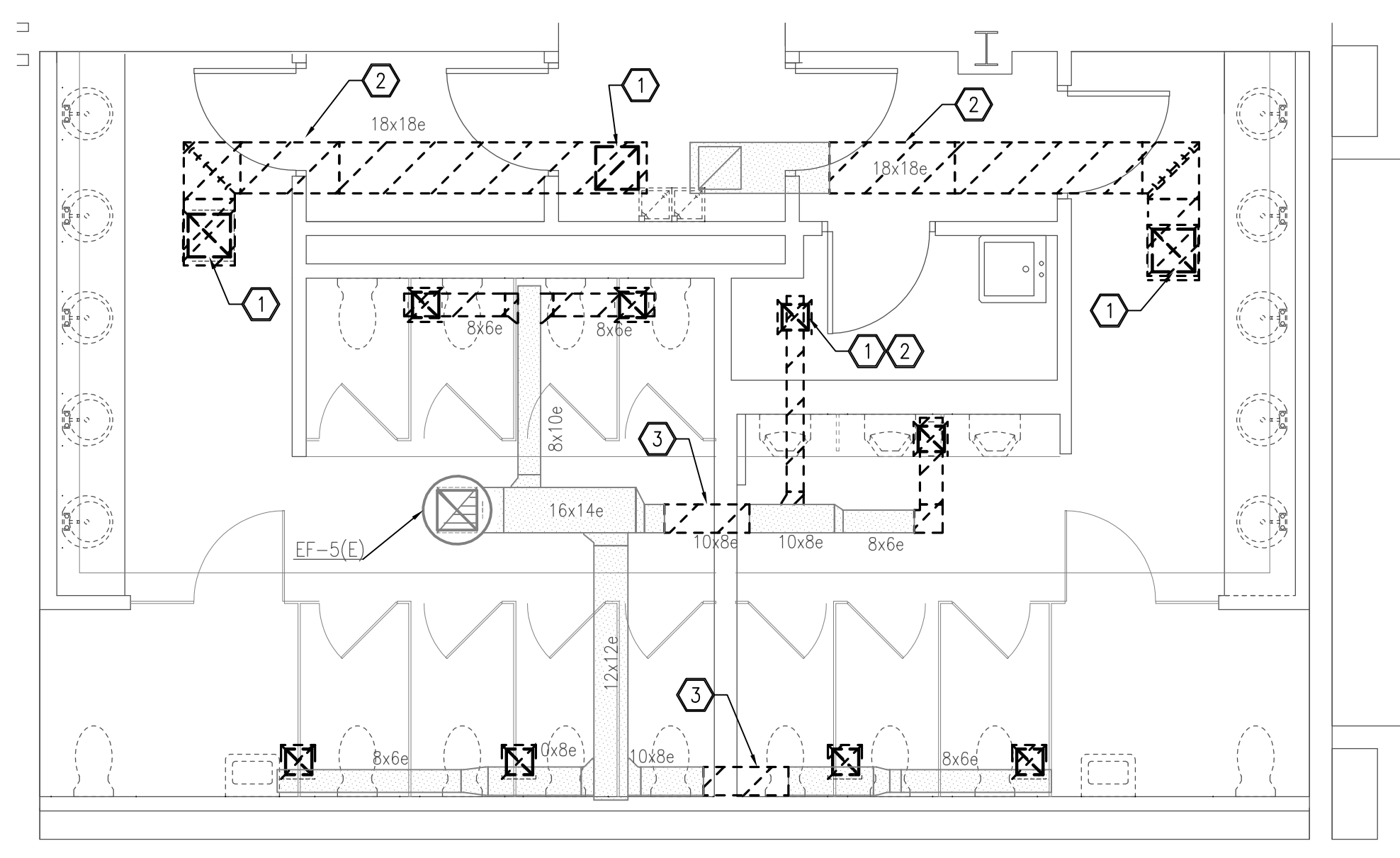

2 RESTROOM 3 & 4 MECHANICAL DEMOLITION PLAN
M201 SCALE: 1/4" = 1'-0"

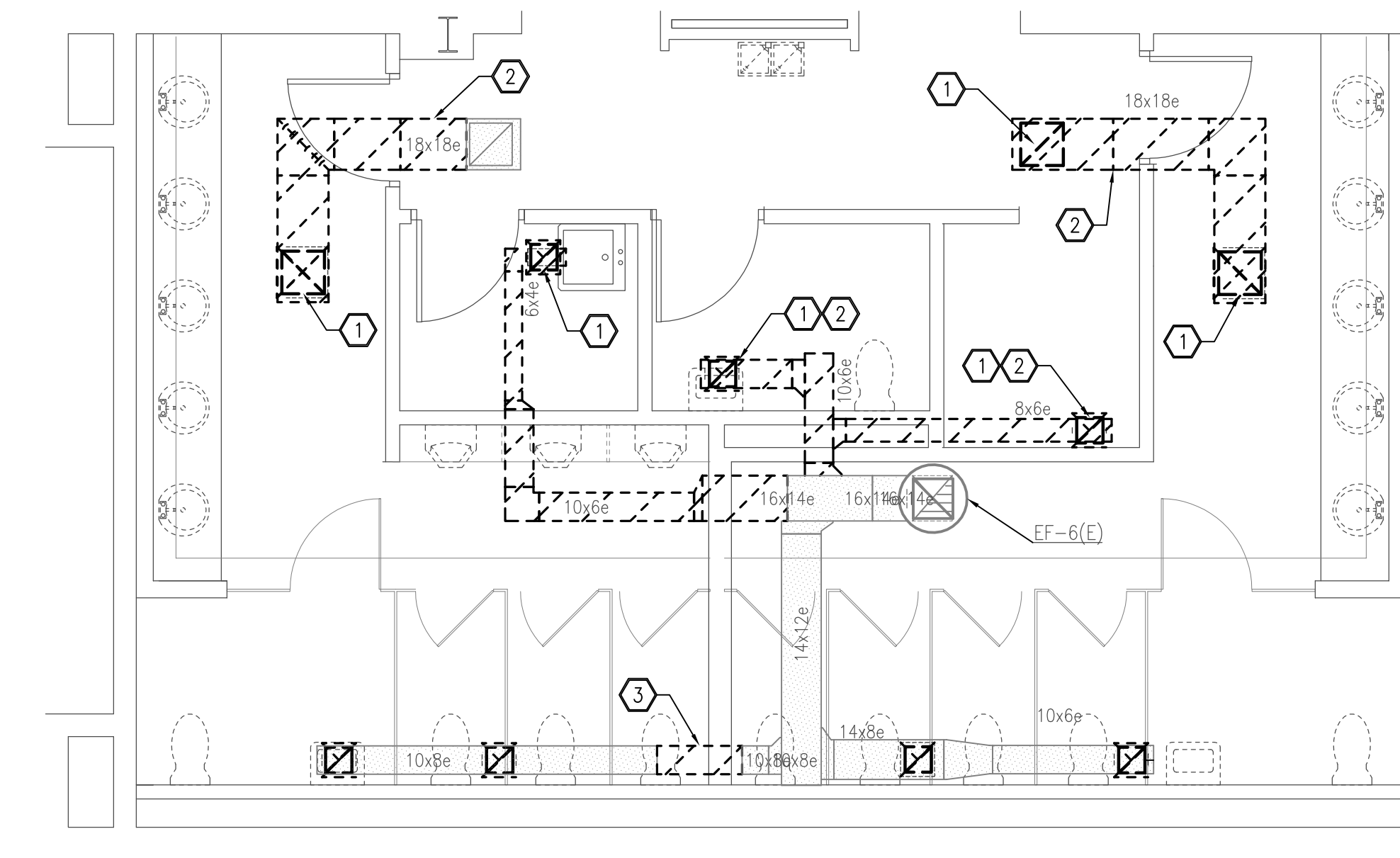

3 RESTROOM 5 & 6 MECHANICAL DEMOLITION PLAN
M201 SCALE: 1/4" = 1'-0"

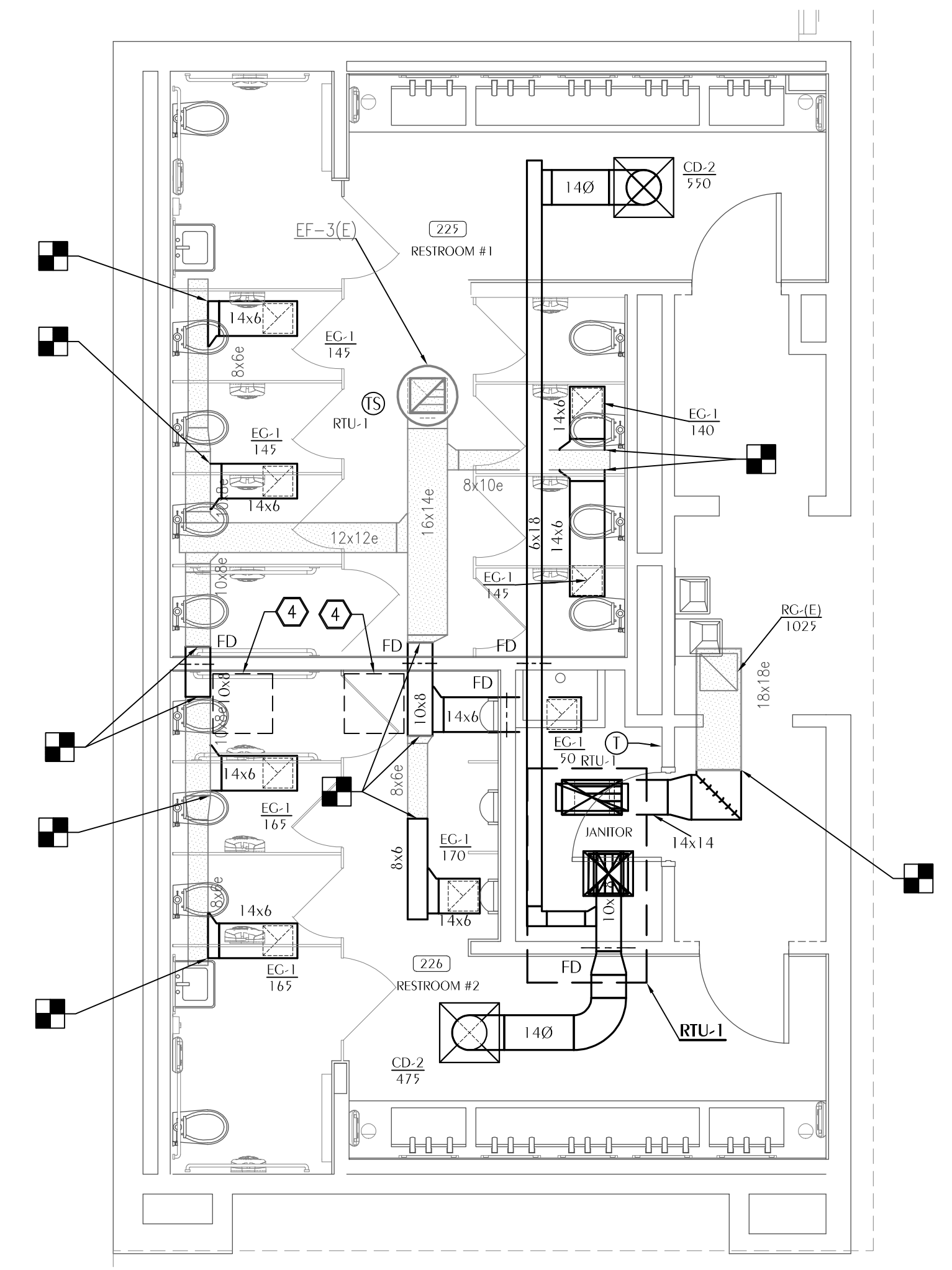

4 RESTROOM 1 & 2 MECHANICAL NEW WORK PLAN
M201 SCALE: 1/4" = 1'-0"

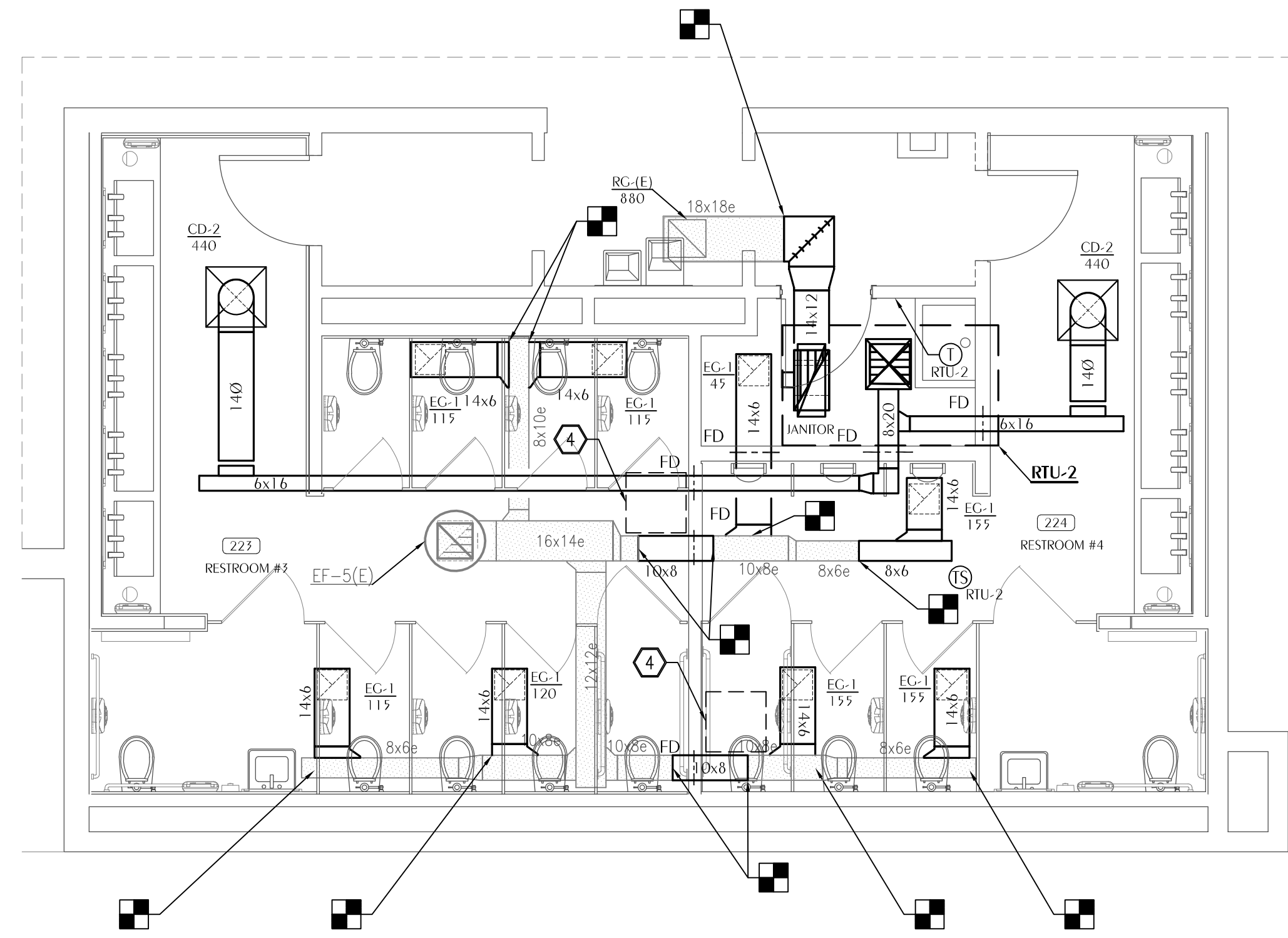

5 RESTROOM 3 & 4 MECHANICAL NEW WORK PLAN
M201 SCALE: 1/4" = 1'-0"

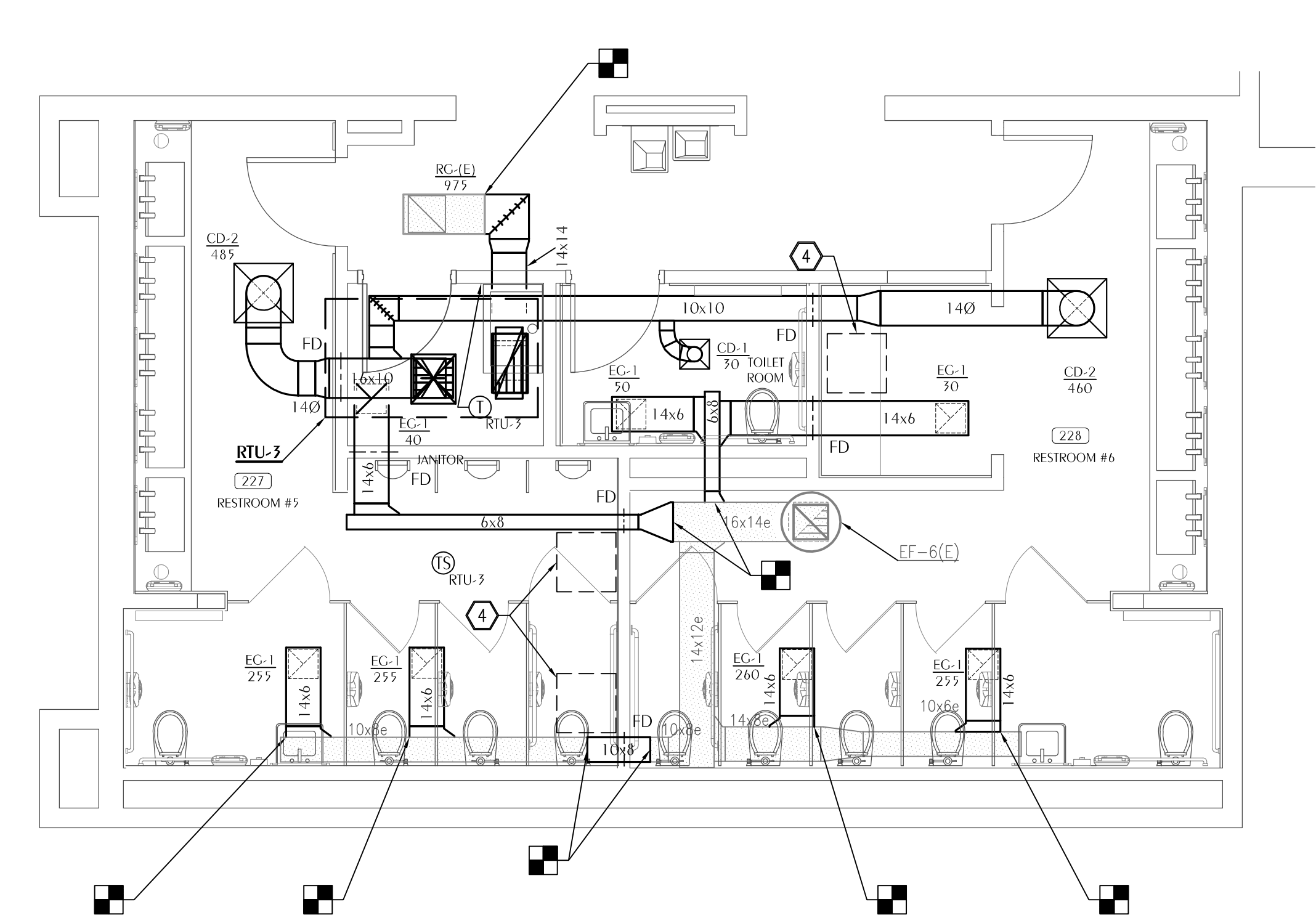

6 RESTROOM 5 & 6 MECHANICAL NEW WORK PLAN
M201 SCALE: 1/4" = 1'-0"

REVISIONS:

No.	Description	Date

ENLARGED
MECHANICAL PLANS

Project number	17057.5
Dated	JANUARY 2019
PIC	DNW
PM	KAJ
M201	
Scale	1/4"=1'-0"

Watford Engineering, Inc.
Mechanical Consulting
4471 Clinton Street
Marianna, FL 32447
Florida CA Number: 27825
Project Number: 2018-021

T: 890-528-3447
F: 890-528-3448
David N. Watford, PE
FL License Number: 38208



OWNERSHIP OF SERVICE:
ALL REPORTS, PLANS, SPECIFICATIONS, COMPUTER FILES, FIELD DATA, NOTES AND OTHER DOCUMENTS AND INSTRUMENTS PREPARED BY THE CONSULTANT AS AN INSTRUMENT OF SERVICE SHALL REMAIN THE PROPERTY OF THE CONSULTANT. THE CONSULTANT SHALL RETAIN ALL COMMON LAW, STATUTORY AND OTHER RESERVED RIGHTS, INCLUDING THE COPYRIGHT THEREIN.

PURSUANT TO FLORIDA STATUTES, SECTION 690.005, AN INDIVIDUAL EMPLOYEE OR AGENT MAY NOT BE HELD INDIVIDUALLY LIABLE FOR NEGLIGENCE.

BID DOCUMENTS

EMERALD COAST CONVENTION CENTER
RESTROOM RENOVATIONS & MEETING ROOM
COUNTERS
TASK ORDER NO. 5 - C-18-2638-TDD
1250 MIRACLE STRIP PKWY SE
FORT WALTON BEACH, FL 32548

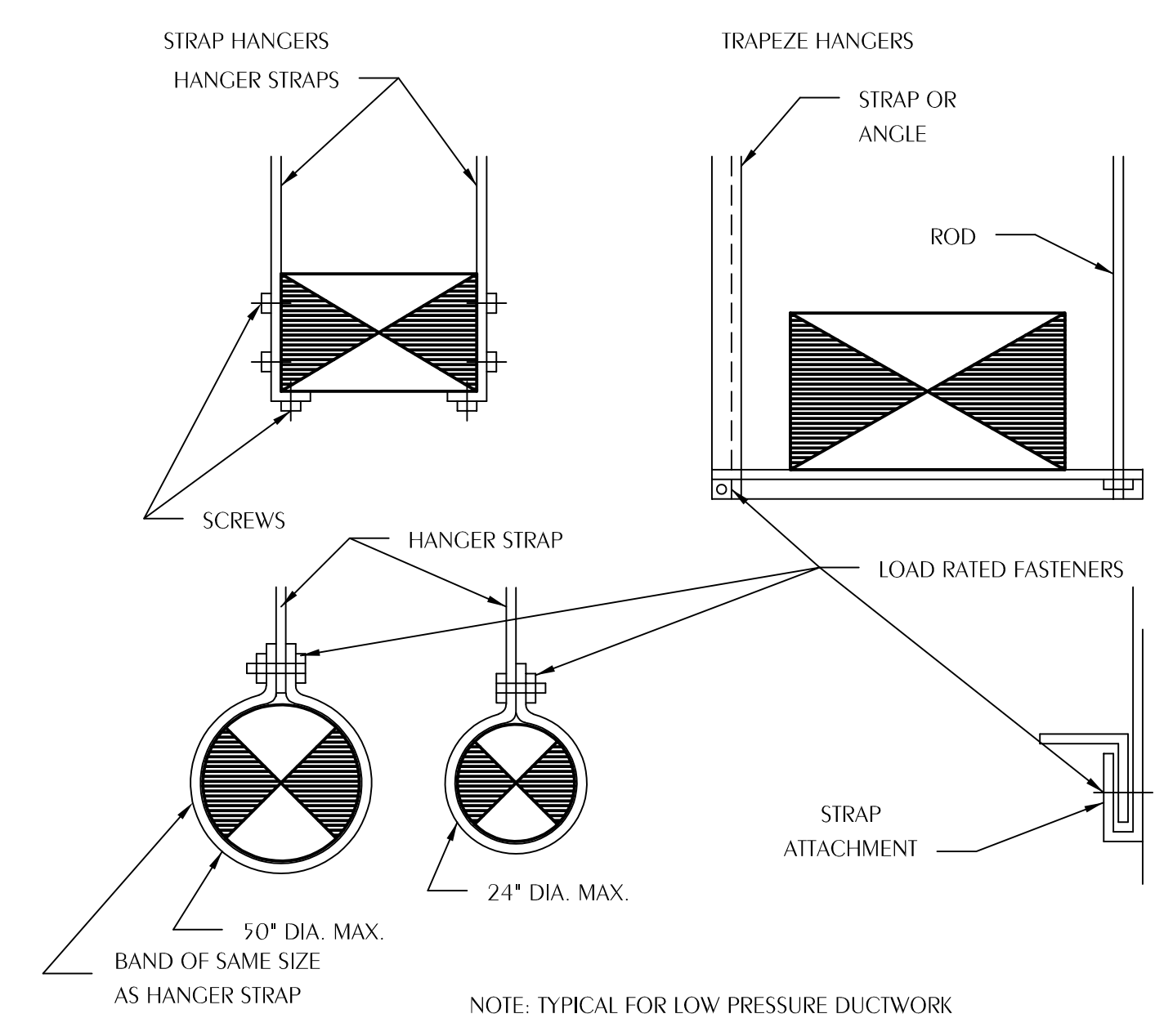

1 DUCT HANGER DETAILS
M301 SCALE: NONE

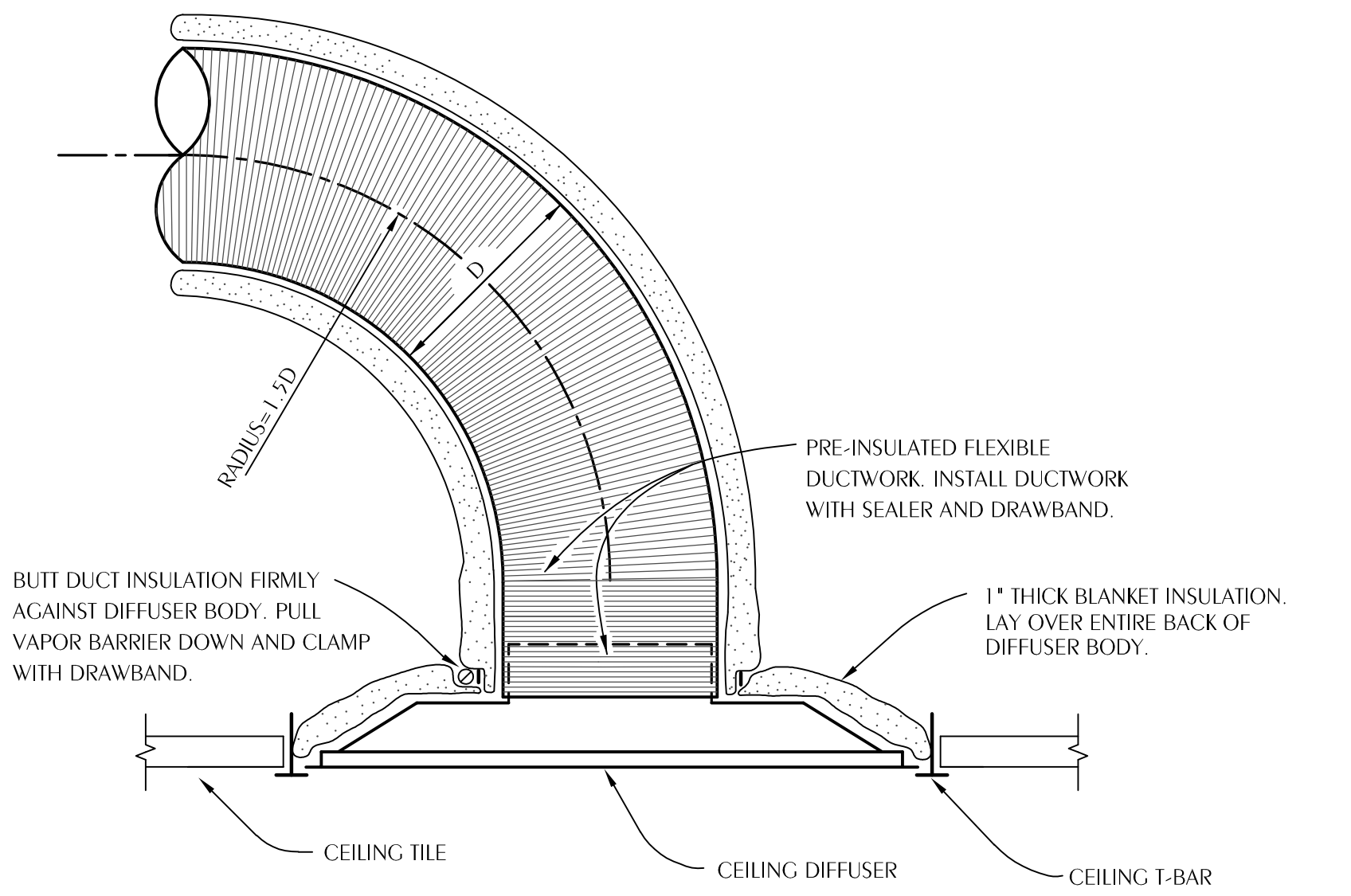

NOTES:
FLEX DUCT SHALL BE NO LONGER THAN 5'-0". FLEXIBLE DUCT SHALL HAVE REINFORCED, METALIZED POLYESTER JACKET WITH NO FIBERGLASS EROSION IN THE AIRSTREAM AND AN ENCAPSULATED WIRE HELIX. FLEX DUCT SHALL HAVE OPERATING PRESSURE OF 6" W.G. AND NEGATIVE OPERATING PRESSURE OF 0.75" W.G. FLEX DUCT SHALL HAVE R-VALUE OF R-6 AND MEET REQUIREMENTS OF UL-181, 2017 FLORIDA ENERGY CODE, NFPA 90A AND NFPA 90B. AICO 76 OR APPROVED EQUAL.
PROVIDE 24x24 LAY IN PANEL FOR DIFFUSERS IN LAY IN CEILINGS.
PROVIDE BEVELED MOUNTING FRAME FOR DIFFUSERS IN HARD CEILINGS.

2 TYPICAL FLEX DUCT TAKEOFF DETAIL
M301 SCALE: NONE

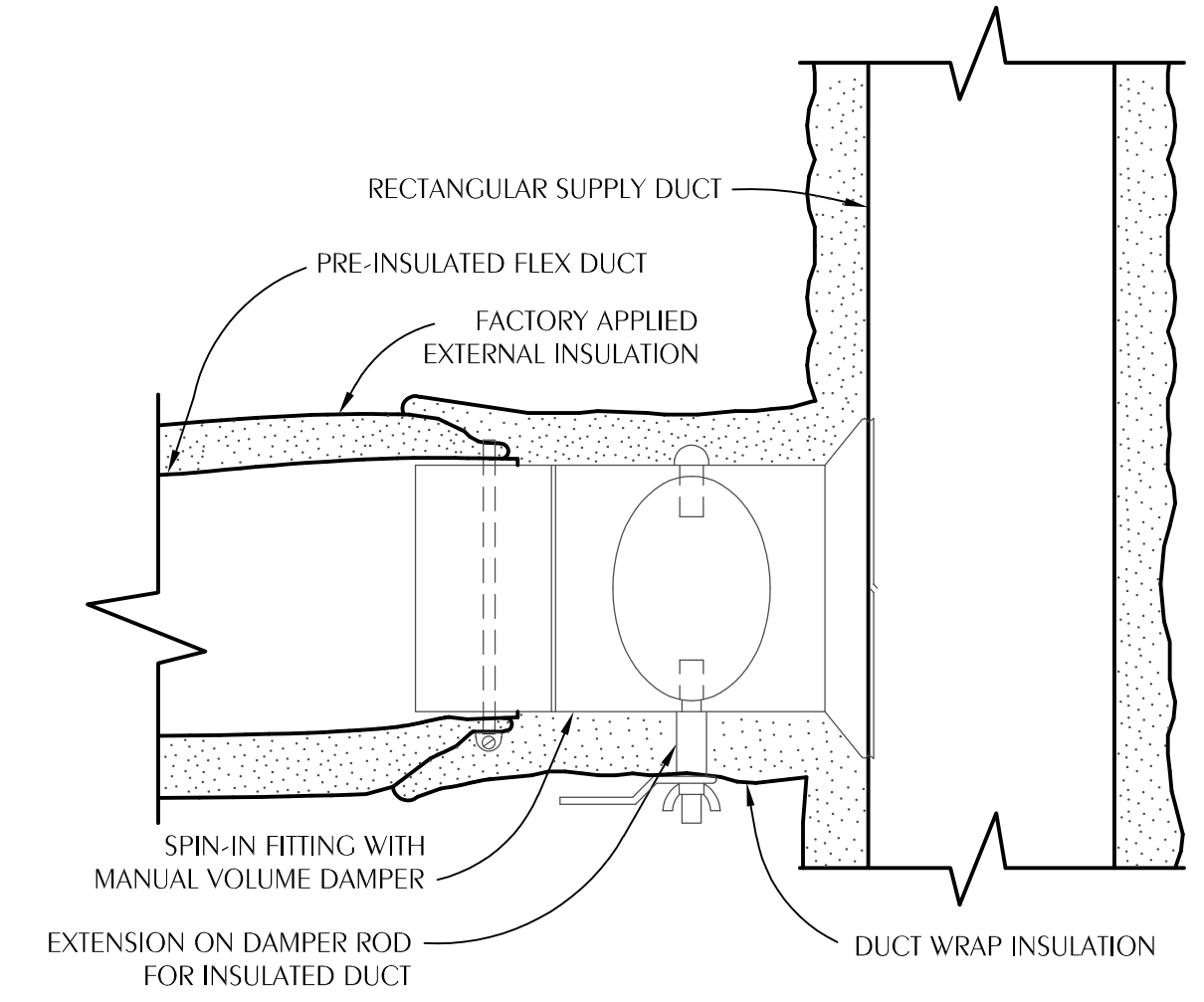

NOTES:
CONNECT FLEXIBLE DUCT TO FITTING WITH DRAWBAND AND SEALER.
ROUND HARD DUCT RUNOUTS SHOULD START WITH SPIN-IN FITTINGS SIMILAR TO THIS DETAIL.
PROVIDE CABLE ACTIVATED DAMPER WITH ADJUSTMENT IN FACE OF CEILING DIFFUSER.
FLEXIBLE INSULATION SHALL BE 2" THICK, ASTM C553, TYPE 1, CLASS B-3 WITH 1 PCF DENSITY AND UL RATED ALUMINUM FOIL VAPOR BARRIER (FSK)

3 TYPICAL FLEX DUCT TAKEOFF DETAIL
M301 SCALE: NONE

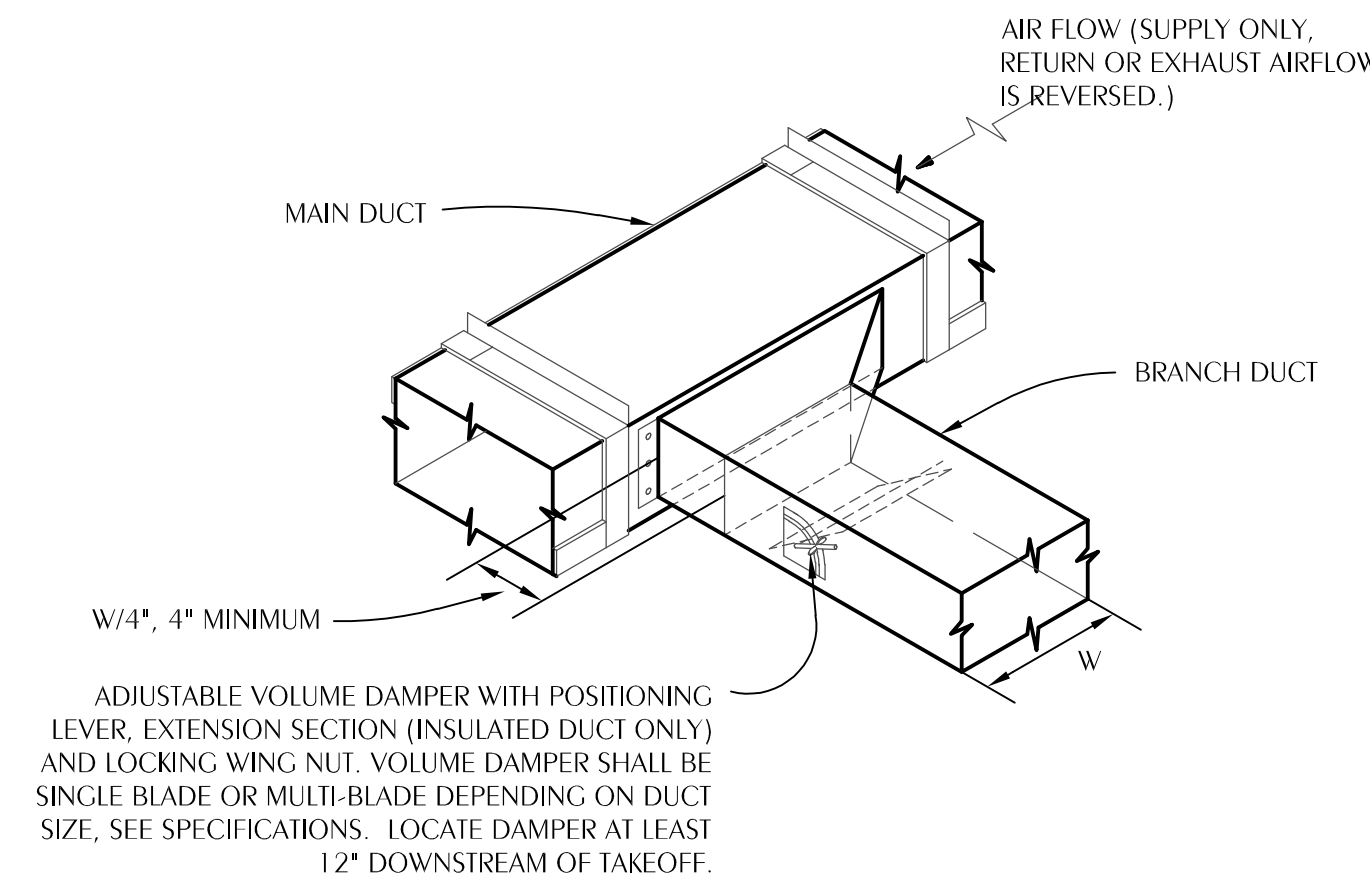

ADJUSTABLE VOLUME DAMPER WITH POSITIONING LEVER, EXTENSION SECTION (INSULATED DUCT ONLY) AND LOCKING WING NUT. VOLUME DAMPER SHALL BE SINGLE BLADE OR MULTI-BLADE DEPENDING ON DUCT SIZE. SEE SPECIFICATIONS. LOCATE DAMPER AT LEAST 12" DOWNSTREAM OF TAKEOFF.

NOTES:
PROVIDE CABLE ACTIVATED DAMPER WITH ADJUSTMENT IN FACE OF CEILING DIFFUSER.
FLEXIBLE INSULATION SHALL BE 2" THICK, ASTM C553, TYPE 1, CLASS B-3 WITH 1 PCF DENSITY AND UL RATED ALUMINUM FOIL VAPOR BARRIER (FSK)

4 TYPICAL BRANCH DUCT TAKEOFF
M301 SCALE: NONE

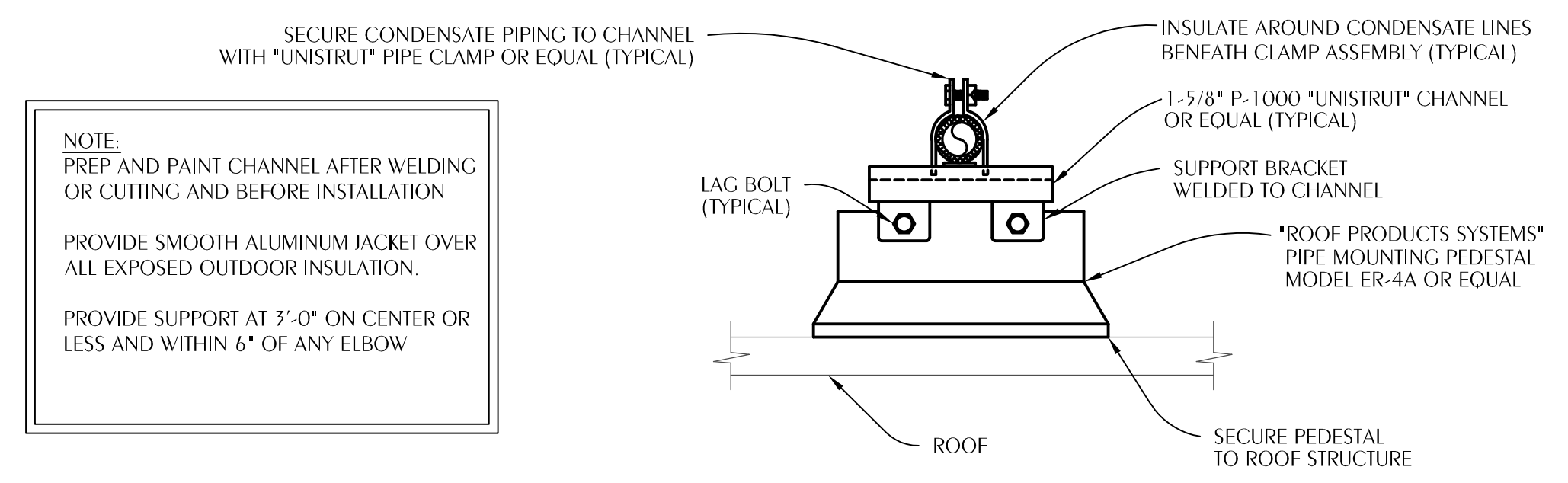

NOTE:
PREP AND PAINT CHANNEL AFTER WELDING OR CUTTING AND BEFORE INSTALLATION.
PROVIDE SMOOTH ALUMINUM JACKET OVER ALL EXPOSED OUTDOOR INSULATION.
PROVIDE SUPPORT AT 3'-0" ON CENTER OR LESS AND WITHIN 6" OF ANY ELBOW.

5 TYPICAL ROOFTOP CONDENSATE PIPE SUPPORT
M301 SCALE: NONE

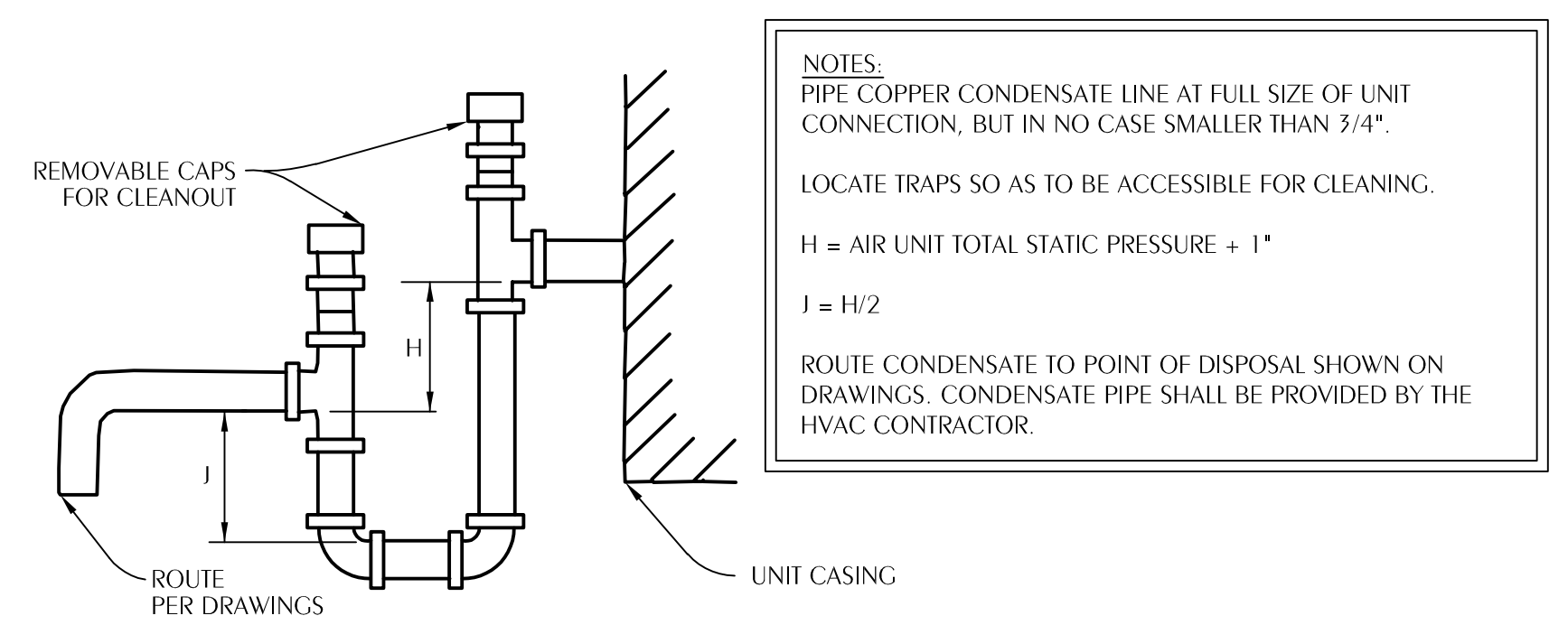

NOTES:
PIPE COPPER CONDENSATE LINE AT FULL SIZE OF UNIT CONNECTION, BUT IN NO CASE SMALLER THAN 3/4".
LOCATE TRAPS SO AS TO BE ACCESSIBLE FOR CLEANING.
 $H = \text{AIR UNIT TOTAL STATIC PRESSURE} + 1'$
 $J = H/2$
ROUTE CONDENSATE TO POINT OF DISPOSAL SHOWN ON DRAWINGS. CONDENSATE PIPE SHALL BE PROVIDED BY THE HVAC CONTRACTOR.

6 NEGATIVE PRESSURE CONDENSATE DRAIN TRAP
M301 SCALE: NONE

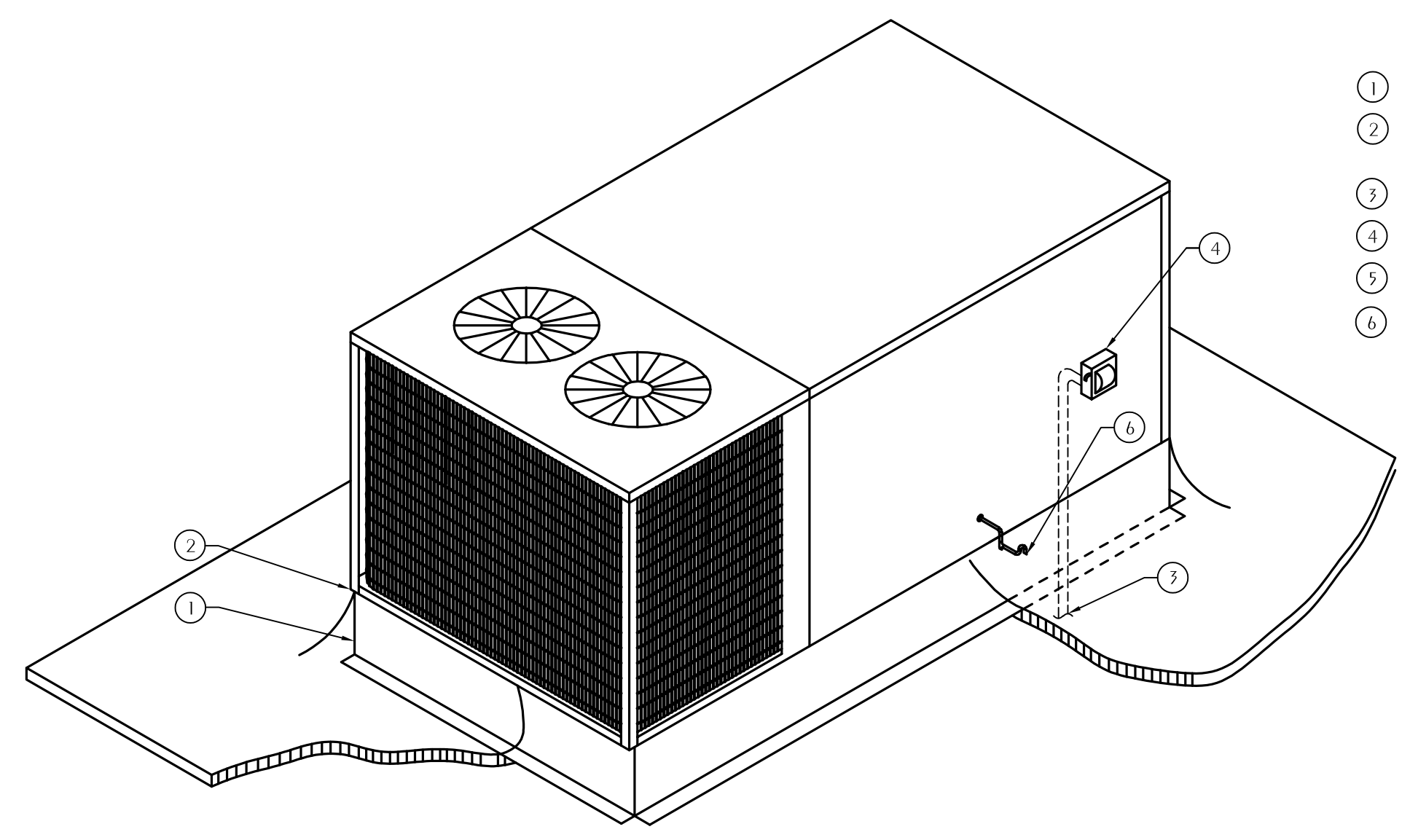

8 TYPICAL RTU INSTALLATION DETAIL
M301 SCALE: NONE

REVISIONS:

No.	Description	Date

MECHANICAL DETAILS

Project number	17057.5
Dated	JANUARY 2019
PC	DNW
PM	KAJ

M301

Scale NONE

Watford Engineering, Inc.
Mechanical Consulting
4471 Clinton Street
Maitland, FL 32747
Florida CA Number: 27825
Project Number: 2018-021

T: 850-526-3447
F: 850-526-3448
David N. Watford, PE
FL License Number: 38208

VERTICAL INSTALLATION

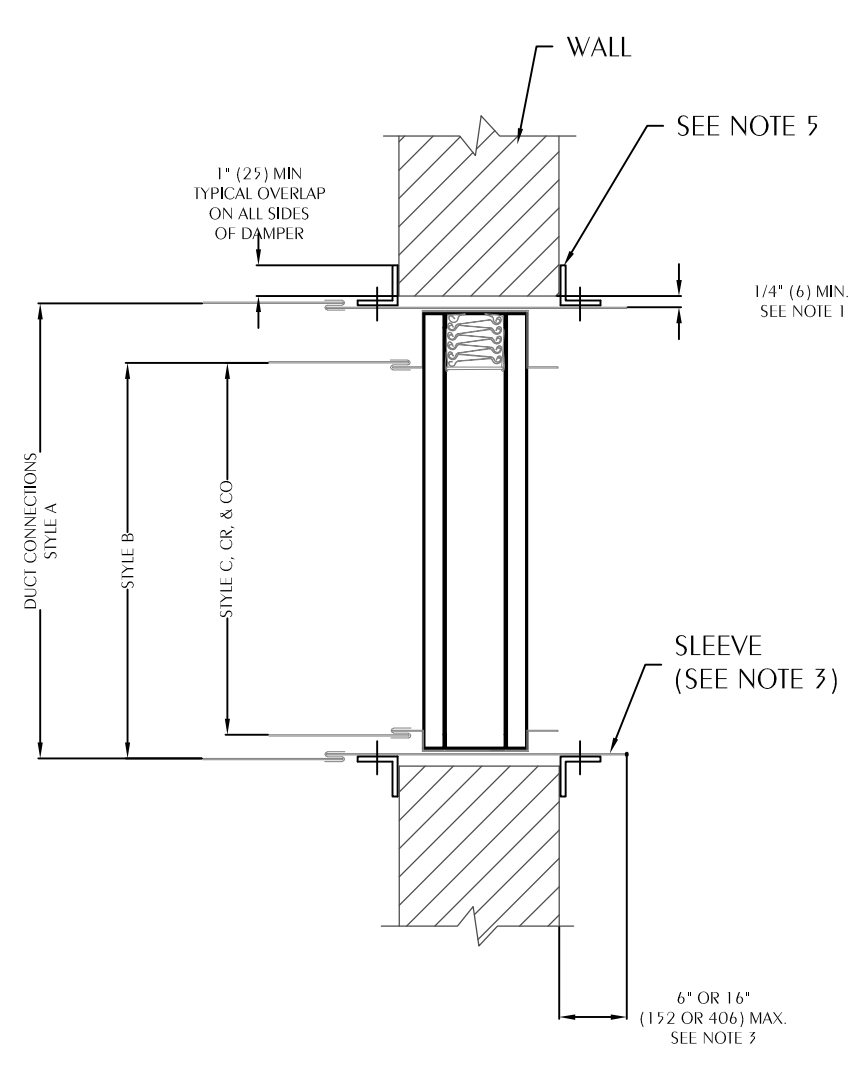

FIGURE 1

STAINLESS STEEL DAMPERS

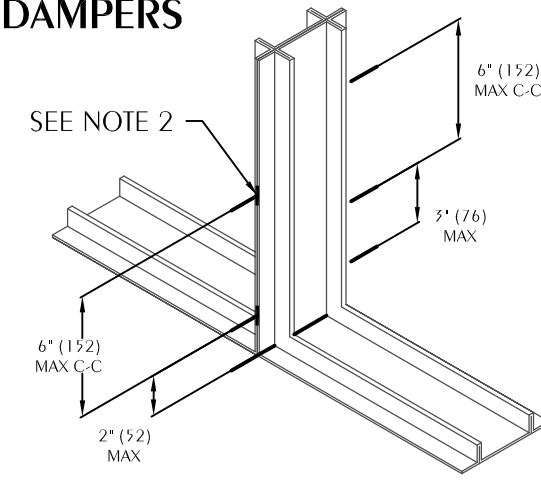

FIGURE 2

GALVANIZED DAMPERS

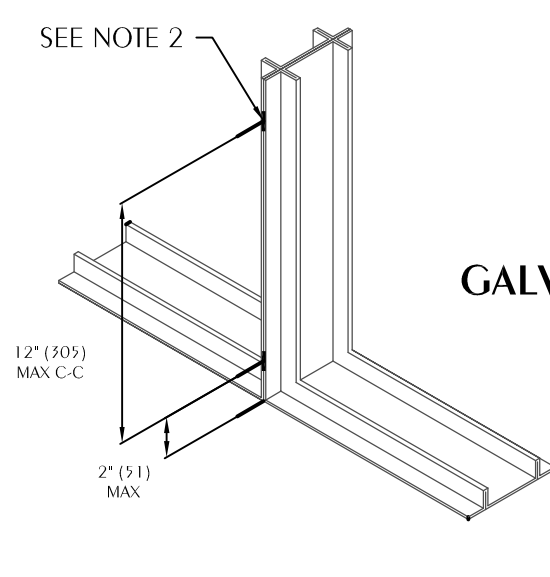

FIGURE 3

HORIZONTAL INSTALLATION

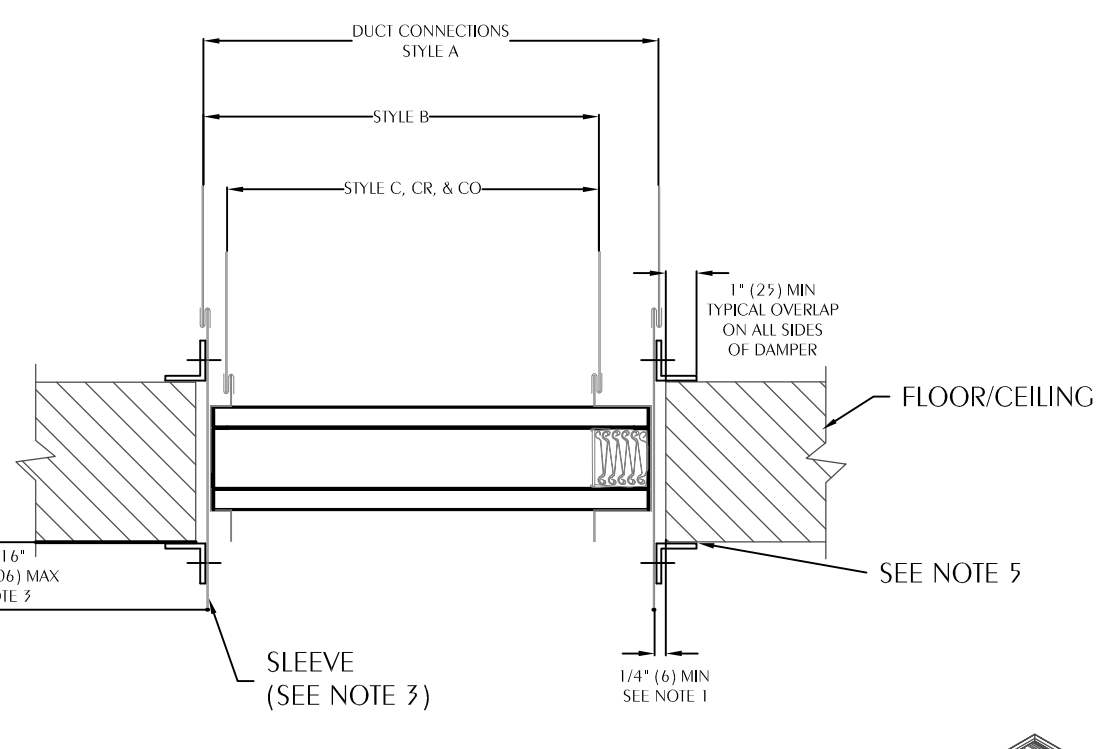

FIGURE 4

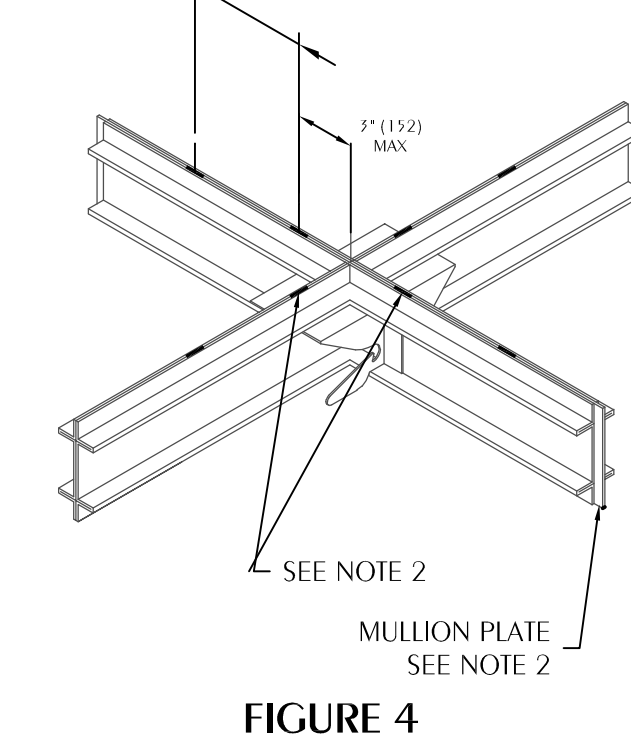

FIGURE 5

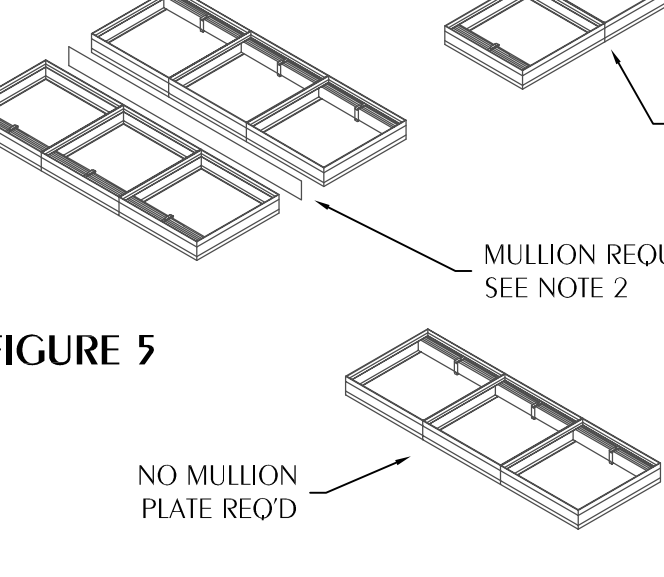

FIGURE 6

- Opening Clearance**
The opening in the wall or floor shall be larger than the damper/sleeve assembly to permit installation or expansion. For two angle installations the opening shall be a minimum of 1/8" per foot (3 per 305) larger than the overall size of the damper/sleeve assembly. The maximum opening size shall not exceed 1/8" per foot (3 per 305) plus 2" (51), nor shall the opening be less than 1 1/4" (6) larger than the damper/sleeve assembly. For one angle installation, the opening shall be a minimum of 1/4" (6) to a maximum of 1" (25) larger than the overall size of the damper/sleeve assembly. The opening may be as much as 2" (51) larger than the damper/sleeve assembly if a 1/8" (6) bevel is utilized.
- Fasteners and Multiple Section Assembly**
Use No. 10 (MS) bolts or screws, 3/16" (5) rivets, rack welds on spot welds as depicted in figures 3 and 4 and spaced as follows when joining individual dampers to make multiple section damper assemblies or when fastening damper to the sleeve:
Vertical Mount (In wall)
Galvanized steel dampers 12" (305) spacing
Stainless steel dampers 6" (152) spacing
Horizontal Mount (In floor)
All dampers 6" (152) spacing
Multiple section horizontal mount dampers require a 1/4" gage thick x 41/2" (2 x 114) wide steel reinforcing plate sandwiched between the damper flanges with 1/2" (13) long welds staggered alternately and spaced on maximum 6" (152) centers. The reinforcing plate must be the same material as the dampers. The length must be equal to the damper widths of two or more adjoining damper sections. Reinforcing plates are not required for assemblies consisting of two dampers attached end-to-end or three dampers attached side-to-side as depicted in figure 5.
- Damper Sleeve**
Sleeve thickness must be equal to or thicker than the duct connected to it. Sleeve gage requirements are listed in the SMACNA Fire, Smoke and Radiation Damper Installation Guide for HVAC Systems and in NFPA90A. If a breakaway style duct/sleeve connection is not used, the sleeve shall be a minimum of 16 gage (1.6) for dampers up to 36" (914) wide by 24" (610) high and 14 gage (1.9) for dampers exceeding 36" (914) wide by 24" (610) high. Damper sleeve shall not extend more than 6" (152) beyond the fire wall or partition unless damper is equipped with a factory installed access door. Sleeve may extend up to 16" (406) beyond the fire wall or partition on sides equipped with a factory installed access door. Sleeve shall terminate at both sides of wall within dimensions shown.
- Damper Orientation**
Use "Air Flow" and "Mount with Arrow Up" labels on Dynamic, DIBD and DIBDX models for proper damper orientation. For Static DIBD models use only "Mount with Arrow Up" label on damper for proper damper orientation.
- Mounting Angles**
Mounting angles shall be a minimum of 1 1/2" x 1 1/2" x 20 gage steel (58 x 58 x 1.0). For openings in metal stud, wood stud walls or concrete/masonry walls and floors of sizes 90" x 49" or 49" x 90" (2286 x 1245 or 1245 x 2286) and less mounting angles are only required on one side of the wall or top side of the floor and must be attached to both the sleeve and the wall or floor. Mounting angles may be installed directly to the metal stud under the wall board on stud wall installations only. Larger openings require mounting angles on both sides of the partition and must be attached only to the sleeve. Mounting angles must overlap the partition a minimum of 1" (25). Do not weld or fasten angles together at corners of dampers. Raskis fire dampers may be installed using Raskis FAST angle for one angle installation or Raskis PMA for two angle installations.
A. **Mounting Angle Fasteners**
Sleeve: #10 bolts or screws, 3/16" (5) steel rivets or 1/2" (13) long welds.

- Backaway Duct/Sleeve Connections**
Rectangular ducts must use one or more of the connections: plain "S" slip, flanged "S" slip, double "S" slip, inside slip joint, standing, S (angle reinforced), standing, S (bar reinforced), standing, S (angle reinforced), or duct slip joint.
A maximum of two #10 sheet metal screws on each side and the bottom, located in the center of the slip pocket and penetrating both sides of the slip pocket may be used. Connections using these slip joints on the top and bottom with flat duct slips up to 20" (508) long, on the sides may also be used.
- Round and Oval Break-away Connections**
Round and flat oval break-away connections must use either a 4" (102) wide doweled or #10 sheet metal screws spaced evenly around the circumference of the duct as follows:
• Duct diameters 22" (559) and smaller - Maximum 2 screws.
• Duct diameters over 22" (559) and including 36" (914) - Maximum 5 screws.
• Duct diameters over 36" (914) and up to and including 191" (4851) total perimeter - Maximum 8 screws. For flat oval ducts, the diameter is considered the largest (major) dimension of the duct.
NOTE: When optional sealing of these joints is desired, the following sealants may be applied in accordance with the sealant manufacturer's instructions:
Hardcoat, Inc. - Iso-Grip 601 Precision-PA208-4T
Eco Duct Seal 44-52 Design Polymers - DP 1010
- Flanged Break-away Style Duct Sleeve Connections**
Flanged connection systems manufactured by Ductmate, Nexus or Wood are approved break-away connections when installed as shown on the Flanged System Breakaway Connections Supplement. TDC and TDF roll-formed flanged connections using 3/8" (10) steel bolts and nuts, and metal cleats, as tested by SMACNA, are approved break-away connections when installed as shown on the Flanged System Breakaway Connections Supplement.
- Non-Break-away Duct/Sleeve Connections**
If other duct sleeve connections are used, the sleeve shall be a minimum of 16 gage (1.6) for dampers up to 36" (914) wide x 24" (610) high and 14 gage (2.0) for dampers exceeding 36" (914) wide x 24" (610) high.
- Installation and Maintenance**
To ensure optimum operation and performance, the damper must be installed so it is square and free from backing. Each fire damper should be maintained and tested on a regular basis and in accordance with the latest editions of NFPA 90A and local codes. Care should be exercised to ensure that such tests are performed safely and do not cause system damage.

2 TYPICAL FIRE RATED WALL PENETRATION
SCALE: NONE BARE METALLIC PIPE

- FLOOR OR WALL ASSEMBLY**—MIN 2-1/2 IN. THICK REINFORCED LIGHTWEIGHT OR NORMAL WEIGHT (100-150) PCF CONCRETE. WALL MAY ALSO BE CONSTRUCTED OF ANY UL CLASSIFIED CONCRETE BLOCKS* MAX DIAM OF OPENING IS 18 IN. SEE CONCRETE BLOCKS (CAZT) CATEGORY IN THE FIRE RESISTANCE DIRECTORY FOR NAMES OF MANUFACTURERS.
- STEEL SLEEVE**—NOM 10 IN. (OR SMALLER) SCHEDULE 10 (OR HEAVIER) STEEL SLEEVE CAST OR GROUTED INTO FLOOR OR WALL ASSEMBLY. SLEEVE MAY EXTEND A MAX OF 2 IN. ABOVE TOP OF FLOOR OR BEYOND EITHER SURFACE OF WALL. F RATING IS 0 HR WHEN SLEEVE IS USED.
- THROUGH-PENETRANT**—NOM 4 IN. DIAM (OR SMALLER) TYPE 1 (OR HEAVIER) COPPER PIPE, NOM 12 IN. DIAM (OR SMALLER) SERVICE WEIGHT (OR HEAVIER) CAST IRON SOIL PIPE, NOM 12 IN. DIAM (OR SMALLER) CLASS 50 (OR HEAVIER) DUCTILE IRON PRESSURE PIPE, OR NOM 12 IN. DIAM (OR SMALLER) SCHEDULE 10 (OR HEAVIER) STEEL PIPE CENTERED IN THE OPENING AND RIGIDLY SUPPORTED ON BOTH SIDES OF THE FLOOR OR WALL ASSEMBLY.
- PIPE COVERING**—NOM 1/2 TO 2 IN. THICK HOLLOW CYLINDRICAL HEAVY DENSITY (MIN. 3.5 PCF) GLASS FIBER UNITS JACKED ON THE OUTSIDE WITH AN ALL SERVICE JACKET. LONGITUDINAL JOINTS SEALED WITH METAL FASTENERS OR FACTORY-APPLIED SELF-SEALING LAP TAPE. TRANSVERSE JOINTS SEALED WITH METAL FASTENERS OR WITH BUTT STRIP TAPE SUPPLIED WITH THE PRODUCT. SEE PIPE AND EQUIPMENT COVERING—MATERIALS (BRCU) CATEGORY IN BUILDING MATERIALS DIRECTORY FOR NAMES OF MANUFACTURERS. ANY PIPE COVERING MATERIAL MEETING THE ABOVE SPECIFICATIONS AND BEARING THE UL CLASSIFICATION MARKING WITH A FLAME SPREAD INDEX OF 25 OR LESS AND A SMOKE DEVELOPED INDEX OF 50 OR LESS MAY BE USED.
- FIRESTOP SYSTEM**—THE DETAILS OF THE FIRESTOP SYSTEM SHALL BE AS FOLLOWS:
A. **PACKING MATERIAL**—MIN 1 IN. THICKNESS OF FIRMLY PACKED MINERAL WOOL BATT INSULATION USED AS A PERMANENT FORM. PACKING MATERIAL TO BE RECESSED FROM TOP SURFACE OF FLOOR OR SLEEVE OR FROM BOTH SURFACES OF WALL AS REQUIRED TO ACCOMMODATE THE REQUIRED THICKNESS OF CAULK FILL MATERIAL (ITEM B).
B. **FILL, VOID OR CAVITY MATERIAL**—CAULK—APPLIED TO FILL THE ANNULAR SPACE FLUSH WITH THE TOP SURFACE OF THE FLOOR OR SLEEVE OR FLUSH WITH BOTH SURFACES OF WALL WHEN NOM PIPE COVERING THICKNESS IS 2 IN. MIN THICKNESS OF CAULK FILL MATERIAL IS 2 IN. WHEN NOM PIPE COVERING THICKNESS IS 1-1/2 IN. OR LESS, MIN THICKNESS OF CAULK FILL MATERIAL IS 1 IN. THE HOURLY F AND I RATINGS OF THE FIRESTOP SYSTEM ARE DEPENDENT UPON THE THICKNESS OF THE FLOOR OR WALL, THE SIZE OF PIPE, THE THICKNESS OF PIPE COVERING MATERIAL AND THE SIZE OF THE ANNULAR SPACE BETWEEN THE PIPE COVERING MATERIAL AND THE EDGE OF THE CIRCULAR THROUGH OPENING, AS SHOWN IN THE FOLLOWING TABLE:
MIN FLOOR OR WALL THICKS MAX PIPE DIAM NOM PIPE COVERING THICKS ANNULAR SPACE F RATING I RATING

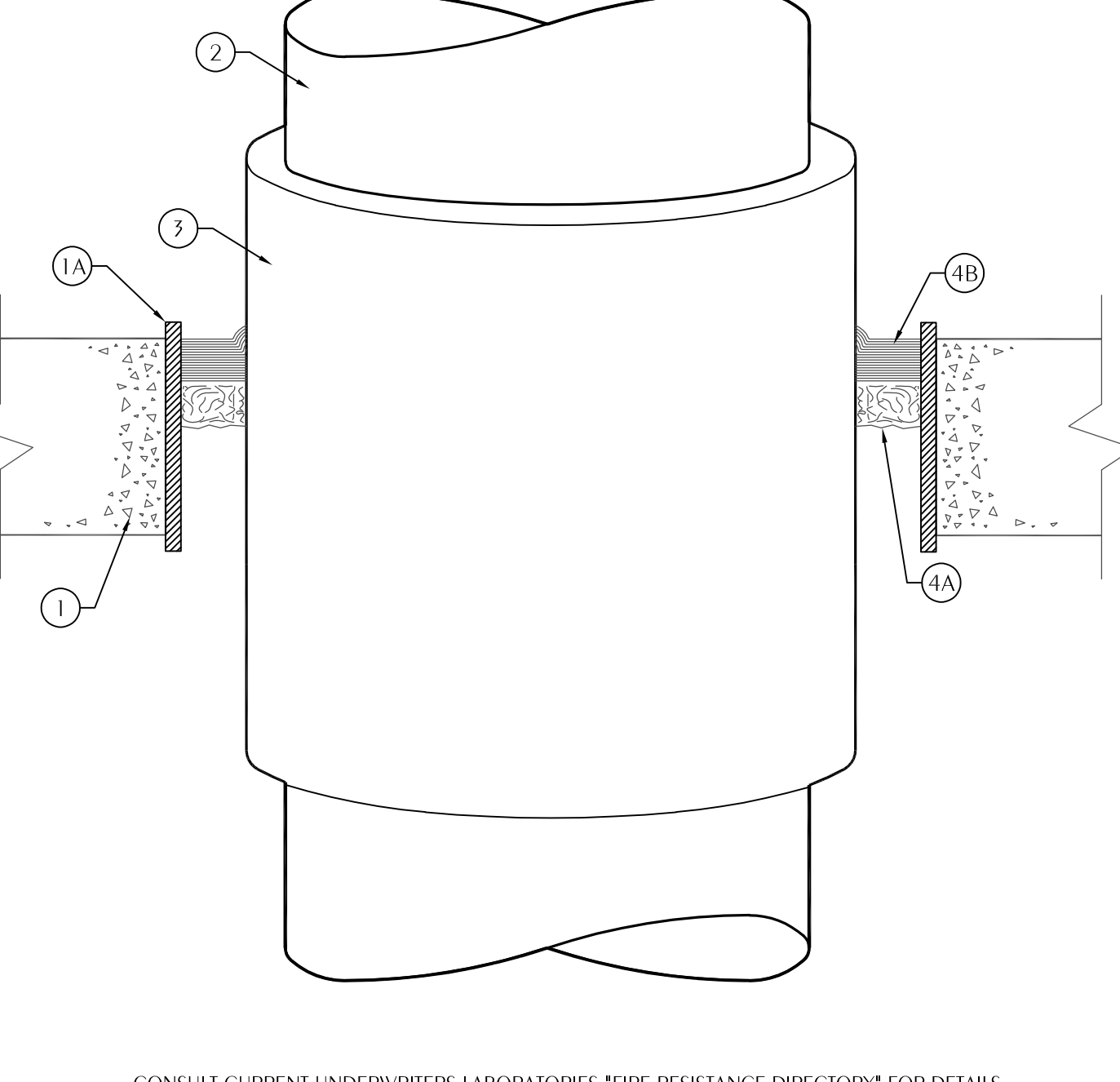

CONSULT CURRENT UNDERWRITERS LABORATORIES "FIRE RESISTANCE DIRECTORY" FOR DETAILS

UL SYSTEM CA15001

4 TYPICAL FIRE RATED WALL/FLOOR PENETRATION
SCALE: NONE FIBERGLASS INSULATED METALLIC PIPE

HR	IN.	IN.	IN.	IN.	HR
2-1/2	4	1 OR 1-1/2	1/2 TO 2-3/8	2	1
4-1/2	4	2	1/4 TO 3-5/8	2	1-1/2
2-1/2	12	1	1/2 TO 1-1/2	2	1/2
4-1/2	12	1	1/2 TO 2-3/8	3	1
2-1/2	12	1/2	1/2 TO 2-3/8	2	0

MINNESOTA MINING & MFG. CO.—CP 25WB+
*BEARING THE UL CLASSIFICATION MARKING

NOTE: ALL SYSTEMS DETAILED ON MECHANICAL PENETRATIONS SHEETS ARE BASED ON THE MANUFACTURERS SPECIFIED AS BASIS OF DESIGN AND APPLY TO MECHANICAL, FIRE PROTECTION, AND PLUMBING. THE CONTRACTOR SHALL SUBMIT A PENETRATIONS PACKAGE DETAILING EACH PENETRATION AND PRODUCTS TO BE USED TO THE PERMITTING AUTHORITY FOR THE ACTUAL SYSTEMS TO BE USED.

3 TYPICAL FIRE RATED WALL PENETRATION
SCALE: NONE BARE PLASTIC PIPE 2" DIAMETER OR SMALLER

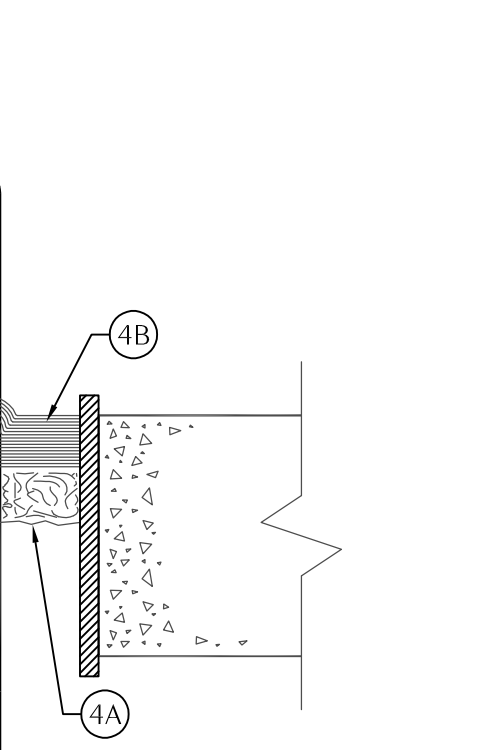

CONSULT CURRENT UNDERWRITERS LABORATORIES "FIRE RESISTANCE DIRECTORY" FOR DETAILS

1 TYPICAL HORIZONTAL AND VERTICAL FIRE DAMPER DETAIL
SCALE: NONE



MEMBERSHIP OF SERVICES
ALL REPORTS, PLANS, SPECIFICATIONS, COMPUTER FILES, FIELD DATA, NOTES AND OTHER DOCUMENTS ARE THE PROPERTY OF LAG. THE CONSULTANT SHALL REMAIN THE PROPERTY OF THE CONSULTANT. THE CONSULTANT SHALL RETAIN ALL COMMON LAW, STATUTORY AND OTHER RESERVED RIGHTS, INCLUDING THE COPYRIGHT THEREIN.

PURSUANT TO FLORIDA STATUTES, SECTION 690.005, AN INDIVIDUAL EMPLOYEE OR AGENT MAY NOT BE HELD INDIVIDUALLY LIABLE FOR NEGLIGENCE.

BID DOCUMENTS

EMERALD COAST CONVENTION CENTER
RESTROOM RENOVATIONS & MEETING ROOM
COUNTERS
TASK ORDER NO. 5 - C-18-2638-TDD
1250 MIRACLE STRIP PKWY SE
FORT WALTON BEACH, FL 32548

REVISIONS:

No.	Description	Date

MECHANICAL DETAILS

Project number	17057.5
Dated	JANUARY 2019
PMC	DNW
PM	KAJ

M302

Scale NONE

Watford Engineering, Inc.
Mechanical Consulting
4471 Clinton Street
Marlinton, FL 32446
Florida CA Number: 27825
Project Number: 2018-021
T: 850-526-3447
F: 850-526-5448
David N. Watford, PE
FL License Number: 38088

ELECTRICAL LEGEND

- A-1 ADJACENT TO ARROW INDICATES HOMERUN OF CIRCUIT NO. 1 TO PANEL A; "B" INDICATES FIXTURE TYPE; MARKS ACROSS RACEWAY RUN INDICATES THE NUMBER OF NO. 12 CONDUCTORS; UNLESS NOTED OTHERWISE NO MARKS INDICATES TWO NO. 12 CONDUCTORS AND ONE NO. 12 GREEN GROUND CONDUCTOR IN 1/2" CONDUIT (2#12 & 1#12 GND-1/2"C)
- CEILING FIXTURE
 - CEILING FIXTURE ON EMERGENCY CIRCUIT
 - 1' x 4' CEILING MOUNTED FIXTURE
 - ⊗ EXIT SIGN; CEILING MOUNTED; ARROWS AS NOTED; SHADED SECTION INDICATES LIGHTED FACE OF EXIT SIGN
 - ⊖ JUNCTION BOX; MOUNTED ABOVE CEILING
 - ⊖ JUNCTION BOX; MOUNTED FLUSH IN WALL WITH BLANK COVER
 - ⊖ DUPLEX RECEPTACLE; 125V; 20A; 3 POLE GND; MT 18" AFF TO C/L UNLESS NOTED OTHERWISE; NEMA 5-20R; HUBBELL SERIES HBL5352
 - ⊖ QUAD RECEPTACLE; 125V; 20A; 3 POLE GND; MOUNT ABOVE COUNTER; NEMA 5-20R; HUBBELL SERIES HBL5352
 - ⊖ DUPLEX RECEPTACLE; 125V; 20A; 3 POLE GND; GF; INSTALL NEW RECEPTACLE & PLATE IN EXISTING OUTLET BOX FOR DRINKING FOUNTAIN; NEMA 5-20R; HUBBELL SERIES GF5362
 - ⊖ WALL SWITCH; 120/277V; 20A; VACANCY SENSOR DUAL TECHNOLOGY MULTI-WAY TYPE; MT 48" AFF TO C/L; REFER TO SPECS
 - ⊖ LOW VOLTAGE WALL SWITCH; MT. 48" AFF TO C/L; REFER TO SPECS; SEE LIGHTING CONTROL DETAILS
 - PANEL; 120/208V
 - ⊖ EXHAUST FAN; FURNISHED BY OTHERS
 - ⊖ MAGNETIC STARTER; FURNISHED BY OTHERS
 - ⊖ FUSED DISCONNECT SWITCH; AMP SIZE AS NOTED; FUSE SIZE PER EQUIPMENT NAMEPLATE DATA
 - RACEWAY INSTALLED CONCEALED IN WALLS AND/OR ABOVE CEILING
 - EXISTING RACEWAY INSTALLED CONCEALED ABOVE CEILING
 - ~ FLEXIBLE CONDUIT CONNECTION
 - ⊖ NORMAL/EMERGENCY LIGHTING SWITCHING RELAY; MOUNT ABOVE CEILING
 - ⊖ VACANCY SENSOR POWER PACK; MOUNT ABOVE CEILING
 - ⊖ LOW VOLTAGE VACANCY SENSOR; 360° DUAL-TECHNOLOGY TYPE; CEILING MOUNTED

REPLACEMENT PANEL

PANELBOARD		VOLTAGE: 208Y/120V	PHASE: 3φ	WIRE: 4	MOUNTING: SURFACE				
PA		MAINS: 250A MB	AIC RATING: 10,000 MINIMUM						
		NEMA RATING: 1	OPTIONS: BOLT-ON BREAKERS; SINGLE SECTION						
CKT NO.	SERVING	CONN LOAD	CKT TRIP	BKR POLE	CKT BKR POLE	TRIP	CONN LOAD	SERVING	CKT NO.
1	RTU-1 ROOFTOP PACKAGE UNIT	8986	60	2	2	60	8986	RTU-2 ROOFTOP PACKAGE UNIT	2
3	---	---	---	---	---	---	---	---	6
5	RTU-3 ROOFTOP PACKAGE UNIT	8986	60	2	2	---	---	SPACE ONLY	8
7	---	---	---	---	---	---	---	---	10
9	RESTROOM #1 POWER SUPPLY/CONVERTER	1620	20	1	1	20	1620	RESTROOM #2 POWER SUPPLY/CONVERTER	12
11	RESTROOM #1 POWER SUPPLY/CONVERTER	1620	20	1	1	20	1620	RESTROOM #2 POWER SUPPLY/CONVERTER	14
13	RESTROOM #1 LIGHTED MIRRORS	810	20	1	1	20	810	RESTROOM #2 LIGHTED MIRRORS	16
15	RESTROOM #3 POWER SUPPLY/CONVERTER	1620	20	1	1	20	1620	RESTROOM #4 POWER SUPPLY/CONVERTER	18
17	RESTROOM #3 POWER SUPPLY/CONVERTER	1620	20	1	1	20	1620	RESTROOM #4 POWER SUPPLY/CONVERTER	20
19	RESTROOM #3 LIGHTED MIRRORS	810	20	1	1	20	810	RESTROOM #4 LIGHTED MIRRORS	22
21	RESTROOM #5 POWER SUPPLY/CONVERTER	1620	20	1	1	20	1620	RESTROOM #6 POWER SUPPLY/CONVERTER	24
23	RESTROOM #5 POWER SUPPLY/CONVERTER	1620	20	1	1	20	1620	RESTROOM #6 POWER SUPPLY/CONVERTER	26
25	RESTROOM #5 LIGHTED MIRRORS	810	20	1	1	20	810	RESTROOM #6 LIGHTED MIRRORS	28
27	RECEPT - PREFUNCTION 201C	1080	20	1	1	20	900	RECEPT - PREFUNCTION 201B	30
29	RECEPT - PREFUNCTION 201A	900	20	1	1	20	540	RECEPT - CORRIDOR EAST	32
31	DUPLEX OUTLET	500	20	1	1	20	1000	COPPER OUTLET	34
33	DUPLEX OUTLET	500	20	1	1	20	1000	MECH ROOM DUPLEX OUTLET	36
35	DUPLEX OUTLET	500	20	1	3	50	10000	PANEL PAJ	38
37	DUPLEX OUTLET	500	20	1	---	---	---	---	40
39	DUPLEX OUTLET	500	20	1	---	---	---	---	42
41	DUPLEX OUTLET	500	20	1	1	20	500	FAN EF4	44
43	DUPLEX OUTLET	500	20	1	1	20	500	FAN SF8	46
45	DUPLEX OUTLET	500	20	1	1	20	500	FAN EF5	48
47	DUPLEX OUTLET	500	20	1	1	20	500	FAN EF8	50
49	W. COOLER AT SW TOILET	500	20	1	1	20	500	FOUNTAIN LIGHTS	52
51	CASHER OUTLETS	500	20	1	1	20	500	FAN EF3	54
53	W. COOLER LOBBY TOILET	500	20	1	1	20	500	GENERAL MANAGER RECEPT	56
55	LOBBY & SW TOILET RECEPT	500	20	1	1	20	500	CONFERENCE RECEPT	58
57	AUTO DOOR OP. @ 201K & 200A	500	20	1	1	20	500	COMPTROLLER RECEPT	60
59	ROOF RECEPT	500	20	1	1	20	500	ATM RECEPT	62
61	ELEC ROOM RECEPT	500	20	1	1	20	500	EMPLOYEE LOUNGE	64
63	AUTOMATIC DOOR	500	20	1	1	20	500	TIME CLOCK FOUNTAIN LIGHTS	66
65	FOUNTAIN PUMP	500	20	1	1	20	500	TOWER OBSTRUCTION LIGHTS	68
67	FOUNTAIN PUMP	500	20	1	1	20	500	VENDING	70
69	VENDING	500	20	1	1	20	500	VENDING	72
71	VENDING	500	20	1	1	20	500	FOUNTAIN LIGHTS	74
73	SPACE ONLY	---	---	1	1	---	---	SPACE ONLY	76
75	SPACE ONLY	---	---	1	3	30	---	---	78
77	SPACE ONLY	---	---	2	---	---	---	---	80
79	---	---	---	---	---	---	---	---	---
TOTAL CONNECTED LOAD:		84,548	/	360		235	TOTAL AMPS		
TOTAL DEMAND LOAD (N.E.C. 220.44)		75,048	/	360		208	TOTAL AMPS		

PANEL PA - GENERAL NOTE
 REPLACE EXISTING PANEL PA WITH NEW PANEL PA. NEW PANEL TO BE SINGLE SECTION, MINIMUM OF 80 BREAKER SPACES, 250 AMP MAIN BREAKER; FIELD VERIFY EXISTING BREAKERS AND ELECTRICAL REQUIREMENTS. RECONNECT ALL EXISTING CIRCUITS TO NEW PANEL.

MECHANICAL EQUIPMENT CIRCUIT DESIGN SCHEDULE

(VERIFY ALL EQUIPMENT CIRCUIT REQUIREMENTS WITH MANUFACTURERS SHOP DRAWINGS PRIOR TO ROUGH-IN)

EQUIPMENT DESIGNATION	DESCRIPTION	VOLTAGE	MINIMUM CIRCUIT CAPACITY	MAXIMUM CIRCUIT OVERCURRENT PROTECTION	PROTECTION SPECIFIED	HEATER KW	FAN HP	CFM	REMARKS
RTU-1	ROOFTOP PACKAGE UNIT	208V 1φ	54 AMPS	60 AMPS	60/2	7.5	1/3	1025	NONE
RTU-2	ROOFTOP PACKAGE UNIT	208V 1φ	54 AMPS	60 AMPS	60/2	7.5	1/3	880	NONE
RTU-3	ROOFTOP PACKAGE UNIT	208V 1φ	54 AMPS	60 AMPS	60/2	7.5	1/3	975	NONE
EWC-1	ELECTRIC WATER COOLER	115V	4 AMPS	20 AMPS	20/1	--	--	---	NONE

LIGHTING FIXTURE SCHEDULE

TYPE	MANUFACTURER	CATALOG NUMBER	LAMPS		MOUNTING	DESCRIPTION	FIXTURE EQUALS
			NO.	TYPE			
'DL'	PRESCOLITE	LO6LED120-6LC LED740KBWH-IWT	25	LED 4000K 80CRI	CEILING RECESSED	6" DIA x 5 3/4" H DOWNLIGHT, OPEN WHITE REFLECTOR, WITH WHITE SELF TRIM, 1800 LUMENS, 120V	OR APPROVED EQUAL
'DLE'	PRESCOLITE	LO6LED120M6LCLED 740KBWH-IWTM	25	LED 4000K 80CRI	CEILING RECESSED	6" DIA x 5 3/4" H DOWNLIGHT, OPEN WHITE REFLECTOR, WITH WHITE SELF TRIM, 1800 LUMENS, BATTERY PACK WITH INTEGRAL TEST SWITCH AND INDICATOR LIGHT, 120V	OR APPROVED EQUAL
'VL'	LUMEN TRUSS	B3256-120V-HW-4000K-90-15B'-4WFT-350LM/FT	64W	LED 4000K 90CRI	INSTALL BELOW VANITY	15'-8" LONG CHANNEL (1450 PROFILE CHANNEL) MOUNTED UNDER VANITY TAPE LIGHT FIXTURE. PROVIDE ALL NECESSARY ACCESSORIES FOR A COMPLETE INSTALLATION, 120V.	OR APPROVED EQUAL
'X'	CHLORIDE	ER45VXL-1-RC (ARROWS AS NOTED)	---	LED ARRAY	CEILING SURFACE	CEILING MOUNTED SINGLE FACE EXIT SIGN, RED LETTERS, CLEAR ACRYLIC LETTER PANEL, 277V. NICKEL-CADMIUM MAINT. FREE BATTERY, TEST SWITCH & READY LIGHT	QUALI-LITE, EMERGLITE OR SURE-LITE

ELECTRICAL GENERAL NOTES

- A. CONTRACTOR SHALL COORDINATE ALL WORK WITH OTHER TRADES PRIOR TO INSTALLATION. REFER TO MECHANICAL AND PLUMBING DRAWINGS FOR EXACT SIZE AND LOCATION OF EQUIPMENT WHICH IS FURNISHED BY OTHERS AND CONNECTED BY ELECTRICAL.
- B. RECEPTACLES, SWITCHES AND COVERPLATES COLOR SHALL BE SELECTED BY THE ARCHITECT FROM STANDARD COLORS.
- C. VERIFY ALL DOOR SWINGS WITH ARCHITECTURAL DRAWINGS PRIOR TO ROUGH-IN WALL FOR SWITCHES.
- D. FINAL CONNECTION TO ALL MOTORS SHALL BE WITH FLEXIBLE CONDUIT CONNECTION.
- E. ALL EXIT AND EMERGENCY FIXTURES SHALL BE CONNECTED TO LIGHT CIRCUIT AHEAD OF LOCAL SWITCH.
- F. ALL PANELBOARDS, BACKBOARDS, TERMINAL CABINETS, ETC SHALL HAVE CUSTOM ENGRAVED MICARTA NAMEPLATE MECHANICALLY AFFIXED IDENTIFYING SYSTEM.
- G. PROVIDE GREEN GROUND CONDUCTOR IN ALL CIRCUITS - SIZE PER N.E.C.
- H. ALL EXPOSED CONDUITS, BOXES, STRAPS AND HANGERS IN THE CONTRACT AREA WHETHER NEW OR EXISTING THAT ARE PART OF THE ELECTRICAL SYSTEM SHALL BE PAINTED TO MATCH ADJACENT FINISH.
- I. GENERAL CONTRACTOR SHALL FIELD-VERIFY ALL EXISTING CONDITIONS PRIOR TO BEGINNING ANY WORK, AND SHALL IMMEDIATELY NOTIFY THE ARCHITECT OF ANY DISCREPANCIES. FAILURE TO DO SO INDICATES THAT THE CONTRACTOR ACCEPTS THE CONDITIONS AS THEY EXIST, AND SHALL PERFORM THE WORK REQUIRED AS SHOWN AND SPECIFIED.
- J. THE ELECTRICAL CONTRACTOR SHALL OBTAIN AND REVIEW THE MECHANICAL AND SPECIAL EQUIPMENT SUBMITTALS PRIOR TO SUBMITTING THE ELECTRICAL SUBMITTALS. ANY ELECTRICAL EQUIPMENT, CONDUIT, AND WIRE SIZE CHANGES RESULTING FROM THIS REVIEW SHALL ALSO BE SUBMITTED FOR APPROVAL.
- K. THE ELECTRICAL CONTRACTOR SHALL PROVIDE FAULT CURRENT CALCULATIONS FOR THE SERVICE EQUIPMENT AND SHALL MARK THE EQUIPMENT WITH THE AVAILABLE FAULT CURRENT AND DATE OF THE CALCULATION PER NEC 110.24. REFER TO TYPICAL SERVICE EQUIPMENT FAULT CURRENT LABEL DETAIL.
- L. THE ELECTRICAL CONTRACTOR SHALL PROVIDE ARC FAULT LABELS PER NFPA 70E ARTICLE 110.16 FOR NEW EQUIPMENT. THE OWNER SHALL PROVIDE AVAILABLE CALCULATION DATA FOR THE EXISTING EQUIPMENT IN THE ELECTRICAL SYSTEM. REFER TO TYPICAL ARC FLASH HAZARD LABEL DETAIL.
- M. PROVIDE NEUTRAL AT ALL LINE VOLTAGE SWITCH LOCATIONS PER N.E.C. 404.2(C).
- N. OBTAIN ARCHITECTS APPROVAL OF ALL LIGHT FIXTURES, SWITCHES, RECEPTACLES, PANELBOARDS, ETC. PRIOR TO PURCHASING.
- O. THE ELECTRICAL WORK SHALL BE INSTALLED IN A NEAT AND WORKMANLIKE MANNER. ALL NOT SO INSTALLED SHALL BE REMOVED AND REPLACED AT NO COST TO THE OWNER.
- P. ALL WORK SHALL BE INSTALLED IN CONCEALED TYPE CONSTRUCTION. UNDERGROUND CONDUITS UP TO FIRST BOX IN CONCEALED CONSTRUCTION MAY BE SCH.40 PVC. BRANCH CIRCUIT CONDUIT RUN IN OPEN SPACES ABOVE CEILING OR IN WALLS MAY BE THINWALL (E.M.T.) CONDUIT 1/2" MIN SIZE.
- Q. ALL CONDUCTORS LESS THAN 100A, SHALL BE COPPER #12 & #10 SOLID, #8 AND LARGER STRANDED, #6 AND SMALLER TO BE TYPE THW, 600 VOLT INSULATION AND TYPE THW OR THHN FOR #4 AND LARGER. ALUM. CONDUCTORS MAY BE USED FOR 100A. AND LARGER ONLY WHERE USED WITH COMPRESSION TERMINATIONS.
- R. PROVIDE GROUNDING PER NATIONAL ELECTRIC CODE.
- S. THE CONTRACTOR SHALL LEAVE THE ENTIRE ELECTRICAL SYSTEM INSTALLED IN PROPER WORKING ORDER, AND SHALL REPLACE WITHOUT ADDITIONAL COST, ALL WORK OR MATERIAL WHICH MAY DEVELOP DEFECTS, (ORDINARY WEAR AND TEAR OR DAMAGE RESULTING FROM IMPROPER HANDLING EXCEPTED) WITHIN A PERIOD OF ONE (1) YEAR FROM THE DATE OF FINAL ACCEPTANCE BY THE OWNER.

SPECIAL DEMOLITION NOTE
 THE LOCATIONS OF ALL ELECTRICAL EQUIPMENT INDICATED (FIXTURES & DEVICES) MAY VARY FROM DRAWING. EXISTING CONDITIONS AND DEMOLITION WORK WAS DETERMINED BY SITE OBSERVATION AND REVIEW OF EXISTING DOCUMENTS WITHOUT THE BENEFIT OF DESTRUCTIVE INVESTIGATION. VERIFY ACTUAL LOCATIONS, TYPES, AND QUANTITIES OF EQUIPMENT AND APPLY DEMOLITION NOTES AS APPROPRIATE FOR THE EQUIPMENT AND ROOM OR AREA.

ELECTRICAL DEMOLITION NOTES

- I. CONTRACTOR SHALL COORDINATE ALL DEMOLITION WORK WITH OTHER TRADES PRIOR TO BEGINNING WORK. REFER TO MECHANICAL AND PLUMBING DRAWINGS FOR SCOPE AND LOCATION OF EQUIPMENT WHICH IS TO BE REMOVED BY OTHERS BUT THE CONNECTION REMOVED BY ELECTRICAL.
- II. GENERAL CONTRACTOR SHALL FIELD VERIFY ALL EXISTING CONDITIONS PRIOR TO BEGINNING ANY WORK, AND SHALL IMMEDIATELY NOTIFY THE ARCHITECT OF ANY DISCREPANCIES. FAILURE TO DO SO INDICATES THAT THE CONTRACTOR ACCEPTS THE CONDITIONS AS THEY EXIST, AND SHALL PERFORM THE WORK REQUIRED AS SHOWN AND SPECIFIED.
- III. ITEMS SHOWN ON THE ELECTRICAL DEMOLITION PLANS ARE TO BE REMOVED UNLESS INDICATED OTHERWISE. ITEMS SHOWN DO NOT REPRESENT ALL COMPONENTS OF DEMOLITION BUT ARE FOR DEMOLITION CLARITY. WHERE AN ITEM IS BEING REMOVED AND NOT REPLACED, ITS ASSOCIATED FEEDER CONDUIT AND WIRING SHALL BE REMOVED ALSO. WHERE A DEVICE IS BEING REMOVED AND REPLACED, ITS FEEDER CONDUIT MAY BE REUSED IF APPLICABLE.
- IV. WHEN A DEVICE IS TO BE REMOVED AND ITS CONTINUING CIRCUIT FEEDS OTHER LOADS, THE CONDUCTORS SHALL BE MADE CONTINUOUS TO THE REMAINING LOADS. NO CIRCUIT CONTINUITY SHALL BE LOST.
- V. REMOVE ALL ELECTRICAL CONNECTIONS, CONDUITS, WIRING, DISCONNECT SWITCHES, STARTERS, RELAYS, ETC. ASSOCIATED WITH THE MECHANICAL EQUIPMENT BEING REMOVED BY THE MECHANICAL CONTRACTOR.
- VI. IN THE EXISTING FLOOR AND WALLS TO REMAIN, FILL, PATCH, AND REPAIR HOLES AND PENETRATIONS CREATED BY EXISTING SYSTEMS EQUIPMENT REMOVAL.

Sheet List Table

Sheet Number	Sheet Title
E100	ELECTRICAL LEGEND & NOTES
E-200	ELECTRICAL NEW WORK - RESTROOMS
E-300	PARTIAL PLAN - ELECTRICAL NEW WORK - MEETING ROOMS
ED-200	ELECTRICAL DEMOLITION - RESTROOMS



dag ARCHITECTS INC.
 1225 AIRPORT ROAD - DESTIN, FLORIDA 32541
 TELEPHONE: 850-837-8152
 AA-C000745

OWNERSHIP OF INSTRUMENTS OF SERVICE
 ALL REPORTS, PLANS, SPECIFICATIONS, COMPUTER FILES, FIELD DATA NOTES AND OTHER DOCUMENTS AND INSTRUMENTS PREPARED BY THE CONSULTANT OR INSTRUMENTS OF SERVICE SHALL REMAIN THE PROPERTY OF THE CONSULTANT. THE CONSULTANT SHALL RETAIN ALL COMMON LAW, STATUTORY AND OTHER RESERVED RIGHTS, INCLUDING THE COPYRIGHT THEREIN.

BID DOCUMENTS

**EMERALD COAST CONVENTION CENTER
 RESTROOM RENOVATIONS & MEETING ROOM
 COUNTERS**
 TASK ORDER NO. 5 - C-18-2638-TDD
 1250 MIRACLE STRIP PKWY SE
 FORT WALTON BEACH, FL 32548

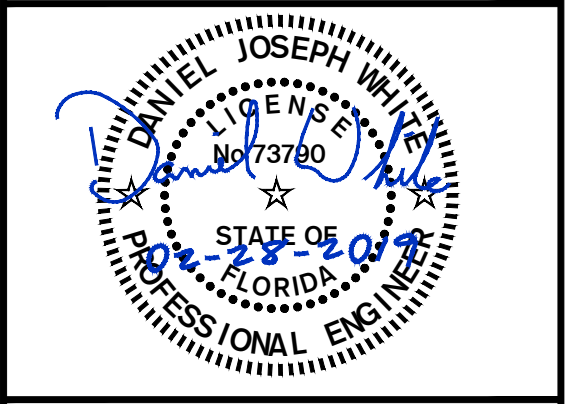

Revision

Date	No.	Description

Drawn By: SD/DS
 Checked By: DJW

Date: 01-01-19

Project No.: 17057.5

Drawing Title:
**ELECTRICAL
 LEGEND & NOTES**

Drawing No.: E100

Number: Garck Consulting Engineers
 142 Eglon Parkway SE
 Fort Walton Beach, Florida 32548
 Email: admin@gsce.com
 Ph: 850.263.6750 Fax: 850.964.5420
 FL Authorization No. 00006680

Christopher A. Garcia, FL PE No. 73172
 Thomas A. Alexander, FL PE No. 73172
 Daniel J. White, FL PE No. 73190



DAG ARCHITECTS INC.
1223 AIRPORT ROAD DESTIN, FLORIDA 32541
TELEPHONE: 850-837-8152
A-S-CIB0745

OWNERSHIP OF INSTRUMENTS OF SERVICE
ALL REPORTS, PLANS, SPECIFICATIONS, COMPUTER FILES, FIELD DATA, NOTES AND OTHER DOCUMENTS AND INSTRUMENTS PREPARED BY THE CONSULTANT AS INSTRUMENTS OF SERVICE SHALL REMAIN THE PROPERTY OF THE CONSULTANT. THE CONSULTANT SHALL RETAIN ALL COMMON LAW, STATUTORY AND OTHER RESERVED RIGHTS, INCLUDING THE COPYRIGHT THERE TO.

BID DOCUMENTS

EMERALD COAST CONVENTION CENTER
RESTROOM RENOVATIONS & MEETING ROOM COUNTERS

TASK ORDER NO. 5 - C18-2638-TDD
1250 MIRACLE STRIP PKWY SE
FORT WALTON BEACH, FL 32548

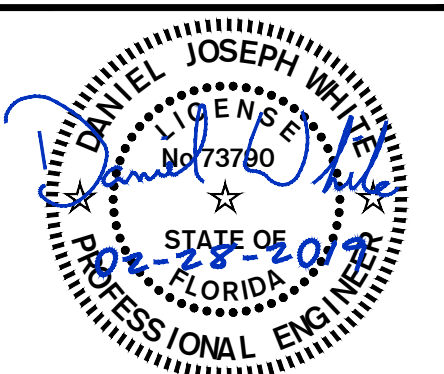

Revision

Date	No.	Description

Drawn By: SD/DS
Checked By: DJW

Date: 01-01-19

Project No.: 17057.5

Drawing Title:
PARTIAL PLAN -
ELECTRICAL NEW
WORK - MEETING
ROOMS

Drawn No.: E-300



- NOTES:
- CONNECT TO ADJACENT RECEPTACLE CIRCUIT.
 - INSTALL NEW RECESSED QUAD RECEPTACLE. MOUNT CENTER LINE 4" ABOVE TOP OF BACKSPASH. CONNECT TO EXISTING RECEPTACLE CIRCUIT CURRENTLY SERVING THIS AREA.
 - REMOVE EXISTING PANEL PA AND INSTALL NEW. REFER TO PANEL SCHEDULE.

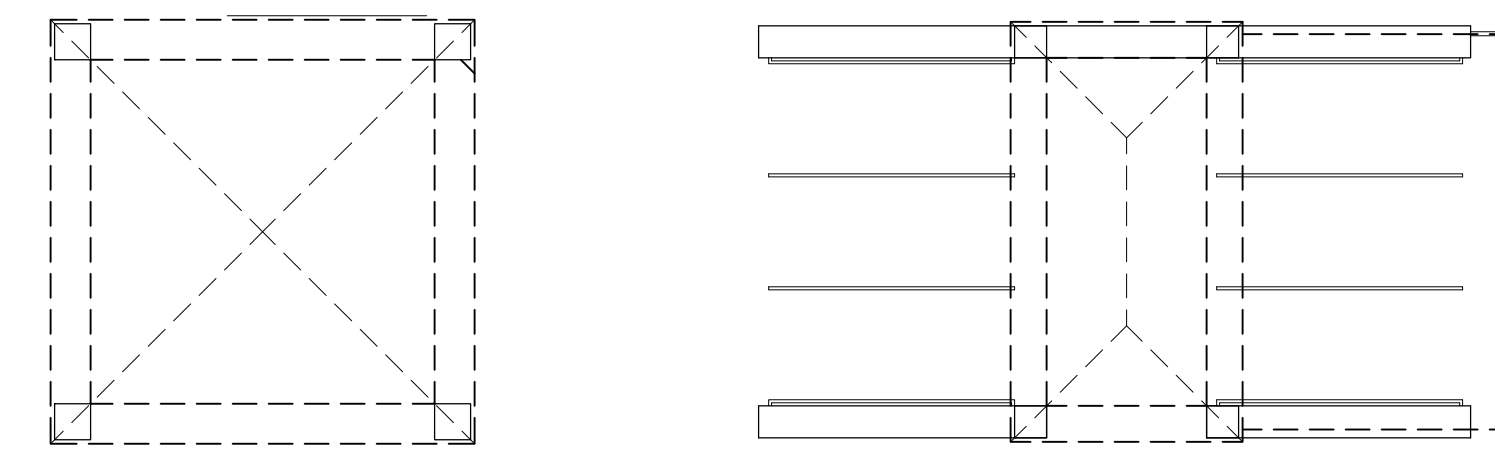

PARTIAL PLAN - ELECTRICAL NEW WORK - MEETING ROOMS
1/8" = 1'-0"

Number-Garick Consulting Engineers
167 Egan Parkway SE
Fort Walton Beach, Florida, 32548
Email: admin@n-gce.com
Ph: 850.243.8723 Fax: 850.864.5420
FL Authorization No. 00006980

Christopher A. Garick, FL PE No. 53924
Thomas A. Alexander, FL PE No. 73172
Daniel J. White, FL PE No. 72760

1835
Job No.



DAG ARCHITECTS INC.
1223 AIRPORT ROAD DESTIN, FLORIDA 32541
TELEPHONE: 850-837-8152
AA-C0007-25

OWNERSHIP OF INSTRUMENTS OF SERVICE
ALL REPORTS, PLANS, SPECIFICATIONS, COMPUTER FILES, FIELD DATA, NOTES AND OTHER DOCUMENTS AND INSTRUMENTS PREPARED BY THE CONSULTANT AS INSTRUMENTS OF SERVICE SHALL REMAIN THE PROPERTY OF THE CONSULTANT. THE CONSULTANT SHALL RETAIN ALL COMMON LAW, STATUTORY AND OTHER RESERVED RIGHTS, INCLUDING THE COPYRIGHT THEREIN.

BID DOCUMENTS

EMERALD COAST CONVENTION CENTER
RESTROOM RENOVATIONS & MEETING ROOM
COUNTERS

TASK ORDER NO. 5 - C18-2638-TDD
1250 MIRACLE STRIP PKWY SE
FORT WALTON BEACH, FL 32548

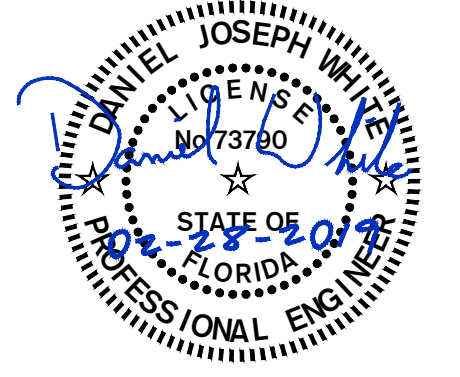

Revision		
Date	No.	Description

Drawn By: SD/DS
Checked By: DJW

Date: 01-01-19

Project No.: 17057.5

Drawing Title:
ELECTRICAL DEMOLITION - RESTROOMS

Drawing No.: ED-200

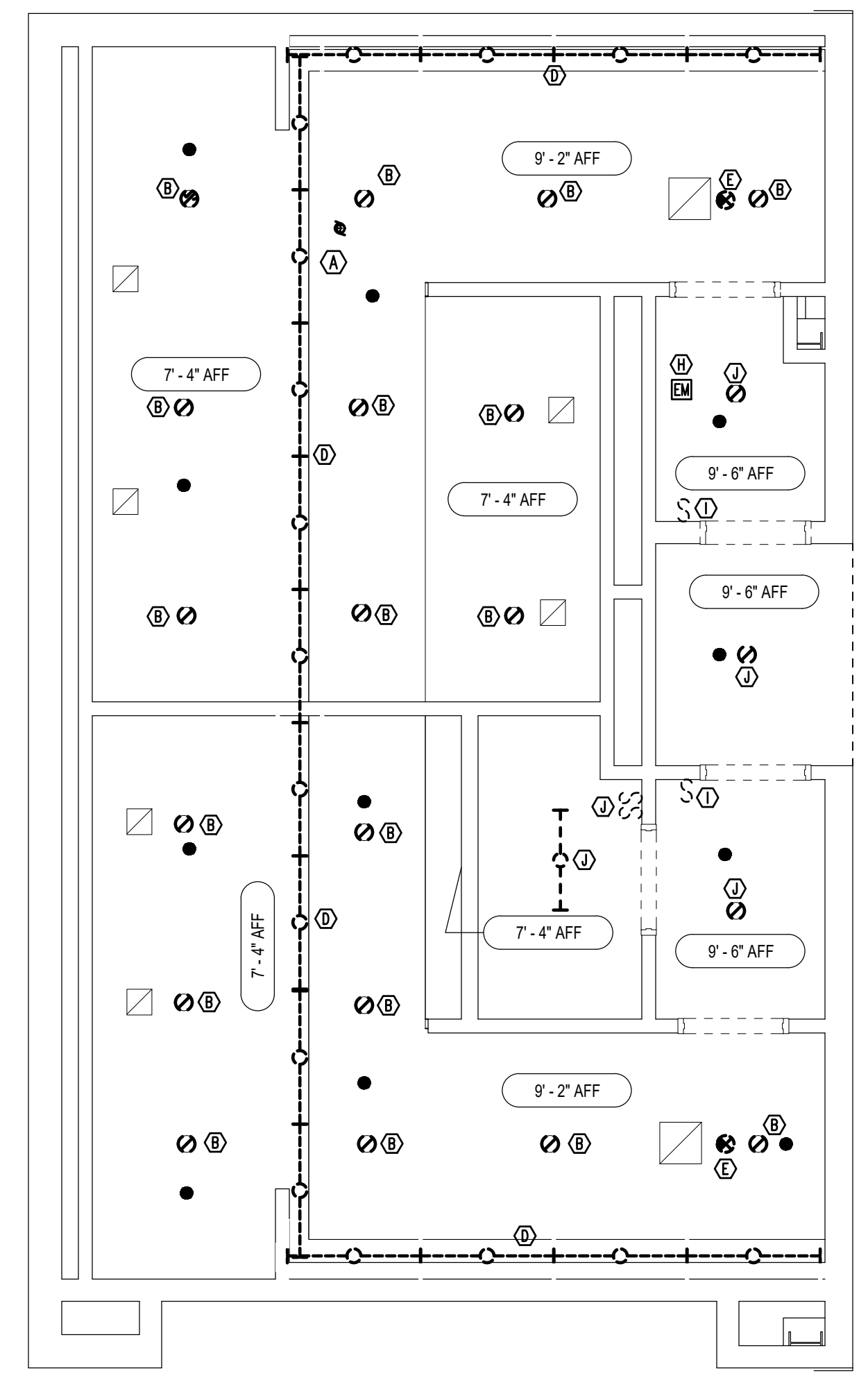

**ELECTRICAL LIGHTING DEMOLITION
RESTROOMS #1 & #2**
SCALE: 1/4" = 1' - 0"

- ELECTRICAL DEMOLITION NOTES:**
- ① IF REQUIRED DISCONNECT AND RECONNECT EXISTING EXHAUST FAN TO REMAIN. MAINTAIN EXISTING CIRCUIT, VERIFY.
 - ② DISCONNECT AND REMOVE EXISTING RECESSED CAN LIGHT. INSTALL NEW RECESSED CAN LIGHT AND RECONNECT EXISTING CIRCUIT TO NEW RECESSED CAN LIGHT. EXTEND AND/OR MAINTAIN EXISTING CIRCUIT CONTINUITY AS REQUIRED FOR NEW FIXTURE INSTALLATION.
 - ③ DISCONNECT AND REMOVE EXISTING CEILING MOUNTED LIGHT FIXTURE. INSTALL NEW FIXTURE AND RECONNECT EXISTING CIRCUIT, MAINTAIN CIRCUIT CONTINUITY, VERIFY.
 - ④ DISCONNECT AND REMOVE ALL COVE LIGHTS. REMOVE CONDUCTORS BACK TO NEXT ACTIVE LIGHT.
 - ⑤ DISCONNECT AND REMOVE EXISTING EXIT LIGHT. INSTALL NEW EXIT LIGHT AND RECONNECT TO EXISTING CIRCUIT. MAINTAIN CIRCUIT CONTINUITY.
 - ⑥ REMOVE EXISTING SWITCH AND COVERPLATE. REPLACE WITH NEW SWITCH AND COVERPLATE.
 - ⑦ REMOVE EXISTING LINE VOLTAGE SWITCH AND COVERPLATE. REPLACE WITH NEW LOW VOLTAGE SWITCH AND COVERPLATE. REFER TO LIGHTING CONTROLS DETAILS FOR CONNECTION REQUIREMENTS.
 - ⑧ REMOVE EXISTING EMERGENCY LIGHTING RELAY. PREPARE FOR CONNECTION TO NEW EMERGENCY LIGHTING RELAY. REFER TO LIGHTING CONTROLS DETAILS FOR CONNECTION REQUIREMENTS.
 - ⑨ EXISTING SWITCH TO BE REMOVED. REMOVE EXISTING CONDUCTORS BACK TO SOURCE AND INSTALL FINISHED BLANK COVERPLATE.
 - ⑩ EXISTING DEVICE TO REMAIN.

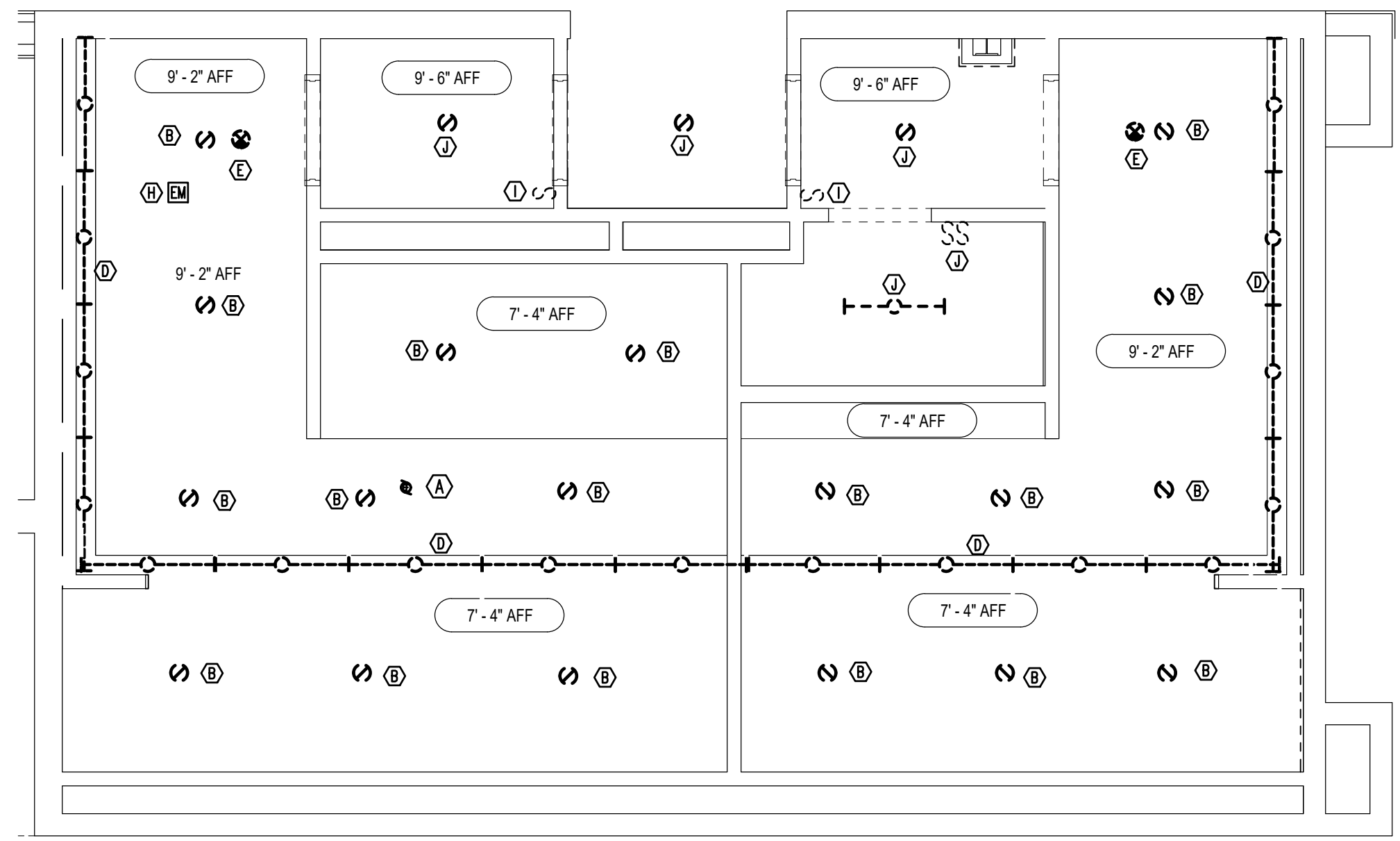

**ELECTRICAL LIGHTING DEMOLITION
RESTROOMS #3 & #4**
SCALE: 1/4" = 1' - 0"

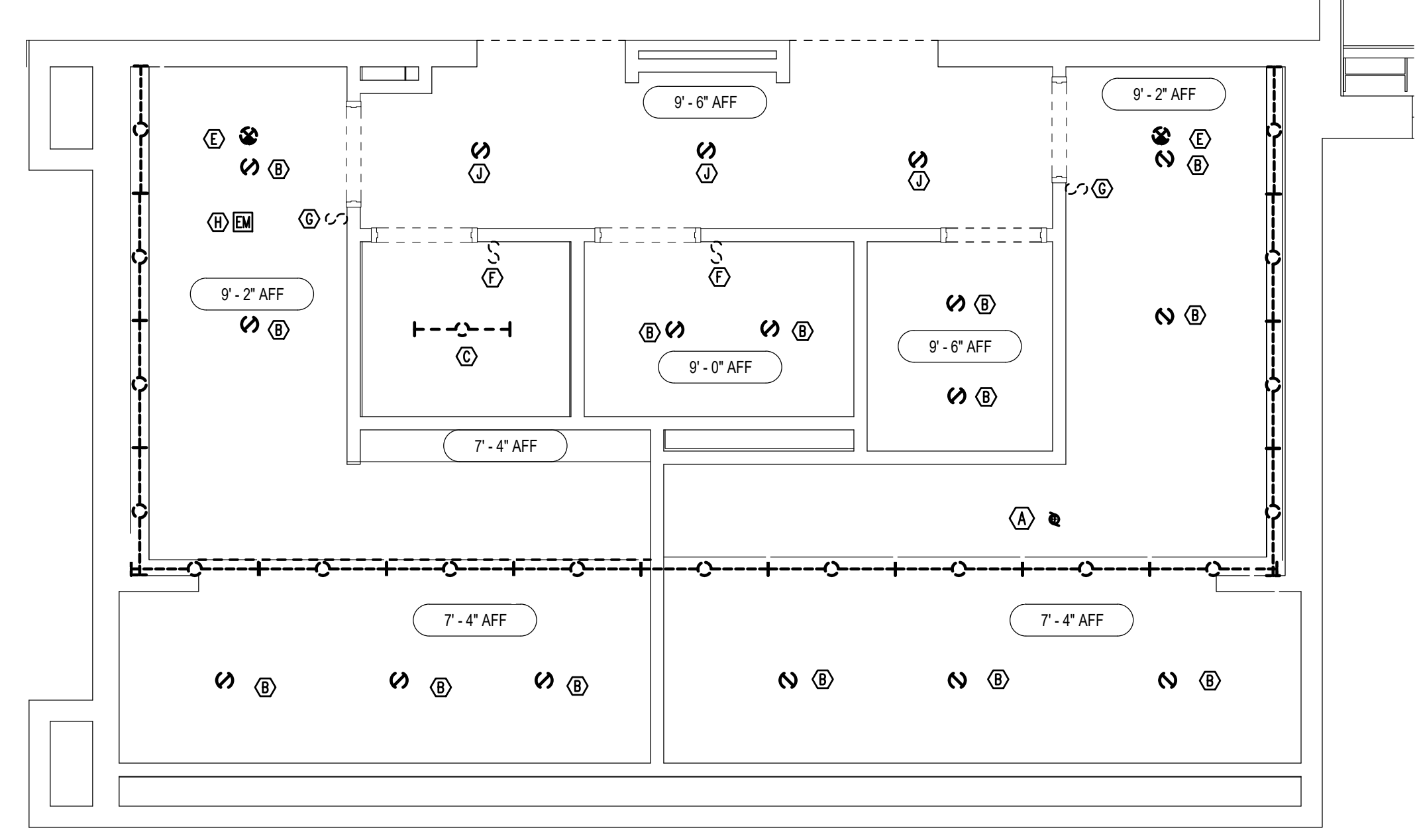

**ELECTRICAL LIGHTING DEMOLITION
RESTROOMS #5 & #6**
SCALE: 1/4" = 1' - 0"

ELECTRICAL DEMOLITION - RESTROOMS
1/4" = 1'-0"

ENGINEERS
Humber/Garick Consulting Engineers
142 Edlin Parkway SE
Fort Walton Beach, Florida, 32548
Email: senn@humbergarick.com
Ph: 850.243.0723 Fax: 850.864.5420
FL Authorization No. 00000000

Christopher A. Garick, FL PE No. 57994
Thomas A. Alexander, FL PE No. 73172
Doreen J. White, FL PE No. 73795

1835
Job No.